



University of Miami Building Standards (UMBS)

INTRODUCTION

The principal purposes of these Building Standards are to ensure that the University's buildings, grounds and infrastructure, be of a quality control standard consistent with the best practices for higher education, to implement the University's commitment to sustainability, and to ensure the life cycle value of the physical campus environment.

The standards have been developed as a practical tool for the planning, design, construction and maintenance of facilities. The content is organized in the format of the Construction Specifications Institute (CSI), the design and construction industry standard, to support professionals in their development of construction documents, bidding and procurement of materials. The standards are available via the internet.

The Building Standards are administered by the University of Miami Building Standards Committee (UMBSC), under the jurisdiction of the Office of the University Architect and UM Facilities Management. This committee meets monthly to take under advisement new regulatory and industry developments, as well as requests for clarifications or exceptions. The committee releases updates of the standards at the end of each calendar year.

The UMBS promote consistency and excellence across all University facilities, and support LEED Silver certification as a minimum in all new buildings and renovations.

TABLE OF CONTENTS

INTRODUCTION

00 01 01 Building Standards-University of Miami Table of Contents

DIVISION 00 – PROCUREMENT AND CONTRACTING

Future Expansion- (TBD)

DIVISION 01 – GENERAL REQUIREMENTS

Future Expansion- (TBD)

DIVISION 02 – EXISTING CONDITIONS

Future Expansion- (TBD)

DIVISION 03 – CONCRETE

- 3.1 General Requirements
 - 3.2 Codes and Standards
 - 3.3 Design Criteria
 - 3.4 Specific Concrete Requirements
-
- 03 30 00 Cast-In-Place Concrete
 - 03 33 00 Architectural Concrete
 - 03 38 16 Un-bonded Post-Tensioned Concrete

DIVISION 04 – MASONRY

- 4.1 General Requirements
 - 4.2 Codes and Standards
 - 4.3 Design Criteria
 - 4.4 Specific Masonry Requirements
-
- 04 22 00 Concrete Unit Masonry

DIVISION 05 – METALS

- 5.1 General Requirements
- 5.2 Codes and Standards
- 5.3 Design Criteria
- 5.4 Specific Metals Requirements

05 12 00	Structural Steel Framing
05 21 00	Steel Joist Framing
05 31 00	Steel Decking
05 40 00	Cold-Formed Metal Framing
05 44 00	Cold Formed Metal Trusses
05 50 00	Metal Fabrications

DIVISION 06 – WOOD AND PLASTICS

6.1	General Requirements
6.2	Codes and Standards
6.3	Design Criteria
6.4	Specific Requirements
06 10 00	Rough Carpentry
06 40 23	Interior Architectural Woodwork

DIVISION 07 – THERMAL AND MOISTURE PROTECTION

7.1	General Requirements
7.2	Codes and Standards
7.3	Design Criteria
7.4	Specific Requirements
07 01 50.19	Preparation for Replacement/Re-roofing
07 10 00	Dampproofing and Waterproofing
07 18 00	Traffic Coatings
07 21 00	Thermal Insulation
07 52 00	Roofing
07 52 13	Roofing
07 54 16	Roofing
07 54 19	Roofing
07 60 11	Flashing and Sheet Metal
07 70 00	Roof Specialties, Accessories and Skylights
07 81 00	Applied Fireproofing
07 92 00	Joint Sealants
07 95 00	Expansion Control

DIVISION 08 – OPENINGS

8.1	General Requirements
8.2	Codes and Standards
8.3	Design Criteria
8.4	Specific Requirements
08 10 00	Doors and Frames
08 11 13	Hollow Metal Doors and Frames
08 14 16	Flush Wood Doors

08 41 13	Aluminum-Framed Entrances, Storefronts and Glazed Aluminum Curtain Walls
08 41 26	All Glass Entrances and Storefronts
08 51 13	Aluminum Windows
08 71 00	Door Hardware
08 80 00	Glazing
08 83 00	Mirrors
08 91 19	Wall Louvers

APPENDIX "A" Master Door Hardware

APPENDIX "B" Door Hardware Card Access Diagrams

DIVISION 09 – FINISHES

9.1	General Requirements
9.2	Codes and Standards
9.3	Design Criteria
9.4	Specific Requirements
09 22 16	Non-Structural Metal Framing
09 24 00	Portland Cement Plastering
09 26 13	Gypsum Veneer Plastering
09 27 13	Glass-Fiber-Reinforced Plaster Fabrications
09 29 00	Gypsum Board
09 30 00	Tiling
09 30 33	Stone Tiling
09 51 23	Acoustical Panel Ceiling
09 54 23	Linear Metal Ceilings
09 54 36	Suspended Decorative Grids
09 54 43	Stretched-Fabric Ceiling Systems
09 54 46	Fabric Wrapped Ceiling Panels
09 63 40	Stone Flooring
09 64 00	Wood Flooring
09 64 66	Wood Athletic Flooring
09 65 00	Resilient Flooring, Base and Accessories
09 65 66	Resilient Athletic Flooring
09 66 23	Resinous Matrix Terrazzo Flooring
09 67 23	Resinous Flooring
09 68 00	Sheet Carpeting and Carpet Tiles
09 69 00	Access Flooring
09 72 00	Wall Coverings
09 75 13	Stone Wall Facing
09 75 16	Stone Base
09 75 19	Stone Trim
09 75 23	Stone Window Stools
09 77 13	Stretched-Fabric Wall Systems
09 77 23	Fabric-Wrapped Panels
09 84 33	Sound-Absorbing Wall Units

09 84 36	Sound-Absorbing Ceiling Units
09 91 00	Interior and Exterior Painting
09 93 00	Staining and Transparent Finishes
09 94 19	Multicolor Interior Finishing
09 96 00	High-Performance Coatings
09 96 33	High-Temperature-Resistant Coatings
09 96 53	Elastomeric Coatings
09 97 26	Cementitious Coatings

DIVISION 10 – SPECIALTIES

10.1	General Requirements
10.2	Codes
10.3	Standards
10.4	Design Criteria
10.5	Specific Requirements
10 11 00	Visual Display Surfaces
10 12 00	Display Cases
10 13 00	Directories
10 14 16	Plaques
10 14 19	Dimensional Letter Signage
10 17 00	Telephone Specialties
10 21 13	Toilet Compartments
10 21 16	Shower and Dressing Compartment
10 21 23	Cubicles
10 22 13	Wire Mesh Doors and Partitions
10 22 19	Demountable Partitions
10 22 39	Folding Panel Partitions
10 26 00	Wall and Door Protection
10 28 00	Toilet Room Accessories
10 43 00	Emergency Aid Specialties
10 44 13	Fire Protection Cabinets
10 44 16	Fire Extinguishers
10 51 13	Metal Lockers
10 55 00 13	USPS Delivery Postal Specialties
10 55 00 16	Private Delivery Postal Specialties
10 56 13	Metal Storage Shelving
10 56 26	Mobile Storage Shelving
10 73 13	Awnings
10 75 00	Flagpoles
10 83 16	Banners

DIVISION 11 – EQUIPMENT

11.1	General Requirements
11.2	Codes
11.3	Standards
11.4	Design Criteria
11.5	Specific Requirements

11 05 13	Common Motor Requirements for Equipment
11 12 00	Parking Control Equipment
11 13 00	Loading Dock Equipment
11 31 00	Residential Appliances
11 40 00	Food Service Equipment
11 51 23	Library Stack Equipment
11 52 13	Projection Screens
11 53 13	Laboratory Fume Hoods
11 61 43	Stage Curtains
11 66 23	Gymnasium Equipment
11 66 53	Gymnasium Dividers
11 82 26	Facility Waste Compactors

DIVISION 12 – FURNISHINGS

12.1	General Requirements
12.2	Codes
12.3	Standards
12.4	Design Criteria
12.5	Specific Requirements
12 21 13	Horizontal Louver Blinds
12 24 13	Roller Window Shades
12 36 40	Stone Countertops
12 36 61	Simulated Stone Countertops
12 48 16	Entrance Floor Grilles
12 61 00	Fixed Audience Seating
12 93 00	Site Furnishings

DIVISION 13 – SPECIAL CONSTRUCTION

13.1	General Requirements
13.2	Codes and Standards
13.3	Design Criteria
13.5	Specific Requirements
13 24 16	Saunas
13 27 00	Vaults

DIVISION 14 – CONVEYING SYSTEMS

14.1	General Requirements
14.2	Codes
14.3	Standards
14.4	Design Criteria
14.5	Specific Requirements

- 14 10 00 Dumbwaiter
- 14 21 00 Electric Traction Elevators
- 14 21 13 Electric Traction Freight Elevators
- 14 24 00 Hydraulic Elevators
- 14 24 13 Hydraulic Freight Elevators
- 14 41 19 Stairway Chairlifts
- 14 42 00 Wheelchair Lifts

DIVISION 21 – FIRE SUPPRESSION

- 21.1 General Requirements
- 21.2 Codes
- 21.3 Standards
- 21.4 Fire Suppression Design Criteria
- 21.5 Specific Fire Suppression Requirements

- 21 11 00 Facility Fire-Suppression Water-Service Piping
- 21 12 00 Fire Suppression Standpipes
- 21 13 13 Wet-Pipe Sprinkler Systems
- 21 22 00 Clean-Agent Fire Extinguishing Systems
- 21 31 13 Electric-Drive Centrifugal Fire Pumps
- 21 34 00 Pressure-Maintenance Pumps
- 21 39 00 Controllers for Fire Pumps Drivers

DIVISION 22SW – PLUMBING (Site Work)

- 22.1 General Requirements
- 22.2 Codes and Standards
- 22.3 Design Criteria
- 22.4 Specific Plumbing (Site Work) Requirements

- 22 11 13 Facility Water Distribution Piping
- 22 13 13 Facility Water Sewers

DIVISION 22 - PLUMBING

- 22.1 General Requirements
- 22.2 Codes and Standards
- 22.3 Plumbing and Design Criteria
- 22.5 Utility Coordination
- 22.6 Mechanical Rooms (for plumbing equipment)
- 22.6 Specific Plumbing Requirements
- 22 05 16 Expansion Fittings and Loops for Plumbing Piping
- 22 05 17 Sleeves and Sleeves Seals for Plumbing Piping
- 22 05 19 Meters and Gages for Plumbing Piping
- 22 05 23 General Duty Valves for Plumbing Piping
- 22 05 29 Hangers and Supports for Plumbing Piping and Equipment

22 05 53 Identification for Plumbing Piping and Equipment
 22 07 16 Plumbing Equipment Insulation
 22 07 19 Plumbing Piping Insulation
 22 11 16 Domestic Water Piping
 22 11 23 Domestic Water Pumps
 22 13 16 Sanitary Waste and Vent Piping
 22 13 23 Sanitary Waste Interceptors
 22 14 29 Sump Pumps
 22 15 13 General Service Compressed Air Piping
 22 15 19 General Service Packaged Air Compressors and Receivers
 22 33 00 Electric Domestic Water Heaters
 22 34 00 Fuel Fired Domestic Water Heaters
 22 40 00 Plumbing Fixtures
 22 45 00 Emergency Plumbing Fixtures
 22 47 13 Drinking Fountains and Remote Water Coolers

DIVISION 23 – HEATING, VENTILATING, AND AIR CONDITIONING

23.1 General Requirements
 23.2 Codes and Standards
 23.3 Heating, Ventilation and Air Conditioning Design Criteria
 23.4 Utility Coordination

23.5 Distribution System
 23.6 Mechanical Rooms
 23.7 Specific Requirements

23 05 14 Wiring, Motors, Starters and Variable Frequency Drives for HVAC Equipment
 23 05 16 Expansion Fittings and Loops for HVAC Piping
 23 05 19 Meters and Gages for HVAC Piping
 23 05 23 General-Duty Valves for HVAC Piping
 23 05 29 Hangers and Supports for HVAC Piping and Equipment
 23 05 48 Vibration and Seismic Controls for HVAC Piping and Equipment
 23 05 53 Identification for HVAC Piping and Equipment
 23 05 93 Testing, Adjusting, and Balancing for HVAC
 23 07 00 HVAC Insulation
 23 08 00 Commissioning of HVAC
 23 09 00 Instrumentation and Control for HVAC
 23 09 93 Sequence of Operations for HVAC Controls
 23 11 13 Facility Fuel-Oil Piping
 23 11 23 Facility Natural-Gas Piping

23 11 26 Facility Liquefied-Petroleum Gas Piping
 23 21 13 Hydronic Piping
 23 21 23 Hydronic Pumps
 23 23 00 Refrigerant Piping
 23 25 00 HVAC Water Treatment
 23 31 13 Metal Ducts
 23 31 19 HVAC Casings

23 33 00	Air Duct Accessories
23 34 23	HVAC Power Ventilators
23 36 00	Air Terminal Units
23 37 13	Diffusers, Registers, and Grilles
23 37 23	HVAC Gravity Ventilators
23 41 00	Particulate Air Filtration
23 41 33	High-Efficiency Particulate Filtration
23 57 00	Heat Exchangers for HVAC
23 64 16	Centrifugal Water Chillers
23 64 23	Scroll-Water Chiller
23 64 26	Rotary-Screw Water Chillers
23 64 27	Magnetic Bearing Chillers
23 65 00	Cooling Towers
23 72 00	Air-to-Air Energy Recovery Equipment
23 73 13	Modular Central-Station Air-Handling Units
23 74 13	Packaged, Outdoor, Central-Station Air Handling Units
23 74 33	Packaged, Outdoor or Rooftop Air-Conditioners
23 81 13	Packaged Terminal Air-Conditioners
23 81 23	Computer-Room Air Conditioners
23 81 26	Split-System Air-Conditioners
23 82 16	Air Coils
23 82 19	Fan Coil Units

DIVISION 25 – INTEGRATED AUTOMATION

25.1	General Requirements
25.2	Specific Requirements - Products
25.3	Execution

DIVISION 26 – ELECTRICAL

26.1	General Requirements
26.2	Codes and Standards
26.3	Design Criteria
26.4	Utility Coordination
26.5	Distribution System
26.6	Electrical Rooms
26.7	Specific Electric Requirements
26 05 13	Medium-Voltage Cables
26 05 19	Low-Voltage Electrical Power Conductors and Cables
26 05 23	Control-Voltage Electrical Power Cables
26 05 26	Grounding and Bonding for Electrical Systems
26 05 29	Hangers and Supports for Electrical Systems
26 05 33	Raceways and Boxes for Electrical Systems
26 05 36	Cable Trays for Electrical Systems
26 05 39	Underfloor Raceways for Electrical Systems
26 05 43	Underground Ducts and Raceways for Electrical Systems

26 05 44	Sleeves and Sleeve Seals for Electrical Raceways and Cabling
26 05 48	Vibration and Seismic Controls for Electrical Systems
26 05 53	Identification for Electrical Systems
26 05 73	Overcurrent Protective Device Coordination Study
26 09 13	Electrical Power Monitoring and Control
26 11 16	Secondary Unit Substations
26 12 00	Medium Voltage Transformers
12 13 00	Medium Voltage Switchgear
26 22 00	Low-Voltage Transformers
26 23 00	Low-Voltage Switchgear
26 23 13	Paralleling Low-Voltage Switchgear
26 24 13	Switchboards
26 24 16	Panelboards
26 24 16.16	Electronically Operated Circuit-Breaker Panelboards
26 24 19	Motor-Control Centers
26 25 00	Enclosed Bus Assemblies
26 26 00	Power Distribution Units
26 27 13	Electricity Metering
26 27 26	Wiring Devices
26 28 13	Fuses
26 28 16	Enclosed Switches and Circuit Breakers
26 29 13	Enclosed Controllers
26 29 23	Variable-Frequency Motor Controllers
26 31 00	Photovoltaic Energy Equipment
26 32 13	Engine Generators
26 33 23	Central Battery Equipment
26 33 53	Static Uninterruptable Power Supply
26 36 00	Transfer Switches
26 41 13	Lightning Protection for Structures
26 42 00	Cathodic Protection
26 43 13	Surge Protection for Low-Voltage Electrical Power Circuits
26 51 00	Interior Lighting
26 55 61	Theatrical Lighting
26 56 00	Exterior Lighting
26 56 68	Exterior Athletic Lighting

DIVISION 27 – COMMUNICATIONS

27.1	General Requirements
27.2	Performance Requirements
27.3	Codes and Standards
27.4	Telecommunication Networking Standard
27.5	Telecommunication Wiring Standard-Conduit Systems
27.6	Telecommunication Wiring Standard-Cabling and Wire
27.7	Telecommunication Wiring Standard-Firestopping
27.8	Design Criteria
27.9	Specific Requirements

27 05 28	Interior Communication Pathways
27 05 43	Exterior Communication Pathways
27 08 00	Testing, Identification and Administration
27 11 00	Telecommunication Rooms
27 11 13	Equipment Rooms and Services Entrances
27 13 00	Communications Backbone Cabling
27 15 00	Communications Horizontal Cabling

DIVISION 28 – ELECTRONIC SAFETY AND SECURITY

28.1	General Requirements
28.2	Codes and Standards
28.3	Design Criteria
28.4	Specific Requirements
28 16 00	Intrusion Detection and Access Control
28 23 00	Video Surveillance
28 31 11	Digital Addressable Fire Alarm System
28 35 00	Refrigerant Detection and Alarm

DIVISION 31 – EARTHWORK

31.1	General Requirements
31.2	Codes and Standards
31.3	Design Criteria
31.4	Specific Earthwork Requirements
31 10 00	Site Clearing
31 20 00	Earth Moving
31 23 19	Dewatering
31 31 16	Termite Control
31 50 00	Excavation Support and Protection
31 62 13	Concrete Piles

DIVISION 32 – EXTERIOR IMPROVEMENTS

32.1	General Requirements
32.2	Codes and Standards
32.3	Design Criteria
32.4	Specific Exterior Improvements Requirements
32.12.16	Asphalt Paving
32.13.13	Concrete Paving
32.13.16	Decorative Concrete Paving
32 13 73	Concrete Paving Joint Sealants
32 14 00	Unit Paving
32 14 43	Permeable Unit Paving
32 17 13	Parking Bumpers

32 17 23	Pavement Markings
32 17 29	Manufactured Traffic Calming Devices
32 31 13	Chain-Link Fences and Gates
32 31 19	Decorative Fences and Gates
32 84 00	Planting Irrigation
32 91 00	Planting Topsoil
32 92 00	Transplanting
32 97 00	Landscape Stone and Gravel

DIVISION 33 – UTILITIES

33.1	General Requirements
33.2	Codes and Standards
33.3	Design Criteria
33.4	Specific Utilities Requirements
33 21 00	Water Supply Wells for Irrigation
33 41 00	Storm Utility Drainage Piping
33 46 00	Sub-drainage

DIVISION 03 CONCRETE

This chapter identifies criteria for concrete design in University of Miami (UM) buildings and site structures with the purpose of establishing minimum standards, acceptable to UM, to be used as the basis of design for UM Coral Gables Campus.

- 03.1 General Requirements
 - 03.1.1 Submittals
- 03.2 Codes and Standards
 - 03.2.1 Cast-in-Place Concrete, Architectural Concrete, and Unbonded Post-Tensioned Concrete
- 03.3 Design Criteria
 - 03.3.1 Cast-in-Place Concrete, Architectural Concrete, and Unbonded Post-Tensioned Concrete
- 03.4 Specific Concrete Requirements (organized by CSI Master Format® 2012 Numbers & Titles)

03.1 General Requirements

All work shall be designed by a Professional Structural Engineer licensed in the State of Florida.

Before the start of construction on new buildings and/or major renovations, the Contractor shall provide a drawing for each building floor level showing the coordination of all structural, architectural and MEP items. This includes, but is not limited to: Structural members, floor plates, architectural ceilings, soffits, smoke barriers, fire walls, vertical shafts, sleeves, fire dampers, HVAC ductwork and equipment, plumbing piping and equipment, fire protection piping and equipment, alarm systems, communications, electrical distribution and equipment, lighting, controls, BMS, lighting protection, security systems, etc.

The following information shall be obtained from the UM Project Manager:

1. Geotechnical investigation reports

UM Coral Gables Campus and UM Buildings concrete design must comply with the following objectives:

1. Sustainable Design.
2. Flexibility to allow for major and minor alterations which will occur during the typical building's life span, without causing major disruptions to other areas of the building.
3. High level of integration between architecture and the engineering systems using the latest advancements in technology.
4. Solutions with the best value considering a life cycle cost analysis to account for the total project cost.

The design of concrete buildings and structures, in concert with other building components, shall produce a building that meets the programmed sustainability rating (LEED rating) of the specific project.

03.1.1 Submittals

The Design Professional must ensure that all submittals and shop drawings are coordinated with other disciplines.

03.2 Codes and Standards

The Concrete design for Cast-in-Place Concrete, Architectural Concrete, and Un-bonded Post-tensioned concrete, shall comply with the requirements of the applicable authorities having jurisdiction, and with the in-force edition at the time of the project of the following codes and standards:

1. American Society of Testing and Materials (ASTM)
2. American Concrete Institute (ACI)
3. National Ready Mixed Concrete Association (NRMCA)
4. United States Corps of Engineers (CE)
5. Concrete Reinforcing Steel Institute (CRSI)
6. Post-Tensioning Institute (PTI)
7. American Association of State Highway and Transportation Officials (AASHTO)
8. American Architectural Manufacturers Association (AAMA)

03.3 Design Criteria

03.3.1 Cast-in-Place Concrete, Architectural Concrete, and Un-bonded Post-Tensioned Concrete

1. Cast-in place concrete design shall include the following:
 - a. The design of the subgrade including compaction (specify minimum thickness).
 - b. The concrete design is to be coordinated with architecture and other disciplines as to enhance the building's program and blending with existing UM college atmosphere.
 - c. Cast-in-place concrete structures are to include:
 - (1) Concrete slabs on grade.
 - (2) Structural slabs.
 - (3) Columns, concrete walls, shear walls, retaining walls and foundations.
 - d. Refer to the "Durability Requirements", Chapter of ACI318. Comply with the water/cement ratios indicated in the table: "Requirements for Special Exposure Conditions".
2. Architectural concrete design shall include the following:
 - a. The design of the subgrade including compaction and stabilization, where required by soil conditions (specify minimum thickness).
 - b. The design of exposed concrete structures. Coordinate finishes with architecture.
 - c. Architectural concrete structures may also include:

- (1) Exposed concrete columns, concrete walls and shear walls.
 - (2) Exposed concrete retaining walls.
3. Un-bonded post-tensioned concrete design shall include the following:
- a. The design and specification of concrete slabs to achieve the following:
 - (1) Thinner concrete slabs.
 - (2) Reduction in the amount of reinforcing.

03.4 Specific requirements (organized by CSI MasterFormat® 2012 Numbers & Titles)

03 30 00	Cast-in-Place Concrete
03 33 00	Architectural Concrete
03 38 16	Un-bonded Post-Tensioned Concrete

03 30 00 Cast-In-Place Concrete

Design Standards

1. The design of cast-in place concrete is to include the following:
 - a. LEED submittals:
 - (1) Product data for Credit MR 4.
 - (2) Product data for Credit IEQ 4.3
 - (3) Design mixture for Credit ID 1.1
 - b. Cast-in-place materials:
 - (1) Steel reinforcement
 - (a) Recycled content of steel products:
 - (1.) Post-consumer recycled content, plus one-half of pre-consumer recycled content not less than 25 percent.
 - (b) Reinforcing Bars: ASTM A615, Grade 60, deformed. The use of uncoated bars are generally acceptable, except in cases where the building may be exposed to aggressive environments, such as ocean fronts, maritime structures, etc. , and areas where the bars would be exposed to a high level of corrosion. Where these conditions occur, the following guidelines will apply:
 - (1.) Galvanized reinforcing bars zinc coated after fabrication and bending as per ASTM A767, where required.
 - (2.) Epoxy-coated reinforcing bars epoxy coated, with less than 2 percent damaged coating in each 12-inch bar length as per ASTM A775, where required.
 - (c) Plain-steel welded wire reinforcement is to be fabricated from as-drawn steel wire into flat sheets, as per ASTM A185 (where required).
 - (d) Deformed-Steel Welded Wire Reinforcement, flat sheet as per ASTM A497, where required.
 - (e) Galvanized-steel welded wire reinforcement is to be fabricated from galvanized-steel wire into flat sheets as per ASTM A185, where required.

- (f) Epoxy-coated welded wire reinforcement is to be Class A coated, Type 1, plain or deformed steel, as per ASTM A884, where required.
 - (g) Bar Supports: Bolsters, chairs, spacers, and other devices for spacing, supporting, and fastening reinforcing bars and welded wire reinforcement in place. Manufacture bar supports from steel wire, plastic, or precast concrete according to CRSI's "Manual of Standard Practice.
- (2) Concrete materials:
- (a) Cementitious Material: Use the same cementitious materials, of the same type, brand, and source, throughout the entire project.
 - (b) Portland cement: ASTM C150 gray or white. Supplement, where required with the following:
 - (1.) Fly Ash: ASTM C618, Class F or C.
 - (2.) Ground granulated blast-furnace slag: ASTM C989, Grade 100 or 120.
 - (c) Blended hydraulic cement: ASTM C595, Type IS, Portland blast-furnace slag, Type IP, Portland-pozzolan, Type I (PM), pozzolan-modified Portland or Type I (SM), slag-modified Portland cement, if required.
- (3) Normal-weight aggregates: ASTM C33, graded.
- (a) Maximum coarse-aggregate size as required.
 - (b) Fine Aggregate where required, shall be free of materials with deleterious reactivity to alkali in cement.
- (4) Light-weight aggregates as per ASTM C330. Specify nominal maximum aggregate size.
- (5) Water as per ASTM C94 or potable.
- (6) Admixtures (when required):
- (a) Air-entraining admixture: ASTM C260.
 - (b) Specify chemical admixtures:
 - (1.) Provide certification from the manufacturer that the admixtures specified are compatible with other admixtures specified, and that they will not contribute water-soluble chloride ions exceeding those permitted in hardened concrete. Neither the use of calcium chloride nor any admixtures containing calcium chloride will be accepted.
 - (2.) Water-Reducing Admixture: ASTM C494, Type A.
 - (3.) Retarding Admixture: ASTM C494, Type B.
 - (4.) Water-Reducing and Retarding Admixture: ASTM C494, Type D.
 - (5.) High-Range, Water-Reducing Admixture: ASTM C494, Type F.
 - (6.) High-Range, Water-Reducing and Retarding Admixture: ASTM C494, Type G.
 - (7.) Plasticizing and Retarding Admixture: ASTM C1017, Type II.
- (7) Fiber reinforcement (where required):
- (a) Synthetic Micro-Fiber: Use monofilament or fibrillated polypropylene micro-fibers, engineered and designed for use in concrete, complying with ASTM C1116 Type III.

- (8) Waterstops (where required):
- (a) Flexible Rubber Waterstops: CE CRD-C 513, with factory-installed metal eyelets, for embedding in concrete to prevent passage of fluids through joints. Factory fabricated corners, intersections, and directional changes.
 - (b) Chemically Resistant Flexible Waterstops: Thermoplastic elastomeric rubber waterstops with factory-installed metal eyelets, for embedding in concrete to prevent passage of fluids through joints; resistant to oils, solvents, and chemicals. Factory fabricated corners, intersections, and directional changes.
 - (c) Flexible PVC Waterstops: CE CRD-C 572, with factory-installed metal eyelets, for embedding in concrete to prevent passage of fluids through joints. Factory fabricated corners, intersections, and directional changes.
 - (d) Self-Expanding Butyl Strip Waterstops: Manufactured rectangular or trapezoidal strip, butyl rubber with sodium bentonite or other hydrophilic polymers, for adhesive bonding to concrete.
 - (e) Self-Expanding Rubber Strip Waterstops: Manufactured rectangular or trapezoidal strip, bentonite-free hydrophilic polymer modified chloroprene rubber, for adhesive bonding to concrete.
- (9) Vapor retarders (where required):
- (a) Sheet Vapor Retarder: ASTM E1745, Include manufacturer's recommended adhesive or pressure-sensitive tape.
 - (b) Sheet Vapor Retarder: Polyethylene sheet, ASTM D 4397, not less than 10 mils thick.
- (10) Curing materials (where required):
- (a) Evaporation Retarder: Waterborne, monomolecular film forming, manufactured for application to fresh concrete.
 - (b) Absorptive Cover: AASHTO M182, Class 2, burlap cloth made from jute or kenaf.
 - (c) Moisture-Retaining Cover: ASTM C171, polyethylene film or white burlap-polyethylene sheet.
 - (d) Water: Potable.
 - (e) Clear, Waterborne, and Membrane-Forming Curing Compound: ASTM C309, Type 1, Class B, dissipating.
 - (f) Clear, Waterborne, Membrane-Forming Curing Compound: ASTM C 309, Type 1, Class B, non-dissipating, certified by curing compound manufacturer to not interfere with bonding of floor covering.
 - (g) Clear, Solvent-Borne, Membrane Forming Curing and Sealing Compound: ASTM C1315, Type 1, Class A.
 - (1.) VOC Content: Curing and sealing compounds shall have a VOC content of 200 g/L or less when calculated according to 40 CFR 59, Subpart D (EPA Method 24).
 - (h) Clear, Waterborne, Membrane-Forming Curing and Sealing Compound: ASTM C 1315, Type 1, Class A.
 - (1.) VOC Content: Curing and sealing compounds shall have a VOC content of 200 g/L or less when calculated according to 40 CFR 59, Subpart D (EPA Method 24).
- (11) Expansion and Isolation-Joint-Filler Strips: ASTM D 1751, asphalt-saturated cellulosic fiber or ASTM D 1752, cork or self-expanding cork.

- (12) Concrete mixtures:
- (a) Prepare design mixtures for each type and strength of concrete, proportioned based on laboratory trial mixture or field test data, or both, as per ACI 301.
 - (b) Cementitious Materials: Use fly ash, pozzolan, ground granulated blast-furnace slag, and silica fume as needed to reduce the total amount of Portland cement, which would otherwise be used, by not less than 40 percent.
 - (c) Use admixtures as per the manufacturer's written instructions:
 - (1.) Use water-reducing, high-range water-reducing or plasticizing admixture in concrete, as required, for placement and workability.
 - (2.) Use water-reducing and retarding admixture when required by high temperatures, low humidity, or other adverse placement conditions.
 - (3.) Use water-reducing admixture in pumped concrete, concrete for heavy-use industrial slabs and parking structure slabs. The concrete required to be watertight, with water cementitious materials ratio below 0.50.
 - (d) Proportion normal-weight concrete mixture as follows:
 - (1.) Minimum Compressive Strength at 28 days.
 - (2.) Maximum Water-Cementitious Materials Ratio.
 - (3.) Slump limit.
 - (4.) Air content.
 - (5.) Micro-fibers where required.
 - (e) Proportion light-weight concrete mixture as follows:
 - (1.) Minimum Compressive Strength at 28 days.
 - (2.) Maximum Water-Cementitious Materials Ratio.
 - (3.) Slump limit.
 - (4.) Air content.
 - (5.) Micro-fibers if required.
 - (f) Proportion structural light-weight concrete mixture as follows:
 - (1.) Minimum Compressive Strength at 28 days.
 - (2.) Maximum Water-Cementitious Materials Ratio.
 - (3.) Slump limit.
 - (4.) Air content.
 - (5.) Micro-fibers if required.
 - (g) That the fabrication of steel reinforcing complies with the CRSI's "Manual of Standard Practice.
 - (h) Concrete mixing:
 - (1.) Ready-Mixed Concrete: Measure, batch, mix, and deliver concrete according to ASTM C94 and ASTM C 1116 and furnish batch ticket information.
 - (a.) When air temperature is between 85 and 90 deg F, reduce mixing and delivery time from 1-1/2 hours to 75 minutes; when air temperature is above 90 deg F, reduce mixing and delivery time to 60 minutes.

- c. Execution of concrete work:
- (1) Formwork:
 - (a) The contractor is to provide the design of the formwork including, erection, shoring, bracing, and maintenance as per ACI 301. The formwork is to support vertical, lateral, static, dynamic loads, and construction loads that might be applied, until the structure can support such loads.
 - (b) The formwork is to be constructed so concrete members and structures are of size, shape, alignment, elevation, and position indicated, within tolerance limits set by ACI 117.
 - (2) Installation of embedded items:
 - (a) Place and secure anchorage devices and other embedded items required for adjoining work that is attached to or supported by cast-in-place concrete. Use setting drawings, templates, diagrams, instructions, and directions furnished with items to be embedded.
 - (3) Sheet installation of vapor retarders: Place, protect, and repair sheet vapor retarder according to ASTM E 1643 and manufacturer's written instructions.
 - (a) Lap joints 6 inches and seal with manufacturers recommended tape.
 - (4) Installation of steel reinforcing:
 - (a) Comply with CRSI's "Manual of Standard Practice" for placing reinforcement.
 - (b) Do not cut or puncture vapor retarder. If damaged, repair and reseal vapor retarder before placing concrete.
 - (5) Joint installation:
 - (a) General: Construct joints true to line with faces perpendicular to surface plane of concrete.
 - (b) Construction Joints: Install so strength and appearance of concrete are not impaired, at locations indicated or as approved by the Design Professional.
 - (c) Contraction Joints in Slabs-on-Grade: Form weakened-plane contraction joints, sectioning concrete into areas as indicated. Construct contraction joints for a depth equal to at least one-fourth of concrete thickness as follows:
 - (1.) Grooved Joints: Form contraction joints after initial floating by grooving and finishing each edge of joint to a radius of 1/8 inch. Repeat grooving of contraction joints after applying surface finishes. Eliminate tool marks on concrete surfaces.
 - (2.) Sawed Joints: Form contraction joints with power saws equipped with shatterproof abrasive or diamond-rimmed blades. Cut 1/8-inch wide joints into concrete when cutting action will not tear, abrade, or otherwise damage surface and before concrete develops random contraction cracks.
 - (d) Isolation Joints in Slabs-on-Grade: After removing formwork, install joint-filler strips at slab junctions with vertical surfaces, such

- as column pedestals, foundation walls, grade beams, and other locations, as indicated.
- (e) Waterstops: Install in construction joints and at other joints indicated according to manufacturer's written instructions.
- (6) Concrete placement:
- (a) Before placing concrete, verify that installation of formwork, reinforcement, and embedded items is complete and that the Required inspections have been performed.
 - (b) Deposit concrete continuously in one layer, or in horizontal layers, of such thickness that no new concrete will be placed on concrete that has hardened enough to cause seams or planes of weakness. If a section cannot be placed continuously, provide construction joints as indicated. Deposit concrete to avoid segregation.
 - (1.) Consolidate placed concrete with mechanical vibrating equipment according to ACI 301.
 - (c) Cold-Weather Placement: Comply with ACI 306.1.
 - (d) Hot-Weather Placement: Comply with ACI 301.
- (7) Finishing of formed surfaces:
- (a) Rough-Formed Finish: As-cast concrete texture imparted by forming material with tie holes and defects are to be repaired and patched. Remove fins and other projections that exceed specified limits on formed-surface irregularities.
 - (1.) Apply to concrete surfaces as indicated on plans.
 - (b) Smooth-Formed Finish: As-cast concrete texture imparts forming material with tie holes and defects are to be repaired and patched. Remove fins and other projections that exceed specified limits on formed-surface irregularities.
 - (1.) Apply to concrete surfaces as indicated on plans.
 - (c) Rubbed Finish: Apply the following to smooth-formed finished as-cast concrete where indicated:
 - (1.) Smooth-Rubbed Finish.
 - (2.) Grout-Cleaned Finish.
 - (3.) Cork-Floated Finish.
 - (d) Related Unformed Surfaces: At tops of walls, horizontal offsets, and similar unformed surfaces adjacent to formed surfaces, strike off smooth and finish with a texture matching adjacent formed surfaces. Continue final surface treatment of formed surfaces uniformly across adjacent unformed surfaces unless otherwise indicated.
- (8) Finishing of floors and slabs:
- (a) Comply with ACI 302.1R - 'Recommendations for screeding, re-straightening, and finishing operations for concrete surfaces'. Do not wet concrete surfaces.

- (b) Scratch Finish: While still plastic, texture concrete surface that has been screeded and bull-floated or darbied. Use stiff brushes, brooms, or rakes to produce profile amplitude of 1/4 inch in one direction.
 - (1.) Apply scratch finish to surfaces as indicated on drawings.
 - (c) Float Finish: Consolidate surface with power-driven floats or by hand floating if area is small or inaccessible to power driven floats. Restraighten, cut down high spots, and fill low spots. Repeat float passes and restraightening until surface is left with a uniform, smooth, granular texture.
 - (1.) Apply float finish to surfaces as indicated on drawings.
 - (d) Trowel Finish: After applying float finish, apply first troweling and consolidate concrete by hand or power-driven trowel. Continue troweling passes and restraighten until surface is free of trowel marks and uniform in texture and appearance. Grind smooth any surface defects that would telegraph through applied coatings or floor coverings.
 - (1.) Apply a trowel finish to surfaces as indicated on drawings.
 - (2.) Finish and measure surface so gap at any point between concrete surface and an unveled, freestanding, 10-ft long straightedge resting on two high spots and placed anywhere on the surface does not exceed specified clearance.
 - (e) Trowel and Fine-Broom Finish: First, apply a trowel finish to the surfaces indicated. While the concrete is still plastic, slightly scarify surface with a fine broom.
 - (1.) Comply with flatness and levelness tolerances for trowel-finished floor surfaces.
 - (f) Broom Finish: Apply a broom finish to exterior concrete platforms, steps, ramps, and elsewhere as indicated.
- (9) Concrete protection and curing:
- (a) Freshly placed concrete is to be protected from premature drying and excessive cold or hot temperatures. Comply with ACI 306.1 for cold-weather protection and ACI 301 for hot-weather protection during curing.
 - (b) Evaporation retarder: Apply evaporation retarder to unformed concrete surfaces if hot, dry, or windy conditions cause moisture loss approaching 0.2 lb/sq. ft. x h before and during finishing operations. Apply according to manufacturer's written instructions after placing, screeding, and bull floating or darbying concrete, but before float finishing.
 - (c) The curing of concrete according to ACI 308.1, by one or a combination of the following methods:
 - (1.) Moisture Curing.
 - (2.) Moisture-Retaining-Cover Curing.

- (3.) Curing Compound.
Removal: After curing period has elapsed, remove curing compound without damaging concrete surfaces by method recommended by curing compound manufacturer.
- (4.) Curing and Sealing Compound.
- (10) Concrete surface repairs:
 - (a) Defective Concrete: Repair and patch defective areas when approved by the Design Professional. Remove and replace concrete that cannot be repaired and patched to the Design Professional's approval.
- (11) Field quality control:
 - (a) Testing and Inspecting: Specify that UM will engage a qualified testing and inspecting agency to perform field tests and inspections and prepare test reports.
- (12) Level the concrete slab per the ACI recommended tolerance, compatible with intended floor finish.

03 33 00 Architectural Concrete

Design Standards

1. For Architectural concrete, provide the following:
 - a. LEED submittals:
 - (1) Product data for Credit MR 4.
 - (2) Product data for Credit IEQ 4.3
 - (3) Design mixture for Credit ID 1.1
 - b. Submittal of formwork shop drawings.
 - c. Submittal of samples for each of the following materials:
 - (1) Form-facing panel.
 - (2) Form ties.
 - (3) Form liners.
 - (4) Coarse- and fine-aggregate gradations.
 - (5) Chamfers and rustications.
 - d. Form-facing materials:
 - (1) Form-facing panels for as-cast or exposed-aggregate finishes: Steel, glass-fiber-reinforced plastic or other approved non-absorptive panel materials that will provide continuous, true, and smooth architectural concrete surfaces.

- (2) Form Liners if required: Units of face design, texture, arrangement, and configuration indicated or to match design reference sample. Furnish with manufacturer's recommended liquid-release agent that will not bond with, stain, or adversely affect concrete surfaces and will not impair subsequent surface treatments of concrete.
 - (3) Rustication Strips if required: Metal, rigid plastic or dressed wood with sides beveled and back kerfed; non-staining.
 - (4) Chamfer Strips if required: Metal, rigid plastic, elastomeric rubber, or dressed wood, 3/4 by 3/4 inch minimum; non-staining.
 - (5) Form Joint Tape if required: Compressible foam tape; pressure sensitive; AAMA 800, "Specification 810.1, Expanded Cellular Glazing Tape"; minimum 1/4 inch.
 - (6) Form Ties: Factory-fabricated, [glass-fiber-reinforced plastic] [internally disconnecting] [or] [removable] ties designed to resist lateral pressure of fresh concrete on forms and to prevent spalling of concrete on removal.
- e. Cast-in-place materials:
- (1) Steel reinforcing as follows:
 - (a) Refer to Section 03 30 00 Cast-in-Place Concrete.
 - (b) Recycled content of steel products: Post-consumer recycled content plus one-half of pre-consumer recycled content not less than 25 percent.
 - (c) Bar Supports: Bolsters, chairs, spacers, and other devices for spacing, supporting, and fastening reinforcing bars and welded wire reinforcement in place.
 - (1.) Where legs of wire bar supports contact forms, use gray, all-plastic, CRSI Class 1, gray, plastic-protected or CRSI Class 2, stainless-steel bar supports.
 - (2) Concrete materials as follows:
 - (a) Cementitious Material: Use the same cementitious materials, of the same type, brand, and source, throughout the same project:
 - (b) Portland cement: ASTM C150 gray or white. Supplement if required with the following:
 - (1.) Fly Ash: ASTM C618, Class F or C.
 - (2.) Ground granulated blast-furnace slag: ASTM C989, Grade 100 or 120.
 - (c) Blended hydraulic cement: ASTM C595, Type IS, portland blast-furnace slag, Type IP, portland-pozzolan, Type I (PM), pozzolan-modified Portland or Type I (SM), slag-modified portland cement, if required.
 - (3) Normal-weight aggregates: ASTM C33, graded.
 - (a) Maximum coarse-aggregate size as required.
 - (b) Fine Aggregate if required; free of materials with deleterious reactivity to alkali in cement.

- (4) Light-weight aggregates as per ASTM C330. Specify nominal maximum aggregate size.
- (5) Water as per ASTM C94 or potable.
- (6) Admixtures when required:
 - (a) Air-entraining admixture: ASTM C260.
 - (b) Chemical admixtures:
 - (1.) Admixtures to be certified by manufacturer to be compatible with other admixtures and that will not contribute water-soluble chloride ions exceeding those permitted in hardened concrete. Do not accept the use of calcium chloride or of admixtures containing calcium chloride.
 - (2.) Water-Reducing Admixture: ASTM C494, Type A.
 - (3.) Retarding Admixture: ASTM C494, Type B.
 - (4.) Water-Reducing and Retarding Admixture: ASTM C494, Type D.
 - (5.) High-Range, Water-Reducing Admixture: ASTM C494, Type F.
 - (6.) High-Range, Water-Reducing and Retarding Admixture: ASTM C494, Type G.
 - (7.) Plasticizing and Retarding Admixture: ASTM C1017, Type II.
- (7) Color Pigment: ASTM C 979, synthetic mineral-oxide pigments or colored water-reducing admixtures; color stable, free of carbon black, non-fading, and resistant to lime and other alkalis.
- (8) Curing materials if required:
 - (a) Absorptive Cover: AASHTO M182, Class 2, burlap cloth made from jute or kenaf.
 - (b) Moisture-Retaining Cover: ASTM C171, polyethylene film or white burlap-polyethylene sheet.
 - (c) Water: Potable.
 - (d) Clear, Waterborne, Membrane-Forming Curing Compound: ASTM C309, Type 1, Class B.
 - (1.) For integrally colored concrete, curing compound shall be pigmented type approved by color pigment manufacturer.
 - (2.) For concrete indicated to be sealed, curing compound shall be compatible with sealer.
- (9) Concrete mixtures:
 - (a) Prepare design mixtures for each type and strength of concrete, proportioned based on laboratory trial mixture or field test data, or both, according to ACI 301.
 - (b) Cementitious Materials: Use fly ash, pozzolan, ground granulated blast-furnace slag, and silica fume as needed to reduce the total amount of Portland cement, which would otherwise be used, by not less than 40 percent.

- (d) Proportion concrete mixture as follows:
 - (1.) Specify Minimum Compressive Strength at 28 days.
 - (2.) Specify Maximum Water-Cementitious Materials Ratio.
 - (3.) Specify Slump limit.
 - (4.) Specify air content.
 - (5.) Specify micro-fibers if required.

- (10) Concrete mixing:
 - (a) Ready-Mixed Concrete: Measure, batch, mix, and deliver concrete according to ASTM C94 and ASTM C 1116 and furnish batch ticket information.
 - (1.) Clean equipment used to mix and deliver cast-in-place architectural concrete to prevent contamination from other concrete.
 - (2.) When air temperature is between 85 and 90 deg F, reduce mixing and delivery time from 1-1/2 hours to 75 minutes; when air temperature is above 90 deg F, reduce mixing and delivery time to 60 minutes.

- c. Execution of concrete work as follows:
 - (1) Formwork:
 - (a) Refer to Section 03 30 00 Cast-in-Place Concrete for formwork, embedded items and shoring and re-shoring.
 - (b) Limit deflection of form-facing panels to not exceed ACI 303.1 requirements.
 - (c) In addition to ACI 303.1 limits on form-facing panel deflection, limit cast-in-place architectural concrete surface irregularities, designated by ACI 347 as abrupt or gradual, as follows:
 - (1.) Class A, 1/8 inch.
 - (d) Fabricate forms to result in cast-in-place architectural concrete that complies with ACI 117, "Specifications for Tolerances for Concrete Construction and Materials."
 - (e) Clean forms and adjacent surfaces to receive concrete. Remove chips, wood, sawdust, dirt, and other debris just before placing concrete.
 - (f) Retighten forms and bracing before placing concrete, as required, to prevent mortar leaks and maintain proper alignment.
 - (g) Place form liners accurately to provide finished surface texture indicated. Provide solid backing and attach securely to prevent deflection and maintain stability of liners during concreting. Prevent form liners from sagging and stretching in hot weather. Seal joints of form liners and form liner accessories to prevent mortar leaks. Coat form liner with form-release agent.

- (2) Reinforcement and inserts:
 - (a) Refer to Section 03 30 00 "Cast-in-Place Concrete" for fabricating and installing steel reinforcement. Securely fasten steel reinforcement and wire ties against shifting during concrete placement.
 - (b) Set wire ties with ends directed into concrete, not toward exposed concrete surfaces.

- (3) Removing and re-using of forms:
 - (a) Formwork for sides of beams, walls, columns, and similar parts of the work that does not support weight of concrete may be removed after cumulatively curing at not less than 50 deg F for 24 hours after placing concrete if concrete is hard enough to not be damaged by form-removal operations and curing and protection operations are maintained.
 - (1.) Cut off and grind glass-fiber-reinforced plastic form ties flush with surface of concrete.
 - (b) Leave formwork for beam soffits, joists, slabs, and other structural elements that support weight of concrete in place until concrete has achieved 28-day design compressive strength. Remove forms only if shores have been arranged to permit removal of forms without loosening or disturbing shores.
 - (c) When forms are reused, clean surfaces, remove fins and laitance, and tighten to close joints. Align and secure joints to avoid offsets. Do not use patched forms for cast-in-place architectural concrete surfaces.

- (4) Joints:
 - (a) Install construction joints true to line with faces perpendicular to surface plane of cast-in-place architectural concrete so strength and appearance of concrete are not impaired, at locations indicated or as approved by the Design Professional.
 - (1.) Place joints perpendicular to main reinforcement. Continue reinforcement across construction joints unless otherwise indicated.
 - (b) Contraction joints: Form weakened-plane contraction joints true to line with faces perpendicular to surface plane of cast-in-place architectural concrete so strength and appearance of concrete are not impaired, at locations indicated or as approved by Design Professional.

- (4) Concrete placement:
 - (a) Before placing concrete, verify that installation of formwork, reinforcement, and embedded items is complete and that required inspections have been performed.

- (b) Deposit concrete continuously in one layer or in horizontal layers of such thickness that no new concrete will be placed on concrete that has hardened enough to cause seams or planes of weakness. If a section cannot be placed continuously, provide construction joints as indicated. Deposit concrete to avoid segregation.
 - (1.) Consolidate placed concrete with mechanical vibrating equipment according to ACI 301.
 - (c) Cold-weather placement: Comply with ACI 306.1.
 - (d) Hot-weather placement: Comply with ACI 301.
- (5) Finishing of formed surfaces:
- (a) Architectural concrete finish: Match the Design Professional's design reference sample, identified and described as indicated, to satisfaction of the Design Professional.
 - (b) Related unformed surfaces: At tops of walls, horizontal offsets, and similar unformed surfaces adjacent to formed surfaces, strike off smooth and finish with a texture matching adjacent formed surfaces.
 - (1.) Continue final surface treatment of formed surfaces uniformly across adjacent unformed surfaces unless otherwise indicated.
 - (d) Maintain uniformity of special finishes over construction joints unless otherwise indicated.
 - (e) Form-liner finish: Produce a textured surface free of pockets, streaks, and honeycombs, and of uniform appearance, color, and texture.
 - (f) Scrubbed finish if required: After concrete has achieved a compressive strength of from 1000 to 1500 psi apply scrubbed finish. Wet concrete surfaces thoroughly and scrub with stiff fiber or wire brushes, using water freely, until top mortar surface is removed and aggregate is uniformly exposed. Rinse scrubbed surfaces with clean water. Maintain continuity of finish on each surface or area of Work. Remove only enough concrete mortar from surfaces to match design reference sample or mockup.
 - (g) High-pressure water-jet finish if required: Perform high-pressure water jetting on concrete that has achieved a minimum compressive strength of 4500 psi. Coordinate with formwork removal to ensure that surfaces to be high-pressure water-jet finished are treated at same age for uniform results.
 - (h) Abrasive-blast finish: Perform abrasive blasting after compressive strength of concrete exceeds 2000 psi. Coordinate with formwork removal to ensure that surfaces to be abrasive blasted are treated at same age for uniform results. Use an abrasive grit of proper type and gradation to expose aggregate and surrounding matrix surfaces to match design reference sample or mockup, as follows:

- (1.) Brush: Remove cement matrix to dull surface sheen and expose face of fine aggregate; with no significant reveal.
- (2.) Light: Expose fine aggregate with occasional exposure of coarse aggregate and uniform color; with maximum reveal of 1/16 inch.
- (3.) Medium: Generally expose coarse aggregate; with slight reveal, a maximum of 1/4 inch.
- (4.) Heavy: Expose and reveal coarse aggregate to a maximum projection of one-third its diameter; with reveal range of 1/4 to 1/2 inch.
- (i) Bush hammer finish if required: Allow concrete to cure at least 14 days before starting bushhammer surface finish operations.
 - (1.) Surface Continuity: Perform bushhammer finishing in as continuous an operation as possible, maintaining continuity of finish on each surface or area of Work. Maintain required patterns or variances of cut as shown on Drawings or to match design reference sample or mockup.
 - (2.) Surface Cut: Maintain required depth of cut and general aggregate exposure.
- (6) Concrete curing:
 - (a) Begin curing cast-in-place architectural concrete immediately after removing forms from or applying as-cast formed finishes to concrete. Cure according to ACI 308.1, by one or a combination of the following methods that will not mottle, discolor, or stain concrete:
 - (1.) Moisture Curing.
 - (2.) Moisture-Retaining-Cover Curing.
 - (3.) Curing Compound.
- (7) Concrete surface repairs:
 - (a) Defective Concrete: Repair and patch defective areas when approved by the Design Professional. Remove and replace concrete that cannot be repaired and patched to the Design Professional's approval.
 - (b) Protect corners, edges, and surfaces of cast-in-place architectural concrete from damage; use guards and barricades.
 - (c) Protect cast-in-place architectural concrete from staining, laitance, and contamination during remainder of construction period.
- (8) Field quality control:
 - (a) Testing and Inspecting: Specify that UM will engage a qualified testing and inspecting agency to perform field tests and inspections and prepare test reports.

03 38 16 Unbonded Post-Tensioned concrete**Design Standards**

1. The Design Professional shall design the unbonded post-tensioned concrete as follows:
 - a. LEED submittals:
 - (1) Product data for Credit MR 4.
 - b. Shop drawings submittal:
 - (1) Shop drawings to be prepared by or under the supervision of a qualified professional engineer, detailing tendon layout and installation procedures.
 - (2) If a delegated-design submittal for post-tensioning system is required then, sealed design calculations prepared by a qualified structural engineer indicating method of elongation calculation including values used for friction coefficients, anchorage seating loss, elastic shortening, creep, relaxation, and shrinkage, will be required.
 - c. Informational submittals:
 - (1) Qualification Data: For installer, manufacturer and testing agency.
 - (2) Product certificates.
 - (3) Mill Test Reports: For prestressing strand.
 - (4) Field quality-control reports.
 - (5) Stressing Records: Submit the same day as stressing operations.
 - d. Quality assurance procedures:
 - (1) Manufacturer qualifications:
 - (a) Fabricating plant certified by PTI according to procedures set forth in PTI's "Manual for Certification of Plants Producing Unbonded Single Strand Tendons".
 - (2) Installer qualifications:
 - (a) A qualified installer whose full-time Project superintendent has successfully completed PTI's Level 1 - Field Fundamentals course or has equivalent verifiable experience and knowledge acceptable to the Design Professional.
 - (b) Superintendent must receive training from post-tensioning supplier in the operation of stressing equipment to be used on project.
 - (3) UM testing agency shall be qualified according to ASTM E 329 for indicated testing.
 - (a) Testing Agency Inspector: Personnel performing field inspections and measuring elongations shall have successfully completed PTI's Level 1 - Field Fundamentals course or shall have equivalent verifiable experience and knowledge acceptable to the Design Professional.
 - (4) Delivery, storage, and handling of post-tensioning materials shall be according to PTI's "Field Procedures Manual for Un-bonded Single Strand Tendons."

- e. Performance requirements:
- (1) If a delegated design is used, then a qualified professional engineer, as defined in Section 014000 "Quality Requirements" of the project's specifications, needs to be engaged to design post-tensioned reinforcement.
 - (a) Design cast-in-place, post-tensioned concrete reinforcement as indicated in this Section. Show final effective forces, tendon profiles, and non-prestressed reinforcement on design installation drawings.
 - (2) Design structure to withstand the loads indicated according to governing codes, within limits and under conditions indicated.
 - (3) Average pre-compression:
 - (a) Minimum average slab pre-compression.
 - (b) Maximum average slab pre-compression.
 - (c) Minimum average pre-compression in T-, L-, and rectangular-beam cross sections.
 - (d) Minimum pre-compression in slab section not included in T- or L-beam section.
 - (e) A maximum pre-compression in transfer girders. Specify stage-stressing sequence to avoid overstress.
 - (4) Comply with ACI 318 requirements unless more stringent requirements are specified.
 - (5) Fire Resistance: Design members such that thickness and concrete cover over reinforcement comply with fire-resistance requirements of authorities having jurisdiction.
 - (6) Deflection Limits Including creep and shrinkage effects.
 - (7) The closure strips shall be at mid-span and that tendon forces and profiles be adjusted accordingly. Calculate moments in spans with closure strips assuming a continuous slab. Provide only non-prestressed reinforcement within closure strips. Design reinforcement in closure strip to carry ultimate moment at midspan.
- f. Pre-stressing tendons:
- (1) Comply with ACI 423.6, "Specification for Unbonded Single Strand Tendons," unless otherwise indicated in the Contract Documents.
 - (2) Pre-stressing strand: ASTM A416/, Grade 270, uncoated, seven-wire, low-relaxation, diameter strand.
 - (3) Post-tensioning Coating: Compound with friction-reducing, moisture-displacing, and corrosion-inhibiting properties; chemically stable and nonreactive with pre-stressing steel, non-pre-stressed reinforcement, sheathing material, and concrete.
 - (4) Tendon sheathing:
 - (a) Minimum Thickness: 0.050 inch for polyethylene or polypropylene with a minimum density of 0.034 lb/cu. in.
 - (b) Tendon sheathing shall be continuous over length of tendon to provide watertight encapsulation of strand and between anchorages to prevent intrusion of cement paste or loss of coating for a non-encapsulated system.

- (5) Anchorage device and coupler assembly:
 - (a) Assembly of strand, wedges, and anchorage device or coupler complying with static and fatigue testing requirements and capable of developing 95 percent of actual breaking strength of strand.
- (6) Encapsulation system if required: Watertight encapsulation of pre-stressing strand consisting of the following:
 - (a) Wedge-cavity caps: Attached to anchorages with a positive mechanical connection and completely filled with post-tensioning coating.
 - (b) Sleeves: Attached to anchorage device with positive mechanical connection; overlapped a minimum of 4 inches with sheathing and completely filled with post-tensioning coating.
- g. Non-pre-stressed steel bars:
 - (1) Recycled content of steel products: Post-consumer recycled content plus one-half of pre-consumer recycled content a minimum of 60 percent.
 - (2) Support bars, reinforcing bars, hairpins:
 - (a) Steel: ASTM A 615, Grade 60, deformed.
 - (b) Low-Alloy Steel: ASTM A 706, deformed for welding and where required.
 - (3) Supports: Bolsters, chairs, spacers, and other devices for spacing, supporting, and fastening tendons and tendon support bars in place. Manufacture bar supports, according to CRSI's "Manual of Standard Practice," from steel wire, plastic, or precast concrete of greater compressive strength than concrete, and as follows:
 - (a) For uncoated bars, use all plastic, CRSI Class 1 plastic-protected or CRSI Class 2 stainless-steel bar supports.
- h. Accessories:
 - (1) Pocket formers: Capable of completely sealing wedge cavity; sized to provide the required cover over the anchorage and allow access for cutting strand tail.
 - (2) Anchorage fasteners as required: Stainless, galvanized, uncoated-steel nails, wires, and screws used to attach anchorage devices to formwork.
 - (3) Sheathing Repair Tape if required: Elastic, self-adhesive, moisture-proof tape with minimum width of 2 inches, in contrasting color to tendon sheathing; nonreactive with sheathing, coating, or pre-stressing steel.
- i. Patching material:
 - (1) One-component, polymer-modified, premixed patching material containing selected silica aggregates and Portland cement, suitable for vertical and overhead applications. Do not use material containing chlorides or other chemicals known to be deleterious to pre-stressing steel or material that is reactive with pre-stressing steel, anchorage device material, or concrete.

- j. Tendon installation:
- (1) Formwork:
 - (a) Provide formwork for post-tensioned elements as specified in Section 03 30 00 "Cast-in-Place Concrete." Design formwork to support load redistribution that may occur during stressing operation. Ensure that formwork does not restrain elastic shortening, camber, or deflection resulting from application of prestressing force.
 - (b) Do not remove forms supporting post-tensioned elements until tendons have been fully stressed and elongations have been approved by the Design Professional.
 - (c) Do not place concrete in supported floors until tendons on supporting floors have been stressed and elongations have been approved by the Design Professional.
 - (2) Non-pre-stressed steel reinforcing placement:
 - (a) Placement of non-prestressed steel reinforcement is specified in Section 033000 "Cast-in-Place Concrete." Coordinate placement of non-prestressed steel reinforcement with installation of post-tensioning tendons.
 - (3) Tendon installation:
 - (a) Install tendons according to installation drawings and procedures stated in PTI's "Field Procedures Manual for Unbonded Single Strand Tendons".
 - (1.) Tolerances: Comply with tolerances in ACI 423.6 for beams and slabs.
 - (4) Tendon supports: Provide continuous slab bolsters or bars supported on individual high chairs spaced at a maximum of 42 inches on center to ensure tendons remain in their designated positions during construction operations and concrete placement.
 - (a) Support tendons as required to provide profiles shown on installation drawings. Position supports at high and low points and at intervals not exceeding 48 inches. Ensure that tendon profiles between high and low points are smooth parabolic curves.
 - (b) Attach tendons to supporting chairs and reinforcement without damaging tendon sheathing.
 - (c) Support slab tendons independent of beam reinforcement.
 - (5) Tendon profile shall be maintained within maximum allowable deviations from design profile as follows:
 - (a) 1/4 inch for member depth less than or equal to 8 inches
 - (b) 3/8 inch for member depth greater than 8 inches and less than or equal to 24 inches.
 - (c) 1/2 inch for member depth greater than 24 inches.
 - (6) A minimum radius of curvature of 480-strand diameters shall be maintained for lateral deviations to avoid openings, ducts, and embedded items. A minimum of 2 inches (50 mm) of separation shall be maintained between tendons at locations of curvature.
 - (7) The limit of tendon bundles shall be five (5) tendons. Do not twist or entwine tendons within a bundle. Maintain a minimum distance of 12 inches between centers of adjacent bundles.

- (8) If tendon locations conflict with non-pre-stressed reinforcement or embedded items, tendon placement governs. Obtain the Design Professional's approval before relocating tendons or tendon anchorages that interfere with one another.
- (9) Deviations in horizontal spacing and location of slab tendons are permitted when required to avoid openings and inserts.
- (10) Installation of anchorage devices shall be as follows:
 - (a) Place anchorage devices at locations shown on approved installation drawings.
 - (b) Do not switch fixed- and stressing-end anchorage locations.
 - (c) Attach pocket formers, intermediate anchorage devices, and stressing-end anchorage devices securely to bulkhead forms. Install stressing-end and intermediate anchorage devices perpendicular to tendon axis.
 - (d) Install tendons straight, without vertical or horizontal curvature, for a minimum of 12 inches behind stressing-end and intermediate anchorages.
 - (e) Embed intermediate anchorage devices at construction joints in first concrete placed at joint.
 - (f) Minimum splice length in reinforcing bars at anchorages is 24 inches. Stagger splices a minimum of 60 inches.
 - (g) Place fixed-end anchorage devices in formwork at locations shown on installation drawings. Support anchorages firmly to avoid movement during concrete placement.
 - (h) Remove loose caps on fixed-end anchorages, refill with post-tensioning coating, and re-attach caps to achieve a watertight enclosure when required.
- (11) The minimum concrete cover shall be maintained according to ACI 423.6.
- (12) A minimum distance of six (6) inches shall be maintained between tendons and openings.
- (13) Tendon locations shall be marked on formwork with spray paint prior to concrete placement, if required.
- (14) Sleeves shall not be installed within 36 inches of anchorages after tendon layout has been inspected.
- (15) Specify the following:
 - (a) Do not install conduit, pipe, or embeds requiring movement of tendons after tendon layout has been inspected.
 - (b) Do not use couplers unless location has been approved by the Design Professional.
- (16) Sheathing inspection and repair as follows:
 - (a) Inspect sheathing for damage after installing tendons. Repair damaged areas by restoring post-tensioning coating and repairing or replacing tendon sheathing as required.
 - (1.) Ensure that sheathing is watertight and there are no air voids.
 - (2.) Follow tape repair procedures in PTI's "Field Procedures Manual for Unbonded Single Strand Tendons".

- (17) The maximum length of exposed strand behind anchorages shall be as follows:
 - (a) Fixed End: 12 inches.
 - (b) Intermediate and Stressing End: 1 inch.
 - (1.) Cover exposed strand with sheathing repair tape to prevent contact with concrete.
 - (18) Tendons that have a damaged strand shall be immediately removed and replaced.
- k. Concrete placement:
- (1) Place concrete as specified in Section 033000 "Cast-in-Place Concrete." Ensure compaction of concrete around anchorages.
 - (2) Ensure that position of tendon and non-prestressed-steel reinforcement does not change during concrete placement. Reposition tendons and non-prestressed-steel reinforcement moved during concrete placement to original location.
 - (3) Ensure that method of concrete placement does not damage tendon sheathing. Do not support pump lines, chutes, or other concrete-placing equipment on tendons.
- l. Tendon stressing:
- (1) Calibrate stressing jacks and gages at start of project and at least every six months thereafter if necessary. Keep copies of calibration certificates for each jack-and-gage pair on Project site that are available for inspection. Exercise care in handling stressing equipment to ensure that proper calibration is maintained.
 - (2) Stress tendons only under supervision of a qualified post-tensioning superintendent.
 - (3) Do not begin stressing operations until concrete strength has reached 3000 psi as indicated by compression tests of field-cured cylinders.
 - (4) Complete stressing within ninety six (96) hours of concrete placement.
 - (5) If concrete has not reached required strength, obtain Design Professional's approval to partially stress tendons and delay final stressing until concrete has reached required strength.
 - (6) Stage stress transfer girders and foundation mats if required according to schedule shown on the Contract Drawings.
 - (7) If detensioning and restressing of tendon is required, discard wedges used in original stressing and provide new wedges.
 - (8) Mark and measure elongations according to PTI's "Field Procedures Manual for Unbonded Single Strand Tendons." Measure elongations to closest 1/8 inch.
 - (9) Submit stressing records within one day of completion of stressing. If discrepancies between measured and calculated elongations exceed plus or minus seven (7) percent, resolve these discrepancies to satisfaction of the Design Professional.
 - (10) Prestressing will be considered acceptable if gage pressures shown on stressing record correspond to required stressing force and calculated and measured elongations agree within seven (7) percent.

- (11) If measured elongations deviate from calculated elongations by more than seven (7) percent, additional testing, restressing, strengthening, or replacing of affected elements may be required.
- m. Tendon finishing:
- (1) Do not cut strand tails or cover anchorages until stressing records have been reviewed and approved by the Design Professional.
 - (2) Cut strand tails as soon as possible after approval of elongations.
 - (3) Install caps and sleeves on intermediate anchorages within one day of stressing, if required.
 - (4) Cut strand tails and install caps on stressing-end anchorages within one day of the Design Professional's acceptance of elongations, if required.
 - (5) Patch stressing pockets within one day of cutting strand tail. Clean inside surface of pocket to remove laitance or post-tensioning coating before installing patch material. Finish patch material flush with adjacent concrete.
- n. Field quality control:
- (1) Testing Agency: Owner will engage a qualified testing agency to perform tests and inspections.
 - (2) Before concrete placement, testing agency will inspect the following for compliance with post-tensioning installation drawings and the Contract Documents:
 - (a) Location and number of tendons.
 - (b) Tendon profiles and covers.
 - (c) Installation of backup bars, hairpins, and other non-prestressed reinforcement shown on post-tensioning installation drawings.
 - (d) Installation of pocket formers and anchorage devices.
 - (e) Repair of damaged sheathing.
 - (f) Connections between sheathing and anchorage devices, if required.
 - (3) Testing agency will record tendon elongations during stressing.
 - (4) Testing agency will immediately report deviations from the Contract Documents to the Design Professional.
- o. Work protection:
- (1) Do not expose tendons to electric ground currents, welding sparks, or temperatures that would degrade components.
 - (2) Protect exposed components within one workday of their exposure during installation.
 - (3) Prevent water from entering tendons during installation and stressing.
 - (4) Provide weather protection to stressing-end anchorages if strand tails are not cut within 10 days of stressing the tendons.
- p. Repairs:
- (1) Submit repair procedure to the Design Professional for evaluation and approval.
 - (2) Do not proceed with repairs requiring removal of concrete unless authorized in writing by the Design Professional.

DIVISION 04 MASONRY

This chapter identifies criteria for masonry design in University of Miami (UM) Buildings and on the site with the purpose of establishing minimum standards, acceptable to UM, to be used as the basis of design for construction and maintenance of the UM Coral Gables Campus.

- 04.1 General Requirements
 - 04.1.1 Submittals
- 04.2 Codes and Standards
 - 04.2.1 Concrete Unit Masonry
- 04.3 Design Criteria
 - 04.3.1 Concrete Unit Masonry
- 04.4 Specific Masonry Requirements (organized by CSI MasterFormat® 2012 Numbers & Titles)

04.1 General Requirements

All work shall be designed by a Professional Structural Engineer licensed in the State of Florida.

At the University's discretion before the start of construction on new buildings and/or major renovations, the Contractor shall provide a drawing for each building floor level showing the coordination of all structural, architectural and MEP items. This includes, but is not limited to: Structural members, floor plates, architectural ceilings, soffits, smoke barriers, fire walls, vertical shafts, sleeves, fire dampers, HVAC ductwork and equipment, plumbing piping and equipment, fire protection piping and equipment, alarm systems, communications, electrical distribution and equipment, lighting, controls, BMS, lighting protection, security systems, etc.

UM Coral Gables Campus and UM Buildings masonry design must comply with the following objectives:

1. Sustainable Design.
2. Flexibility to allow for major and minor alterations which will occur during the typical building's life span, without causing major disruptions to other areas of the building.
3. High level of integration between architecture and the engineering systems using the latest advancements in technology.
4. Solutions with the best value considering a life cycle cost analysis to account for the total project cost.

The design of masonry buildings and structures, in concert with other building components, shall produce a building that meets the programmed sustainability rating (LEED rating) of the specific project.

04.1.1 Submittals

Submittals shall include product data, samples, and shop drawings which are coordinated with all corresponding disciplines. The Design Professional must ensure that all submittals and shop drawings are coordinated with other disciplines.

04.2 Codes and Standards

04.2.1 Unit Masonry and Concrete Unit Masonry

The Unit Masonry and Concrete Unit Masonry design shall comply with the requirements of the applicable authorities having jurisdiction, and with the in-force edition at the time of the project of the following codes and standards:

1. American Society of Testing and Materials (ASTM)
2. American Concrete Institute (ACI)
3. The Masonry Society (TMS)
4. National Concrete Masonry Association (NCMA)
5. Portland Cement Association (PCA)
6. American Society of Civil Engineers (ASCE)
7. Sheet Metal and Air Conditioning Contractor’s National Association (SMACNA)

04.3 Design Criteria

04.3.1 Concrete Unit Masonry

1. Concrete Unit Masonry should include the following:
 - a. Interior masonry walls designed to resist 5 psf lateral pressures, per Florida Building Code.
 - b. Exterior masonry walls designed to resist lateral wind pressures, per Florida Building Code and ASCE7.
 - c. Interior and exterior load bearing masonry walls to resist gravity loads, per Florida Building Code.
 - d. Provide reinforced masonry per ACI 530 / ASCE5 or tie beams and columns within the masonry walls to resist wind pressures and gravity loads per Florida Building Code and ASCE7.
 - e. Provide waterproofing prior to veneer finishes, compatible with the bonding requirements of the finish system.

04.4 Specific requirements (organized by CSI MasterFormat® 2012 Numbers & Titles)

04 22 00	Concrete Unit Masonry
----------	-----------------------

04 22 00 Concrete Unit Masonry

Design Standards

1. The design of concrete unit masonry is to include the following:
 - a. LEED submittals:
 - 1) Product data for Credit MR 5.

- b. General requirements for masonry units:
 - 1) Use of defective units: Referenced masonry unit standards may allow a certain percentage of units to contain chips, cracks, or other defects exceeding limits stated in the standard. Do not use units where such defects will be exposed in the completed work.
 - 2) Fire-resistance ratings: Where indicated, provide units that comply with requirements for fire-resistance ratings indicated as determined by testing according to ASTM E119, by equivalent masonry thickness, or by other means, as acceptable to authorities having jurisdiction.

- c. Concrete masonry units (CMU):
 - 1) Regional materials: CMUs shall be manufactured within 500 miles of project site from aggregates and cement that have been extracted, harvested, or recovered, as well as manufactured, within 500 miles of project site.
 - a) Shapes: Provide shapes indicated and for lintels, corners, jambs, sashes, movement joints, headers, bonding, and other special conditions.
 - 2) Concrete masonry units (CMU) are to comply with ASTM C90.
 - 3) Decorative concrete masonry units are to comply with ASTM C90.
Patterns to be as follows:
 - a) Standard pattern, ground-face finish.
 - b) Standard pattern, split-face finish.
 - c) Standard pattern, split-ribbed finish.
 - d) Scored vertically, standard finish.
 - 4) Pre-faced concrete masonry units are to comply with ASTM C90: Lightweight hollow or solid concrete units are to comply with ASTM C90, with manufacturer's standard smooth resinous facing complying with ASTM C744.
 - a) Colors and Patterns: As selected by Design Professional from manufacturer's full range.
 - 5) Concrete and masonry lintels to be designed as follows:
 - a) Concrete lintels: ASTM C1623, are to match CMUs in color, texture, and density classification; and with reinforcing bars indicated. Provide lintels with net-area compressive strength not less than CMUs. Lintels shall have Miami-Dade County or State of Florida product acceptance (NOA).
 - b) Concrete Lintels: Precast or formed-in-place concrete lintels complying with requirements in Section 033000 "Cast-in-Place Concrete" and with reinforcing bars indicated.
 - c) Masonry Lintels: Prefabricated or built-in-place masonry lintels, made from bond beam CMUs with reinforcing bars placed as indicated and filled with coarse grout.

- d. Mortar and grout materials:
 - 1) Regional materials: Aggregate for mortar and grout, cement, and lime shall be extracted, harvested, or recovered, as well as manufactured, within 500 miles of project site.

- 2) Portland cement: ASTM C150, Type I or II. Provide natural color or white cement as required to produce mortar color indicated.
 - 3) Hydrated lime shall comply with ASTM C207, Type S.
 - 4) Portland cement-lime mix to be a packaged blend of Portland cement and hydrated lime containing no other ingredients.
 - 5) Masonry cement shall comply with ASTM C91.
 - 6) Mortar cement shall comply with ASTM C1329.
 - 7) Mortar Pigments: Use natural and synthetic iron oxides and chromium oxides, compounded for use in mortar mixes and complying with ASTM C979. Use only pigments with a record of satisfactory performance in masonry mortar.
 - 8) Colored cement product: Packaged blend made from Portland cement and hydrated lime, masonry cement or mortar cement and mortar pigments, all complying with specified requirements, and containing no other ingredients.
 - 9) Aggregates for mortar shall comply with ASTM C144.
 - 10) Aggregates for grout shall comply with ASTM C404.
 - 11) Water-repellent admixture: Use liquid water-repellent mortar admixture intended for use with CMUs, containing integral water repellent by same manufacturer.
 - 12) Water shall be potable.
- e. Reinforcing materials:
- 1) Uncoated steel reinforcing bars to comply with ASTM A615 or ASTM A 996, Grade 60.
 - 2) General masonry joint reinforcement to comply with ASTM A951.
- f. Ties and anchor materials:
- 1) Materials: Provide ties and anchors that are made from materials that comply with the following unless otherwise indicated.
 - a) Hot-dip galvanized, carbon-steel wire: ASTM A82; with ASTM A153, Class B-2 coating.
 - b) Steel sheet, galvanized after fabrication: ASTM A1008, Commercial Steel, with ASTM A153, Class B coating.
 - c) Steel Plates, Shapes, and Bars: ASTM A36.
 - 2) Adjustable anchors for connecting to structural steel framing.
 - 3) Adjustable anchors for connecting to concrete.
 - 4) Partition top anchors.
 - 5) Rigid anchors.
 - 6) Anchor bolts.
- g. Embedded flashing materials:
- 1) Metal flashing to comply with SMACNA's "Architectural Sheet Metal Manual and as follows:
 - a) Metal drip edge.
 - b) Metal sealant stop
 - 2) Specify one of the following flexible flashings:
 - a) Copper-Laminated Flashing.
 - b) Rubberized-Asphalt Flashing.

- c) Elastomeric Thermoplastic Flashing.
 - d) Ethylene Propylene Diene Terpolymer (EPDM) Flashing.
 - 3) Single-wythe CMU flashing system if required.
 - 4) Solder and sealants for sheet metal flashings.
 - 5) Adhesives, primers, and seam tapes for flashings.
- h. Miscellaneous masonry accessories as required:
 - 1) Compressible filler preformed control-joint gaskets and bond-breaker strips.
- i. Masonry cell insulation:
 - 1) Loose-granular fill insulation or molded-polystyrene insulation units as required.
- j. Mortar and grout mixes:
 - 1) General requirements:
 - a) Do not use admixtures, including pigments, air-entraining agents, accelerators, retarders, water-repellent agents, antifreeze compounds, or other admixtures unless otherwise indicated.
 - 2) Do not specify the use of calcium chloride in mortar or grout.
 - 3) Specify Portland cement-lime, masonry cement or mortar cement mortar unless otherwise indicated.
 - 4) Use pre-blended, dry mortar mix, when necessary.
 - 5) Mortar for unit masonry shall comply with ASTM C270.
 - 6) Pigmented mortar (if required): Use colored cement product or select and proportion pigments with other ingredients to produce color required. Do not add pigments to colored cement products.
 - a) Application: Use pigmented mortar for exposed mortar joints with the following units:
 - (1.) Decorative CMUs.
 - (2.) Pre-faced CMUs.
 - 7) Colored-aggregate mortar: Specify production of required mortar color by using colored aggregates and natural color or white cement as necessary to produce required mortar color.
 - a) Application: Use colored aggregate mortar for exposed mortar joints with the following units:
 - (1.) Decorative CMUs.
 - (2.) Pre-faced CMUs.
 - 8) Grout for unit masonry shall comply with ASTM C476.
- k. Installation of the works:
 - 1) Tolerances:
 - a) Specify dimensions and location of elements.
 - b) Specify lines and levels.
 - 2) Joints thicknesses.
 - 3) Parameters for the laying of masonry walls:
 - a) Specify the bond pattern in exposed masonry.
 - 4) Parameters for mortar bedding and jointing:

- a) Specify the cutting of joints flush for masonry walls to receive plaster or other direct applied unless otherwise indicated.
 - 5) Masonry-cell insulation (when required):
 - a) Specify the pouring of granular insulation into cavities to fill void spaces or the installation of molded-polystyrene insulation units into masonry unit cells before laying units.
 - 6) Masonry joint reinforcing.
 - 7) The anchoring of masonry to structural steel and concrete.
 - 8) Type and installation of flashing.
 - 9) Parameters for reinforced unit masonry installation.
- I. Field quality controls:
- 1) Testing and inspection: UM will engage special inspectors to perform tests and inspections and prepare reports. Inspectors will need access to scaffolding and work areas, as needed to perform tests and inspections. Retesting of materials that fail to meet specified requirements shall be done at Contractor's expense.
 - a) Inspections: Level 1 or Level 2 special inspections according to the "Florida Building Code" or the "International Building Code" as required.
 - b) Concrete masonry unit test: For each type of unit provided, as per ASTM C140 for compressive strength.
 - c) Mortar aggregate ratio test (Proportion Specification): For each mix provided, as per ASTM C780.
 - d) Grout test (Compressive Strength): For each mix provided, as per ASTM C1019.
- m. Parging parameters.
- n. Specify repairing, pointing and cleaning.
- 1) In-progress cleaning: Clean unit masonry, as work progresses, by dry brushing to remove mortar fins and smears before tooling joints.
 - 2) Final cleaning: After mortar is thoroughly set and cured, clean exposed masonry as follows:
 - a) Test cleaning methods on sample wall panel; leave one-half of panel un-cleaned for comparison purposes.
 - b) Clean concrete masonry by cleaning method indicated in NCMA TEK 8- 2A applicable to type of stain on exposed surfaces.

DIVISION 05 METALS

This chapter identifies for construction and maintenance criteria for the design of metals in University of Miami (UM) Buildings and site with the purpose of establishing minimum standards, acceptable to UM, to be used as the basis of design for construction and maintenance UM Coral Gables Campus buildings.

- 05.1 General Requirements
 - 05.1.1 Submittals
- 05.2 Codes and Standards
 - 05.2.1 Structural Steel Framing, Steel Joist Framing, Steel Decking, Cold-Formed Metal Framing, Cold-Formed Metal Trusses and Metal Fabrication.
- 05.3 Design Criteria
 - 05.3.1 Structural Steel Framing, Steel Joist Framing, Steel Decking, Cold-Formed Metal Framing, Cold-Formed Metal Trusses and Metal Fabrication.
- 05.4 Specific Metals Requirements (organized by CSI MasterFormat® 2012 Numbers & Titles)

05.1 General Requirements

All work shall be designed by a Professional Structural Engineer licensed in the State of Florida.

At the University's discretion before the start of construction on new buildings and/or major renovations, the Contractor shall provide a drawing for each building floor level showing the coordination of all structural, architectural and MEP items. This includes, but is not limited to: Structural members, floor plates, architectural ceilings, soffits, smoke barriers, fire walls, vertical shafts, sleeves, fire dampers, HVAC ductwork and equipment, plumbing piping and equipment, fire protection piping and equipment, alarm systems, communications, electrical distribution and equipment, lighting, controls, BMS, lighting protection, security systems, etc.

The following information shall be obtained from the UM Project Manager:

1. Geotechnical investigation reports

UM Coral Gables Campus and UM Buildings steel must be designed to comply with the following objectives:

1. Sustainable Design.
2. Flexibility to allow for major and minor alterations which will occur during the typical building's life span, without causing major disruptions to other areas of the building.
3. High level of integration between architecture and the engineering systems using the latest advancements in technology.
4. Solutions with the best value considering a life cycle cost analysis to account for the total project cost.

The design of steel systems, in concert with other building components, shall produce a building that meets the programmed sustainability rating (LEED rating) of the specific project.

05.1.1 Submittals

Submittals shall include product data, samples, and shop drawings which are coordinated with all corresponding disciplines. The Design Professional must insure that all submittals and shop drawings are coordinated with other disciplines.

05.2 Codes and Standards

The design for Structural Steel Framing, Steel Joist Framing, Steel Decking, Cold-Formed Metal Framing, Cold-Formed Metal Trusses and Metal Fabrication shall comply with the requirements of the applicable authorities having jurisdiction, and with the in-force edition at the time of the project of the following codes and standards:

1. American Society of Testing and Materials (ASTM)
2. American Institute of Steel Construction (AISC)
3. Steel Construction Manual
5. American National Standards Institute (ANSI)
6. The Society for Protective Coatings (SSPC)
7. Research Council on Structural Connections (RCSC)
8. American Welding Society (AWS)
9. Steel Joist Institute (SJI)
10. American Iron and Steel Institute (AISI)
11. Cold-Formed Steel Engineers Institute (CFSEI)
12. Masters Painters Institute (MPI)
13. Sheet Metal and Air Conditioning Contractor's National Association (SMACNA)
14. Military Specification (MIL)

05.3 Design Criteria

05.3.1 Structural Steel Framing, Steel Joist Framing, Steel Decking, Cold-Formed Metal Framing, Cold-Formed Metal Trusses and Metal Fabrication.

The Design Professional shall specify the Structural Steel Framing, Steel Joist Framing, Steel Decking, Cold-Formed Metal Framing, Cold-Formed Metal Trusses and Metal Fabrication covered in this section.

1. Structural Steel Framing:
 - a. Structural steel framing members shall be designed to resist gravity and lateral load effects as per the Florida Building Code and ASCE-7 in compliance with high velocity wind zones (HVWZ) requirements.
 - b. Lateral load resisting systems shall be designed so that lateral drift does not exceed HEIGHT/400 for a wind return period of 10 years.
 - c. Structural steel shall be designed as per the current AISC Steel Construction Manual utilizing ASD or LRFD methods of design. Camber

- steel floor members upward sufficient to compensate for the slab dead weight and any additional dead load the designers believe relevant.
- d. Structural steel members which are to receive sprayed fireproofing should not be painted prior to spraying, to insure adhesion of the fireproofing.
 - e. The design of steel-to-steel connections may be delegated to the fabricator's engineer. It is suggested that "Single Plate Connections" and "All-Bolted Double Angle Connections", as indicated in the AISC Steel Construction Manual, be considered for simple, typical connections.
 - f. Specify forces or a percentage of the "Maximum Total Uniform Load kips" table of the AISC Steel Construction Manual as the criteria for connection design.
 - g. Specify forces in braced steel frames to allow the fabricator's delegated engineer to design these connections.
 - h. The Engineer of Record shall design the base plates and anchor bolts for all columns.
2. Steel Joist Framing:
- a. Steel joists and joist girders shall be designed to resist gravity and wind uplift load effects indicated in the applicable Florida Building Code and ASCE-7 in compliance with high velocity wind zones (HVWZ) requirements..
 - b. Steel joists and joist girders shall be selected and specified from the Steel Joist Institutes publication entitled, "Standard Specifications and Load and Weight Tables for Steel joists and Joist Girders"
 - c. Roof joists subject to uplift loading shall have a line of bridging at the first bottom chord panel point.
 - d. Indicate on design drawings the net joist uplift so that the joist design professional may design the joists and joist girders to resist such loading.
3. Steel Decking:
- a. Steel decks shall be designed to comply with the requirements of the Steel Deck Institute (22-gauge deck thickness, minimum).
 - b. Provide as part of design documents pour stops, closures and other steel deck accessories, when necessary.
 - c. Steel floor decks shall be designed to resist gravity load effects as indicated in the Florida Building Code and ASCE-7 in compliance with high velocity wind zones (HVWZ) requirements..
 - d. The steel roof deck shall be designed to resist gravity and wind uplift load effects as indicated in the Florida Building Code and ASCE-7 in compliance with high velocity wind zones (HVWZ) requirements..
 - e. Exercise care in the spacing of supporting members near building edges so that roof deck can support the increased net uplift loading and so that fasteners have capacity to resist uplift and diaphragm forces concurrently.
 - f. The floor deck height and gauge shall be designed to support gravity loads and, also, so that it can span between supporting members, when acting as a form only for the weight of wet concrete plus construction loads, without shoring of the deck.

4. Cold-Formed Metal Framing:
 - a. Interior cold-formed metal vertical framing shall be designed to resist 5 psf lateral pressure, as per the Florida Building Code.
 - b. Exterior cold-formed metal framing shall be designed to resist lateral wind pressure as per Florida Building Code and ASCE-7 in compliance with high velocity wind zones (HVWZ) requirements.
 - c. Framing for the exterior soffits shall be designed for wind pressure per Florida Building Code and ASCE7 in compliance with high velocity wind zones (HVWZ) requirements. Provide vertical strut members to brace the soffit framing to the structure above. Struts shall be spaced on a 4'-0" by 4'-0" module.
 - d. Interior cold-formed metal horizontal framing shall be designed to resist gravity loads, per Florida Building Code.

5. Cold-Formed Metal Truss:
 - a. Trusses shall be designed to resist gravity loads specified in the Florida Building Code.
 - b. Trusses shall be designed to resist uplift forces per the Florida Building Code and ASCE7 in compliance with high velocity wind zones (HVWZ) requirements. .
 - c. The attachment of trusses to the building structure shall account for the simultaneous application of (1) uplift force, (2) horizontal wall parallel to trusses and (3) horizontal wall loads perpendicular to trusses.
 - e. Trusses shall be galvanized.

6. Metal Fabrications:
 - a. Safeguards and railings shall be designed for loads required by the Florida Building Code.
 - b. All aluminum used is to be copper free.
 - c. UMBS suggests that any metal components and accessories exposed to a maritime high-salinity environment shall be manufactured from aluminum. Use of stainless steel for this environment type is not permitted.
 - c. Copper finishes are not allowed.
 - d. Aluminum railings are to receive a UM preferred clear anodized finish as indicated.
 - e. UMBS suggests that any metal components and accessories exposed to a maritime high-salinity environment be manufactured from aluminum. Use of stainless steel is not permitted.

03.4 Specific requirements (organized by CSI MasterFormat® 2012 Numbers & Titles)

05 12 00	Structural Steel Framing
05 21 00	Steel Joist Framing
05 31 00	Steel Decking
05 40 00	Cold-Formed Metal Framing
05 44 00	Cold-Formed Metal Trusses
05 50 00	Metal Fabrication

05 12 00 Structural Steel Framing

Design Standards

1. Structural steel framing shall be designed as follows:
 - a. Performance requirements:
 - 1) Connections: Provide details of simple shear connections as required by the Contract Documents. These are to be selected or completed by the structural steel fabricator and designed to withstand loads indicated and to comply with all other information and restrictions indicated.
 - a) Select and complete connections using schematic details indicated on the contract documents and AISC 360.
 - b) Use LRFD; data are given at factored-load level or ASD; data are given at service-load level.
 - 2) Moment connections: Type PR, partially or FR, fully restrained.
 - b. LEED submittals:
 - 1) Product data for Credit MR 4.
 - 2) Laboratory Test Reports for Credit IEQ 4
 - c. Quality assurance parameters:
 - 1) Fabricator qualifications: Select a qualified fabricator who participates in the AISC Quality Certification Program and is designated an AISC - Certified Plant, Category STD.
 - 2) Installer qualifications: Select a qualified installer who participates in the AISC Quality Certification Program and is designated an AISC-Certified Erector, Category CSE.
 - 3) Welding qualifications: Qualify procedures and personnel according to AWS D1.1/D1.1M, "Structural Welding Code - Steel."
 - 4) Compliance with applicable provisions of the following specifications and documents:
 - a) AISC 303.

- b) AISC 360.
 - c) RCSC's "Specification for Structural Joints Using ASTM A 325 or A 490 Bolts."
- d. Structural steel products:
- 1) Structural steel materials as required:
 - a) Recycled content of steel products: Post-consumer recycled content plus one-half of pre-consumer recycled content not less than 50 percent.
 - b) W-Shapes: ASTM A992 or ASTM A572, Grade 50.
 - c) Channels, angles, M, S-shapes: ASTM A36 or ASTM A572, Grade 50.
 - d) Plate and bar: ASTM A36 or ASTM A572, Grade.
 - e) Cold-formed hollow structural sections: ASTM A500, Grade B or C, structural tubing.
 - f) Steel pipe: ASTM A53, Type E or S, Grade B.
 - g) Welding electrodes: Comply with AWS requirements
 - 2) Bolts, connectors and anchors as required:
 - a) High-Strength Bolts, Nuts, and Washers: ASTM A325 , Type 1, heavy-hex steel structural bolts; ASTM A 563, Grade C, heavy-hex carbon-steel nuts; and ASTM F 436 , Type 1, hardened carbon-steel washers; all with plain finish.
 - (1.) Direct-Tension Indicators: ASTM F959, Type 325, compressible-washer type with plain finish.
 - b) High-strength bolts, nuts, and washers: ASTM A490, Type 1, heavy-hex steel structural bolts or tension-control, bolt-nut-washer assemblies with splined ends; ASTM A563, Grade DH, heavy-hex carbon-steel nuts; and ASTM F436 , Type 1, hardened carbon-steel washers with plain finish.
 - (1.) Direct-tension indicators: ASTM F959, Type 490, Type 10.9, compressible-washer type with plain finish.
 - c) Zinc-coated high-strength bolts, nuts, and washers: ASTM A325, Type 1, heavy-hex steel structural bolts; ASTM A563, Grade DH heavy-hex carbon-steel nuts; and ASTM F436, Type 1, hardened carbon-steel washers.
 - (1.) Finish: Hot-dip zinc coating, mechanically deposited zinc coating, hot-dip or mechanically deposited zinc coating.
 - (2.) Direct-tension indicators: ASTM F959, Type 325, compressible-washer type with mechanically deposited zinc coating, mechanically deposited zinc coating or baked epoxy-coated finish.
 - d) Tension-control, high-strength bolt-nut-washer assemblies: ASTM F1852, Type 1 heavy-hex or round head assemblies consisting of steel structural bolts with splined ends, heavy-hex carbon-steel nuts, and hardened carbon-steel washers.
 - (1.) Finish: Plain or mechanically deposited zinc coating.

- e) Shear connectors: ASTM A108, Grades 1015 through 1020, headed-stud type, cold-finished carbon steel; AWS D1.1/D1.1M, Type B.
 - f) Un-headed anchor rods: ASTM F 1554, Grade 36 or ASTM F1554, Grade 55, weldable.
 - (1.) Configuration: Straight or hooked.
 - (2.) Finish: Plain, hot-dip zinc coating, ASTM A153, Class C or mechanically deposited zinc coating, ASTM B695, Class 50.
 - (3.) Headed anchor rods: ASTM F1554, Grade 36 or ASTM F1554, Grade 55, weldable, straight. Finish: Plain, hot-dip zinc coating, ASTM A153, Class C or Mechanically deposited zinc coating, ASTM B695, Class 50.
 - g) Threaded rods: ASTM A36 or ASTM A193, Grade B7.
 - (1.) Finish: Plain, hot-dip zinc coating, ASTM A153, Class C or Mechanically deposited zinc coating, ASTM B 695, Class 50.
 - h) Clevises and Turnbuckles: To be made from cold-finished carbon steel bars, ASTM A108, Grade 1035.
- 3) Primer requirements are as follows:
- a) Low-emitting materials: Paints and coatings shall comply with the testing and product requirements of the California Department of Health Services' "Standard Practice for the Testing of Volatile Organic Emissions from Various Sources Using Small-Scale Environmental Chambers".
 - b) Primer: SSPC-Paint 25, Type I or Type II, zinc oxide, alkyd, linseed oil primer.
 - c) Primer: Fabricator's standard lead- and chromate-free, non-asphaltic, rust-inhibiting primer complying with MPI#79 and compatible with topcoat.
- 4) Grout requirements are as follows:
- a) Metallic, shrinkage-resistant grout: ASTM C1107, factory-packaged, metallic aggregate grout, mixed with water to consistency suitable for application and a 30-minute working time.
 - b) Nonmetallic, shrinkage-resistant grout: ASTM C1107, factory-packaged, nonmetallic aggregate grout, noncorrosive and non-staining, mixed with water to consistency suitable for application and a 30-minute working time.
- 5) Fabrication requirements are as follows:
- a) Structural steel: Fabricate and assemble in shop to greatest extent possible. Fabricate according to AISC's "Code of Standard Practice for Steel Buildings and Bridges" and AISC 360.
 - b) Shear connectors: Prepare steel surfaces as recommended by manufacturer of shear connectors. Use automatic end welding of

headed-stud shear connectors according to AWS D1.1/D1.1M and manufacturer's written instructions.

- 6) Shop connection requirements as follows:
 - a) High-Strength Bolts: Shop install high-strength bolts according to RCSC's "Specification for Structural Joints Using ASTM A325 or A490 Bolts" for type of bolt and type of joint specified.
 - (1.) Joint Type: Snug tightened, pre-tensioned or slip critical.
 - b) Weld connections: Comply with AWS D1.1/D1.1M for tolerances, appearances, welding procedure specifications, weld quality, and methods used in correcting welding work.

- 7) Shop-priming requirements:
 - a) Shop-prime steel surfaces, except for the following:
 - (1.) For surfaces embedded in concrete or mortar, extend priming of partially embedded members to a depth of 2 inches.
 - (2.) Surfaces that are to be field welded.
 - (3.) Surfaces that are to be high-strength bolted with slip-critical connections.
 - (4.) Surfaces that are to receive sprayed fire-resistive materials (applied fireproofing).
 - (5.) Galvanized surfaces.
 - b) Surface Preparation: Clean surfaces to be painted. Remove loose rust and mill scale and spatter, slag, or flux deposits. Prepare surfaces according to the following specifications and standards:
 - (1.) SSPC-SP 2, "Hand Tool Cleaning".
 - (2.) SSPC-SP 3, "Power Tool Cleaning".
 - c) Priming: Immediately after surface preparation, apply primer according to manufacturer's written instructions and at rate recommended by SSPC to provide a minimum dry film thickness of 1.5 mils. Use priming methods that result in full coverage of joints, corners, edges, and exposed surfaces.

- 8) Source quality control requirements:
 - a) Testing agency: UM will engage an independent testing and inspecting agency to perform shop tests and inspections and prepare test reports.
 - (1.) Provide testing agency with access to places where structural-steel work is being fabricated or produced to perform tests and inspections.
 - b) Correct deficiencies in work that test reports and inspections indicate does not comply with the Contract Documents.
 - c) Bolted connections: Shop-bolted connections will be tested and inspected according to RCSC's "Specification for Structural Joints Using ASTM A 325 or A 490 Bolts".
 - d) Welded Connections: In addition to visual inspection, shop-welded connections will be tested and inspected according to

AWS D1.1/D1.1M and the following inspection procedures, at testing agency's option:

- (1.) Liquid penetrant inspection: ASTM E 165.
- (2.) Magnetic particle inspection: ASTM E 709; performed on root pass and on finished weld. Cracks or zones of incomplete fusion or penetration will not be accepted.
- (3.) Ultrasonic inspection: ASTM E 164.
- (4.) Radiographic inspection: ASTM E 94.

e. Execution of steel structural framing:

- 1) Erection requirements are as follows:
 - a) Set structural steel accurately in locations, to elevations indicated, and according to AISC 303 and AISC 360.
 - b) Base Bearing and Leveling Plates (as required): Clean concrete and masonry-bearing surfaces of bond-reducing materials, and roughen surfaces prior to setting plates. Clean bottom surface of plates.
 - (1.) Set plates for structural members on wedges, shims, or setting nuts, as required.
 - (2.) Weld plate washers to top of baseplate.
 - (3.) Snug-tighten or pretension anchor rods after supported members have been positioned and plumbed. Do not remove wedges or shims but, if protruding, cut off flush with edge of plate before packing with grout.
 - (4.) Promptly pack grout solidly between bearing surfaces and plates so that no voids remain. Neatly finish exposed surfaces, protect grout and allow curing. Comply with manufacturer's written installation instructions for shrinkage-resistant grouts.
 - c) Maintain erection tolerances of structural steel within AISC's "Code of Standard Practice for Steel Buildings and Bridges."
- 2) Field connections requirements as follows:
 - a) High-strength bolts: High-strength bolts are to comply with RCSC's "Specification for Structural Joints Using ASTM A325 or A 490 Bolts" for type of bolt and type of joint specified.
 - (1.) Joint Type: Snug tightened, pre-tensioned or slip-critical.
 - b) Weld Connections: Comply with AWS D1.1 and AWS D1.8 for tolerances, appearances, welding procedure specifications, weld quality, and methods used in correcting welding work.
 - (1.) Comply with AISC 303 and AISC 360 for bearing, alignment, adequacy of temporary connections, and removal of paint on surfaces adjacent to field welds.
- 3) Field quality control requirements:
 - a) Testing Agency: UM will engage a qualified independent testing and inspecting agency to inspect field welds and high-strength bolted connections.

- b) Bolted Connections: Bolted connections will be tested and inspected according to RCSC's "Specification for Structural Joints Using ASTM A 325 or A490 Bolts".
- c) Welded Connections: Field welds will be visually inspected according to AWS D1.1/D1.1M. In addition to visual inspection, field welds will be tested and inspected according to AWS D1.1/D1.1M and the following inspection procedures, at testing agency's option:
 - (1.) Liquid Penetrant Inspection: ASTM E 165.
 - (2.) Magnetic Particle Inspection: ASTM E 709; performed on root pass and on finished weld. Cracks or zones of incomplete fusion or penetration will not be accepted.
 - (3.) Ultrasonic Inspection: ASTM E 164.
 - (4.) Radiographic Inspection: ASTM E 94.
- d) Correct deficiencies in Work that test reports and inspections indicate does not comply with the Contract Documents.

05 21 00 Steel Joist Framing

Design Standards

1. Steel joist framing shall be designed as follows:
 - a. LEED submittals:
 - 1) Product data for Credit MR 4.
 - 2) Laboratory Test Reports for Credit IEQ 4
 - b. Steel joist framing submittals are to include:
 - 1) The layout, designation, number, type, location, and spacing of joists.
 - 2) Joining and anchorage details, bracing, bridging, and joist accessories; splice and connection locations and details; and attachments to other construction.
 - c. Manufacturer qualifications:
 - 1) Manufacturer Qualifications: A manufacturer certified by SJI to manufacture joists complying with the standard specifications and load tables in SJI's "Specifications".
 - d. Welding qualifications:
 - 1) Qualify field-welding procedures and personnel according to AWS D1.1/D1.1M, "Structural Welding Code – Steel".
 - e. Recycling requirements:
 - 1) Recycled Content of Steel Products: Post-consumer recycled content plus one-half of pre-consumer recycled content not less than 50 percent.
 - f. Steel joist requirements:
 - 1) K-series steel joists:
 - (a) Steel joists of type indicated shall be manufactured according to "Standard Specifications for Open Web Steel Joists, K-Series" in SJI's "Specifications", with steel-angle top- and bottom-chord members, underslung ends, and parallel top chord.

- (b) Steel Joist Substitutes shall be manufactured according to "Standard Specifications for Open Web Steel Joists, K-Series" in SJI's "Specifications", with steel-angle or -channel members.
- 2) Longspan steel joists:
 - (a) Longspan steel joists shall be manufactured according to "Standard Specifications for Longspan Steel Joists, LH-Series and Deep Longspan Steel Joists, DLH-Series" in SJI's "Specifications," with steel-angle top and bottom chord members; of joist type and end and top chord arrangements as indicated.
- 3) Joist girders:
 - (a) Joist girders shall be manufactured according to "Standard Specifications for Joist Girders" in SJI's "Specifications," with steel-angle top- and bottom-chord members; with end and top-chord arrangements as indicated.
- 4) Primers:
 - a) Low-emitting Materials: Paints and coatings shall comply with the testing and product requirements of the California Department of Health Services' "Standard Practice for the Testing of Volatile Organic Emissions from Various Sources Using Small - Scale Environmental Chambers".
 - (1.) Primer: SSPC-Paint 15, or manufacturer's standard shop primer complying with performance requirements in SSPC-Paint 15.
- 5) Joist accessories:
 - a) Bridging: Provide bridging anchors and number of rows of horizontal or diagonal bridging of material, size, and type required by SJI's "Specifications" for type of joist, chord size, spacing, and span. Furnish additional erection bridging as required for stability.
 - b) Schematically indicated bridging. Detail and fabricate according to SJI's "Specifications." Furnish additional erection bridging as required for stability.
 - c) Furnishing of ceiling extensions, either extended bottom chord elements or a separate extension unit of enough strength to construction. Extend ends to within 1/2 inch of finished wall surface unless otherwise indicated.
- 6) Carbon-steel bolts and threaded fasteners: ASTM A307, Grade A, carbon-steel, hex-head bolts and threaded fasteners; carbon-steel nuts; and flat, unhardened steel washers.
 - a) Finishes: Plain, uncoated, Hot-dip zinc coating, ASTM A153, Class C or Mechanically deposited zinc coating, ASTM B695, Class 50.
- 7) High-strength bolts, nuts, and washers: ASTM A325, Type 1, heavy hex steel structural bolts; ASTM A563 heavy hex carbon-steel nuts; and ASTM F436 hardened carbon-steel washers.
 - a) Finishes: Plain, Hot-dip zinc coating, ASTM A153, Class C or mechanically deposited zinc coating, ASTM B695, Class 50.
- 8) Furnishing of miscellaneous accessories including splice plates and bolts required by joist manufacturer to complete joist assembly.

- g. Cleaning and shop painting:
 - 1) Cleaning and removal of loose scale, heavy rust, and other foreign materials from fabricated joists and accessories and the application of one coat of shop primer.

- h. Installation of steel joists:
 - 1) Joists shall not be installed until supporting construction is in place and secured.
 - 2) Joists and accessories shall be installed plumb, square, and true to line; securely fasten to supporting construction according to SJI's "Specifications", joist manufacturer's written recommendations, and requirements in this Section as follow:
 - a) Before installation, splice joists delivered to Project site in more than one piece.
 - b) Space, adjust, and align joists accurately in location before permanently fastening.
 - c) Install temporary bracing and erection bridging, connections, and anchors to ensure that joists are stabilized during construction.
 - 3) Field welding of joists to supporting steel bearing plates and/or framework. Coordinate welding sequence and procedure with placement of joists. Comply with AWS requirements and procedures for welding, appearance and quality of welds, and methods used in correcting welding work.
 - (4) Bolting of joists to supporting steel framework using carbon-steel bolts as required.
 - 5) Bolting of joists to supporting steel framework using high-strength structural bolts. Comply with Research Council on Structural Connection's "Specification for Structural Joints Using ASTM A325 or ASTM A490 Bolts" for high-strength structural bolt installation and tightening requirements.
 - 6) The installation and connecting of bridging shall be done concurrently with joist erection, before construction loads are applied. Anchor ends of bridging lines at top and bottom chords if terminating at walls or beams.

- i. Field quality control requirements:
 - 1) UM will engage a qualified independent testing and inspecting agency to inspect field welds and bolted connections and to perform field tests and inspections and prepare test and inspection reports.

05 31 00 Steel Decking

Design Standards

- 1. The Design Professional shall design the steel decking as follows:
 - a. LEED submittals:
 - 1) Product data for Credit MR 4.
 - 2) Laboratory Test Reports for Credit IEQ 4.

- b. Steel decking submittals:
 - 1) Include layout and types of deck panels, anchorage details, reinforcing channels, pans, cut deck openings, special jointing, accessories, and attachments to other construction.
- c. Quality assurance requirements:
 - 1) Testing agency qualifications: Qualified according to ASTM E329 for testing indicated.
 - 2) Welding qualifications: Qualify procedures and personnel according to AWS D1.3, "Structural Welding Code - Sheet Steel".
- d. Performance requirements:
 - 1) Design to be based upon AISI Specifications: Complying with calculated structural characteristics of steel deck according to AISI's "North American Specification for the Design of Cold-Formed Steel Structural Members".
- e. Recycling requirements:
 - 1) Recycled Content of Steel Products: Post-consumer recycled content plus one-half of pre-consumer recycled content not less than 25 percent.
- f. Low-emitting paint and coatings as follows:
 - 1) Paints and coatings shall comply with the testing and product requirements of the California Department of Health Services' "Standard Practice for the Testing of Volatile Organic Emissions from Various Sources Using Small-Scale Environmental Chambers."
- g. Steel decking as follows:
 - 1) Roof decking as follows:
 - a) Fabrication of panels, without top-flange stiffening grooves, to comply with "SDI Specifications and Commentary for Steel Roof Deck," in SDI Publication No. 31, and with the following:
 - (1.) Prime-Painted Steel Sheet: ASTM A1008, Structural Steel Grade 33, Grade 40 or Grade 80 minimum, shop primed with manufacturer's standard baked-on, rust-inhibitive primer (color as required).
 - (2.) Galvanized-steel sheet: ASTM A653, Structural Steel, Grade 33, Grade 40 or Grade 80, G60 or G90 zinc coating.
 - (3.) Galvanized and Shop-Primed Steel Sheet: ASTM A653, Structural Steel, Grade 33, Grade 40 or Grade 80, G60 zinc coating; cleaned, pretreated, and primed with manufacturer's standard baked-on, rust-inhibitive primer (color as required).
 - (4.) Deck profile shall be specified as necessary.
 - (5.) Profile depth shall be specified as necessary.
 - (6.) Uncoated steel thickness is to be designed and specified.

- 2) Composite floor decking as follows:
 - a) Fabrication of panels, with integrally embossed or raised pattern ribs and interlocking side laps, to comply with "SDI Specifications and Commentary for Composite Steel Floor Deck," in SDI Publication No. 31, with the minimum section properties indicated, and with the following:
 - (1.) Prime-Painted Steel Sheet: ASTM A 1008, Structural Steel Grade 33, Grade 40 or Grade 80 minimum, with top surface phosphatized and unpainted, and underside surface shop primed with manufacturers' standard gray or white baked-on, rust-inhibitive primer.
 - (2.) Galvanized-Steel Sheet: ASTM A653, Structural Steel, Grade 33 or G30, G60 or G90 zinc coating.
 - (3.) Galvanized and Shop-Primed Steel Sheet: ASTM A 653/, Structural Steel, Grade 33, G30 or G60 zinc coating; with unpainted top surface and cleaned, and pretreated bottom surface primed with manufacturer's standard gray or white baked-on, rust-inhibitive primer.
 - (4.) Profile depth is to be specified.
 - (5.) Uncoated steel thickness is to be designed and specified.
- 3) Non-composite form deck as follows:
 - a) Fabrication of ribbed-steel-sheet non-composite form-deck panels to comply with "SDI Specifications and Commentary for Non-composite Steel Form Deck," in SDI Publication No. 31, with the minimum section properties indicated, and with the following:
 - (1.) Uncoated Steel Sheet: ASTM A1008, Structural Steel Grade 33, Grade 40 or Grade 80 minimum.
 - (2.) Prime-Painted Steel Sheet: ASTM A 1008, Structural Steel Grade 33, Grade 40 or Grade 80 minimum, with top and underside surface shop primed with manufacturer's standard baked-on, rust-inhibitive primer (color as required).
 - (3.) Galvanized-Steel Sheet: ASTM A653, Structural Steel Grade 33, Grade 40 or Grade 80, G30, G60 or G90 zinc coating.
 - (4.) Galvanized and Shop-Primed Steel Sheet: ASTM A 653, Structural Steel Grade 33 or Grade 80, G60 zinc coating; cleaned, pretreated, and primed with manufacturer's standard baked-on, rust-inhibitive primer (color as required).
 - (5.) Profile depth is to be specified.
 - (6.) Uncoated steel thickness is to be designed and specified.
- 4) Accessories as follows:
 - a) Provide manufacturer's standard accessory materials for deck that comply with requirements indicated.

- h. Installation of steel decking as follows:
 - 1) Install deck panels and accessories according to applicable specifications and commentary in SDI Publication No. 31, as per manufacturer's written instructions, and requirements in this Section.
- i. Field quality control requirements:
 - 1) Testing Agency: UM will engage a qualified testing agency to perform tests and inspections.
 - 2) Field welds shall be subject to inspection.
 - 3) The testing agency's written report shall be transmitted promptly Contractor and Design Professional.
 - 4) Removal and replacement work shall be specified where the test results indicate non-compliance with the specified requirements.
 - 5) Additional testing and inspections shall be performed to determine the replacement and additional work's compliance with the specified requirements, at Contractor's expense.
- j. Protection of completed work.
 - 1) Galvanizing repairs: Prepare and repair damaged galvanized coatings on both surfaces of deck with galvanized repair paint according to ASTM A780 and manufacturer's written instructions.
 - 2) Painting repairs: Wire brush and clean rust spots, welds, and abraded areas on both surfaces or on top surface of prime-painted deck immediately after installation, and apply repair paint.

05 40 00 Cold-Formed Metal Framing

Design Standards

- 1. The Design Professional shall design the cold-formed metal framing as follows:
 - a. LEED submittals:
 - 1) Product data for Credit MR 4.
 - b. Cold-formed metal framing submittals:
 - 1) Include layout, spacing, sizes, thicknesses, and types of cold-formed steel framing; fabrication; and fastening and anchorage details, including mechanical fasteners.
 - 2) Indicate reinforcing channels, opening framing, supplemental framing, strapping, bracing, bridging, splices, accessories, connection details, and attachment to adjoining work.
 - c. Quality assurance requirements:
 - 1) Specify product tests: Mill certificates or data from a qualified independent testing agency.

- 2) Specify qualifications for welding: Qualify procedures and personnel according to AWS D1.3/D1.3M, "Structural Welding Code - Sheet Steel."
 - 3) Specify compliance with AISI S230 "Standard for Cold-Formed Steel Framing - Prescriptive Method for One and Two Family Dwellings", if required.
- d. Performance requirements:
- 1) Unless more stringent requirements are indicated, specify compliance with AISI S100 and AISI S200.
 - 2) Fire-resistance ratings shall comply with ASTM E119. Testing to be by UM testing agency.
 - 3) Design designations from UL's "Fire Resistance Directory" or from the listings of another qualified testing agency.
 - 4) Recycle content of steel products as follows:
 - a) Post-consumer recycled content plus one-half of pre-consumer recycled content not less than 25 percent.
- e. Cold-formed metal framing requirements:
- 1) General requirements for cold-formed metal framing as follows:
 - a) Steel sheet to comply with steel sheet: ASTM A1003, structural grade, Type H, metallic coated, of grade and coating weight as follows:
 - (1.) Grade: ST33H, ST50H, or as required by structural performance
 - (2.) Coating: G60, A60, AZ50, GF30, G90 or equivalent.
 - b) Steel sheet for vertical deflection or drift clips: ASTM A653, structural steel, zinc coated, of grade and coating as follows:
 - (1.) Grade: 33, 50, Class 1 or as required by structural performance.
 - (2.) Coating: G60 or G90.
 - 2) Load-bearing wall framing requirements:
 - a) Steel studs: Manufacturer's standard C-shaped steel studs, of web depths indicated, punched, with stiffened flanges, and as follows:
 - (1.) Specify minimum base metal thickness.
 - (2.) Specify flange width.
 - (3.) Specify section properties such as minimum allowable calculated section modulus, moment of inertia, and allowable moment.
 - b) Steel track as follows: Manufacturer's standard U-shaped steel track, of web depths indicated, un-punched, with straight flanges, and matching minimum base-metal thickness of steel studs.
 - c) Steel box or back-to-back headers: Manufacturer's standard C-shapes used to form header beams, of web depths indicated, un-punched, with stiffened flanges, and as follows:
 - (1.) Specify minimum base metal thickness.

- (2.) Specify flange width.
 - (3.) Specify section properties such as minimum allowable calculated section modulus, moment of inertia, and allowable moment.
- 3) Exterior non-load-bearing wall framing requirements:
- a) Steel studs: Manufacturer's standard C-shaped steel studs, of web depths indicated, punched, with stiffened flanges, and as follows:
 - (1.) Specify minimum base metal thickness.
 - (2.) Specify flange width.
 - (3.) Specify section properties such as minimum allowable calculated section modulus, moment of inertia, and allowable moment.
 - b) Steel track: Manufacturer's standard U-shaped steel track, of web depths indicated, un-punched, with un-stiffened flanges, and matching minimum base-metal thickness of steel studs.
 - c) Vertical deflection clips: Manufacturer's standard bypass or head clips, capable of accommodating upward and downward vertical displacement of primary Structure through positive mechanical attachment to stud web.
 - d) Single deflection track if required: Manufacturer's single, deep-leg, U-shaped steel track; un-punched, with un-stiffened flanges, of web depth to contain studs while allowing free vertical movement, with flanges designed to support horizontal loads and transfer them to the primary structure.
 - e) Double deflection tracks if required: Manufacturer's double, deep-leg, U-shaped steel tracks, consisting of nested inner and outer tracks; un-punched, with un-stiffened flanges.
 - f) Drift clips if required: Manufacturer's standard bypass or head clips, capable of isolating wall stud from upward and downward vertical displacement and lateral drift of primary structure through positive mechanical attachment to stud web and structure.
- 4) Framing accessories as follows:
- a) Specify the fabrication of the steel-framing accessories from steel sheet, ASTM A 1003, structural grade, Type H, metallic coated, of same grade and coating weight used for framing members.
 - b) Specify that accessories be provided with manufacturer's standard thickness and configuration.
- 5) Anchors, clips and fasteners when required:
- a) Steel shapes and clips: ASTM A36, zinc coated by hot-dip process according to ASTM A123.
 - b) Anchor bolts: ASTM F1554, Grade 36 or Grade 55, threaded carbon-steel, hex-headed bolts, headless hooked bolts or headless bolts with encased end threaded, and carbon-steel nuts; and flat, hardened-steel washers; zinc coated by hot-dip process

- according to ASTM A153, Class C or mechanical deposition according to ASTM B695, Class 50.
- c) Expansion anchors: Fabricated from corrosion-resistant materials, with allowable load or strength design capacities calculated according to ICC-ES AC193 and ACI 318 greater than or equal to the design load, as determined by testing per ASTM E488 conducted by a qualified testing agency.
 - d) Power-actuated anchors: Fastener system of type suitable for application indicated, fabricated from corrosion-resistant materials, with allowable load capacities calculated according to ICC-ES AC70, greater than or equal to the design load, as determined by testing per ASTM E1190 conducted by a qualified testing agency.
 - e) Mechanical fasteners: ASTM C1513, corrosion-resistant-coated, self-drilling, self-tapping, steel drill screws.
 - (1.) Head Type: Low-profile head beneath sheathing, manufacturer's standard elsewhere.
- 6) Miscellaneous materials as follows:
- a) Galvanizing repair paint: SSPC-Paint 20 or MIL-P- 21035B, ASTM A780.
 - b) Cement grout: Portland cement, ASTM C150, Type I; and clean, natural sand, ASTM C404.
 - c) Non-metallic, non-shrink grout: Premixed, nonmetallic, noncorrosive, non-staining grout containing selected silica sands, Portland cement, shrinkage-compensating agents, and plasticizing and water-reducing agents, complying with ASTM C1107, with fluid consistency and 30-minute working time.
 - d) Shims: Load bearing, high-density multimonomer plastic, and non-leaching; or of cold-formed steel of same grade and coating as framing members supported by shims.
 - e) Sealer gaskets: Closed-cell neoprene foam, selected from manufacturer's standard widths to match width of bottom track or rim track members.
- f. Cold-formed metal framing installation:
- 1) Install load bearing shims or grout between the underside of the load-bearing wall's bottom track and the top of foundation wall or slab, when necessary, to ensure a uniform bearing surface supporting concrete or masonry construction.
 - 2) Install sealer gaskets at the underside of wall bottom track or rim track and at the top of foundation wall or slab at stud or joist locations, as required.
 - 3) Cold-formed steel framing may be either shop or field fabricated for installation, or field assembled.
 - 4) Install cold-formed steel framing according to SI S200 and the manufacturer's written instructions, except where more stringent requirements are indicated.
 - 5) Install temporary bracing as necessary.

- 6) Install insulation as required.
 - 7) Erection tolerances.
 - 8) Install load-bearing walls as required.
 - 9) Install non-load-bearing walls as required.
- g. Field quality control requirements:
- 1) Testing: UM will engage a qualified independent testing and inspecting agency to perform field tests and inspections and prepare test reports.
 - 2) Field and shop welds will be subject to testing and inspections.
 - 3) The testing agency's written report shall be transmitted promptly Contractor and Design Professional.
 - 4) Removal and replacement work shall be specified where the test results indicate non-compliance with the specified requirements.
 - 5) Additional testing and inspections shall be performed to determine the replacement and additional work's compliance with the specified requirements, at Contractor's expense.
- h. Protection of completed work.
- 1) Galvanizing repairs: Prepare and repair damaged galvanized coatings on fabricated and installed cold-formed steel framing with galvanized repair paint according to ASTM A 780 and manufacturer's written instructions.
 - 2) Final protection and maintenance of conditions shall be provided in a manner acceptable to the manufacturer and installer, that insures that the cold-formed steel framing is without damage or deterioration at time of substantial completion.

05 44 00 Cold-Formed Metal Trusses

Design Standards

1. The Design Professional shall design the cold-formed metal trusses as follows:
 - a. LEED submittals:
 - 1) Product data for Credit MR 4.
 - b. Cold-formed metal trusses submittals:
 - 1) Include layout, spacing, sizes, thicknesses, and types of cold-formed steel trusses; fabrication; and fastening and anchorage details, including mechanical fasteners.
 - 2) Indicate reinforcing channels, opening framing, supplemental framing, strapping, bracing, bridging, splices, accessories, connection details, and attachment to adjoining work.
 - 3) Delegated-Design Submittal: For cold-formed steel trusses.
 - c. Quality assurance requirements as follows:
 - 1) Testing Agency Qualifications: Qualified according to ASTM E329 for testing indicated.
 - 2) Product Tests: Provide mill certificates or data from a qualified testing agency indicating steel sheet complies with requirements, including base-

- metal thickness, yield strength, tensile strength, total elongation, chemical requirements, and metallic-coating thickness.
- 3) Welding Qualifications: Qualify procedures and personnel according to the following:
 - a) AWS D1.1/D1.1M, "Structural Welding Code - Steel".
 - b) AWS D1.3/D1.3M, "Structural Welding Code - Sheet Steel".

 - d. Specify performance requirements if required as follows:
 - 1) If a delegated design is required: Engage a qualified professional engineer to design cold-formed steel framing.
 - 2) Structural performance: Provide cold-formed steel trusses capable of withstanding design loads within limits and under conditions indicated:
 - a) Design loads: As indicated.
 - b) Deflection limits: Design trusses to withstand design loads without deflections greater than the following:
 - (1.) Floor trusses: Specify vertical deflection for total loads of the span.
 - (2.) Roof trusses: Specify vertical deflection of the span.
 - (3.) Scissor roof trusses: Specify horizontal deflection at reactions.
 - 3) Design the framing systems to provide for movement of framing members located outside the insulated building envelope without damage or overstressing, sheathing failure, connection failure, undue strain on fasteners and anchors, or other detrimental effects when subject to a maximum ambient temperature change of 120 degrees F.

 - e. Cold-formed steel framing design standards:
 - 1) Floor and roof systems: Design according to AISI S210.
 - 2) Lateral design: Design according to AISI S213.
 - 3) Roof trusses: Design according to AISI S214.
 - 4) Fire-resistance ratings: Comply with ASTM E119; testing by a qualified testing agency. Identify products with appropriate markings from an applicable testing agency.

 - f. Cold-formed steel truss materials as follows:
 - 1) Recycled content of steel products: Post-consumer recycled content plus one-half of pre-consumer recycled content not less than 25 percent.
 - 2) Steel sheet: ASTM A1003, structural grade, Type H, metallic coated, of grade and coating weight as follows:
 - a) Grade as required by structural performance.
 - b) Coating: G60, A60, AZ50, or GF30 or equivalent.

 - g. Roof truss members: Manufacturer's standard steel sections or as required.
 - 1) Connecting flange width: Specify minimum at top and bottom chords connecting to sheathing or other directly fastened construction.
 - 2) Minimum base-metal thickness.

- 3) Section properties: Minimum allowable calculated section modulus, moment of inertia, and allowable moment.
- h. Floor truss members: Manufacturer's standard steel sections or as required.
- 1) Connecting flange width: Specify minimum at top and bottom chords connecting to sheathing or other directly fastened construction.
 - 2) Minimum base-metal thickness.
 - 3) Section properties: Minimum allowable calculated section modulus, moment of inertia, and allowable moment.
- i. Accessories:
- 1) Fabricate steel-framing accessories from steel sheet, ASTM A1003, structural grade, Type H, metallic coated, of same grade and coating weight used for truss members.
 - 2) Provide accessories of manufacturer's standard thickness and configuration unless otherwise indicated.
- j. Anchors, clips and fasteners when required:
- 1) Steel shapes and clips: ASTM A36, zinc coated by hot-dip process according to ASTM A123.
 - 2) Anchor bolts: ASTM F1554, Grade 36 or Grade 55, threaded carbon-steel, hex-headed bolts, headless hooked bolts or headless bolts with encased end threaded, and carbon-steel nuts; and flat, hardened-steel washers; zinc coated by hot-dip process according to ASTM A153, Class C or mechanical deposition according to ASTM B695, Class 50.
 - 3) Expansion anchors: Fabricated from corrosion-resistant materials, with allowable load or strength design capacities calculated according to ICC-ES AC193 and ACI 318 greater than or equal to the design load, as determined by testing per ASTM E488 conducted by a qualified testing agency.
 - 4) Power-actuated anchors: Fastener system of type suitable for application indicated, fabricated from corrosion-resistant materials, with allowable load capacities calculated according to ICC-ES AC70, greater than or equal to the design load, as determined by testing per ASTM E1190 conducted by a qualified testing agency.
 - 5) Mechanical fasteners: ASTM C1513, corrosion-resistant-coated, self-drilling, self-tapping, steel drill screws.
 - (a) Head Type: Low-profile head beneath sheathing, manufacturer's standard elsewhere.
- k. Miscellaneous materials:
- 1) Galvanizing repair paint: SSPC-Paint 20 or MIL-P-21035B or ASTM A780.
 - 2) Shims: Load bearing, of high-density multi-monomer plastic, non-leaching; or of cold-formed steel of same grade and coating as framing members supported by shims.

- I. Fabrication:
 - 1) Fabrication of cold-formed steel trusses and accessories according to referenced AISI's specifications and standards, and/or manufacturer's written instructions.
 - 2) Fastening of cold-formed steel truss members as required.
 - a) Comply with AWS D1.3/D1.3M requirements and procedures for welding, appearance and quality of welds, and methods used in correcting welding work.
 - 3) Fastening of other materials to cold-formed steel trusses by welding, bolting, pneumatic pin fastening, or screw fastening as required.
 - 4) Fabrication tolerances:

- m. Execution requirements:
 - 1) Fire resistive materials installation as follows:
 - a) Before sprayed fire-resistive materials are applied, attach continuous angles, supplementary framing, or tracks to structural members indicated to receive sprayed fire-resistive materials.
 - b) After applying sprayed fire-resistive materials, remove only as much of these materials as needed to complete installation of cold-formed steel trusses without reducing thickness of fire-resistive materials. Protect remaining fire-resistive materials from damage.
 - 2) Installation:
 - a) Install bridging and bracing of cold-formed steel trusses according to AISI S200, AISI S214, AISI's "Code of Standard Practice for Cold-Formed Steel Structural Framing," and the manufacturer's written instructions unless requirements that are more stringent are indicated.
 - b) The installation of cold-formed steel trusses and accessories shall be plumb, square, and true to line, and with connections securely fastened.
 - c) Cold-formed steel trusses shall be fastened by welding or mechanical fasteners complying with AWS D1.3/D1.3M requirements and procedures for welding, appearance and quality of welds, and methods used in correcting welding work.
 - d) Install temporary bracing and supports.
 - e) Truss Spacing.
 - f) The installation of continuous bridging and permanently braced trusses shall be designed according to CFSEI's Tech Note 551e, "Design Guide: Permanent Bracing of Cold-Formed Steel Trusses".
 - g) Erection tolerances.

- n. Field quality control requirements:
 - 1) Special Inspections: UM will engage a qualified special inspector to perform inspections.

 - 2) Testing Agency: UM will engage a qualified testing agency to perform tests and inspections.

- 3) Field and shop welds will be subject to testing and inspections.
 - 4) UM's special testing inspector and testing agency shall prepare test and inspection reports.
- o. Repairs and protection of completed works:
- 1) Galvanizing repairs: Prepare and repair damaged galvanized coatings on fabricated and installed cold-formed metal framing with galvanized repair paint according to ASTM A780 and manufacturer's written instructions.
 - 2) Final protection and maintenance conditions, in a manner acceptable to the manufacturer and installer, to insure that cold-formed metal trusses are without damage or deterioration at time of substantial completion.

05 50 00 Metal Fabrication

Design Standards

1. The Design Professional shall design the metal fabrication as follows:
 - a. LEED submittals:
 - 1) Product data for Credit MR 4.
 - 2) Laboratory Test Reports for Credit IEQ 4
 - b. Performance requirements:
 - 1) Should a delegated design be required, engage a qualified professional engineer to design the aluminum ladders.
 - 2) Structural performance of aluminum ladders and structural components: Aluminum ladders and accessories including landings, shall withstand the effects of loads and stresses within limits and under conditions specified in ANSI A14.3.
 - 3) Specify an allowance for thermal movements from ambient and surface temperature changes acting on exterior metal fabrications by preventing buckling, opening of joints, overstressing of components, failure of connections, and other detrimental effects.
 - a) Temperature Change: 120 degrees F, ambient; 180 degrees F, material surfaces.
 - c. Submittals as follows:
 - 1) Fabrication and installation details for metal fabrications.
 - a) Include plans, elevations, sections, and details of metal fabrications and their connections. Show anchorage and accessory items.
 - 2) Samples for each type and finish of extruded nosing and tread.
 - 3) Delegated-Design Submittal: For installed products indicated to comply with performance requirements and design criteria, including analysis data signed and sealed by the qualified professional engineer responsible for their preparation.

- d. Product requirements:
- 1) Materials and surfaces as follows:
 - a) Provide materials with smooth, flat surfaces without blemishes.
 - 2) Ferrous metals:
 - a) Recycled content of steel products: Post-consumer recycled content plus one-half of pre-consumer recycled content not less than 25 percent.
 - b) Steel plates, shapes, and bars: ASTM A36.
 - c) Stainless-steel bars and shapes: ASTM A276, Type 304 or Type 316L.
 - d) Rolled-steel floor plate: ASTM A786, rolled from plate complying with ASTM A36 or ASTM A283, Grade C or D.
 - e) Rolled-stainless-steel floor plate: ASTM A793.
 - f) Steel tubing: ASTM A500, cold-formed steel tubing.
 - g) Steel pipe: ASTM A53, standard weight (Schedule 40) unless otherwise indicated.
 - h) Slotted channel framing: Cold-formed metal box channels struts complying with MFMA-4.
 - (1.) Specify size of channels.
 - (2.) Specify materials:

Galvanized steel, ASTM A653, commercial steel, Type B or structural steel, Grade 33, with G90 coating; specify nominal thickness.

Cold-rolled steel, ASTM A1008 commercial steel, Type B or structural steel, Grade 33. Specify minimum thickness; unfinished or coated with rust-inhibitive, baked-on, acrylic enamel or hot-dip galvanized after fabrication.
 - i) Cast iron: Either gray iron, ASTM A48, or malleable iron, ASTM A47.
 - 3) Non-ferrous metals:
 - a) Aluminum extrusions: ASTM B221, Alloy 6063-T6.
 - b) Aluminum-alloy rolled tread plate: ASTM B632, Alloy 6061-T6.
 - c) Aluminum castings: ASTM B26, Alloy 443.0-F.
 - d) Bronze extrusions: ASTM B455, Alloy UNS No. C38500 (extruded architectural bronze).
 - e) Bronze castings: ASTM B584, Alloy UNS No. C83600 (leaded red brass) or No. C84400 (leaded semi red brass).
 - f) Nickel Silver Castings: ASTM B584, Alloy UNS No. C97600 (20 percent leaded nickel bronze).
 - 4) Aluminum Exterior Finishes:
 - a) Material for exterior locations shall be manufactured from aluminum as indicated: The UM preferred metal finish shall be a clear anodic finish as indicated by a AAMA 611, AA-M12C22A41, Class I, 0.018 mm or thicker coat. The use of a high performance organic finish with a minimum two-coat fluoropolymer finish for non-metallic colors and a

three-to four coat finish per manufacturers recommendations complying with AAMA 2605 and containing not less than 70 percent PVDF resin by weight in color coat can also be used but only with prior approval by the UMBS Committee.

b) UMBS suggests that any exterior metal components and accessories exposed to a maritime high-salinity environment be manufactured from aluminum material. Use of stainless steel metal fabrications and accessories will only be permitted with approval by the UMBS Committee.

- 5) Fasteners:
 - a) Specify if required Type 304 or Type 316 stainless-steel fasteners for exterior use and zinc-plated fasteners with coating complying with ASTM B633 or ASTM F1941, Class Fe/Zn 5, at exterior walls.
 - (1.) Provide stainless-steel fasteners for fastening aluminum.
 - (2.) Provide stainless-steel fasteners for fastening stainless steel.
 - (3.) Provide stainless-steel fasteners for fastening nickel silver.
 - (4.) Provide bronze fasteners for fastening bronze.
- 6) Cast-in-place anchors in concrete: Either threaded type or wedge type unless otherwise indicated; galvanized ferrous castings, either ASTM A47 malleable iron or ASTM A27 cast steel. Provide bolts, washers, and shims as needed, all hot-dip galvanized per ASTM F2329.
- 7) Post-installed anchors: Torque-controlled expansion anchors or chemical anchors.
 - a) Material for interior locations: Carbon-steel components zinc plated to comply with ASTM B633 or ASTM F1941 Class Fe/Zn 5, unless otherwise indicated.
 - b) Material for exterior locations and where stainless steel is indicated: Alloy Group 1 or Group 2 stainless-steel bolts, ASTM F593, and nuts, ASTM F594.
 - c) Material for exterior locations and where aluminum is indicated: use Kynar 500 (or similar) factory applied coating as a standard finish with approval by the UMBS Committee.
- 8) Slotted-channel inserts: Cold-formed, hot-dip galvanized-steel box channels (struts) complying with MFMA-4, indicated with anchor straps or studs. Provide with temporary filler and tee-head bolts, complete with washers and nuts, all zinc-plated to comply with ASTM B633, Class Fe/Zn 5, as needed for fastening to inserts.
- 9) Miscellaneous materials as follows:
 - a) Low-Emitting Materials: Paints and coatings shall comply with the testing and product requirements of the California Department of Health Services' "Standard Practice for the Testing of Volatile

- Organic Emissions from Various Sources Using Small-Scale Environmental Chambers."
- b) Specify shop primers, universal shop primer and epoxy zinc-rich primer.
 - c) Specify galvanizing repair paint, bituminous paint and non-shrink, non-metallic grout: Factory-packaged.
- 10) Fabrication:
- a) Shop Assembly: Preassemble items in the shop to greatest extent possible. Use connections that maintain structural value of joined pieces.
- 11) Miscellaneous framing and support:
- a) Specify steel framing and supports not specified in other sections and as needed to complete the work. Specify the fabrication of the units from steel shapes, plates, and bars of welded construction unless otherwise indicated.
- 12) Pre-fabricated building columns as necessary:
- a) Prefabricated building columns shall consist of load-bearing structural-steel members protected by concrete fireproofing and encased in an outer non-load-bearing steel shell. Specify the fabrication of connections to comply with details shown or as needed to suit type of structure indicated.
 - (1.) Fire-resistance rating of prefabricated building columns to be listed and labeled by a testing and inspecting agency acceptable to authorities having jurisdiction for ratings indicated, based on testing according to ASTM E119. Fire-Resistance Rating: As indicated.
- 13) Shelf angles as required:
- a) Fabrication of shelf angles from steel angles of sizes indicated and for attachment to concrete framing.
- 14) Metal ladders:
- a) Specify as follows:
 - (1.) Comply with ANSI A14.3 unless otherwise indicated.
 - (2.) For elevator pit ladders, comply with ASME A17.1.
 - b) Steel ladders:
 - (1.) Specify side rails' spacing, material and finishes.
 - (2.) Specify rung spacing, materials and finishes.
 - c) Aluminum ladders:
 - (1.) Specify side rails' spacing.
 - (2.) Specify rung spacing, materials and finishes.
 - d) Ladder safety cages as follows:
 - (1.) Specify fabrication of ladder safety cages to comply with ANSI A14.3. Assembly shall be by welding or with

- stainless-steel fasteners and include galvanizing the steel, including brackets and fasteners.
- (2.) Specify location and spacing of primary hoops and secondary intermediate hoops.
- 15) Metal floor plate if required:
- Fabrication shall be from rolled-steel floor, rolled-stainless-steel floor, rolled-aluminum-alloy tread or abrasive-surface floor plate.
 - Specify plate thickness.
 - Specify angle supports.
 - Specify flush bar drop handles for lifting removable sections, one at each end of each section.
- 16) Structural-steel door frames if required:
- Fabricate structural-steel door frames from steel shapes fully welded together, with steel channel stops. Plug-weld built-up members and continuously weld-exposed joints. Reinforce frames and drill and tap as necessary to accept finish hardware. Specify integrally welded steel strap anchors for securing door frames into adjoining concrete or masonry.
- 17) Metal nosing, treads, and threshold as follows:
- Specify cast metal units as required.
 - Specify extruded units as required.
- 18) Specify the following when necessary:
- Loose bearing and leveling plates.
 - Loose steel lintels.
 - Steel welded plates and angles.
 - Metal bollards.
 - Miscellaneous steel trims.
- 19) Steel and iron finishes:
- Galvanizing: Hot-dip galvanize items as indicated to comply with ASTM A153 for steel and iron hardware and with ASTM A123 for other steel and iron products.
 - Shop prime iron and steel items not indicated to be galvanized unless they are to be embedded in concrete, sprayed-on fireproofing, or masonry, or unless otherwise indicated.
 - Shop prime with universal shop primer as required.
- e. Execution of metal fabrication:
- General installation:
 - Cutting, Fitting and Placement: Perform cutting, drilling, and fitting required for the installation of metal fabrications. Set metal fabrications accurately in location, alignment, and elevation; with

- edges and surfaces level, plumb, true, and free of rack; and measured from established lines and levels.
- b) Fit exposed connections accurately together to form hairline joints. Weld connections that are not to be left as exposed joints but cannot be shop welded because of shipping size limitations. Do not weld, cut or abrade surfaces of exterior units that have been hot-dip galvanized after fabrication and are for bolted or screwed field connections.
 - (l) Specify field welding requirements.
 - 2) Fastening to In-Place Construction: Anchorage devices and fasteners where metal fabrications are required to be fastened to in-place construction.
 - 3) Corrosion Protection: Coat concealed surfaces of aluminum that come into contact with grout, concrete, masonry or wood, or dissimilar metals with the following:
 - a) Cast aluminum: Heavy coat of bituminous paint
 - b) Extruded aluminum: Two coats of clear lacquer
- f. Adjusting and Cleaning:
- 1) Touchup painting: Immediately after erection, clean field welds, bolted connections, and abraded areas. Paint uncoated and abraded areas with the same material as used for shop painting to comply with SSPC-PA 1 for touching up shop-painted surfaces.
 - 2) Galvanized surfaces: Clean field welds, bolted connections, and abraded areas and repair galvanizing to comply with ASTM A780.

DIVISION 06 WOOD, PLASTICS, AND COMPOSITES

This chapter identifies criteria for the design of Interior Architectural Woodwork and the general requirements for rough carpentry, establishing minimum standards, acceptable to UM, to be used as the basis of design for UM Coral Gables Campus.

- 06.1 General Requirements
 - 06.1.1 Submittals
 - 06.1.2 Workmanship requirements
- 06.2 Codes and Standards
- 06.3 Design Criteria
- 06.4 Specific Requirements (organized by CSI MasterFormat® 2012 Numbers & Titles)

06.1 General Requirements

UM Coral Gables Campus and UM Buildings interior architectural woodwork must comply with the following objectives:

1. Sustainable Design and products.
2. Ease of maintenance.
3. Solutions with the best value considering a life cycle cost analysis to account for the total project cost.

The design of Interior Architectural Woodwork, in concert with other building components, shall produce a project that meets the programmed sustainability rating (LEED rating).

06.1.1 Submittals

Submittals shall include product data, samples, wood treatments, sustainability data, warranties, coordination drawings and shop drawings which are coordinated with all corresponding disciplines.

06.1.2 Workmanship requirements

All Interior Architectural Woodwork is to comply with Architectural Woodwork Standards (AWS).

06.2 Codes and Standards

The design for the interior architectural woodwork and rough carpentry shall comply with the requirements of the applicable authorities having jurisdiction, and with the in-force edition at the time of the project of the following codes and standards:

1. Florida Building Code.
2. City of Coral Gables, Local Codes and Ordinances.
3. Architectural Woodwork Standards (AWS)

06.3 Design Criteria

Refer to specific requirements included herein.

06.4 Specific Requirements (organized by CSI MasterFormat® 2012 Numbers & Titles)

06 10 00	Rough Carpentry
06 40 23	Interior Architectural Woodwork

06 10 00 Rough Carpentry

Design Standards

1. Rough carpentry shall follow these guidelines:
 - a. Performance requirements:
 - 1) Fire retardant treated lumber and plywood shall be used for all interior rough carpentry.
 - 2) Preservative treated lumber and plywood used for exterior rough carpentry shall comply with AWPA U1.
 - 3) The use of adhesives, containing formaldehyde or other volatile organic chemicals that are harmful to humans or the environment is prohibited on UM projects.
 - 4) Laminated plastic shall not contain adhesives. Recycled materials are preferred over virgin materials.
 - 5) Wood products shall be produced from wood obtained from forests certified by an FSC-accredited body to comply with FSC STD-01-001, "FSC Principles and Criteria for Forest Stewardship;" foreign species are not allowed.
 - a) Where possible, products shall be obtained from Florida forests within a 500 mile radius.
 - b) Wood products shall be provided by manufacturers and vendors within the Florida region, whenever possible.
 - 6) Fastening devices shall be fabricated from stainless steel.
 - 7) **Use of wood products that include but are not limited to plywood, particle board or another type of wood sheathing for exterior building envelope sheathing or use as a component in building envelope cladding assemblies in both horizontal and vertical applications is not permitted.**

2. LEED Submittals:

- 1) Product Data for Credit EQ 4.1: For adhesives, including printed statement of VOC content.
- 2) Product Data for Credit IEQ 4.4: For adhesives and composite wood products, documentation indicating that products contain no urea formaldehyde.

06 40 23 Interior Architectural Woodwork**Design Standards**

1. Interior architectural woodwork including custom made cabinets, casework, wood paneling, wood railings and wood trim, shall follow these guidelines:
 - a. Performance Requirements:
 - 1) Countertops shall be fabricated from solid surface or stone; plastic Laminate countertops are not allowed. Refer to Division 12 for additional countertop requirements.
 - 2) The use of wall hung shelving and closet shelving is not allowed on campus.
 - 3) Properly address emissions and limitations of volatile organic compounds (VOCs). Adhesives and composite wood products containing urea-formaldehyde are prohibited.
 - b. LEED Submittals:
 - 1) Product Data for Credit EQ 4.1: For adhesives, including printed statement of VOC content.
 - 2) Product Data for Credit IEQ 4.4: For adhesives and composite wood products, documentation indicating that products contain no urea formaldehyde.
 - c. Quality assurance parameters:
 - 1) Environmental Limitations: Casework/cabinets and other interior architectural woodwork shall not be delivered or installed until building is enclosed, wet work is complete, and the HVAC system is operating and maintaining temperature and relative humidity at occupancy levels during the remainder of the construction period.
 - 2) Wood products shall be produced from wood obtained from forests certified by an FSC-accredited body to comply with FSC STD-01-001, "FSC Principles and Criteria for Forest Stewardship," and FSC STD-40-004, "FSC Standard for Chain of Custody Certification.
 - 3) Where possible, require that products be obtained from Florida forests. Foreign species are not allowed.

- 4) Source Limitations: Engage a qualified woodworking firm to assume undivided responsibility for production of architectural wood cabinets, wood paneling, and transparent-finished wood doors that are required to have sequence-matched wood veneers.
- 5) Wood Species: For transparent finish wood, select from light colored wood and wood veneers such as Maple, Ash, Red Oak, and White Oak. Veneers must be FSC US certified. Foreign species are not allowed. Deviation from this list requires UMBC Committee approval.
- 6) Architectural Woodwork Standards (AWS) quality grade to set standards on materials, construction and installation requirements, except as otherwise indicated below. Premium Grade for wood veneer finish casework and other transparent finish interior architectural woodwork. Provide Custom Grade for plastic laminate casework/cabinetwork and Interior Architectural Woodwork with plastic laminate or opaque (painted) finish. The following requirements must be included in specifications:
 - a. Core: Medium density fiberboard plywood core per AWS indicated quality grade standard. Particle board is not allowed.
 - b. Use hardwood veneer core for shelving. For casework/cabinet framing, use pressure treated solid lumber.
 - c. Casework/cabinets shall be plant assembled. Where design, delivery or site conditions require, casework/cabinets may be assembled in component units with provisions made for field connecting. Field assembly and installation must be performed by fabricator.
 - d. Type of architectural cabinet construction: Use frameless construction; flush overlay style. Deviations from this require UMBC Committee approval.
 - e. Transparent finish wood casework/cabinetwork: Veneer species, cut, and grain direction must be approved by UM.
 - 1) Interior of cabinets to have compatible species to that selected for exposed surfaces. Specify factory applied finish; AWS System 11, Premium grade - catalyzed polyurethane finish is preferred, with satin sheen. For wood veneer casework, use same wood species cut and match; coordinate with wood paneling and other exposed wood trim so that veneer is provided by same wood veneers source.
 - f. Shelving inside casework/cabinetwork: Provide adjustable shelf support. Provide multiple holes to receive pins supporting adjustable shelves. Provide shelf adjustment on ½ inch centers, unless program calls for fixed shelving.
 - g. Indicate locks for each casework/cabinet drawer and door unless otherwise requested by UM. Coordinate with UM for locking and keying requirements.
 - h. Grommets: Provide according to program requirements. Use plastic grommets.

7. Countertops: Refer to Division 12 of these standards.
8. Glass in casework/cabinetwork: Use 1/8 inch minimum tempered or laminated glass.
9. Wood trim shall be fabricated from solid lumber, except for trim items wider than available lumber, in which case use veneered construction. Comply with AWS premium grade for transparent finish trim; and AWS custom grade for plastic laminate finish or opaque finish trim. The use of opaque finish trim is discouraged. Factory finish is required in all cases.

STANDARD FINISHES FOR CABINETWORK

SPACE	CABINETWORK EXT. FINISH	CABINETWORK INT. FINISH INCL SHELVING	COUNTER TOPS
Classroom	Plastic Laminate	Plastic Laminate	Solid Surface
Science Lab/ Art Lab	Solid Oak (Wood)	Solid Oak (Wood)	Epoxy (black)
Research Labs	Solid Oak (Wood)	Solid Oak (Wood)	Epoxy (black)
Music Lab	Plastic Laminate	Plastic Laminate	Solid Surface
Storage	Plastic Laminate	Plastic Laminate	Solid Surface
Reception	Wood Veneer	Wood Veneer	Stone or Solid Surface
Staff Office	Wood Veneer or Plastic Laminate	Wood Veneer or Plastic Laminate	Solid Surface
Executive Offices/ Faculty Offices/ Conference	Wood Veneer	Wood Veneer	Stone or Solid Surface
File Storage/ Supplies	Plastic Laminate	Plastic Laminate	Solid Surface
Faculty Lounge/ Work Rooms/ Dining/Multi Purpose Rooms	Plastic Laminate	Plastic Laminate	Stone or Solid Surface
Living Areas	Plastic Laminate	Plastic Laminate	Solid Surface
Toilet Room	-----	-----	Solid Surface

- d. Product standards:
 - 1) Wood: Materials shall comply with requirements of the AWS quality standard for each type of woodwork and quality grade indicated.
 - 2) Adhesive for interior architectural woodwork:
Types recommended by AWS to suit application.

- 3) Plywood:
 - a. Concealed plywood and plywood cores: Per AWS recommendations according to quality grade specified.
 - b. Veneer core plywood shall be a non-telegraphic hardwood manufactured with exterior glue.

- 4) Plastic Laminate: Plastic laminate shall conform to NEMA LD3 for high-pressure laminate.
 - a. Plastic laminate minimum material thickness shall be as follows:
 - 1) 0.048" – Shall be used on exposed surfaces and edges of drawer fronts, door fronts, and all other remaining exposed exterior horizontal and vertical surfaces.
 - 2) 0.028" – Shall be used on exposed interior surfaces of door backs, cabinet sides, backs, and other remaining exposed interior horizontal and vertical surfaces.
 - 3) 0.028" – Shelving, tops, bottom and edges. Shelving core: Provide hardwood plywood, ¾ inch minimum. All surfaces of shelving are to be covered with plastic laminate including four edges.
 - b. Colors: Selected from manufacturer's standard color selection. For special projects, consider selecting colors from the premium selection line. Semi-exposed and interior concealed surfaces shall be same color as exterior exposed surfaces of cabinetwork.
 - c. Texture: Suede finish, unless otherwise approved by UM.
 - d. Approved manufacturers:
 - 1) Abel Laminati, Inc., Formica Corp.
 - 2) Panolam Ind.
 - 3) WilsonArt International.

- 5) Chemical-resistant, high-pressure plastic laminate to conform to NEMA3, grade HGP, tested per test procedure 3.9.5.:
 - a. Thickness: 0.034 plus/minus 0.005 inch thick.
 - b. Texture: Matte, unless otherwise approved by UM.
 - c. Approved manufacturers:
 - 1) Formica Corp. Lab Grade 840 Block
 - 2) Panolam Ind. Int'l Inc. Pionite Chemguard
 - 3) WilsonArt Int'l Div. of Premark Int'l Inch. Chemsurf.

- 6) Cabinet Hardware: Minimum standards are included in BHMA A156.9; grade classification 1.
 - a. Approved manufacturers:
 - 1) Hafele
 - 2) KV
 - 3) Stanley
 - 4) Blum
 - 5) Accuride
 - b. Materials/Finish for exposed hardware: Stainless steel 630 finish.

- c. Hinges:
 - Invisible/concealed reversible for Casework/Cabinetwork other than kitchen and Break Rooms Cabinetwork: Fabricated from stainless steel. Similar to SOSS #218; hinge size and quantity per hinge manufacturer's recommendations.
 - Invisible European type hinge for Cabinetwork in kitchen and Break Rooms: Heavy duty, institutional, similar to Blum Inc. Clip top 170 degree hinge. Consult with manufacturer as to which is the best hinge for application.
 - d. Door and drawer pulls: Solid aluminum or stainless steel wire pulls; 5/16 inch in diameter, 4 inches c. to c.
 - e. Drawer slides: Complying with BHMA A156.9, Grade 1HD-100 and Grade 1HD-200 side mounted; full extension type; zinc-plated-steel ball-bearing slides with detent in and positive stop features. Coordinate with UM for special requirements. Approved manufacturers: KV and Accuride.
 - f. Shelf rests: BHMA A156.9, B04013; metal, two-pin type with shelf hold-down clip.
 - g. Cabinet drawer/door locks; Cam locks of type to match UM campus standards and the following: BHMA A156.11, E07261 for doors and BHMA A156.11, E07051 for drawers.
 - h. Magnetic type catches, BHMA A56.9, #B03141 fabricated from aluminum.
 - i. Cable Covers/Grommets: fabricated from plastic. Color per UM's requirement for each project.
- 7) Wood Trim: Use wood trim at special function areas. The use of wood trim requires UM approval. Comply with AWI Section 6.
- a. Wood trim be assembled, sanded and finish at shop. Provide Architectural Woodwork Standards (AWS) premium grade quality standard and AWS custom grade quality when using opaque finish.
 - b. Fire retardant treatment where required by code.
 - c. Transparent finish trim: Wood species and cut as selected by Architect based on listed species; and, subject to UM approval.
 - d. Opaque finish trim: Select species from regional products if available.
- 8) Wood Paneling: Comply with AWI Section 8. Use wood veneer paneling at special function areas as approved by UMBC Committee.
- a. Call for AWS Premium grade quality standard.
 - b. Call for fire retardant treatment where required by code.
- 9) Wood Veneers for Exposed Surfaces:
- a. Grade: Premium AWI Grade
 - b. Preferred Species: Maple

- c. Grain Direction: As indicated
- d. Matching of Veneer Leaves: Slip Matching
- e. Veneer Matching within Panel Face: Balance Match
- f. Comply with veneer and other matching requirements indicated for blue-print matched paneling.
- g. Transparent Finish: transparent finish sample shall match and be submitted to UMBS for approval.

2. Performance Standards

- a. **Coordination:**
Field measure and verification of all dimensions shall be performed prior to fabrication. Cabinetwork/Casework must be coordinated with countertops covered under Division 12 of these standards.
- b. **Manufacturer / Installer Qualifications:**
Interior Architectural Woodwork shall be fabricated in Florida by certified participant in AWI Quality Certification Program and be listed as member of AWI, with a minimum of (10) years' experience in successfully producing and installing custom interior architectural woodwork including but not limited to casework/cabinet wood trim and paneling of sizes and types similar to that indicated for this project, with sufficient production capacity to produce required units.
- c. **Product Data:**
Properly identified product data shall be requested, including specifications and catalog cuts for manufactured items, such as cabinet hardware, plastic laminate, wood finishes, and adhesives.
- d. **Samples:**
Properly identified samples of the following for selection and review shall be requested.
 - 1) Cabinet hardware.
 - 2) Each wood species that is to receive factory applied transparent finish, with finish applied on one side of sample.
 - 3). Veneer leaves representative of and selected from flitches to be used for transparent-finished cabinets. Include review of flitches to be used on wall paneling and wood doors when wood veneer matching is a requirement.
 - 4) Each wood species that is to receive factory applied opaque finish, with finish applied on one side of sample.
 - 5) Plastic grommet color samples in manufacturer's full color range.
- e. **Mock-Up:**
The Architect and/or UM shall determine if full size erected assemblies are required for review of construction. A mock-up also may be used for assessing factory applied finishes.

- f. Certificates:
 - a. Submit certificates from wood treating plant or material supplier that all lumber, plywood, and resin tops supplied conforms to referenced specifications.
 - b. Qualification data from manufacturer and/or installer. Include list of completed projects with project names, addresses, names of Architects, Contractors and Owner and their phone numbers and e-mails.
 - c. Structural performance data signed and sealed by the design professional.

- g. Pre-installation Conference:
Pre-installation conference at least two weeks prior to commencing work of this section shall be coordinated.

- h. Installation: To comply with AWS.
 - a. Transparent finish wood casework/cabinetwork: Premium Grade
 - b. Transparent finish interior architectural woodwork, including trim and wood paneling: Premium Grade
 - c. Plastic laminate casework/cabinetwork: Custom Grade
 - d. Opaque finish interior architectural woodwork, including trim: Custom Grade

- e. Application of joint sealant between exposed cabinet surfaces and adjacent walls shall be included under the joint sealant section under Division 07.

DIVISION 07 THERMAL AND MOISTURE PROTECTION

This chapter identifies criteria for the design of thermal and moisture protection systems in UM buildings with the purpose of establishing minimum standards, acceptable to UM, to be used as the basis of design for UM Coral Gables Campus. Thermal and Moisture Protection systems/products must be selected to provide weather tight, thermally efficient work environment for the occupants in a sustainable and reliable design.

- 07.1 General Requirements
 - 07.1.1 Submittals
 - 07.1.2 Workmanship requirements
- 07.2 Codes and Standards
- 07.3 Design Criteria
- 07.4 Specific requirements (organized by CSI Master Format® 2012 Numbers & Titles)

07.1 General Requirements

UM buildings thermal and moisture protection systems/products must be designed to comply with the following objectives:

1. Life cycle costs and expected service life.
2. Hurricane (High Velocity Wind Zone) Resistance and Impact Resistance.
3. Warranty.
4. Structural dead load analysis and considerations.
5. Long-term vs. short term building ownership and expectations
6. Systems and materials compatibility.
7. Roof slope and drainage capacity of both primary and secondary drainage.
8. Sustainable design, providing efficiency and reducing total building energy consumption.
2. User comfort.
3. Ease and uniformity of maintenance.
4. Solutions with the best value considering a life cycle cost analysis to account for total project cost

The design of the thermal and moisture protection systems/products shall be selected to produce a building that meets the project's programmed sustainability rating (LEED rating).

07.1.1 Submittals

Submittals shall include product data, shop drawings, samples and coordinated shop drawings including all disciplines using same spaces.

07.1.2 Workmanship requirements

Refer to specific requirements under each section included herein.

07.2 Codes and Standards

Thermal and moisture protection systems/products shall comply with the requirements of the applicable authorities having jurisdiction including but not limited to the following:

1. Florida Building Code - High Velocity Wind Zones (HVWZ) for new construction, replacements and re-roofing's scope such as ASCE-7.
2. Miami-Dade County Product Approval (NOA) using RAS and TAS standards.
3. Underwriters Laboratories UL-790 and ASTM E-108 standards for Class "A" fire rated roof coverings.
2. City of Coral Gables - Zoning, Local Codes and Ordinances
3. Standards included under each section

07.3 Design Criteria

Refer to specific requirements under each section included herein.

07.4 Specific requirements (organized by CSI Master Format® 2012 Numbers & Titles)

07 01 50.19	Preparation for Re-Roofing
07 10 00	Damp-proofing and Waterproofing
07 18 00	Traffic Coatings
07 21 00	Thermal Insulation
07 52 00	Roofing
<u>07 52 13</u>	<u>SBS Modified Bitumen Bituminous Membrane</u>
<u>07 54 16</u>	<u>Ethylene-Propylene (KEE) Roofing</u>
<u>07 54 19</u>	<u>Polyvinyl-Chloride (PVC) Roofing</u>
07 60 11	Flashing and Sheet Metal
07 70 00	Roof Specialties, Accessories and Skylights
07 81 00	Applied Fireproofing
07 92 00	Joint Sealants
07 95 00	Expansion Control

07 01 50.19 Preparation for Replacement / Re-roofing

Design Standards

1. The intent of these standards is to provide general guidelines on the design and provision for roofing scope of new or existing building. These standards shall not supersede code and regulations nor relieve the design professional from their professional responsibility.
2. The Design professional shall be required to submit the recommendations for review and approval of the roofing system to Facilities Management Design & Construction prior to commencement of the design scope.

3. Unless otherwise required by the UMBC Committee, existing roofing systems shall be evaluated to determine the appropriate scope for either a recover or replacement strategy. If the existing system is determined as a result of testing results to require a replacement, the system shall be completely removed, including insulation, down to the structural deck and reroofed.
3. Comply with local and state building code provisions.
4. If reroofing work is above or adjacent to an existing roof not requiring replacement, specify protection requirements to the existing roof to remain. If the existing roof is under warranty, contact the warrantor to determine if it has protection recommendations and requirements and if roofing needs to be inspected after construction of adjacent new roofing is complete.
5. It is recommended that an experienced, qualified professional roof consultant be hired to evaluate existing conditions and to recommend re-roofing procedures and roofing products. Evaluation should include but not be limited to:
 - a. Assessment of the structural integrity of the deck.
 - b. Roof condition and age.
 - c. Roof system evaluation for recover vs. replacement strategies.
 - d. Verification of working and non-working fans and other roof mounted mechanical equipment.
 - e. Visual verification of existing roof slope/ drainage.
 - f. Verification of proposed or existing primary and secondary drainage capacity through design professional provided drainage calculations.
 - f. Types of existing expansion joints and roof controls joints.
 - g. Comparative analysis of building code requirements as applicable.
 - h. Investigation of roofing system for the presence of asbestos-containing roofing materials.
 - i. Access condition of Sheet metal flashing to determine if existing sheet metal flashing can be reused and if it complies with Florida Building Code High Velocity Hurricane Zones (HVWZ) Requirements.
 - j. Verify project qualifications for the insulation system and installation so as to meet the FPL roofing insulation rebate program wherever possible.
6. Evaluate any roofing system that is less than 10 years old from the date of substantial completion that has been identified as failing, the design professional consultant shall evaluate and determine reasons for failure or reduced service-life. Determine if areas other than roofing are causing water, moisture or vapor intrusion, including but not limited to sealant failure at windows and other exterior envelope openings. The design professional shall make recommendations to include if roof repairs will suffice or if new roof system necessary to avoid further leakage and any other additional scope related to the building envelope conditions as needed.

Product Standards

1. Specify products recommended and selected by the UMBC Committee and from a selected roofing manufacturer.

Performance Standards-Minimum

1. The following requirements are to be included in the specifications:
 - a. On-site, pre-design conference to review project data and recommendations.
 - b. Compliance with governing EPA notification regulations before beginning membrane and system roofing mitigation if hazardous materials are tested and discovered to be present.
 - c. Compliance with hauling and disposal regulations of authorities having jurisdiction.
 - d. On re-roofing projects, when a total roof replacement is required, specify an adequate temporary seal to ensure weathertightness during re-roofing operations.
2. Request that that only the portions of the existing roofing system that can be replaced with new system the same day be removed. In some special cases due to specific project conditions an installation of temporary roof may be required; in such cases the roofing contractor, together with recommendations from the roofing manufacturer, shall submit a temporary roofing proposal to UM for review and approval; the proposal shall include recommendations from the roofing manufacturer as to whether temporary roofing should remain in place. Temporary roof shall meet local building code requirement.
3. The Design Professional shall consider upgrading the existing roofing insulation R value to a minimum required by FBC for new construction when possible when structural loads, minimum flashing conditions, wall heights and equipment heights permit. Verify that the increased insulation will not impact the roofing system, fire performance and/or roofing heights in reference to drains, parapet walls and other roof edge/termination conditions.
4. Request inspection of deck substrate after removing existing roof system down to deck. Request the inspection of existing wood nailers scheduled to remain or be reused to verify that they are in good condition and that the nailer's attachment meets current FBC high velocity wind zone current and ASCE requirements. Require that wood nailers be replaced with new pressure treated wood nailers if conditions listed above are not met.
5. Request inspection of existing roof penetrations and drains; The Design Professional shall be present during these inspections. Seek suggested recommendations from the design professional as to the feasibility and need for raising equipment on roof in order to achieve minimum flashing requirements.
6. Request water testing of existing roof drains during each stage of re-roofing, and roof drain plugging and plug removal requirements.

7. Design the roof deck with a minimum $\frac{1}{4}$ " per (2-1/2:12) foot slope for low-slope-roof conditions.
8. Low-slope roof design shall incorporate a 20-year, "NDL" no-dollar-limit manufacturer guarantee for both roofing, insulation and accessories
9. Roofing systems of dissimilar materials within a same roof plane level should not be specified or installed. If the roof system condition warrants installation of two different materials. In order to avoid material incompatibility shall incorporate into the design professionals design solution an area divider, expansion joint or other means of termination / materials separations to define warranty limits and maintenance responsibilities as well as mitigate cross material contamination that could lead to a roof system failure not covered by the manufacturers guarantee.
10. The use of thermo-plastic sheet roofing systems should not be considered in facilities that are exposed to prevalent vandalism, heavy traffic or corrosives conditions.
11. Base sheets are required at all installations over cellular insulating concrete roof decks and other Nailable substrates.
12. At all installation using mineral surfaced granule cap sheets. Provide matching granules to cover all exposed bitumen.
13. All base flashing at all asphalt based roofing systems shall be a two-ply flashing system with a minimum eight inch vertical height above the finished roof surface.
14. The Design professional as a standard at all parapet walls conditions less than 3'-0" in height should be "wrapped" with membrane materials, termination bars and coping caps. At all walls that exceed 3'-0" in height above finished roof a counterflashing with termination bar along with waterproofing for any exposed interior and horizontal portions of the parapet wall should be considered as a UM desired design solution.

07 10 00 Dampproofing and Waterproofing

Design Standards

1. The intent of these standards is to provide general guidelines on the design and provisions for building damp proofing waterproofing systems. These standards shall not supersede code and regulations nor relieve the Design professional from their professional responsibility
2. Select waterproofing products that have Miami-Dade Product Approval (NOA) and comply with ASCE requirements for the specific requirements of the project.

3. Design professionals shall consider and provide waterproofing systems at the inside face of all retaining walls, planter walls and planter floors where the outside face is exposed or part of a wall or ceiling exposed to hydrostatic pressure. Use of crystalline concrete waterproofing should be considered on all below grade structures in new construction applications in lieu of waterproofing if design and intent conditions permit its use.
4. Comply with applicable building codes and regulatory agency requirements.
5. On complex projects consider hiring an Independent moisture and waterproofing consultant registered with RCI or equivalent substituted licensure as a Roofing Contractor.
6. Where the term “Manufacturer Technical Representative” is used, the term means an employee of the manufacturer who is trained and licensed by manufacturer to provide technical advice to architect on material, systems and installation methods; and to provide field observations. Manufacturer Technical Representative is not the product installer.
7. Installers must be authorized, certified, or licensed by the waterproofing manufacturer.
8. As follows are the standards for damp proofing, waterproofing systems and water repellent systems, including:
 - a. Hot and cold bituminous or rubberized damp proofing.
 - b. Self Adhering Sheet Waterproofing.
 - c. Hot and Cold Fluid Applied Waterproofing.
 - d. Water repellents coatings
 - e. Concrete crystalline admixtures for new construction applications below grade. Refer to Division 03 “Concrete” for additional information and coordination requirements.
9. Bituminous damp proofing:
 - a. Damp proofing treatments are intended to resist the passage of water if no hydrostatic pressure is present.
 - b. Use bituminous damp proofing on exterior cavity walls. Select bituminous damp proofing with a maximum VOC content of 100 g/L.
 - c. Recommended Type: Hot Applied Emulsified Asphalt Damp proofing. Other types of damp proofing may be required to meet condition requirements. Consult with waterproofing design professional and system manufacturers’ for the best suited system for site conditions and building components.
10. Waterproofing Systems:
 - a. Self adhering sheet waterproofing and hot or cold fluid applied waterproofing require surface preparation, moisture testing, and priming.
 - b. Listed systems are for concealed application and require protection board.
 - c. Use of self adhering sheet waterproofing is required in vertical below grade areas, including but not limited to elevator pit walls. Seek assistance from waterproofing manufacturer to determine if selected waterproofing is suitable to site conditions.

- d. In other areas, the design professional should determine, based on specific conditions and recommendations from waterproofing expert/consultant, which waterproofing, whether self-adhering sheet, hot or cold or fluid applied, will perform best.
 - (1) VOC content for self adhering sheet waterproofing membrane: 0 g/L.
Maximum VOC content of system primer and sealer: 200 g/L
 - (2) Maximum VOC content for cold fluid applied waterproofing system: 220 g/L.
 - (3) Maximum VOC content for hot fluid applied waterproofing system: 220 g/L
 - e. For exposed waterproofing system, use system best suited for application and exposure. Refer to Traffic Coating Section included in this section of standards.
11. Water repellent systems:
- a. Use clear, penetrating water repellent sealer, either silane or siloxane system. Choose best system suitable for surfaces indicated to receive water repellent coating. Select water repellent with a maximum VOC content of 600 g/L.

Product Standards

- 1. Damp proofing: Cold applied cut back asphalt damp proofing, complying with ASTM D1227 for trowel, brush or spray application:
 - a. Manufacturers:
 - (1) BASF Construction Chemicals.
 - (2) Euclid Chemical Company (The); an RPM company.
 - (3) Karnak Corporation.
 - (4) Koppers Inc.
- 2. Self Adhering Composite Sheet Waterproofing (Peel and Stick Membrane):
 - a. Acceptable Manufacturers and Products:
 - (1) Carlisle Coatings & Waterproofing Inc.
 - (2) CETCO Building Materials Group.
 - (3) Tyvek Systems, Inc.
 - (4) W.R. Grace and Co.
- 3. Sheet Thickness: 60 mils minimum.
- 4. Protection board: As recommended by manufacturer of sheet membrane.
- 5. Surface Mounted Reglets: Fabricated from stainless steel of design per manufacturer's recommendations.
- 6. Bonded High Density Polyethylene (HDPE) Sheet for Horizontal Applications on the "blind side" or inaccessible side of a cast in place concrete slab before concrete is poured, such as application under elevator pit slabs: 46 mils thickness.
 - a. Manufacturers and Products:
 - (1) W.R. Grace and Co. "Preprufe."

7. Cold Fluid Applied Waterproofing:
 - a. One component moisture curing or two-component urethane type waterproofing suitable for covered non-traffic locations.
 - b. Acceptable Manufacturers and Products:
 - (1) Carlisle Coatings and Waterproofing, Inc. "Miraseal"CCW 5413.
 - (2) Tremco, Inc.: Tremproof 201/60 or Tremproof 250GC.
8. Hot Fluid Applied Waterproofing:
 - a. Single component 100% solid, hot fluid applied rubberized asphalt waterproofing system for covered horizontal areas..
 - b. Manufacturers and Products:
 - (1) Carlisle Coatings and Waterproofing, Inc. CCW 500R.
 - (2) American Hydrotech, Inc., Monolithic Membrane 6125 / 5413.
Minimum: 215 mils minimum
9. Water Repellents:
 - a. Clear water repellent coating for horizontal surfaces of concrete, masonry and precast concrete: Penetrating, silane 40% solid water repellent coating.
 - b. Manufacturers:
 - (1) Degusa, Inc.
 - (2) Kryton, Inc.
 - (3) Sika Corporation, Inc.
 - (4) Textured Coatings of America, Inc.
 - c. Clear water repellent coating for vertical surfaces of concrete, masonry and precast concrete: Penetrating, silane 20% solid or siloxane water repellent coating.
 - d. Acceptable manufacturers.
 - (1) Degusa
 - (2) Sika Corporation, Inc.
 - (2) Textured Coatings of America, Inc.
 - (3) Tnemec Chemprobe Corp.
 - (4) Pecora.

Performance Standards-Minimum

1. Manufacturer / Applicator/Installer Qualifications: The design professional shall require:
 - a. An affidavit from the manufacturer approving applicator prior to installation.
 - b. Applicator shall have a minimum five years documented experience installing specified systems and shall have successfully completed at least five projects of similar size and complexity.
2. Contractor Submittal requirements:
 - a. Properly identified product data, including performance data.
 - b. Shop drawings for waterproofing system, indicating terminations, overlapping with different waterproofing or other substrates, sheet metal flashing, coordination with other trades, prepared by system manufacturer.
 - c. LEED Certificates.

- d. Miami-Dade Product Approval (NOA).
 - e. Maintenance manuals.
 - f. Copy of project specific warranty.
 - g. Mockup sample for water repellent
3. Field Testing for all waterproofing and water repellent systems.
 4. Compatibility and Conditions:
 - a. Specifications to include the following requirements:
 - (1) Waterproofing manufacturer's technical representative shall inspect and approve surfaces to receive waterproofing prior to start of the work.
 - (2) Waterproofing manufacturer's technical representative shall periodically inspect the work; and shall be present and observe field testing at completion of installation.
 - b. Waterproofing manufacturer's technical representative shall report unsatisfactory surfaces to receive waterproofing and unsatisfactory materials and workmanship to Contractor, a design professional, and UMBS Project manager.

Field Quality Control

1. Include the following minimum requirements in specifications
 - a. Manufacturer's technical representative shall be onsite prior to application, during first stages of application, and at intervals required to ensure that preparations are adequate and that material is being applied according to manufacturer's written recommendations and Contract requirements.
 - b. Testing: In presence of waterproofing system manufacturer's technical representative, design professional and UMBS project manager, flood test each deck area, according to recommendations in ASTM D 5957 at vertical waterproofed areas, using testing methods in accordance to manufacturer's written recommendations. Perform testing after completing waterproofing but before overlying construction is placed. Install temporary containment assemblies, plug or dam drains, and flood with potable water.
 - c. Manufacturer's material and labor warranty may require independent testing agency. Review warranty language and include following requirement when applicable:
 - d. Owner will engage independent testing agency to observe flood testing and examine underside of decks and terminations for evidence of leaks during flood testing.

Warranty

1. A minimum of five year product warranty should be required with 10+ years as optimal.
2. Verify with product/system manufacturer available warranties.
3. Verify if manufacturer/installer warranties are available.

07 18 00 Traffic Coatings**Design Standards**

1. These guidelines describe the minimum physical requirements for traffic coatings.
2. When desiring greater control, the Design professional must determine if the specific project conditions require additional physical properties. Requirements may include minimum tensile strength, hardness, permeability, hydrolytic stability, water absorption, undercoat adhesion, and tear resistance.
3. Minimum recommendations for traffic coatings include the following:
 - a. Moisture in concrete adversely affects coating adhesion. Request that manufacturer's recommendations must be followed regarding preparation and application.
 - b. Lightweight insulating aggregate concrete is always an unsuitable substrate.
 - c. Directly applying traffic coatings to un-topped structural precast concrete decks is not recommended.
 - d. Durability: The service life of traffic coatings varies from 5 to 7 years. The service life is affected by many variables including quality of the substrate, type of deck, workmanship quality, traffic loading severity, and degree of exposure of the traffic coatings to the ultra violet rays, sun and the weather. The Architect must consider the above variables as they applied to the specific project conditions for the selection of the appropriate product.
 - e. VOC content for Traffic Deck Coatings: 100 g/L or less.

Product Standards

1. Acceptable Manufacturers
 - a. Deck Waterproofing for Exterior and Interior Pedestrian Traffic; and Equipment Room Floors:
 - (1) Tremco
 - (2) Neogard
 - (3) Carlisle Coatings and Waterproofing Systems
 - (4) Sika Corporation, Inc.
 - b. Deck Waterproofing for Vehicular Traffic:
 - (1) Tremco
 - (2) Neogard
 - (3) Carlisle Coatings and Waterproofing Systems.
 - (4) Sika Corporation, Inc.

Performance Standards

1. Design professional to request the following submittals:
 - a. Product Data. Include VOC data.
 - b. Shop Drawings showing extent of each type of traffic coating and termination points, including termination details.
 - c. Color Samples.
 - d. Copy of Warranty.

- e. Letter from manufacturer approving applicator.
 - f. Maintenance Manual.
 - g. Maintenance service proposal.
 - h. Mockup sample.
2. Manufacturer / Applicator Qualifications:
- a. Applicator shall have a minimum of five ten years of experience installing specified system and shall have successfully completed at least five projects of similar size and complexity.
3. Warranty: Upon completion and acceptance of the work, an executed copy of joint warranty shall be submitted and signed by the manufacturer and contractor agreeing during a five year period to replace defective work and/or material without additional cost to the Owner. Warranty shall also cover removal and replacement of overburden.
4. Total dry thickness for pedestrian traffic coating: 40 mils minimum. Total dry thickness for vehicular traffic coating: 63 mils, except at areas of heavy traffic dry thickness to be 93 mils.
5. Request membrane to be carried up vertically a minimum of 4 inches. Request that a flood test be performed after installation. Manufacturer's representative of system is to be present during flood test.

Field Quality Control

1. Manufacturer's field service: The design professional shall request the services of a manufacturer's technical representative to inspect the preparation and application of materials. The manufacturer's technical representative must visit the site before the installation, one visit during installation, and one visit after completion.
2. Request water tightness verification of a traffic coating above an occupied space by field testing for leaks. Use methods recommended in writing by manufacturer. When there are no manufacturers recommendations available, include requirement for the following test.
- a. Flood Testing
 - b. Electronic Leak Detection (to be used as a minimum and when Flood testing is not feasible)
3. Testing to be performed by an independent qualified testing laboratory paid by UM.

07 21 00 Thermal Insulation**Design Standards**

1. The intent of these standards is to provide general guidelines for the use and on the design and provisions for thermal insulation. These standards shall not supersede code and regulations nor relieve the Design professionals from their professional responsibility. Design the thermal insulation system to fully protect the building envelope.
2. Do not indicate thickness of insulation; indicate required thermal resistivity (R) value in drawings and specifications. Required R values should be determined by the mechanical engineer and energy modeling program that should be provided prior to the scope of work being performed.
3. Selection of insulation should be preceded by a careful analysis of applicable building codes and building regulations, including but not limited to combustion, flame spread, and smoke development.
4. Where insulation is faced on one side of board, the location of vapor retardant facing should be determined by the mechanical engineer.

Product Standards

1. Select products that have recycled content.
2. Request during submittal process documentation indicating percentages by weight of postconsumer and pre-consumer recycled content as required by LEED Credit MR4.
3. Manufacturers of Thermal Insulation:
 - a. Boards:
 - (1) Polyisocyanurate insulation, foil faced on both sides of board with no HCFC blowing agents. Use the long term thermal-resistance (LTTR) method for determining and reporting. R-values. Maximum flame-spread and smoke-developed indexes of 75 and 450, respectively, per ASTM E 84.
 - (a) Manufacturers:
Dow Chemical "Thermax" Sheathing
Atlas
Rmax
 - (2) Glass Fiber Board Insulation, foil faced on one side of board, with low emitting formaldehyde (less than 0,05-ppm) as approved by the "Greenguard" Environmental Institute. Select density best suited to conditions. Board insulation is available in several densities. Select board with higher density at exposed locations. Maximum flame-spread and smoke-developed indexes of 25 and 50, respectively, per ASTM E 84. At locations, such as mechanical rooms, where insulation will not be covered by other building materials, consider using wire mesh or similar material to protect insulation from damage.
 - (a) Approved Manufacturers:

- Owens Corning
John Manville
Knauf Insulation
- (3) Extruded-Polystyrene Board Insulation for application between slabs: 60 psi compressive strength Maximum flame-spread and smoke-developed indexes of 75 and 450, respectively, per ASTM E 84.
 - (4) Basement Wall Insulation Drainage Panels: Extruded-polystyrene board insulation Drainage Panels for application at exterior face of basement walls: 25 psi compressive strength.
- b. Blankets:
- (1) Foil-Faced, Glass-Fiber Blanket Insulation. Maximum flame-spread and smoke-developed indexes of 75 and 150, respectively, per ASTM E 84.
 - (a) Approved Manufacturers:
Owens Corning
John Manville
Knauf Insulation
 - (2) Foil-Faced Mineral Wool Blanket Insulation: Maximum flame-spread and smoke developed indexes of 25 and 0, respectively per ASTM E84.
 - (a) Approved Manufacturer:
“Thermafiber” FS-25.
- c. Insulation Fasteners and Adhesives:
Specify insulation fasteners and adhesives recommended in writing by manufacturer and as required to suit conditions.

Performance Standards-Minimum

- 1. Requirements to be included in specifications
 - a. Surface burning characteristics of insulation per ASTM E84
 - b. Combustion Characteristics of insulation per ASTM E 136.
 - c. LEED data concerning recyclable content.
 - d. Compliance with required R values, applicable building code and energy program.
- 2. Where insulation is shown installed between framing members, coordinate thickness of insulation with depth and spacing of metal studs, metal furring, or other supports.
- 3. Insulation vapor barrier (foil facing) should face warm side of building in accordance with mechanical engineer and insulation manufacturer’s recommendations.
- 4. Install wire mesh or similar means over exposed insulation to protect from damage as recommended by insulation manufacturer.

07 52 16 / 07 54 16 / 07 54 19 ROOFING

1. General

- a. Basis of design shall be a 20 year, "No Dollar Limit" (NDL) manufacturer warranted, using the following UMBS preferred roofing membrane system(s) manufacturers such as a 3-ply minimum styrene butadiene styrene (SBS) modified bitumen mineral surfaced roofing system for the SBS system, Ethylene-Interpolymer (KEE) roofing and/or Polyvinyl-Chloride (PVC) roofing membrane for low sloped roofs. UMBS shall be consulted prior to acceptance of roof system prior on UM sloping roof applications. This requirement is required on a per condition basis before starting roof design. All University of Miami roofing membrane systems shall be a fire rated roofing membrane standard.
- b. Manufacturers for SBS Styrene Butadiene Styrene Modified Bituminous Mineral Surfaced Membrane:
 - a. GAF Materials Corporation, Inc.
 - b. Siplast Membrane Systems, Inc.
 - c. Soprema Inc.
- c. Manufacturers for Ethylene-Interpolymer (KEE) Roofing Membrane:
 - a. Seaman's Corporation, Inc. Fibertite Systems.
- d. Manufacturers for Polyvinyl-Chloride (PVC) Roofing Membrane:
 - a. Sika-Sarnafil Corporation, Inc.
 - b. GAF Materials Corporation, Inc.
 - c. Dura-last, Inc.
- e. All other brands required approval by University of Miami Building Standards Committee (UMBSC).
- b. Roof designs shall comply with the following:
 - (1) Florida Building Code (FBC), including FBC - Roofing Application Standards (RAS), and FBC - Test Application Standards (TAS).
 - (a) The entire roofing assembly shall be tested to comply with the missile impact requirements of SSTD 12-99.
 - (2) Miami-Dade County Product Control.
 - (3) Underwriters Laboratories UL-790 and ASTM E-108 requirements for Class "A" fire rating for roof coverings.
 - (4) American Society of Civil Engineers (ASCE) 7-09.
 - (5) Uplift requirements based on the basic wind velocity pressures for the project according to the following:
 - (a) Provide calculations, signed and sealed by a Florida registered professional structural engineer, establishing wind velocity pressure

- values for the specific project according to ASCE 7 map wind speed of 180 mph “ultimate wind speed”.
- (6) Roofing manufacturer's specifications.
 - (7) Energy Star roofing that complies with UMBS standards.
- c. Limit roofing system and materials to uniform system with one roofing system type at a facility where possible. Use of additional or different materials for roofing system will require UMBS approval on a per condition basis.
 - d. Different roofing systems on a single building are not desired. If needed, all materials shall be separated by area dividers, control joint, expansion joints, changes in transitions, parapet walls, change of elevations, or any other means of termination to define warranty/liability limits and maintenance concerns.
 - e. Provide proper disposal of rainwater from roofs by primary drainage, and secondary drainage components such as working scuppers, overflow scupper, gutters, and downspouts complying with FBC - Plumbing requirements.
 - (1) Interior roof drains are not allowed.
 - (2) Ponding, for any period of time on any roof surface, is not allowed.
 - f. Products containing asbestos are not allowed.
 - g. Design and locate traffic pads from roof scuttles and access doors to roof mounted equipment requiring maintenance or repair. Provide a fully adhered nonskid surface of a suitable University of Miami accepted different color than the roof deck. Install access ladders at roof-to-roof transitions exceeding 24” in height. Design and locate traffic pads or membrane surface sacrificial layer at all ladder landing, at work sides of all roof mounted equipment that may require maintenance or repair, roof access and door and on three sides of roof hatches.
 - h. See Division 05 and FBC - Roof Assemblies and Rooftop Structures for equipment framing support requirements.
 - i. Membrane lap seams shall be positioned to expel water with no water laps.
 - j. Specify the contractor, at project completion, to furnish roofing material to University of Miami-Facilities Maintenance Department for 100 square feet of replacement roof for each type of system installed.
 - k. Provide secure anchorage with continuous cleats and fastenings at edge drip and parapet coping flashing conditions according to the most stringent applicable code requirements.
 - l. Parapets.
 - (1) Parapet or adjoining walls that are 48” or less in heights so parapet wall flashing felt shall not exceed a height of 24 inches above the finished roof deck.

- (a) Provide a termination bar along the top edge of the base flashing and wrap the remaining vertical stucco or pre-cast surface, including the top of the parapet or adjoining wall.
 - (b) Roof membrane flashing shall cover the interior face of the parapet, wrap wood nailers secured to the top of the parapet, and be covered by a metal coping cap at the top of the parapet wall.
 - (c) Use roofing systems manufacturer's recommended primer at wall areas receiving bitumen type felts.
 - (d) Coping shall have outer hold-down cleats and be face fastened at inward facing parapet components with removable grommet type fasteners.
 - (e) Slope top of parapets, nailers, and copings 1 inch per foot down to wall's interior face.
 - (f) Provide termination bars at the upper felt flashing vertical edge according to RAS 111 where required.
- (2) Parapet or adjoining walls over 48 inches shall have roof membrane flashing between 8 to 24 inches in height above the finished roof deck and supplemental flashing or waterproofing/felt installation beginning from new metal counter flashing with a flat profile flange and cover the interior face of the parapet, wrap wood nailers secured to the top of the parapet, and be covered by a metal coping cap.
- (a) Seal built-up roof flashing with cold bitumen and roofing tape according to manufacturer's requirements.
 - (b) Adhere or heat weld thermos-plastic membranes per manufacturer recommendations.
 - (b) Provide term bars at the upper felt flashing vertical edge according to RAS 111.
- (3) Parapets at precast and tilt wall construction shall comply with required parapet flashing and the following.
- (a) Tilt-up wall panel joints shall not have decorative reveals on the interior roof side of the wall within 2" minimum above the counterflashing. Specify that all joint sealants shall be placed before the parapet wall flashing or waterproofing are installed.
 - (b) For existing parapet walls over 24 inches in height, use roofing sealants compatible with the tilt wall sealants for closure at the tilt wall joints and counter flashing flange before waterproofing/felt / membrane installation.
 - (c) Provide wood nailers and coping between panel joints and allow for expansion/contraction.
 - (d) Slope top of precast parapets 1 inch per foot down to interior face.
- (4) Provide 24 inch high maximum roof membrane flashing when flashing is required at adjacent building walls.
- (a) Waterproofing is required for remaining vertical stucco or precast surfaces.
 - (b) Mopped down roof systems or any other systems using asphalt as an adhesive, over concrete roof decks shall have means to provide proper venting to eliminate blistering.
- (5) No roof system shall be mopped/adhered directly to a concrete deck.

- (6) A concrete primer and a vented base ply or insulation over interior or exterior spaces shall be included in the manufacturer's rated uplift classifications as determined by American Society of Civil Engineers (ASCE) 7.
 - (7) Lightweight concrete roof decks shall receive a nailed vented base sheet for hot applications or felt back applications for thermo-plastic membrane applications.
 - (8) Provide metal roof vents, according to roofing system manufacturers Recommendations, on lightweight concrete roof decks at a rate of 1 vent per 900 square feet for any roofing membrane or as approved by the roofing system manufacturer.
- m. Green Roof Standards requires approval by University of Miami Building Standard Committee (UMBSC).
 - n. Trafficable roofing for roof top activities requires approval of UMBSC.
 - o. Provide substrate waterproofing at all roof / terrace tile applications.
2. Low-Sloped Roofs.
- a. Low sloped roofs at new construction shall be installed using the membrane manufacturer and systems indicated in these criteria. Specifically for SBS modified bitumen polyester reinforced membranes of the granular mineral surfaced cap sheet over one modified polyester reinforced smooth surface inner ply all fully adhered with asphalt shall be used. A base sheet shall be included if required by FM listing.
 - (1) Roof slopes shall not exceed 2-1/2:12. Verify Class "A" fire rating for proposed slope and comply with FBC - Table 1519.3A.
 - (2) Comply with FBC, and roofing manufacturer's specifications slopes, including crickets, shall be at least 1/4" per foot.
 - b. Slopes configurations used as a reroofing solutions of roofing membranes, including crickets, shall be at least 1/8" per foot to existing drains or scuppers. Ponding shall be corrected according to FBC High Velocity Hurricane Zones - Roofing Considerations.
 - c. Separate different roofing membrane materials with a curb, expansion joint or other means of terminations to define warranty/liability limits and maintenance concerns.
 - d. Do not use at thermo-plastic membranes in roofing as exposed to vandalism, heavy traffic, or corrosive atmospheres.
 - e. For hot or heat welded asphalt applications base sheets are required for the following conditions:
 - (1) At lightweight concrete roof decks and other nailable substrates, provide a mechanically attached channel vented base sheet.

- (2) If required for manufacturer's FM uplift certification, provide a fully adhered base sheet over a proper substrate.
 - f. At granular mineral cap sheets, provide matching granules to cover exposed bitumen.
 - g. Mop applications of roofing materials require acceptance by University of Miami on a per condition basis.
 - h. An SBS cap sheet with other than a mineral granule topping requires prior acceptance by UM on a per condition basis.
3. High Sloped Roofs.
 - a. Use the following systems for roofs with slopes of 3-1/2:12 or greater:
 - (1) Clay tile and concrete roof tiles, only to match existing conditions
 - (2) Asphalt shingles, only to match existing conditions.
 - b. Metal roofs are not allowed except for prefabricated metal walkway covers in Division 10.
4. Re-Roofing Procedures.
 - a. Comply with FBC High Velocity Hurricane Zones - Reroofing.
 - b. The A/E will receive a work order, from University of Miami, for the re-roofing/testing of a specific facility and a University of Miami re-roofing data sheet.
 - c. Identify defective portions of roof decks to be replaced before re-roofing.
 - d. The re-roofing data sheet shall be submitted to UM before roofing system selection and furnish the following:
 - (1) Roof condition.
 - (2) Age of roof.
 - (3) Verification of existing insulation.
 - (4) Verification of working and non-working exhaust vents and other mechanical equipment.
 - (5) Type of existing structural deck.
 - (6) Type of existing roof system.
 - (7) Comment on failure of existing roof system.
 - (8) Visual verification-of slope/drainage.
 - (9) Type of expansion joints.
 - (10) Amount of roof work.
 - (11) Recommendation of an overlay versus removal of the roof.
 - (12) Existing cracking of roof or structure noted and subsurface conditions noted.
 - (13) Existing cracking or leaks of parapet walls noted and parapet repair added to scope of work.

- e. Schedule an on-site pre-design conference with UM Facilities Maintenance project manager to review project data sheet and recommendations. Record discussions and agreements and provide the minutes to the UM representatives.
- f. Identify defective portions of roof decks to be replaced before reroofing.
- g. Request from UM and schedule necessary tests including, but not limited to the following core samples to verify:
 - (1) Existence of asbestos roofing materials.
 - (2) Number of existing roof systems.
 - (3) Existence of insulation, value of thermal quality, and moisture content of insulation.
 - (4) Type and condition of existing structure to verify structural capacity and if capable of supporting an overlay.
- h. After receiving satisfactory test results and if an overlay system is recommended by the A/E, an uplift test and applicable fastener pull out test are necessary to verify compliance with the uplift requirements for the basic wind speed for the project location per the Florida Building Code (FBC).
- i. Coordinate insulation installation with FPL roofing insulation rebate program and University of Miami if available.
- j. A roof deck shall not carry more than 2 roof systems.
- k. A total system removal requires an adequate temporary seal to ensure weather tightness.
- l. Roof Membrane Flashing.
Where walls cannot be felt wrapped or waterproofed:
 - (1) Clean and prime, according to roof system, the exposed wall to receive new wall flashing membrane according to this Division.
 - (2) Seal built-up roof flashing felt with cold bitumen according to manufacturer's requirements and roofing tape over term bar and fasteners.
 - (3) Seal and fasten single-ply roofs with accepted sealant and term bar.
 - (4) Seal upper edge of metal counter flashing with approved sealant.
 - (5) Verify expansion joint locations to determine flashing requirements.
 - (6) At low parapets, not on the building perimeter, wrap completely with roof flashing material.
 - (7) Continue roof flashing to underside of adjacent higher roof deck edge metal.

07 60 11 FLASHING AND SHEET METAL

1. Comply with RAS 111 and FBC High Velocity Hurricane Zones - Weather Protection and Materials.
2. Flashing metal shall comply with SMACNA, latest standards:
 - a. New and re-roofing installations: Type 302 or 304 – 20 gage, 22 gage and 24 gage stainless steel.
 - b. Historical buildings: Type 302 or 304 – 20 gage, 22 gage and 24 gage stainless steel or metal to match existing as accepted by University of Miami, on a per condition basis.
3. Flashing shall have an 8 inch minimum vertical height above finished roof system surface and be at roof openings, parapet walls, curbs, mechanical equipment, and any other surfaces intersecting the roof plane. Except at curbs and other roof mounted items designed to receive 8 inch high flashing, extend other surfaces intersecting the roof plane at least 14 inches from the finished roof membrane. Coordinate with Divisions 15 and 16,
4. Gutters and Downspouts:
 - a. Comply with RAS 111 and FBC High Velocity Hurricane Zones - Weather Protection.
 - b. Provide downspouts for rainwater disposal from roofs.
 - c. Provide gutters and downspouts at edge of roof perimeters. Built-in gutters behind parapets and parapet top gutters are not allowed.
 - d. Gutters, downspouts, scuppers, and conductor heads shall be stainless steel. Comply with SMACNA - Architectural Sheet Metal Manual, latest edition.
 - e. Downspouts within 9 feet of finish grade or a slab shall be ductile iron or Schedule 80 PVC. Coordinate connections to stainless steel components.
 - f. Connect downspouts to storm drain systems.
 - g. Downspouts shall be connected to a drainage system. Downspouts discharging on grade require University of Miami acceptance on a per condition basis. At ground surface, use poured in place concrete pads, not precast splash blocks.
 - h. Paint downspouts to match adjacent wall color.
 - i. Solder lap joints. Sealant at joints is not allowed. Provide expansion joints for thermal expansion and contraction.
 - j. Provide strap reinforcement with hemmed edges and no sharp edges.

07 70 00 ROOF SPECIALTIES, ACCESSORIES, AND SKYLIGHTS

1. Roof Expansion Joints.
 - a. Comply with FBC High Velocity Hurricane Zones - Roof Coverings with Slopes less than 2:12.
 - b. Allow for expansion and contraction to minimize cracking and deterioration of building component materials.
 - c. Design and locate flexible, weather tight, and durable expansion joints to allow for movement and to relieve stresses.

- d. Roof expansion joints shall be compatible and according to the roofing manufacturer's specifications and recommendations.
 - e. Expansion joints shall be high profile.
2. Roof Scuttles.
- a. At new facilities, provide safe and secured access by scuttles or access doors to each flat roof if the roof deck or parapet exceeds 13 feet above adjacent finish grade or ground floor exterior slabs.
 - (1) Access, by scuttle or access door, is required to adjacent roofs if more than 42 inches above accessible roofs.
 - (2) Fixed external ladders are not allowed.
 - b. Locate roof scuttles, at least 30 inches wide by 54 inches long, over UM accepted means of roof access in mechanical rooms, electrical, custodial storage rooms, or other custodial controlled lockable spaces.
 - (1) See Division 5 for ladders.
 - (2) Coordinate with roof framing for unobstructed access.
 - c. Roof scuttles shall be connected to the building security system and have a hasp at the Interior.
3. Skylights.
- a. Skylights are not allowed.
 - b. Existing skylights shall be removed at re-roofing projects unless otherwise directed by UM. Provide and match existing structural deck and substrate.
 - c. See Division 05 - Metals for equipment framing supports and clearances.
4. Wood.
- a. Use one piece solid wood plates to secure coping to parapet walls.

07 81 00 Applied Fireproofing

Design Standards

1. The intent of these standards is to provide general guidelines on the design and provision for applied fireproofing. These standards shall not supersede code and regulations nor relieve the Architect and Structural Engineer for their professional responsibility.
2. Selection of applied fireproofing should be preceded by a careful analysis of applicable building codes, building regulations and authorities having jurisdiction. Select approved fire-resistance designs from Underwriters Laboratories (UL), based on the following types of applied fireproofing: cementitious fire-resistive materials and mastic or intumescent fire-resistive coating.
3. VOC content for Applied Waterproofing: 0.

Product Standards

1. Compliance with tested fire-resistance designs requires strict adherence to the materials and design details as indicated in UL's Fire Resistance Directory.
2. Specify products only after carefully considering each for its properties, tested performance, serviceability, and appearance, when exposed to view, and cost.
3. Specify cementitious fireproofing of density of not less than 15 lb/cu. ft for interior concealed air conditioned areas. Manufacturers: Cafco, W.R. Grace; Isolotex, Carboline.
4. Specify medium density Portland cement based cementitious fireproofing of not less than 22 lb/cu. Ft. for interior exposed air conditioned or non-air conditioned spaces where appearance is not important and where unexposed to human touch.
5. Specify high density Portland cement based cementitious fireproofing of not less than 40 lb/cu. Ft for exterior concealed and exposed fireproofing where appearance is not important and where not exposed to human touch.
6. The use of mineral-fiber is not allowed.
7. Specify mastic or intumescent fire-resistive coatings for interior and exterior exposed fireproofing where appearance is important and where exposed to human touch. This type of fireproofing can be finished to a smooth texture. Manufacturers: Albi-Clad; Carboline, Isolotex.

Performance Standards-Minimum

1. Indicate types and extent of fire-resistant assemblies and their corresponding fire-resistance design identifications on drawings; do not this information in the specifications.
2. Verify with fireproofing manufacturers if steel primer is allowed under fireproofing; verify compatibility of primer with fireproofing manufacturer if primer is required. Address this issue in the specifications regarding coordination with steel preparation, compatibility testing, etc.
3. For spaces above ceilings where space is used as air plenum may erode softer formulations of fireproofing. Consult with fireproofing manufacturers for their recommendations. Fireproofing in air plenums required flame-spread and smoke density indexes not exceeding 25 and 50 per NFPA 90A.
4. Architect to request the following submittals:
 - a. Product Data. Include VOC data.
 - b. Shop Drawings showing extent of each type of fire proofing, applicable fire-resistance U.L. design designations, thicknesses and treatment after application.
 - c. Qualification data from installer.

- d. Finish samples where appearance is important.
 - e. Mockup sample where appearance is important.
5. Require pre-installation conference at the site.
6. Applicator Qualifications:
- a. Applicator shall be qualified by a third-party qualification program established by UL. In addition applicator must be approved by fireproofing manufacturer, and have a minimum of five ten years experience applying specified fireproofing.

Field Quality Control

1. Manufacturer's field service: The Architect shall request the services of manufacturer technical representative to inspect the preparation and application of materials. The manufacturer's technical representative must visit the site before the installation, one visit during installation, and one visit after completion.
2. Require special inspections of applied fireproofing as mandated by the International Building Code. Require special inspections as mandated by local codes.
3. Testing to be performed by an independent qualified testing laboratory paid by Owner.

07 92 00 Joint Sealants

Design Standards

1. General:
 - a. This section contains the criteria for the design and materials selection of joint protection, including but not limited to joint sealants for traffic joints; non-traffic joints; mildew resistant and acoustical joints; latex sealant/caulking compounds; backer rods; sealant-filled foam strips; bond breaker tapes; and primers.
2. Joint Sealants:
 - a. Detail and specify the appropriate joint sealer and backing for the following interior and exterior conditions. For exterior vertical conditions use silicone sealant. For horizontal traffic and non-traffic joints, use urethane sealants. Refer to current manufacturers' sealant guide. Joint Sealant applications include but are not limited to:
 - (1) Joints in Vertical and horizontal surfaces.
 - (2) Vertical Expansion and Control Joints.
 - (3) Sealants exposed to physical abuse.
 - (4) Joints in Glass, ceramics, steel, aluminum and plastic applications.
 - (5) Joints in Precast panels joints; and joints between curtain walls and precast panels.
 - (6) Joints within Structural and non-structural glazing.

- (7) Traffic areas.
 - (8) Kitchen areas for vermin protection.
 - (9) Door and window openings at both exterior and interior locations.
 - (10) Joints in Tub and Shower enclosures, sinks, and countertops.
 - b. VOC content for Joint Sealants: 150 g/L or less.
 - c. Consider the joint dimension and expected movement to specify the proper sealant. Good architectural practice calls for joint design four times the anticipated movement due to construction tolerances and material variations
 - d. Consider if the application is for new construction or remedial/remodeling projects.
 - e. Compatibility: Provide joint sealers, joint fillers and other related materials that are compatible with one another and with joint substrates under conditions of service and application, as confirmed demonstrated by sealant manufacturer based on testing and field documented experience. Confirm with joint sealant manufacturers if primer is required/recommended on surfaces receiving joint sealant. Specifications to include requirement for following testing:
 - (1) Preconstruction Compatibility and Adhesion Testing performed by sealant manufacturer.
 - (2) Preconstruction Field-Adhesion Testing as recommended by sealant manufacturer
 - (3) Field Testing as recommended by sealant manufacturer.
3. Latex Joint Sealants/Caulking Compound:
- a. Use latex joint sealants/caulking for interior non-moving joints on and between field painted surfaces.
 - b. Use mildew resistant interior joint sealant products wherever humid conditions and high temperature exist.
 - c. Use latex acoustical sealant for exposed and concealed locations of acoustical joints.
4. Joint Backing:
- a. Provide backer rod joint filler in horizontal joints subject to foot and vehicular traffic, at a distance beneath slab surface of 1/2 the joint width. Sealant manufacturer's recommendations as to type of backer rod joint filler must be followed.
 - b. Joint backing shall be omitted from joints in ceramic tile floors, which are less than 1/2 inch deep if the joints are filled fully with sealant and if the sealant's manufacturer approves it. Provide backer rod in all other sealed joints at a depth that will permit application of sealant in an hourglass profile with a depth at neck 1/2 the joint width, but in no case more than 1/2 inch.
 - c. Whatever the joint size or substrate, provide backer rod or bond breaker tape as necessary at back of sealant to prevent bonding. Exceptions: Sawed concrete joints; items bedded in sealant such as thresholds.
 - d. Backer rod: Closed cell foam rope of polyethylene, butyl neoprene or other material that will not bond to sealant, 25 to 50 percent larger in diameter than joint width, unless otherwise recommended by sealant manufacturer.

5. Bond Breaker Tape:
 - a. Polyethylene type of widths to suit joints. Provide over joint fillers other than polyethylene type, unless otherwise recommended by sealant manufacturer.
6. Primers:
 - a. Include requirement for priming of surfaces based on manufacturer's preconstruction compatibility and adhesion testing. Primer type is to be as recommended by sealant manufacturer.
7. Applications:
 - a. The following guidelines address typical conditions where sealants and related components must be applied. The Architect shall complete the following non-all-inclusive list for each specific project:
 - (1) Joints Requiring Sealants:
 - (a) Joints around window frames, mullion ends, door frames and wall louvers.
 - (b) Exterior thresholds, front edges, rear edges and ends.
 - (c) Exterior and interior exposed and concealed joints between precast wall panel units and interior joints between backs of panels and concrete floor slabs at each level above first floor on fill.
 - (d) Exterior and interior wall and floor expansion joints including joints between concrete columns in concrete walls, between concrete columns and steel columns and between pre-finished metal wall panels and abutting materials.
 - (e) Outer perimeters of sheet metal scupper between sheet metal and masonry or concrete and between pre-finished sheet metal scuppers and metal wall panels.
 - (f) Joints at top of parapet cap flashings including lap joints in flashings.
 - (g) Joints at top of counter flashings including lap joints in flashings.
 - (h) Joints at top of pipe and conduit roof penetration counter flashings including lap joints.
 - (i) Joints at perimeters and splice joints for built-in gutters over pivoted glass panels.
 - (j) Metal-to-metal joints and metal to concrete joints in skylights.
 - (k) Joints between building walls and concrete walks and concrete paving. Joints in exposed concrete floors.
 - (l) Expansion joints, control joints, penetrations and perimeter joints in mechanical equipment room wearing slabs, patio slabs, and balcony slabs.
 - (m) Expansion joints at perimeter of ceramic floor tile areas and joints at interior corners in tiled wall and base areas.
 - (n) Perimeter joints at electrical and mechanical items penetrating walls, floors, ceilings and roofs.

- (o) Expansion joints in quarry tile and paver tile areas 12 feet to 16 feet o.c. both ways in field and at perimeter.
- (p) Expansion joints at all exposed decks and surfaces.
- (q) Joint at perimeter of flagpole.
- (r) Joints where Portland cement plaster/stucco and cement plaster abut other materials.
- (s) Joints between walk-in refrigerators, freezers, food service equipment and other building surfaces using sanitary, mildew resistant silicone type sealant.
- (t) Joints between sink and vanity countertops/backsplashes and other building surfaces. Joints in countertops. Use mildew resistant sealant.
- (u) Joints between walls and plumbing fixtures such as sinks, lavatories, urinals and prefabricated shower stalls, using mildew resistant sealant.
- (v) Joints around piping in shower stalls and bathtub areas, using mildew resistant sealant.
- (w) Bedding of metal accessories and fastenings in shower stalls and bathtub areas, using mildew resistant sealant.
- (x) Locations indicated on the drawings and where required to make joints weathertight.

(2) Joints Requiring Latex Joint Sealants/Caulking

- (a) Joints between interior hollow metal door and window frames and gypsum board, cement-plaster, masonry.
- (b) Non-moving non-traffic joints between painted interior surfaces.

8. Colors

- a. Select colors from standard manufacturer's color chart.

9. Manufacturer's technical services:

- a. Consider using the manufacturer's technical service centers:

- (1) To assist in selecting the proper building sealant, properly designed joints and review of joint sealant specification.
- (2) To assist in testing such as:
 - (a) Compatibility and adhesion tests.
 - (b) Preconstruction field adhesion test to determine preparation and installation methods.
 - (c) Stain tests to confirm that joint sealant will not stain surfaces to be sealed.
- (3) To assist in interpreting test results. To assist in product recommendations, surface preparation and primer.
- (4) To assist in reviewing shop drawings and other pertinent technical information.

Products Standards

1. Acceptable Manufacturers and Products:
 - a. Silicone Sealants-Vertical Joints:
 - (1) Dow Corning, 790, 791, 795 and 799 Silicone Building Sealant.
 - (2) General Electric Silicones, NB SCS9000, SCS2000, and UltraPruff II SCS2900.
 - (3) Pecora, 863, 890, 890FTS 895, 898.
 - (4) Sika, Sikasil-C995.
 - (5) Tremco Spectrem 2, Spectrem 3 and Proglaze.
 - b. Silicone Mildew Resistant Sealants-Vertical Joints and Non-Traffic Horizontal Joints:
 - (1) Dow Corning, 786 Mildew Resistant.
 - (2) Pecora 898.
 - (3) General Electric Silicones, SCS1700.
 - (4) Tremco Tremsil 200 Sanitary.
 - c. Urethane Sealants for Traffic Joints:
 - (1) Tremco, Vulkem 921, Vulkem 45, 116 or 227. Dymeric 240FC.
 - (2) Pecora, Urexpan NR-201 and Dynatred.
 - (3) Sika, Sikaflex 1a and Sikaflex 1CSL.
 - d. Urethane Sealants for Immersible Traffic Joints:
 - (1) Tremco, Vulkem 45, 245, 116 and 227.
 - (2) Sika, Sikaflex – 1CSL.
 - e. Latex Joint Sealants/Caulking Compound
 - (1) Pecora Corporation; AC-20+.
 - (2) Tremco; Tremflex 834.
 - f. Latex Acoustical Joint Sealants
 - (1) Pecora Corporation; AC-20 FTR Acoustical and Insulation Sealant.
 - (2) United States Gypsum Co.; SHEETROCK Acoustical Sealant.
 - (3) Tremco; Tremco Acoustical Sealant.

Performance Standards

1. Applicator/Installer Qualifications: The Architect shall require:
 - a. An affidavit from the manufacturer approving applicator prior to installation.
 - b. Applicator shall have a minimum five years documented experience installing specified joint sealants and shall have successfully completed at least five projects of similar size and complexity.
2. Contractor Submittal requirements:
 - a. Submit for project records, sealant manufacturer's letter stating that substrates are acceptable, have been reviewed with the applicator; indicate if primers are required and if so the types of primers required for the various surfaces.
 - b. Submit for review, properly identified manufacturer's product data, with names, catalog numbers, specifications, surface preparation, primers required for each different type of surface, mixing and application directions for each product.
 - c. LEED requirements, including VOC contents.
 - d. Samples

- (1) Sealant manufacturer's full color range charts for selection by Architect and approval by UM.
 - (2) Small samples of each type of joint backing rod, sealant and bond breaker tape.
3. Preparation and Limitations: Per sealant manufacturer's recommendations.
4. Application of Sealants
 - a. Sealant Installation Standard: Comply with recommendations of ASTM C1193 for use of joint sealants as applicable to materials, applications, and conditions indicated.
5. Field Testing
 - a. Water infiltration test will be performed, at the owner's option, at every exterior joint including but not limited to: window, storefront and curtain wall.
6. Warranty
 - a. Be aware that some warranties will require prior inspection and testing. Review warranties with manufacturer before preparing specifications.
 - b. Silicone Sealants:
 - (1) 10 years manufacturer's written warranty.
 - c. Urethane Sealants:
 - (1) 5 years manufacturer's written warranty.
 - d. Applicator/Installer: 2-year warranty covering sealant materials and workmanship covering joint failure should be required. Joint failure is defined as: Leaks of air or water; evidence of loss of cohesion; cracking or splitting; fading of sealant material; migration of sealant; evidence of loss of adhesion between sealant and joint edge. The sealant manufacturer and the sealant applicator shall sign this warranty.

07 95 00 Expansion Control

Design Standards

1. General:

This section contains the criteria for the design and materials selection of building expansion joint covers, including building expansion joint covers for interior and exterior application. Roof expansion joints are not part of this portion of standards.
2. Expansion Control Systems/Joint Covers
 - a. Detail and specify the appropriate joint cover and backing material.
 - b. Characteristics and locations of expansion control systems/joint covers are determined by the structural engineer in consultation with the Architect.
 - (1) Location, size and movement characteristics of expansion joints are of key importance in the selection of expansion control systems/joint covers.
 - c. Fire resistant rated expansion control systems are required by building code in fire-rated construction. Most expansion covers can be fire rated by addition of fire barrier.

- d. Exterior expansion covers must be provided with a watertight seal.
 - e. Design parking structures requiring joint covers so that joints are located away from turning lanes, break overs, and acceleration areas. Verify with UM anticipated speed, weight of anticipated vehicles and loading requirements. Confirm with system manufacturer if selected system meets project requirements. Information/recommendations from manufacturers must be submitted in writing.
 - f. Obtain expansion control systems from single source from single manufacturer.
3. Manufacturer's technical services:
- a. Consider using the manufacturer's technical service centers to assist in selecting the proper building expansion control system/joint covers.

Products Standards

1. Specify products only after carefully considering each for its characteristics to accommodate contraction and expansion, joint width, load capacity, fire rating and water-tightness where required.
2. Joint Cover Materials/Types for Interior Application:
 - a. Floors: Flush mounted floor systems fabricated with extruded Aluminum Covers, mill finish; other finishes and types must be approved by UM.
 - b. Walls and Ceilings:
 - (1) Extruded Aluminum Cover Plate System, anodized or baked enamel finish. Color as selected by Architect.
 - (2) Elastomeric extrusions of color as selected by Architect.
 - c. Provide fire resistance-rated joint covers in fire rated construction. As tested per UL 2079 and ASTM E1966
 - d. Manufacturers: Construction Specialties and MM Systems.
3. Joint Cover System for Parking Expansion Covers
 - a. Specify system that supports moving vehicle loads, provides smooth walking surfaces for pedestrians, resists damage from dirt, environment exposure and function in weather extremes. The use of rubber pad systems is preferred.
 - b. Manufacturer: Watson Bowman Acme Corp., and MM Systems
 - c. Use moisture barriers /gutter systems under joint cover o.
4. Joint Cover Systems for Open Air Expansion Covers
 - a. Slabs/Floors: Specify systems that can provide smooth walking surfaces for pedestrian, withstand environment exposure, resist damage from dirt and function in weather extremes. Select from Aluminum plate systems, mill finish, similar to interior but for heavy duty use and with moisture barrier.
 - b. Manufacturers: Construction Specialties, MM Systems.

- c. Exterior Walls and Soffits: Specify vertical cover plate system or flat seal system, subject to UM approval. Provide moisture barrier behind/under cover. Use Fire barrier where required by conditions. Manufacturers: Construction Specialties and MM Systems.
5. Fasteners
- a. For exterior application specify Type 316 stainless steel.
 - b. For interior application specify Type 304 stainless steel.

Performance Standards

- 1. Installer Qualifications: The Architect shall require:
 - a. An affidavit from the manufacturer certifying applicator prior to installation.
 - b. Applicator shall have a minimum five years documented experience installing specified expansion control covers and shall have successfully completed at least five projects of similar size and complexity.
- 2. Contractor Submittal requirements:
 - a. Submit for review, properly identified manufacturer's product data, with names, catalog numbers, specifications, and surface preparation.
 - b. Shop drawings for each required expansion control cover. Show finishes, installation directions, changes in direction, installation instructions. Indicate where fire resistive rating is required; indicate compliance with UL2079 and ASTM E1966. Indicate moisture barrier. Require that shop drawings be prepared by manufacturer of expansion control cover.
 - c. Request samples of exposed finishes including but not limited to metal, extruded elastomeric seals and gaskets, exposed fasteners.

DIVISION 08 OPENINGS

This chapter identifies criteria for the design of both interior and exterior openings in UM buildings with the purpose of establishing minimum standards, acceptable to UM, to be used as the basis of design for UM Coral Gables Campus. Both exterior and interior systems and products must provide as needed a secure, safe, egress, light and ventilation system as required in order to provide a weather tight, thermally efficient work environment for the occupants in a sustainable and reliable design.

- 08.1 General Requirements
 - 08.1.1 Submittals
 - 08.1.2 Workmanship requirements
- 08.2 Codes and Standards
- 08.3 Design Criteria
- 08.4 Specific Requirements (organized by CSI MasterFormat® 2012 Numbers & Titles)

08.1 General Requirements

UM Coral Gables Campus and UM Buildings openings must be designed to comply with the following objectives:

1. Weatherproof impact resistant exterior openings.
2. Sustainable Design, using sustainable products.
3. Ease of maintenance.
4. Safety and security with safety concerns always having a priority over security.
5. Solutions with the best value considering a life cycle cost analysis to account for total project cost.
6. Compliance with State of Florida and/or Miami-Dade County Product Approval (NOA) data for all exterior doors and openings including louvers.
7. Hurricane (High Velocity Wind Zone) Resistance and Impact Resistance.
8. Fire resistance rating for doors, windows and other opening protective that comply with the current requirements of the Florida Building Code.

The design of the interior and exterior openings, in concert with other building components, shall produce a building that meets the programmed sustainability rating (LEED rating) of the specific project.

08.1.1 Submittals

Submittals shall include product data, samples, sustainability data, shop drawings, certificates and design analysis, which are to be coordinated with all corresponding disciplines. The design professional shall prior to the acceptance by UM of the final submittal by the Owner. The design professional shall consult with the UM Facilities Operation Maintenance Department to identify locations to receive access control systems, motion detectors and other security measures.

08.1.2 Workmanship requirements

Refer to specific requirements included herein.

08.2 Codes and Standards

1. Florida Building Code (FBC).
2. The City of Coral Gables local codes and ordinances.

08.4 Specific Requirements (Organized by CSI MasterFormat® 2012 Numbers & Titles).

08 10 00	Doors and Frames
08 11 13	Hollow Metal Doors and Frames
08 14 16	Flush Wood Doors
08 41 13	Aluminum Framed Entrances and Storefronts
08 41 26	All Glass Entrances and Storefronts
08 44 13	Glazed Aluminum Curtain Walls
08 51 13	Aluminum Windows
08 71 00	Door Hardware
08 80 00	Glazing
08 83 00	Mirrors
08 91 19	Wall Louvers

08 10 00 Doors and Frames

Design Standards

1. General:
This section provides guidelines for the selection of exterior and interior doors and frames.
2. General application shall be as follows, unless otherwise noted in project specific requirements:

	Door Type	Frame Type	Remarks
Office	Solid core wood – Single	H.M. frame	Interior door
Classroom	Hollow Metal – Single	H.M. frame	Exterior or Interior Doors
Lab	Hollow Metal – Single	H.M. frame	Exterior or Interior Doors
Mechanical Room	Hollow Metal – Double	H.M. frame	Exterior or Interior Doors
Electrical/Telecom Room	Hollow Metal – Single	H.M. frame	Exterior or Interior Doors
Main Entrances	Aluminum Framed Entrances	Aluminum framed storefront framing	Exterior Entrances

3. Provide door schedules for new or relocated doors affected by scope of work. Locate Door Schedule on the drawings and include the following.
 - a. Door numbers.
 - b. Room numbers or space to be secured.
 - c. Width, height, and thickness of door.
 - d. Type of center mullion, if applicable.
 - e. Door type referenced to door elevations.
 - f. Door material.
 - g. Frame type.
 - h. Frame material.
 - i. Reference to jamb, head, and threshold details.
 - j. Fire rating label where applicable.
 - k. Door Hardware set number as it appears in door hardware schedule.
 - l. Reference to Card access control if applicable.
 - m. Reference to electrified hardware preparation if applicable.
 - n. Reference to Power Assist Door Operator if applicable.
4. Card Reader Access – Coordinate with electrical drawings and Project Manual/specification for electrical requirements at specific locations.
5. All exterior doors and frames shall be designed to resist wind loads per Florida Building Code for High Velocity Hurricane Zones. Coordinate requirements of exterior door hardware with State of Florida Building Code Product Approval or Miami-Dade N.O.A. for High Velocity Wind Zones (HVWZ).
6. Doors are subject to vandalism and heavy usage. The Architect shall consider the location and intended use of each door before its selection.
7. Doors that are components of the means of egress shall comply with applicable all Life Safety Codes.
8. Fire resistance ratings for exterior doors, shall meet the applicable fire separation requirements between buildings, pertaining to walls facing each other. Interior doors/frames located in fire/smoke rated assemblies shall provide the required rating to ensure the integrity of the entire assembly and an effective compartmentalization.
9. Provide maneuvering clearances at doors to comply with accessibility requirements, and other guidelines of the ADA-ABA Accessibility Guidelines and the Florida Accessibility Code for Building Construction.
10. Doors shall swing in the direction of the exit travel, unless they are located at spaces with a lower occupant load as permitted by code.
11. Doors opening into corridors or traffic patterns shall be recessed and not project into the corridor or traffic pattern, except at mechanical rooms, custodial closets, and other service spaces with low traffic.
12. Provide fin walls at multiple pairs of doors to prevent interference at door swings during operation, or locate doors to avoid interference.

13. All exterior doors shall be recessed or have a protective canopy, roof or eyebrow.
14. Particleboard is not allowed in wood door construction. Use wood doors in interior applications only.
15. All metal door frames in masonry walls and partitions shall be grout filled. Interior metal door frames in gypsum board partitions shall be filled with fiberglass or wool fiber insulation.
16. Sizes and Thickness: Typical size: 3'-0" wide x 7'-0" high; thickness: 1 3/4" thick, unless otherwise noted in specific application requirements. Wider doors are allowed to accommodate egress or equipment requirements.
17. Acoustical requirements: Doors requiring sound proofing over 38 STC shall be selected from manufacturer that provides door, frame and sound seals as a system.
18. Access doors shall be typically at least 12 inches by 12 inches for hand access. Coordinate with engineers for size requirements and locations.
19. Dutch doors: Provide per program requirements.
20. Center Mullions: Interior or exterior pair of doors require fixed or removable steel center mullion, except at specific doors as required by the program, mechanical rooms and storage rooms. Permanent center mullions shall be grout filled in place and securely anchored.
21. View Panels: Provide view panels at entrance doors according to program requirements. For security purposes, view panels shall not allow interior locking devices to be visible from the exterior.
 - a. View Panels at fire rated doors shall be glazed with fire rated glazing. Wire glass is not allowed.
 - b. Consult with UM the use of laminated security glazing over view panels at high security areas.
 - c. View Panels at acoustical doors shall be double glazed.
22. Viewports: Provide viewports (peepholes), in accordance with program requirements, e.g. at computer doors, kitchen doors, etc. Consult with the UMBS Committee.
23. The allowed width of clear glazing for continuously glazed door sidelights is not less than 8 inches and not more than 18 inches.
24. Before final design submittal, the Architect shall consult with the following:
 - a. UMPD for the locations of card access control systems, motion detectors, and other security issues.
 - b. UM Facilities Management for card access control systems and other specific hardware requirements.

08 11 13 Hollow Metal Doors and Frames**Design Standards**

1. This section provides general guidelines for hollow metal doors and frames.
2. Select exterior doors and frames that have Miami-Dade NOA Large Missile Impact Rating.
3. Installers must be authorized, certified, or licensed by door and frame manufacturer.
4. Coordination with door hardware is of utmost importance.

Product Standards

1. Materials:
 - a. Exterior Doors and Frames: Metallic Coated Steel Sheet, G60.
 - b. Interior Doors and Frames: Cold-rolled steel sheet, unless metallic coated steel sheet is required due to corrosive environment.
2. Door Types: Doors must be seamless fully welded construction. Drawings to include details and profiles.
 - a. Exterior Entrance and Exit Doors shall be fabricated in accordance with ANSI/SDI- A250.8. Level 4 Maximum Duty, Model 2 seamless. Exterior doors other than public entrance and exit doors shall be fabricated in accordance with ANSI/SDI-A250.8, Level 3, Extra Heavy Duty, Model 2, seamless.
 - b. Interior Doors shall be fabricated in accordance with ANSI/SDI-A250.8, Level 3 Extra Heavy Duty, Model 2, and Seamless.
 - c. Provide view panels, louvers etc., in accordance with program requirements.
 - d. Face Sheet Thickness:
 - (1) Level 3 Doors: 0.053 (16 gage) thick.
 - (2) Level 4 Doors: 0.067 inch (14 gage) thick
 - e. Door Perimeters: 16-gage steel channels to reinforce stile edges, top and bottom of doors. Same finish as door.
 - f. Door Stiffeners: Vertical 20 gage steel channels members spaced not more than 6 inch o.c.
 - g. Core Fill: For exterior doors provide core fill in accordance with Miami-Dade NOA. Interior doors core optional with manufacturer.
 - h. Reinforcements and Hardware Provisions: Doors shall be mortised and shall be drilled-tapped for mortised hardware per ANSI/SDI A250.6 recommendations; coordination between door hardware trade and door and frame trades must be required during shop drawing phase.
 - i. Door lights in metal doors: 18-gage bonderized zinc coated sheet steel channel light frames and stops.
 - j. Door Louvers:
 - (1) In general, the use of inverted "Y" blade is encouraged, except where additional free airflow louvers or lightproof louvers are required. At exterior areas, consider probable water penetration.
 - (2) Fire door louvers: UL listed sheet steel frame, fusible link and lever operating mechanism enclosure, and movable blades, 24" maximum dimension in height or width. Same finish as door.

- k. Astragals: For pairs of single acting doors without center mullions, provide a continuous flat steel bar, same finish as door.
 - l. Screens: Where louvers are indicated on exterior doors, call for vermin screen fabricated from stainless steel with frame mounted on interior side of door.
3. Hollow Metal Frames:
- a. Request compliance with ANSI/SDI A250.8. Drawings to include details of types and profiles.
 - b. Thicknesses Gages:
 - (1) Frames for Level 3 Steel Doors: 0.053-inch- (16 gage) thick steel sheet.
 - (2) Frames for Level 4 Steel Doors: 0.067-inch- (14 gage) thick steel sheet.
4. Fabrication: Specify that frames be full profile welded construction with mitered head and jamb members with integral stops. Corners shall have continuous welds ground flush and smooth without dishing. Design professional shall specify the requirements for special frames and special conditions, if any. Knock down frames are not allowed. Hollow metal side lights and borrowed lights should have same construction and be included as part of this section.
5. Reinforcement and Hardware Provisions: Same applicable standard as for doors.
6. Silencer Provisions for Interior Doors: Call for three silencers at single door frame and for one silencer for each leaf at double door frames.
7. Grout Guards: Call for sheet metal covers welded in back of frames at hinges, locks, bolts and tapped reinforcements at hardware. At silencer locations furnish suitable removable plugs in holes to keep grout free. Provide only at grout filled frames.
8. Factory Finishing For Steel Doors and Frames.
Shop coat of manufacturer's standard rust-inhibitive metal primer, baked on.
9. Manufacturers of H.M. Doors and Frames:
Require that doors and frames be provided by same manufacturer. The following manufacturers are acceptable subject to compliance with the Criteria provided in these standards:
- a. Firedoor Corp.
 - b. Pioneer Industries.
 - c. Curries
 - d. Ceco Door Products.
 - e. Windsor/Republic Door
 - f. Steelcraft
 - g. Habersham

Performance Standards

- 1. Specify compliance with ANSI/SDIA250.8 for standard hollow metal doors and frames.
- 2. For exterior doors and frames specify that listed manufacturers have Miami Dade NOA for Large missile impact rating. Make sure weather-stripping and thresholds for exterior doors are addressed in Door Hardware section.

3. Specify that Fire rated Door Assemblies: Units must comply with NFPA 80 and must be labeled and listed by UL, Factory Mutual or Warnock Hersey.
4. On large projects, call for pre-installation conference at the job site.
5. Hollow metal doors are frames are generally provided with a factory shop primer. Factory finish is available and may be specified subject to UMBS Committee approval.
6. Submittals required from Contractor:
 - a. Product Data, LEED data and Miami Dade NOA Large missile impact rating data.
 - b. Shop drawings indicating sizes, elevations, locations, fire labels, construction details, gages, thicknesses, finishes, reinforcement, anchors, louvers, light openings, glazing stops and hardware locations. Request that shop drawings be coordinated with Door Hardware Specification Section and Door Schedule on drawings.
 - c. Shop drawings must indicate coordination with the following trades:
 - (1) Door hardware supplier.
 - (2) Electrical work.
 - (3) Card Access System.
 - (4) Power Assist Door Handicapped operator.
 - (5) Door preparation required to receive above items.

08 14 16 Flush Wood Doors

Design Standards

1. This section provides guidelines for the design of interior flush wood doors. This section also includes guidelines for submittals to be requested from contractor.
 - a. Properly address emissions and limitations of volatile organic compounds (VOCs). Adhesives and composite wood products containing urea-formaldehyde are prohibited from use.
2. Environmental Limitations:

Specifications to include requirement that wood doors not be delivered or installed until building is enclosed, wet work is complete, and HVAC system is operating and maintaining temperature and relative humidity at occupancy levels during the remainder of the construction period.
4. Source Limitations:

Specifications to include requirement to engage a qualified woodworking firm to assume undivided responsibility for production of architectural wood cabinets, wood paneling, and transparent-finished wood veneered doors that are required to have sequence-matched wood veneers.

5. Wood Species and Cut:
For transparent finish wood, wood and wood veneers shall be either Maple or Birch, plain cut, book matched.
 - a. Veneers must be FSC US certified. Foreign species are not allowed.
 - b. Exposed vertical and top edges are to be of the same species as the faces.
 - c. Deviation from this guideline requires UMBS Committee approval.

6. Veneered-Faced Doors for Transparent Finish
 - a. Interior Solid Core-Doors Veneer Criteria:
 - b. Grade: Premium, with Grade AA faces.
 - c. Species: As indicated on drawings.
 - d. Cut: As indicated by the Design Professional
 - e. Match between Veneer Leaves: Book match.
 - f. Assembly of Veneer Leaves on Door Faces: Center-balance match.
 - g. Pair and Set Match: Provide for doors hung in same opening or separated only by mullions.
 - h. Room Match: Match door faces within each separate room or area of building.
 - i. Blueprint Match: Where indicated, provide doors with faces produced from same flitches as adjacent wood paneling and arranged to provide blueprint match with wood paneling.
 - j. Exposed Vertical Edges: Same species as faces.
 - k. Core: Solid Core.
Construction: Five plies. Stiles and rails are bonded to core, and then entire unit abrasive planed before veneering. Faces are bonded to core using a hot press.

Product Standards

1. General:
 - a. Fabricate doors with adhesives and composite wood products that do not contain urea formaldehyde.
 - b. Specify that wood doors be produced from wood obtained from forests certified by an FSC-accredited body to comply with FSC STD-01-001, "FSC Principles and Criteria for Forest Stewardship," and FSC STD-40-004, "FSC Standard for Chain of Custody Certification.
 - c. Use wood doors for interior application only.

2. Solid Core Wood Doors:
 - a. Core: Staved lumber core.
 - b. Quality Standard: In addition to requirements specified, comply with AWS "Architectural Woodwork Standards "Flush Doors," and WDMA I.S.1-A, "Architectural Wood Flush Doors."
 - c. Construction: 5-ply construction, AWS Section 9 Premium Grade, SLG-5.
 - d. Performance Duty: AWS Extra Heavy Duty Level and WDMA I.S.1-A, "Architectural Wood Flush Doors" Extra Heavy Duty Performance level.
 - e. Face Veneers: Wood species; cut and sequence to be selected from listed species, subject to UMBS Committee approval.
 - f. Vertical Meeting Edge: Rabbeted.
 - g. Horizontal Meeting Edge: Rabbeted.
 - h. Dutch Door: Rabbeted with side shelf.

3. Fire Rated Wood Doors:
 - a. U.L. Labeled doors with labels attached, 1-3/4 inch thick. Provide wood blocking with improved screw-holding capability approved for use in fire-rated doors as necessary to eliminate need for thru-bolting hardware.
 - b. Construction: 5-ply, AWS Section 9, premium grade FD-5.
 - c. Performance duty: same as specified above under non-rated doors.
 - d. Core: Non-combustible mineral sections.
 - e. Face Veneer: Wood species, cut and sequence to be selected from listed species, subject to UMBS Committee approval.
4. Require that wood doors be factory finished as follows:
 - a. Transparent Finish Doors: Factory finished in accordance with requirements of AWS, Section 5, Premium System 11 catalyzed polyurethane satin sheen finish. Specify staining if required.
 - b. Opaque Finish Doors: Factory finished in accordance with requirements of AWS, Section 5; Premium System 11 catalyzed polyurethane satin sheen finish. Specify color.
5. Manufacturers of Wood Doors:

The following manufacturers are acceptable subject to compliance with Criteria:

 - a. Eggers Industries.
 - b. Algoma Hardwood Inc.
 - c. Buell Door Co.
 - d. Marshfield Door Systems, Inc.
 - e. VT Industries, Inc.

Performance Standards

1. Submittals required from contractor:
 - a. Product Data and samples of wood veneers with finish applied.
 - b. Shop drawings for review, indicating sizes, elevations, locations, fire labels, construction details, gages, thicknesses, finishes, reinforcement, anchors, louvers, light openings, glazing stops and hardware locations. Request that shop drawings be coordinated with door hardware specification section and drawings. Shop drawing should also show coordination with the following trades:
 - (1) Electrical work.
 - (2) Card Access System.
 - (3) Power Assist Door operator.
 - (4) Door preparation required to receive above items.
 - c. Samples for factory finished doors.
 - d. Samples of veneer flitches for transparent finish doors
2. Fire rated Door Assemblies: Units must comply with NFPA 80 and must be labeled and listed by UL, Factory Mutual or Warnock Hersey.

Warranty: Interior wood doors to carry lifetime warranty by door manufacturer. The warranty shall include veneer delamination and warping.

**08 41 13 Aluminum Framed Entrances and Storefronts and
08 44 13 Glazed Aluminum Curtain Walls****Design Standards**

1. This section provides the guidelines for the selection, design, and installation of aluminum entrances and storefront assemblies. It also provides guidelines for Glazed Aluminum Curtain Walls. Storefront assemblies and glazed aluminum curtain wall systems are sometimes produced by the same manufacturer however more stringent requirements are used in curtain wall designs. Refer to Miami-Dade NOA for maximum sizes on storefront units and curtain wall units. Consider not mixing storefront framing and curtain wall framing in a project. If project requires this condition, seek UMBS Committee approval before proceeding with design.
2. Provide aluminum framed entrances, storefront systems and glazed aluminum curtain walls that comply with structural performance, air infiltration and water penetration requirements required by building code, local code and Miami-Dade NOA Large missile impact rating test.
3. Ensure that the assemblies include options such as hardware, door controls, and threshold heights that comply with applicable provisions in the ADA/ABA Accessibility Guidelines and the Florida Accessibility Code.
4. Select and specify systems that have passed large missile impact testing with current Miami-Dade County Notice of Acceptance (NOA) or current Florida Building Code Product Approval. Base entrance hardware on NOA approval list.
5. In general, use medium stile entrance framing. For interior doors, provide 5 inch medium vertical stile, 5 inch medium top rail, and 10 inch bottom rail. Narrow stile is not permitted. Wide stile requires approval by the UMBS Committee.
6. Determine if the use of thermal entrances or thermal systems is appropriate to the specific condition, and if it is required to meet the energy analysis. UMBS Committee approval is required.
7. The use of special doors, frames, or storefront systems, such as frameless doors, automatic sliding glass doors, etc., shall be approved by UMBS Committee.
8. Depending on the application, the use of swinging single acting doors is preferable.
9. Exterior Glazing shall be either Laminated Glass or Insulated Laminated Glass; refer to Section 088000. Glazing shall be specified depending on energy study and program requirements.
10. Air Infiltration: Per Miami-Dade County NOA or Florida Building Code Product Approval.
11. Water Penetration: Per Miami-Dade County NOA or Florida Building Code Product Approval.

12. Aluminum Entrance Doors
 - a. Style and thickness: All stiles shall be a medium 6-1/2 inch wide bottom rail; 1-3/4 inches thick, minimum.
 - b. Material and Construction: Extruded 6063-T5 aluminum alloy sections, minimum 0.125 inch thick; corners to be both welded and mechanically fastened. Welded corner joinery shall be specified to meet warranty requirements.
 - c. Edges:
 - (1) Pair of Doors - Rounded meeting stile edges with dovetail provisions for retaining weathers tripping.
 - (2) Single-Acting Swinging Doors - Beveled jamb edge stiles.
 - d. Weather stripping: Manufacturer's weather stripping for exterior application.
13. Fastenings: Fabricated from Type 316 stainless steel. Request concealed fasteners.
14. Closers: All closers for aluminum doors shall be surface mounted.
14. Door Hardware: Select door hardware from options included in Miami Dade County NOA. Coordinate with Facilities Management Design & Construction. In all cases, provide concealed closers.

Product Standards

1. Approved Manufacturers:
 - a. Refer to attached Appendix "A".
2. Approved Finishes:
 - a. High Performance Organic Coatings:
 - (1) 2-coat fluoropolymer finish complying with AAMA 2605 and containing not less than 70 percent PVDF resin by weight in color coat. Provide clear top coat over color coat at aluminum entrance doors.
 - (2) Color: White or Green to match UM samples. Provide uniform finish and color throughout. Finishes other than listed require UM approval.
 - (3) Confirm that system manufacturer/finish manufacturer can provide a 20 year finish warranty.
 - (4) In some existing buildings, finish may need to match an anodized finish; consult with the UMBS Committee before specifying finish.

Performance Standards

1. Submittals Required from General Contractor:
 - a. Product Approval data from Florida Building Code or Miami-Dade County demonstrating large missile impact testing data.
 - b. Samples of the following:
 - (1) 12 inch long aluminum sample with specified finish. Provide sample with clear coating over color coating as well as sample with color coating only.
 - (2) Sealant, including color to match aluminum.
 - (3) Glazing gaskets.
 - (4) Weather stripping.

- c. Shop drawings showing materials, sizes, thickness, locations, construction details, frame reinforcing, glazing details, accessories and erection details. Wind load and deflection calculations, signed and sealed by a Professional Structural Engineer registered in the State of Florida.
 - d. Installer Qualifications.
 - e. Copy of warranties.
 - f. LEED submittals.
 - g. Mock up samples.
2. Installation
 - a. Request to separate aluminum and other corrodible metal surfaces from sources of corrosion or electrolytic action at points of contact with other materials.
 - b. Require that doors be factory mortised, reinforced, drilled and tapped to receive required hardware.
 3. Warranties:
 - a. Request 20 year warranty on aluminum finish. Request five year manufacturer's warranty on framing components.
 4. Field Testing
 - a. Request field inspection by manufacturer of system.
 - b. Request testing by a qualified independent testing and inspecting agency to perform field tests and inspections.
 - c. As a minimum request Water Spray Test on Storefronts and Glazed Curtain Wall Systems according to AAMA 501.2.

08 41 26 All Glass Entrances and Storefronts

Design Standards

1. This section provides guidelines for the selection, design, and installation of all glass entrances and storefront assemblies.
2. Use these assemblies for interior application only. UMBS Committee approval is required for these assemblies.
3. The Design Professional shall ensure that the assemblies include options such as hardware and fittings.
4. Show compliance with ADA/ABA Accessibility Guidelines and the Florida Accessibility Code on all-glass entrance doors.
5. Glass fittings style and finish require approval by UM. Finish requires approval by approval
6. Selection of entrance door hardware requires approval by the UMBS Committee Call for stainless steel 630 finish.

7. Depending on the application, the use of single acting doors is preferable.
8. Use tempered clear glass; minimum ½ inch thick. Glazing thickness to be determined by manufacturer of system.
9. Call for Installation to be performed by manufacturer or his authorized representative.
10. On “all glass walls,” “all glass doors,” “all glass sidelights,” alert the public that they are approaching glass a surface and not an open space by partially sandblasting, etching or other means that provides a translucent or patterned glass surface. Selected warning method requires approval. The allowed clear glass width of continuously glazed door sidelights is not less than 8 inches and not more than 18 inches.

Product Standards

1. Approved Manufacturers:
 - a. Blumcraft of Pittsburgh.
 - b. Oldcastle BuildingEnvelope, Inc.
 - c. Virginia Glass Products.
2. Approved Finishes:
 - a. Aluminum: Clear Anodic Finish, AAMA 611, AA-M12C22A41, Class I.
 - b. Stainless steel: Directional satin #4 finish. Stainless steel cladding over aluminum is acceptable, but needs approval by the UMBS Committee.
3. Glass: Clear tempered glass. Thickness to be determined by qualified professional engineer hired by contractor.

Performance Standards

1. Submittals Requirements from Contractor:
 - a. Product data from manufacturer, including door hardware and fittings.
 - b. Samples of the following:
 - (1) 6 inch long sample of each type of fitting of aluminum with specified finish.
 - (2) Sealant, including color to match aluminum.
 - (3) Glazing gaskets.
 - (4) Door pull/pull.
 - c. Shop drawings showing materials, sizes, thickness, locations, construction details, frame reinforcing, glazing details, accessories, each type of hardware and erection details. Include
 - d. Delegated-design submittal, signed and sealed by the qualified professional engineer responsible for their preparation
 - e. Installer Qualifications.
 - f. Copy of warranties.
 - g. Mock up samples if deemed necessary for large projects.
 - h. Maintenance data.

2. Installation
 - a. Request to separate corrodible metal surfaces from sources of corrosion or electrolytic action at points of contact with other materials.
3. Warranties:
 - a. Request 2 year manufacturer warranty on material and labor required to replace defective work. Request ten year manufacturer's warranty on concealed closers.
4. Field Quality Control
 - a. Request field inspection by manufacturer of system.
 - b. Field Testing: Test closers for compliance with accessibility to people with disabilities.
 - c. Test locking mechanism, exit devices, door swing.

08 51 13 Aluminum Windows

Design Standards

1. This section provides guidelines for the materials selection and design of aluminum windows for exterior and interior applications.
2. Consider using storefronts or curtain wall in lieu of fixed punched windows in order to keep same framing profile.
3. Show on drawings exterior windows that will be designated as elements of means of egress to comply with Life Safety Code NFPA 101.
4. Windows are subject to vandalism and heavy usage. Safety, security, and required maintenance are important criteria for designing and specifying windows. Safety concerns shall always have priority over security and maintenance during the selection of windows.
5. UMBS Committee encourages the maximum use of windows to provide natural light and, where required, ventilation into instructional/residential spaces, unless prohibited by program requirements or budget constraints.
6. Fire resistance rated exterior and interior windows shall have steel frames and shall meet Florida Building Code, NFPA 101 and NFPA 80 requirements.
7. Exterior windows and attachment/support systems shall be designed to withstand wind loads per Florida Building Code. Windows shall comply with ANSI/AAMA 101. The window glazing shall be laminated glass or insulated laminated glass as specified in glazing portion of these guidelines and as required to comply with Florida Building Code Requirements for High Velocity Hurricane Zones requirements.
 - a. New windows or replacement of existing windows shall be designed to resist the large missile impact criteria.

- b. Specify glazed window manufacturers that have passed large missile impact testing with current Miami-Dade County Notice of Acceptance (NOA) or current Florida Building Code Product Approval.
8. Comply with applicable codes for the required amount of operable window areas and as directed by program requirements.
9. Accessibility requirements do not apply to normal window operation, but do apply to exiting through emergency rescue openings. Refer to the Florida Accessibility Code for Building Construction (FACBC) for requirements applicable to emergency rescue openings.
10. Selection of window types shall be based on design intent, wall/window conditions, sustainable design requirements, security, use, safety, and maintenance concerns. Before final design submittal, the Design Professional shall consult with UMPD and Maintenance.
11. Discuss Security concerns with UMPD. Review program requirements.
 - a. At exterior operable windows and interior operable windows indicate single-hung or double-hung type windows. Casement or projected type windows require UMBS Committee approval.
12. Interior Fixed Windows:
 - a. Provide fixed aluminum windows with ¼ inch thick minimum clear tempered glass at non-fire rated areas.
 - b. The use of steel windows is limited to windows requiring fire rating. Provide fire rated clear glazing; the use of wire glass is not allowed.
 - c. For pass thru windows use horizontal sliding windows, except use fixed windows with speaker hole and pass thru tray at transom windows. Call for these windows to be fabricated from aluminum with clear anodized aluminum, or stainless steel with satin finish. Where shelving is required, coordinate the selection of materials with the UMBS Committee.
13. Storage rooms, telephone and electric closets, mechanical equipment rooms, new toilet rooms, custodial closets and other similar spaces shall be windowless.
14. Fasteners: Fabricated from Type 316 stainless steel at exterior locations, Type 304 stainless steel at interior locations.
15. Window Hardware:
 - a. Hardware shall be non-removable or secured by concealed or tamperproof fasteners. Check with the UMBS Committee for special locking requirements.
 - b. Exposed fasteners, when the window is in a closed or opened position, shall be tamperproof; fasteners must be fabricated from stainless steel. Exposed fasteners and hardware shall match finish of adjoining metal.
 - c. For operable windows, require automatic sill locks and automatic top sash locks.

16. The following are the window types accepted by the UMBS Committee
 - a. For residential applications:
 - (1) Single hung windows
 - (2) Double hung windows
 - (3) Other types required UM approval.
 - b. For institutional applications and high rise buildings:
 - (1) Fixed windows except at areas requiring escape windows in compliance with NFPA 101 requirements.

Product Standards

1. Manufacturers: Aluminum window manufacturer shall be listed in the current AAMA Certified Products Directory and bear AAMA quality certified seal.
2. Aluminum Window to comply with AAMA/WDMA/CSA 101/I.S.2/A440, Commercial Grade or Architectural Class and Florida Building Code Product Approval.
3. Approved Manufacturers
 - a. Kawneer North America; an Alcoa Company.
 - b. YKK AP America Inc.
 - c. CGI (at residential applications)
4. Finish
 - a. Provide uniform aluminum finish and color throughout the project. Specify 2-coat fluoropolymer finish complying with AAMA 2605 and containing not less than 70 percent PVDF resin by weight in color coat.
 - b. Color: White or Green to match UM samples. Provide uniform finish and color throughout.
 - c. Confirm that window manufacturer/finish manufacturer can provide a 20 year finish warranty.
 - d. In some existing buildings, finish may need to match an anodized finish; consult with the UMBS Committee before specifying finish.

Performance Standards

1. Submittal Requirements from Contractor:
 - a. Product Approval data from Florida Building Code or Miami-Dade County NOA Large Missile Impact Tested.
 - b. Samples of the following:
 - (1) 12 inch long aluminum sample of aluminum with specified finish.
 - (2) Sealant, including color to match aluminum.
 - (3) Glazing sample, 6x6 inch if factory glazed.
 - (4) Glazing gaskets.
 - (5) Weather stripping.
 - (6) Operable hardware.
 - c. Shop drawings showing materials, sizes, thickness, locations, construction details, frame reinforcing, glazing details, operable hardware accessories and erection details. Wind load and deflection calculations, signed and sealed by a Professional Structural Engineer registered in the State of Florida.

- d. Installer Qualifications.
 - e. Copy of warranties.
 - f. LEED submittals.
 - g. Mock-up samples.
2. Installer: Installation shall be by window manufacturer or window manufacturer's authorized installer.
 3. Warranty:
 - a. Request from the manufacturer and installer a 5 year written warranty against defective design, materials and workmanship including glass and seal failure on insulating glass units.
 - b. Request 20 year warranty on aluminum finish.
 4. Field Testing
 - a. Request field inspection by manufacturer of windows.
 - b. Request testing by a qualified independent testing and inspecting agency to perform field tests and inspections.
 - c. Test Method: AAMA 502-02 Method B for fixed and operable windows. Verify that this testing method can be performed at a reasonable cost; discuss cost with UM Staff before including requirement in specifications. If cost of AAMA 502-02 testing is prohibited, request Water Spray Test according to AAMA 501.2, modified as recommended by window manufacturer for window testing.

08 71 00 Door Hardware

Design Standards

1. Related Documents
 - a. Drawings and General Provisions of the contract, including general and supplemental conditions and Division 1 Specifications, apply to the work of this section.
 - b. Refer to University of Miami Access Control Policy and Procedures document.
2. Description of Work
 - a. Definition: "Finish Hardware" includes items known commercially as finish hardware which are required for swing, sliding and folding doors, except special types of unique and non-matching hardware specified in the same section as the door and frame or the security hardware and electronic security equipment.
 - b. Where interior doors to areas of public use are required to have a locking device, they shall be provided with stand-alone 'Schlage' access control locks compatible with the university systems (offices, conference rooms, or supply closets for example).
 - c. Exterior access doors at all academic buildings and residence halls shall have CBORD electronic access control systems (card swipe). CBORD shall be integrated with the central university system via network connection, with the ability of instant remote lock down activated from the UMPD communication center.

- 1) CBORD swipe access shall be provided at all interior and exterior elevators.
 - 2) Provide weather protection for the CBORD swipe units where they are exposed to rain.
 - d. The extent of the finish hardware is shown on the drawings and indicated in the enclosed schedules.
 - e. The types of finish hardware are listed; but not limited to the following:
 - 1) Hinges, pivots
 - 2) Cylinders, Keying, Keys
 - 3) Locks, Latches
 - 4) Surface and Flush bolts
 - 5) Fire Exit Devices
 - 6) Push and Pull Units
 - 7) Closers, Concealed, Overhead and Floor types
 - 8) Sliding and Bi-folding Door Hardware
 - 9) Overhead Door Holders, Floor and Wall Stops
 - 10) Protective Plates
 - 11) Weather stripping, Sound Seals, Light Seals
 - 12) Astragals
 - 13) Thresholds
 - 14) Electronic Security Equipment
 - f. The following items are listed in other sections:
 - 1) Overhead door operating equipment.
 - 2) Hardware for fire shutters
3. Quality Assurance:
 - a. Obtain each type of hardware (hinges, locks & latches, closers, overhead holders) from a single manufacturer, although several may be indicated as offering products complying with the requirements.
 - b. Supplier shall be a recognized architectural finish hardware contractor with warehousing facilities, who has been furnishing finish hardware in the projects vicinity for a period of not less than two years and who is, or who employs an experienced Architectural Hardware Consultant, who is available at reasonable times during the course of the work for consultation about the project's hardware requirements, to the architect, owner and general contractor.
 - c. Fire Rated Openings: Provide hardware for fire rated openings in compliance with NFPA 80 and local code requirements. Provide only hardware that has been tested and is listed by UNDERWRITER'S LABORATORY for the types and sizes of doors required and complies with the requirements of the door and frame labels. Where the emergency exit devices are required on fire rated doors, provide UL label on exit device indicating "FIRE EXIT HARDWARE". Provide door seals for smoke/draft-control doors and door assemblies in corridors and smoke barriers in compliance with FBC 710.5.2 and FBC 715.3.3.
4. Submittals
 - a. Product Data: Submit manufacturer's technical product data for each item of hardware in accordance with the Division-1 Section "Submittals". Include whatever information may be necessary to show compliance with the requirements, and include instructions for the installation and for the maintenance of the operating parts and finishes.

- b. Hardware Schedule Submit a final hardware schedule in the manner indicated below. Co-ordinate hardware with the doors, frames and related work to ensure proper size, thickness, hand, function and finish of hardware. Based on finish hardware indicated, organize the hardware schedule into sets indicating complete designations of every item of hardware required for each door or opening. Include the following information:
 - 1) Type, Style, Function, Size and Finish of the item of hardware.
 - 2) Name and Manufacturer of each item.
 - 3) Fastenings and other pertinent information.
 - 4) Location of hardware set, cross-referenced to the door number on the drawings and the hardware group in the specifications.
 - 5) Explanations of all abbreviations symbol and codes on the schedule.
 - 6) Door and Frame sizes and materials.
 - 7) Mounting information: Location on door, degree of opening and co-ordination with other items.
 - 8) Keying
 - 9) Wiring Diagrams for all openings using electrically operated hardware.
 - 10) MDPA/NOA, ITS, FBC approval and pressure ratings.
 - 11) LEED's V.30 Credits and information, End of Useful Life Recycle Program
 - c. Submit hardware schedule at the earliest possible date, as hardware schedule acceptance must precede fabrication of other work (i.e.: hollow metal frames), which are critical in the project construction schedule.
 - d. Wiring Diagram: Openings using electrically operated hardware will require a detailed, color coded, wiring diagram showing all components used in the opening. The hardware supplier will provide this diagram at the time of the hardware submittals. All diagrams and installations will use the University Standard Color coding at each opening for all equipment. Factory installation instructions from the various elements will not be accepted as meeting this requirement.

Diagram will include an elevation showing the location of various elements and power sources, a written description of the function of the opening and a custom diagram showing all runs and terminations for all the equipment used.
 - e. Submit templates for each fabricator of doors, frames and other related work to be factory prepared for the installation of hardware. Upon request, check shop drawings of other such work to confirm that adequate provisions are made for the proper location and installation of hardware.
 - f. Product Test Reports: Based on evaluation of comprehensive tests performed by manufacturer and witnessed by a qualified testing agency, indicating current products comply with requirements.
5. Product Handling:
- a. Tag each item or package separately with the identification related to the final hardware schedule; include basic installation instructions with each item or package.
 - b. Provide a secure lock-up for the hardware delivered to the jobsite but not installed. Control handling and installation of hardware items that are not immediately replaceable, so that completion of the work will not be delayed by hardware losses, both before and after installation.

- c. Deliver individually packaged hardware items at the proper time and locations (jobsite or shop) for installation.
- d. Inventory hardware jointly with the representative of the general contractor and the hardware supplier until each is satisfied that count is correct.

Product Standards

1. Standard Hardware
 - a. Requirements for the design, grade, function, finish, size and other distinctive qualities of each type of hardware are indicated in the hardware groups at the end of this section. The catalog numbers used in the hardware groups attached are from the University Standard. All material supplied shall match the University's existing materials and comply with the University's standardized replacement parts programs.
 - b. Any substitution request must be submitted to the architect with the catalog information, supporting data and samples, at least fourteen (14) working days prior to the bid date. Architect will review substitutions with the University. Approvals will be given in writing or by addendum only.
 - c. Supporting data must include BHMA Listing and Performance testing data, certified by an independent third party, showing required life cycle and other performance tests successfully completed. All submittals for substitution must show superior life cycle and vandal resistance to existing materials to be considered. Any product that does not fit the existing templates of current University materials and existing openings will not be considered for substitution.
2. Finishes
 - a. General: Match finish of every hardware unit at each door opening except as noted or as otherwise indicated in the attached hardware groups. In general, match all items to the manufacturer's standard finish for the latch or lockset (or push and pull units) for the color and texture. Door hardware shall be Brushed Stainless Steel or Brushed Chrome as noted in the schedule attached. Contractors will co-ordinate finish of hardware to be applied to aluminum doors with the storefront contractor.
 - b. At locations where tactile warnings are needed to meet the requirements of ADA, ANSI 117 or state and local codes; knobs, levers or crossbars will be "knurled" at the factory before finishing is applied to the base metal. Liquid abrasive or other field applied substances are NOT acceptable.
3. Hinges
 - a. All hinges will be manufactured to the standard template (ANSI 156.1) and supplied with Phillips flat head machine or wood screws as appropriate. Finish screw head to match exposed surface of hinges.
 - b. Except as otherwise indicated; provide hinge pins as follows;
 - 1) Steel Hinges: Steel hinge pins.
 - 2) Non-ferrous hinges: Stainless Steel hinge pins.
 - 3) Exterior and locking out swinging doors: Non-removable pins.
 - 4) Interior doors: Non-rising pins.
 - 5) Tips: Flush button and plugs, finished to match the leaf except where HT (hospital tip) is indicated.

- c. Number of Hinges: Provide the number of hinges indicated but not less than 3 hinges for each door leaf up to 90" in height and one additional hinge for each 30" of height. One Center Pivot will be supplied on all door leaves. Door leaves up to 86" in height. Additional Center pivot will be provided for each 30" of height. Doors that are oversized will be supplied with additional hinges or pivots as indicated in the schedule attached.
- d. Hinges will be a minimum of 4-1/2" in height and .134 thick. Width of hinge shall be sufficient to provide clearance for trim, applied door panels, frame moldings and door thickness.
- e. Life of Building Warranty for all hinges. Full replacement will be made for failure of mechanical operation or finish.

Performance Standards

1. Installation
 - a. Factory representatives of the lock, exit device and closer manufacturers will each provide one hour of installation training on the jobsite to the installation crew for this project.
 - b. Representatives will return to the jobsite after 20% of the hardware has been installed to check for problems and answer questions from the installation crew. Representative will inform the Architect, General Contractor and Owner, in writing, of any serious problems encountered during this inspection.
 - c. Mount hardware units at the height indicated in the "Recommended Locations for Builder's Hardware for Standard Steel Doors and Frames" by the Door and Hardware Institute; except as specifically indicated or required to comply with the governing regulations or as otherwise directed by the architect.
 - d. Install each hardware item in compliance with the manufacturer's recommendations and instructions. Whenever cutting or fitting is required to install hardware on or into surfaces which are later to be painted, or finished another way; co-ordinate removal, storage and the re-installation of hardware with the finishing work specified in Div. 9 sections. Do not install surface mounted hardware until finishes have been completed on the substrate.
 - e. Drill and counter sink units that are not factory prepared for anchorage fasteners. Space anchors and fasteners in accordance with industry standards.
 - f. Set thresholds for exterior openings in full bed of butyl rubber or polyisobutylene mastic sealant.
 - g. Adjust and clean each operating item of hardware and each door to ensure the proper operation or function of each unit. Replace units that cannot be adjusted to operate freely and smoothly as intended for the application made.
 - h. Provide owner's maintenance department with instructions for repair and maintenance of all door hardware used in the building. Training is to take place on the owner's site (project or maintenance department offices). Supplier will provide all tools, parts, samples and mock-ups for a complete education on all components of the door hardware.
 - i. Door hardware supplier will provide all documents, wiring diagrams and product information required for coordination with the security equipment, fire alarm and other trades involved in the installation of door operating systems. Door hardware supplier will have available, during normal business hours, an experienced

- hardware consultant to attend coordination meetings and provide input to assure a smoothly operating door system.
- j. Provide factory trained technicians to install and test card reader system. Start-up and complete system test is part of installation.
 - k. Provide owner's personnel with one day's of training by factory trained personnel on the operation and basic trouble shooting of the card access system. Training to take place at the building location, on or within 5 days, of the turnover to the Owner.
2. Continued Service and Warranty
- a. Representatives of the lock, exit device and closer manufacturers will inspect the hardware and installation in the seven days prior to the turnover of the building. Each opening will be examined for problems with materials and installation. A written report of their findings will be included with the warranty documents submitted to the owner at the turnover/occupancy of the building.
 - b. Approximately six months after the acceptance of the building, the installers, and representatives of the lock, exit device, closer and Card Reader manufacturers will return to the project. At that time they will re-adjust every item of hardware to restore proper function of doors and hardware. They will consult with the owner's personnel in recommended changes to the maintenance procedures and will replace items that have failed under the warranty period. A written report will be submitted to the architect describing current or predictable problems (of a substantial nature) in the performance of the hardware.
3. Hardware: Division 08 "OPENINGS" Appendix "A" Specification & Supplemental (Attachments) and Appendix "B" Door Hardware Card Access Diagrams (Attachments).
- a) Design Professional shall refer to the attached Division 08 Openings Appendix "A" and Appendix "B" Door Hardware Card Access Diagrams (Attachments) attached at the end of this division for reference and coordination as the "*Basis of Design*" for all standards and hardware used by UM Lock Shop. All hardware specified by the Design Professional on UMBS projects shall be reviewed and approved by UM Lock Shop prior to order, fabrication and delivery.

08 80 00 Glazing

Design Standards

1. General
This section provides guidelines for the selection of glazing for exterior and interior applications.
2. For exterior glazing specify glazing in framed systems that have Florida Building Code Product Approval or Miami Dade NOA Large Missile Impact testing. Select laminated glass or insulated laminated glass as required by energy considerations.
 - a. Laminated glass is to comply with ASTM C 1172, and with testing requirements described in 16 CFR 1201 for Category II materials.

- 1) Construction: Laminated glass shall have a polyvinyl butyral interlayer which complies with the manufacturer's written recommendations.
 - 2) Provide thickness not less than indicated and as needed to comply with manufacturer's requirements.
 - 3) Interlayer color shall be as selected by the architect/designer.
 - b. Insulated laminated glass units are to consist of sealed lites of glass separated by a dehydrated interspace complying with ASTM E 2190,
 - 1) Provide a dual seal, with the manufacturer's standard primary and secondary.
 - 2) Provide the manufacturer's standard spacer material and construction.
 - 3) The desiccant shall be molecular sieve or silica gel, or both.
3. Energy consideration for Exterior Glass: Exterior glass is to be Low E-coated, clear glass. The color and tint of the exterior glazing shall be selected to reduce energy consumption and as to meet solar heat gain coefficient / shading coefficient and U-factor recommended in the engineering analysis provided by the mechanical engineer:
 - a. Overall unit thickness: 1 inch (25 mm) recommended.
 - b. Outdoor lite: Heat strengthened float glass
 - c. Interspace content: Air
 - d. Indoor lite: Heat-strengthened float glass
 - e. Low-E Coating: Pyrolytic on third surface
 - f. Visible light transmittance: 0.62 percent minimum (recommended)
 - g. Winter Nighttime U-Factor: 0.29 maximum (recommended)
 - h. Summer Daytime U-Factor: 0.26 maximum (recommended)
 - i. Solar Heat Gain coefficient: 0.29 maximum (recommended)
4. Coordination of Drawings: Include on drawings a "Glass Legend" coordinated with opening elevations. Drawings to include dimensions of each framing system and glass opening. Do not attempt to indicate actual glass sizes or glass thickness.
 - a. Show direction of coated side of one-way glass. Coordinate with lighting design.
 - b. Coordinate Glass Legend with glazing specifications.
5. The use of film/coating in exposed glass is not permitted.
6. Glass colors and/or tint shall be selected from the UMBS Committee approved color palette.
7. Indicate the minimum glass thickness in the specifications. Request that Contractor assume design responsibility by delegating glass design, including thickness, to a qualified professional engineer using wind pressures indicated on drawings and as required by Florida Building Code.
8. Select the appropriate type of glass for the application. In general, use tempered glass for standard interior glazing; use laminated glass for exterior application, for security glazing and where acoustics are a concern. Specify edge condition on exposed glass.

9. Fire Rated Glazing: Select fire rated glazing that provides required fire protection rating and that meets safety glazing requirement. The use of wired glass is not allowed.
10. Setting Materials:
 - a. Setting materials required need to be coordinated with glazing manufacturer and framing manufacturer.
 - b. Laminated glass requires sealing of edges, especially on butt glazed installation to prevent migration of sealant into lamination. Request from manufacturer his recommendation and specified recommended product.
 - c. For Butt Glazed Interior Partitions, specify top and bottom channels. Finish and mounting to be determined, subject to approval by the UMBS Committee.
11. Add statement in specs requiring that all components of the glazing system be compatible.

Product Standards

1. Approved Manufacturers/Fabricators for Exterior Glazing:
Subject to compliance with these guidelines, applicable code requirements and Code Product approval:
 - a. Viracon.
 - b. PPG
 - c. Oldcastle BuildingEnvelope, Inc.

Performance Standards

1. Request the following submittals from the contractor for review and approval:
 - a. Product Data: Material specifications, maintenance recommendations and printed installation recommendations. Manufacturer's recommendations for setting blocks, spacers, method of securing glass to framing and edge clearances.
 - b. Manufacturer's Certificates:
 - (1) Certification that all glazing (exterior and interior) complies with testing requirements in 16 CFR 1201 for Category II material. Glazing must carry safety glazing label.
 - (2) Certification that fire rated glazing is listed and labeled by a testing agency acceptable to authorities having jurisdiction, for fire-protection ratings indicated, based on testing according to NFPA 252 for door assemblies and NFPA 257 for window assemblies and complies with testing requirements in 16 CFR 1201 for Category II materials.
 - c. Glazing samples: 6 inch square, of each type and color of glass required and 12 inch long samples of glazing accessories.
 - d. Color Charts: for glazing gaskets and glazing sealants for color selection by Architect-Engineer.
2. Quality Assurance:
 - a. Request that glass be permanently mark with certification label showing manufacturer's name, type of glass, thickness and safety glazing standard which glass complies with. Label shall indicate manufacturer's name, type of glass, thickness, and safety glazing standard with which glass complies.

- b. Warranty Requirements:
 - (1) Specify a 10-year manufacturer's warranty for coated-glass products.
 - (2) Specify a 5-year manufacturer's warranty for laminated glass.
 - (3) Specify a 10-year manufacturer's warranty for insulating glass products.
 - (4) Make sure specified glazing manufacturers offer warranties specified above.
 - (5) Ask the manufacturer's representative for a copy of the applicable warranty for each product.

08 83 00 Mirrors

Design Standards

1. This section provides guidelines for the materials selection of unframed mirrors.
2. Use film-backed glass mirrors qualifying as safety glazing.
3. Use top and bottom channels to hold mirrors in place.

Product Standards

1. Glass mirror standard: ASTM C1503/C1036, Quality Q1.
2. Require application of film backing as required complying with safety glazing product per testing requirements in 16 CFR 1201 for Category II materials.
3. Mirror glazing thickness: $\frac{1}{4}$ inch.
4. Specify edge treatment.
5. Require that edge sealer be applied to exposed edges of glass.
6. Require mechanical supports fabricated from clear anodized aluminum or stainless steel satin finish similar to J angles.

Performance Standards

1. Request the following submittals from the contractor for review and approval:
 - a. Product Data: Material specifications, edge sealer, mechanical supports and fasteners, maintenance recommendations and printed installation recommendations.
 - b. Shop Drawings: to include mirror elevations, edge details, mirror hardware, and attachments to other work.
 - c. Samples of the following
 - (1) Mirrors: showing edge treatment on two adjoining edges.
 - (2) Mirror mechanical supports/trim.
 - d. Maintenance Data.
 - e. Installer qualifications.

2. Warranty: Five years manufacturer's warranty from date of substantial completion against defects including black spots, clouding of the silver film, discoloration.

08 91 19 Wall Louvers

Design Standards

1. This section provides guidelines for the materials selection and design of exterior aluminum wall louvers.
2. Show on drawings louver sizes and profiles.
3. Generally, indicate horizontal drainable blade louvers.
4. Meet with mechanical and electrical engineers to determine louver performance rating requirement including but not limited to: Free area; point of beginning water penetration, air performance.
5. Specify Wind-Driven-Rain-Resistant Louver that provides required/specified wind-driven rain performance, as determined by testing according to AMCA 500-L.
6. Wall Louvers and attachment/support system shall be designed to withstand wind loads per Florida Building Code High Velocity Hurricane Zone requirements.
7. Louvers on project need to be obtained from single source from a single manufacturer.

Product Standards

1. Select Louvers from manufacturers that have Florida Building Code Product Approval or Miami Dade County Notice of Acceptance with large missile impact testing.
2. Require compliance with recommendations in SMACNA's "Architectural Sheet Metal Manual" for fabrication, construction details, and installation procedures should be required
3. Require that louvers carry AMCA Certified Ratings Seal.
4. Require that fasteners be fabricated from Type 316 stainless steel.
5. Require aluminum or stainless steel bird screens with removable frame.
6. Louver finish: Factory applied, 2-coat fluoropolymer finish complying with AAMA 2605 and containing not less than 70 percent PVDF resin by weight in color coat.
7. Color: As approved by the UMBS Committee.
8. Confirm if louver manufacturer/finish manufacturer can provide a 20 year finish warranty.

Performance Standards

1. Request the following submittals from the contractor for review and approval:
 - a. Product Data: Material specifications, fasteners, maintenance recommendations and printed installation recommendations.
 - b. Shop Drawings: to include plans, elevations, sections, details, and attachments to other work; frame profiles and blade profiles.
 - c. Delegated Design, including comprehensive engineering analysis by a qualified professional engineer, using structural performance requirements and design criteria indicated.
 - d. Samples of finishes and fastening devices.

3. Warranty: Require 20 year finish warranty, if available from manufacturer.

UMSECTION 087100 – DOOR HARDWARE

PART 1 - GENERAL

1.1 RELATED DOCUMENTS

- A. Drawings and general provisions of the Contract, including General and Supplementary Conditions and Division 01 Specification Sections, apply to this Section.
- B. University of Miami Access Control Policy and Procedures

1.2 SUMMARY

- A. Section includes:
 - 1. Mechanical and electrified door hardware for:
 - a. Swinging doors.
 - b. Sliding doors.
 - c. Gates.
 - 2. Electronic access control system components, including:
 - a. Electronic access control locksets and exit device trim.
 - 1) Where openings are required to have an electronic access control device, they shall have CBORD electronic access control systems (card swipe). CBORD shall be integrated with the central university system via network connection, with the ability of instant remote lock down activated from the UMPD communication center. Refer to University of Miami Access Control Policy and Procedures document. Areas include, but not limited to:
 - a) Doors to areas of public use (offices, conference rooms, or supply closets for example).
 - b) Exterior access doors at all academic buildings and residence halls.
 - c) All interior and exterior elevators.
 - d) Provide weather protection for the CBORD swipe units where they are exposed to rain.

- B. Exclusions: Unless specifically listed in hardware sets, hardware is not specified in this section for:
1. Windows
 2. Cabinets (casework), including locks in cabinets
 3. Signage
 4. Toilet accessories
 5. Overhead doors
- C. Related Sections:
1. Division 01 Section “Alternates” for alternates affecting this section.
 2. Section 05 75 10 (05075) - Distressed Metal Process.
 3. Section 06 20 00 (06200) - Finish Carpentry.
 4. Section 06 41 00 (06410) Architectural Wood Casework.
 5. Division 07 Section “Joint Sealants” for sealant requirements applicable to threshold installation specified in this section.
 6. Section 08 11 13 - Hollow Metal Doors and Frames.
 7. Section 08 14 16 - Flush Wood Doors.
 8. Section 08 14 33 - Stile and Rail Wood Doors.
 9. Section 08 16 13 (08225) - Fiberglass Doors and Frames.
 10. Section 08 36 13 - Sectional Doors.
 11. Section 08 43 13 - Aluminum-Framed Storefronts.
 12. Section 08 42 29 - Automatic Entrances.
 13. Division 09 sections for touchup finishing or refinishing of existing openings modified by this section.
 14. Division 13 - Special Construction.
 15. Division 26 sections for connections to electrical power system and for low-voltage wiring.
 16. Division 28 sections for coordination with other components of electronic access control system.

1.3 REFERENCES

A. Fire/Life Safety

1. NFPA - National Fire Protection Association
 - a. NFPA 70 – National Electric Code
 - b. NFPA 80 - Standard for Fire Doors and Fire Windows
 - c. NFPA 101 - Life Safety Code
 - d. NFPA 105 - Smoke and Draft Control Door Assemblies
2. State Fire Safety Code.

B. UL - Underwriters Laboratories

1. UL 10B - Fire Test of Door Assemblies
2. UL 10C - Positive Pressure Test of Fire Door Assemblies
3. UL 1784 - Air Leakage Tests of Door Assemblies
4. UL 305 - Panic Hardware
5. UL 294 – Access Control System Units

C. Accessibility

1. ADA - Americans with Disabilities Act.
2. ANSI A117.1 - Accessible and Usable Buildings and Facilities.

D. DHI - Door and Hardware Institute

1. Sequence and Format for the Hardware Schedule
2. Recommended Locations for Builders Hardware
3. Key Systems and Nomenclature

E. ANSI - American National Standards Institute

1. ANSI/BHMA A156.1 - A156.29, and ANSI A156.31 - Standards for Hardware and Specialties

F. FBC – Florida Building Code

1. 2014 Florida Building Code
2. Rule Chapter: 61G20-3 – Product Approval

1.4 SUBMITTALS

A. General:

1. Submit in accordance with Conditions of Contract and Division 01 requirements.
2. Highlight, encircle, or otherwise specifically identify on submittals deviations from Contract Documents, issues of incompatibility or other issues which may detrimentally affect the Work.
3. Before ordering any materials, prepare and submit shop drawings of all hardware materials on complete hardware schedule to Project Consultant for review.
4. At the completion of review, make corrections as directed and resubmit the corrected schedule for final approval and one (1) final copy hand delivered to UM Access Control office.
5. Approval of schedule will not relieve Contractor of the responsibility for furnishing all necessary hardware, including the responsibility for furnishing correct quantities.

2017 Edition

6. After hardware schedule has been approved, furnish templates required by manufacturing contractors for making proper provisions in their work for accurate fitting, finishing hardware setting.
7. Furnish templates in ample time to facilitate progress of work.
8. Door numbers and hardware groups are not to be changed.
9. Prior to forwarding submittal, comply with procedures for verifying existing door and frame compatibility for new hardware, as specified in PART 3, “EXAMINATION” article, herein.

B. Action Submittals:

1. Product Data: Product data including manufacturers’ technical product data for each item of door hardware, installation instructions, maintenance of operating parts and finish, and other information necessary to show compliance with requirements.
2. Riser and Wiring Diagrams: After final approval of hardware schedule, submit details of electrified door hardware, indicating:
 - a. Riser Diagrams: For power, signal, and control wiring and including:
 - 1) Raceway requirements of electrified door hardware including the point where coordination responsibility becomes “by others”.
 - 2) Cabling requirements of electrified door hardware including the point where coordination and provide responsibility becomes “by others”.
 - b. Wiring Diagrams: For power, signal, and control wiring and including:
 - 1) Details of interface of electrified door hardware and building safety and security systems.
 - 2) Schematic diagram of required interface of systems with electrified door hardware.
 - 3) Point-to-point wiring for all electronic door hardware systems.
3. Samples for Verification: If requested by Architect, submit production sample or sample installations of each type of exposed hardware unit in finish indicated, and tagged with full description for coordination with schedule.
 - a. Samples will be returned to supplier in like-new condition. Units that are acceptable to Architect may, after final check of operations, be incorporated into Work, within limitations of key coordination requirements.
4. Door Hardware Schedule: Submit schedule with hardware sets in vertical format as illustrated by Sequence of Format for the Hardware Schedule as published by the Door and Hardware Institute. Indicate complete designations of each item required for each door or opening, include:
 - a. Door Index; include door number, heading number, and Architects hardware set number.

2017 Edition

- b. Opening Lock Function Spreadsheet: List locking device and function for each opening.
 - c. Type, style, function, size, and finish of each hardware item.
 - d. Name and manufacturer of each item.
 - e. Fastenings and other pertinent information.
 - f. Location of each hardware set cross-referenced to indications on Drawings.
 - g. Explanation of all abbreviations, symbols, and codes contained in schedule.
 - h. Mounting locations for hardware.
 - i. Door and frame sizes and materials.
 - j. Name and phone number for local manufacturer's representative for each product.
 - k. Operational Description of openings with any electrified hardware (locks, exits, electromagnetic locks, electric strikes, automatic operators, door position switches, magnetic holders or closer/holder units, and access control components). Operational description should include how door will operate on egress, ingress, and fire and smoke alarm connection.
 - 1) Submittal Sequence: Submit door hardware schedule concurrent with submissions of Product Data, Samples, and Shop Drawings. Coordinate submission of door hardware schedule with scheduling requirements of other work to facilitate fabrication of other work that is critical in Project construction schedule.
5. Templates: After final approval of hardware schedule, provide templates for doors, frames and other work specified to be factory prepared for door hardware installation.

C. Informational Submittals:

- 1. Qualification Data: For Supplier, Installer and Architectural Hardware Consultant.
- 2. Product Certificates for electrified door hardware, signed by manufacturer:
 - a. Certify that door hardware approved for use on types and sizes of labeled fire-rated doors complies with listed fire-rated door assemblies.
- 3. Certificates of Compliance:
 - a. Certificates of compliance for fire-rated hardware and installation instructions if requested by Architect or Authority Having Jurisdiction.
 - b. Installer Training Meeting Certification: Letter of compliance, signed by Contractor, attesting to completion of installer training meeting specified in “QUALITY ASSURANCE” article, herein.
 - c. Electrified Hardware Coordination Conference Certification: Letter of compliance, signed by Contractor, attesting to completion of electrified hardware coordination conference, specified in “QUALITY ASSURANCE” article, herein.

2017 Edition

4. Product Test Reports:
 - a. For compliance with accessibility requirements, based on evaluation of comprehensive tests performed by manufacturer and witnessed by qualified testing agency, for door hardware on doors located in accessible routes.
 - b. For compliance with Florida Building Code product approval requirements for hardware systems located on exterior doors in wind borne debris regions as designated in Florida Building Code.
5. Warranty: Provide statements of Warranty for each hardware type provided.

D. Closeout Submittals:

1. Operations and Maintenance Data : Provide in accordance with Division 01 and include:
 - a. Complete information on care, maintenance, and adjustment; data on repair and replacement parts, and information on preservation of finishes.
 - b. Catalog pages for each product.
 - c. Name, address, and phone number of local representative for each manufacturer.
 - d. Parts list for each product.
 - e. Final approved hardware schedule, edited to reflect conditions as-installed.
 - f. Copies of floor plans with keyed locations and cylinder types
 - g. As-installed wiring diagrams for each opening connected to power, both low voltage and 110 volts.
 - h. Copy of statement of warranties including appropriate reference numbers for manufacturers to identify product to be warranted. This could include, but is not limited to serial numbers, order numbers, or PO numbers.

1.5 QUALITY ASSURANCE

- A. Product Substitutions: Comply with product requirements stated in Division 01 and as specified herein.
 1. Where specific manufacturer’s product is named and accompanied by “No Substitute,” including make or model number or other designation, provide product specified. (Note: Certain products have been selected for their unique characteristics and particular project suitability.)
 - a. Where no additional products or manufacturers are listed in product category, requirements for “No Substitute” govern product selection.
 2. Where products indicate “acceptable substitute” or “acceptable manufacturer”, provide product from specified manufacturers, subject to compliance with specified requirements and “Single Source Responsibility” requirements stated herein.

2017 Edition

- B. Supplier Qualifications and Responsibilities: Recognized architectural hardware supplier with record of successful in-service performance for supplying door hardware similar in quantity, type, and quality to that indicated for this Project and that provides certified Architectural Hardware Consultant (AHC) available to Owner, Architect, and Contractor, at reasonable times during the Work for consultation.
1. Warehousing Facilities: In Project's vicinity.
 2. Scheduling Responsibility: Preparation of door hardware.
 3. Engineering Responsibility: Preparation of data for electrified door hardware, including Shop Drawings, based on testing and engineering analysis of manufacturer's standard units in assemblies similar to those indicated for this Project.
 4. Coordination Responsibility: Coordinate installation of electronic security hardware with Architect and electrical engineers and provide installation and technical data to Architect and other related subcontractors.
 - a. Upon completion of electronic security hardware installation, inspect and verify that all components are working properly including, if required, providing temporary power to test proper operation.
- C. Installer Qualifications: Qualified tradesmen, skilled in application of commercial grade hardware with record of successful in-service performance for installing door hardware similar in quantity, type, and quality to that indicated for this Project.
- D. Architectural Hardware Consultant Qualifications: Person who is experienced in providing consulting services for door hardware installations that are comparable in material, design, and extent to that indicated for this Project and meets these requirements:
1. For door hardware, DHI-certified, Architectural Hardware Consultant (AHC).
 2. Can provide installation and technical data to Architect and other related subcontractors.
 3. Can inspect and verify components are in working order upon completion of installation.
 4. Capable of producing wiring diagrams.
 5. Capable of coordinating installation of electrified hardware with Architect and electrical engineers.
- E. Single Source Responsibility: Obtain each type of door hardware from single manufacturer.
1. Provide electrified door hardware from same manufacturer as mechanical door hardware, unless otherwise indicated.
 2. Manufacturers that perform electrical modifications and that are listed by testing and inspecting agency acceptable to authorities having jurisdiction are acceptable.

2017 Edition

- F. Fire-Rated Door Openings: Provide door hardware for fire-rated openings that complies with NFPA 80 and requirements of authorities having jurisdiction. Provide only items of door hardware that are listed and are identical to products tested by Underwriters Laboratories, Intertek Testing Services, or other testing and inspecting organizations acceptable to authorities having jurisdiction for use on types and sizes of doors indicated, based on testing at positive pressure and according to NFPA 252 or UL 10C and in compliance with requirements of fire-rated door and door frame labels.
- G. Smoke- and Draft-Control Door Assemblies: Where smoke- and draft-control door assemblies are required, provide door hardware that meets requirements of assemblies tested according to UL 1784 and installed in compliance with NFPA 105.
1. Air Leakage Rate: Maximum air leakage of 0.3 cfm/sq. ft. (3 cu. m per minute/sq. m) at tested pressure differential of 0.3-inch wg (75 Pa) of water.
- H. Electrified Door Hardware: Listed and labeled as defined in NFPA 70, Article 100, by testing agency acceptable to authorities having jurisdiction.
- I. Means of Egress Doors: Latches do not require more than 15 lbf (67 N) to release latch. Locks do not require use of key, tool, or special knowledge for operation.
- J. Accessibility Requirements: For door hardware on doors in an accessible route, comply with governing accessibility regulations cited in “REFERENCES” article, herein.
1. Provide operating devices that do not require tight grasping, pinching, or twisting of wrist and that operate with force of not more than 5 lbf (22.2 N).
 2. Maximum opening-force requirements:
 - a. Interior, Non-Fire-Rated Hinged Doors: 5 lbf (22.2 N) applied perpendicular to door.
 - b. Sliding or Folding Doors: 5 lbf (22.2 N) applied parallel to door at latch.
 - c. Fire Doors: Minimum opening force allowable by authorities having jurisdiction.
 3. Bevel raised thresholds with slope of not more than 1:2. Provide thresholds not more than 1/2 inch (13 mm) high.
 4. Adjust door closer sweep periods so that, from open position of 70 degrees, door will take at least 3 seconds to move to 3 inches (75 mm) from latch, measured to leading edge of door.
- K. Pre-installation Conference: Conduct conference at Project site.
1. Review and finalize construction schedule and verify availability of materials, Installer's personnel, equipment, and facilities needed to make progress and avoid delays.
 2. Inspect and discuss preparatory work performed by other trades.

3. Inspect and discuss electrical roughing-in for electrified door hardware.
4. Review sequence of operation for each type of electrified door hardware.
5. Review required testing, inspecting, and certifying procedures.

L. Coordination Conferences:

1. Installation Coordination Conference: Prior to hardware installation, schedule and hold meeting to review questions or concerns related to proper installation and adjustment of door hardware.
 - a. Attendees: Door hardware supplier, doors and frames supplier, door hardware installer, Contractor, Architect, Owner.
 - b. After meeting, provide letter of compliance to Architect, indicating when meeting was held and who was in attendance.
2. Electrified Hardware Coordination Conference: Prior to ordering electrified hardware, schedule and hold meeting to coordinate door hardware with security, electrical, doors and frames, and other related suppliers.
 - a. Attendees: electrified door hardware supplier, doors and frames supplier, electrified door hardware installer, electrical subcontractor, Owner, Architect, and Contractor.
 - b. After meeting, provide letter of compliance to Architect, indicating when coordination conference was held and who was in attendance.

1.6 DELIVERY, STORAGE, AND HANDLING

- A. Inventory door hardware on receipt and provide secure lock-up for hardware delivered to Project site.
- B. Send duplicate lists of hardware in each shipment to the contractor. Ensure original list accompanies shipment. Hardware Vendor: pay shipping and delivery charges.
- C. Tag each item or package separately with identification coordinated with final door hardware schedule, and include installation instructions, templates, and necessary fasteners with each item or package.
 1. Deliver each article of hardware in manufacturer’s original packaging.
- D. Project Conditions:
 1. Maintain manufacturer-recommended environmental conditions throughout storage and installation periods.
 2. Provide secure lock-up for door hardware delivered to Project, but not yet installed. Control handling and installation of hardware items so that completion of Work will not be delayed by hardware losses both before and after installation.

- E. Protection and Damage:
 - 1. Promptly replace products damaged during shipping.
 - 2. Handle hardware in manner to avoid damage, marring, or scratching. Correct, replace or repair products damaged during Work.
 - 3. Protect products against malfunction due to paint, solvent, cleanser, or any chemical agent.
- F. Deliver keys and permanent cores to Owner by registered mail or overnight package service.

1.7 COORDINATION

- A. Coordinate layout and installation of floor-recessed door hardware with floor construction. Cast anchoring inserts into concrete. Concrete, reinforcement, and formwork requirements are specified in Division 03.
- B. Installation Templates: Distribute for doors, frames, and other work specified to be factory prepared. Check Shop Drawings of other work to confirm that adequate provisions are made for locating and installing door hardware to comply with indicated requirements.
- C. Security: Coordinate installation of door hardware, construction keying, and access control with Owner.
- D. Electrical System Roughing-In: Coordinate layout and installation of electrified door hardware with connections to power supplies and building safety and security systems.
- E. Existing Openings: Where hardware components are scheduled for application to existing construction or where modifications to existing door hardware are required, field verify existing conditions and coordinate installation of door hardware to suit opening conditions and to provide proper door operation.
- F. Direct shipments not permitted, unless approved by Contractor.

1.8 WARRANTY

- A. Special Warranty: Manufacturer's standard form in which manufacturer agrees to repair or replace components of door hardware that fail in materials or workmanship within specified warranty period.
 - 1. All hardware and installation must provide warranty against defects and workmanship; refer to Division 1 for proper clarifications.
 - 2. Warranty Period: Years from date of Substantial Completion, for durations indicated.

- a. Closers:
 - 1) Surface Mechanical: 30 years.
 - 2) Concealed Mechanical: 15 years
 - 3) Electrified: 2 years.
- b. Automatic Operators: 2 years.
- c. Exit Devices:
 - 1) Mechanical: 3 years.
 - 2) Electrified: 1 year.
- d. Locksets:
 - 1) Mechanical: 3 years.
 - 2) Electrified: 1 year.

1.9 MAINTENANCE

A. Extra Materials:

- 1. Furnish extra materials that match products installed and that are packaged with protective covering for storage and identified with labels describing contents.
 - a. Materials shall be delivered to Owner.
 - b. Provide for each product exceeding a quantity of 10:
 - 1) Door Hardware: 5 percent of quantity required for the project, or a minimum of one.
 - 2) Cylinders: 5 percent of quantity required for the project, or a minimum of one.
 - 3) Electrical Parts: 5 percent of quantity required for the project, or a minimum of one.

B. Maintenance Tools:

- 1. Furnish complete set of special tools required for maintenance and adjustment of hardware, including changing of cylinders.

PART 2 - PRODUCTS

2.1 MANUFACTURERS

- A. The Owner requires use of certain products for their unique characteristics and particular project suitability to ensure continuity of existing and future performance and maintenance standards. After investigating available product offerings Awarding Authority has elected to prepare proprietary specifications. These products are specified with the notation: “No Substitute.”

BUILDING STANDARDS – APPENDIX “A” MASTER DOOR HARDWARE
 University of Miami SPECIFICATION 08 70 00

2017 Edition

1. Where “No Substitute” is noted, submittals and substitution requests for other products will not be considered.
- B. Approval of manufacturers other than those listed shall be in accordance with QUALITY ASSURANCE article, herein.
- C. Approval of products indicated as alternative is contingent upon those products providing all functions and features and meeting all requirements of standard manufacturer’s product.

Item	Standard Manufacturer	Alternative Subject to UMBS Committee Approval
Hinges	Ives (IVE)	Hager, Stanley
Electric Power Transfer	Von Duprin (VON)	No Substitute
Flush Bolt	Ives (IVE)	Rockwood
Surface Bolts	Ives (IVE)	Rockwood
Coordinators	Ives (IVE)	Rockwood
Cylindrical Locksets	Schlage (SCH)	No Substitute
Exit Devices & Mullions	Von Duprin (VON)	Equivalent subject to UMBS Committee approval.
Electronic Lockset – (All-in-one)	Schlage – Electronic (SCE)	No Substitute
Electric Strikes	Von Duprin (VON)	No Substitute
Power Supplies – Exit Devices	Von Duprin (VON)	No Substitute
Power Supplies	Schlage Electronics (SCE)	Altronix
Cylinders	Schlage (SCH)	No Substitute
Door Closers	LCN (LCN)	No Substitute
Closer/Holder Unit	LCN (LCN)	No Substitute
Electro-Hydraulic Automatic Operators	LCN (LCN)	No Substitute
Electro-Mechanical Automatic Operators	LCN (LCN)	No Substitute
Door Trim	Ives (IVE)	Rockwood
Protection Plates	Ives (IVE)	Rockwood
Overhead Stops	Glynn-Johnson (GLY)	Rixson
Stops & Holders	Ives (IVE)	Rockwood
Thresholds & Weatherstrip	Zero (ZER)	National Guard
Silencers	Ives (IVE)	No Substitute
Magnetic Holders	LCN (LCN)	Rixson
Biometric Readers	Morpho	No Substitute

2017 Edition

- D. Hand of Door: Drawings show direction of slide, swing, or hand of each door leaf. Furnish each item of hardware for proper installation and operation of door movement as shown.
- E. Where specified hardware is not adaptable to finished shape or size of members requiring hardware, furnish suitable types having same operation and quality as type specified, subject to UMBS Committee approval.

2.2 EXISTING MATERIALS

- A. Where existing door hardware is indicated to be removed and reinstalled:
 - 1. Carefully remove door hardware and components.
 - 2. Clean, protect and store existing door hardware in accordance with storage and handling requirements specified herein.
 - 3. Reinstall in accordance with installation requirements for new door hardware.

2.3 MATERIALS

- A. Fasteners
 - 1. Provide hardware manufactured to conform to published templates, generally prepared for machine screw installation.
 - 2. Furnish screws for installation with each hardware item. Finish exposed (exposed under any condition) screws to match hardware finish, or, if exposed in surfaces of other work, to match finish of this other work including prepared for paint surfaces to receive painted finish.
 - 3. Provide concealed fasteners for hardware units exposed when door is closed except when no standard units of type specified are available with concealed fasteners. Do not use thru-bolts for installation where bolt head or nut on opposite face is exposed in other work unless thru-bolts are required to fasten hardware securely. Review door specification and advise Architect if thru-bolts are required.
 - 4. Install hardware with fasteners provided by hardware manufacturer.
- B. Modification and Preparation of Existing Doors: Provide necessary fillers, Dutchmen, reinforcements, and fasteners, compatible with existing materials, as required for mounting new opening hardware and to cover existing door and frame preparations.
 - 1. Use materials which match materials of adjacent modified areas.
 - 2. When modifying existing fire-rated openings, provide materials permitted by NFPA 80 as required to maintain fire-rating.
- C. Provide screws, bolts, expansion shields, drop plates and other devices necessary for hardware installation.

1. Where fasteners are exposed to view: Finish to match adjacent door hardware material.

2.4 HINGES

A. Provide five-knuckle, ball bearing hinges.

1. Manufacturers and Products:
 - a. Scheduled Manufacturer and Product: Ives 5BB series.
 - b. Acceptable Manufacturers and Products: Hager BB series, Stanley FBB Series.

B. Requirements:

1. 1-3/4 inch (44 mm) thick doors, up to and including 36 inches (914 mm) wide and less than 150 lbs.
 - a. Exterior: Standard weight, bronze or stainless steel, 4-1/2 inches (114 mm) high
 - b. Interior: Standard weight, steel, 4-1/2 inches (114 mm) high
2. 1-3/4 inch (44 mm) thick doors over 36 inches (914 mm) wide and/or greater than 150 lbs.:
 - a. Exterior: Heavy weight, bronze/stainless steel, 5 inches (127 mm) high
 - b. Interior: Heavy weight, steel, 5 inches (127 mm) high
3. 2 inches or thicker doors:
 - a. Exterior: Heavy weight, bronze or stainless steel, 5 inches (127 mm) high
 - b. Interior: Heavy weight, steel, 5 inches (127 mm) high
4. Width of hinges: 4-1/2 inches (114 mm) at 1-3/4 inch (44 mm) thick doors, and 5 inches (127 mm) at 2 inches (51 mm) or thicker doors. Adjust hinge width as required for door, frame, and wall conditions to allow proper degree of opening.
5. Provide three hinges per door leaf for doors 90 inches (2286 mm) or less in height, and one additional hinge for each 30 inches (762 mm) of additional door height.
6. Where new hinges are specified for existing doors or existing frames, provide new hinges of identical size to hinge preparation present in existing door or existing frame.
7. Hinge Pins: Except as otherwise indicated, provide hinge pins as follows:
 - a. Steel Hinges: Steel pins
 - b. Non-Ferrous Hinges: Stainless steel pins
 - c. Out-Swinging Exterior Doors: Non-removable pins

2017 Edition

- d. Out-Swinging Interior Lockable Doors: Non-removable pins
- e. Interior Non-lockable Doors: Non-rising pins

- 8. Provide hinges with electrified options as scheduled in the hardware sets. Provide with sufficient number and wire gage to accommodate electric function of specified hardware. Locate electric hinge at second hinge from bottom or nearest to electrified locking component.
- 9. Provide mortar guard for each electrified hinge specified, unless specified in hollow metal frame specification.

2.5 ELECTRIC POWER TRANSFER

- A. Manufacturers:
 - a. Scheduled Manufacturer: Von Duprin
 - b. Acceptable Manufacturers: No Substitute

- B. Provide power transfer with electrified options as scheduled in the hardware sets. Provide with number and gage of wires sufficient to accommodate electric function of specified hardware.

- C. Doors and Frames with electronic locks must be factory prepared for Von Duprin EPT Power Transfer, Wire Raceway, and back boxes for electrical conduit connection.

- D. Locate electric power transfer per manufacturer's template and UL requirements, unless interference with operation of door or other hardware items.

2.6 FLUSH BOLTS

- A. Manufacturers:
 - 1. Scheduled Manufacturer: Ives
 - 2. Acceptable Manufacturers: Rockwood

- B. Requirements:
 - 1. Provide automatic, constant latching, and manual flush bolts with forged bronze or stainless steel face plates, extruded brass levers, and with wrought brass guides and strikes. Provide 12 inch (305 mm) steel or brass rods at doors up to 90 inches (2286 mm) in height. For doors over 90 inches (2286 mm) in height increase top rods by 6 inches (152 mm) for each additional 6 inches (152 mm) of door height. Provide dust-proof strikes at each bottom flush bolt.

2.7 SURFACE BOLTS

A. Manufacturers:

1. Scheduled Manufacturer: Ives
2. Acceptable Manufacturers: Rockwood

B. Requirements:

1. Surface bolts to have 1” throw for maximum security with concealed mounting that prevents vandalism. Units to be constructed of heavy duty steel and cUL listed up to three (3) hours when used on the inactive door of a pair up to 8’ in height.

2.8 COORDINATORS

A. Manufacturers:

1. Scheduled Manufacturer: Ives
2. Acceptable Manufacturers: Rockwood

B. Requirements:

1. Where pairs of doors are equipped with automatic flush bolts, an astragal, or other hardware that requires synchronized closing of the doors, provide bar-type coordinating device, surface applied to underside of stop at frame head.
2. Provide filler bar of correct length for unit to span entire width of opening, and appropriate brackets for parallel arm door closers and surface vertical rod exit device strikes. Factory-prep coordinators for vertical rod devices if required.

2.9 LOCKS AND LATCHSETS

A. Manufacturers and Products:

1. Scheduled Manufacturer and Product: Schlage ND Series
2. Acceptable Manufacturers and Products: No Substitute

B. Requirements:

1. Provide cylindrical locks conforming to ANSI A156.2 Series 4000, Grade 1. Cylinders: Refer to “KEYING” article, herein.
2. Provide cylindrical locks with classroom security function where indicated. Locks will have an inside indicator that provides clear direction for users to safely and quickly secure the room.

2017 Edition

3. Provide locksets able to withstand 1500 inch pounds of torque applied to locked outside lever without gaining access per ANSI A156.2 Abusive Locked Lever Torque Test and cycle tested to 3 million cycles per ANSI A156.2 Cycle Test.
4. Provide levers with vandal resistant technology for use at heavy traffic or abusive applications. Levers feature internal lock components that prevent damage caused by excessive force from persons kicking, hitting or standing on lever to gain access.
5. Provide solid steel rotational stops to control excessive rotation of lever.
6. Provide completely refunctionable lockset that allows lock function to be changed to over twenty other common functions by swapping easily accessible parts.
7. Provide locks with standard 2-3/4 inches (70 mm) backset, unless noted otherwise, with 1/2 inch latch throw. Provide proper latch throw for UL listing at pairs.
8. Provide locksets with separate anti-rotation thru-bolts, and no exposed screws.
9. Provide independently operating levers with two external return spring cassettes mounted under roses to prevent lever sag.
10. Provide standard ASA strikes unless extended lip strikes are necessary to protect trim.
11. Provide electrified options as scheduled in the hardware sets.
12. Lever Trim: Solid cast levers without plastic inserts, and wrought roses on both sides.
 - a. Lever Design: Schlage Athens.
 - b. Tactile Warning (Knurling): Where required by authority having jurisdiction. Provide on levers on exterior (secure side) of doors serving rooms considered to be hazardous.

2.10 EXIT DEVICES

- A. Manufacturer and Product: Von Duprin 98 series, or equivalent subject to **UMBS Committee** approval.
- B. Requirements:
 1. Provide exit devices tested to ANSI/BHMA A156.3 Grade 1 and UL listed for Panic Exit or Fire Exit Hardware. Cylinders: Refer to “KEYING” article, herein.
 2. Provide touchpad type exit devices, fabricated of brass, bronze, stainless steel, or aluminum, plated to standard architectural finishes to match balance of door hardware.
 3. Quiet Operation: Incorporate fluid damper or other device that eliminates noise of exit device operation.
 4. Touchpad: Extend minimum of one half of door width, but not the full length of exit device rail. Provide end-cap with two-point attachment to door. Match exit device finish, stainless steel for US26, US26D, US28, US32, and US32D finishes; and for all other finishes, provide compatible finish to exit device.

2017 Edition

- Provide compression springs in devices, latches, and outside trims or controls; tension springs prohibited.
5. Provide rim devices with a dual cylinder or inside thumb turn cylinder option with a visual security indicator that identifies the trims locked/unlocked status of the door from the inside of the room. Indicator in unlocked state presents a 1/2 inch x 1/2 inch white metal flag with black icon at top of device head. Indicator in locked state has no flag present. Provide rim devices without the dual cylinder or inside thumb turn cylinder option capable of being retrofitted with the visual security indicator.
 6. Provide exit devices with dead latching feature for security and for future addition of alarm kits and/or other electrical requirements.
 7. Provide an exit device with manufacturer’s approved strikes.
 8. Provide exit devices cut to door width and height. Locate exit devices at height recommended by exit device manufacturer, allowable by governing building codes, and approved by Architect.
 9. Mount mechanism case flush on face of doors, or provide spacers to fill gaps behind devices. Where glass trim or molding projects off face of door, provide glass bead kits.
 10. Provide cylinder dogging at non-fire-rated exit devices, unless specified less dogging.
 11. Removable Mullions: 2 inches (51 mm) x 3 inches (76 mm) steel tube. Where scheduled as keyed removable mullion that is removed by use of a keyed cylinder, which is self-locking when re-installed.
 12. Where lever handles are specified as outside trim for exit devices, provide heavy-duty lever trims with forged or cast escutcheon plates. Provide vandal-resistant levers that will travel to 90-degree down position when more than 35 pounds of torque are applied, and which can easily be re-set.
 - a. Lever Style: Match lever style of locksets.
 - b. Tactile Warning (Knurling): Where required by authority having jurisdiction. Provide on levers on exterior (secure side) of doors serving rooms considered to be hazardous.
 13. Provide UL labeled fire exit hardware for fire rated openings.
 14. Provide factory drilled weep holes for exit devices used in full exterior application, highly corrosive areas, and where noted in hardware sets.
 15. Provide electrified options as scheduled in the hardware sets.

2.11 ELECTRONIC ACCESS CONTROL LOCKSETS

A. Manufacturers and Products:

1. Scheduled Manufacturer and Product: Schlage AD series. No Substitute.
2. ALL ELECTRONIC ACCESS CONTROL LOCKSETS AND CARD READERS TO BE SUPPLIED AND INSTALLED BY SECURITY INTEGRATION DIVISION 28.

2017 Edition

- a. General Contractor shall subcontract a licensed (State of FL, Miami Dade Co.) Security integration contractor for all Division 28 requirements. Whom shall furnish; install a full integrated system. Including but not limited to wiring, card lock, termination & programming. For any questions regarding the integration related information & details contact UM.
- B. Requirements: Electronic locksets shall comply with the following requirements.
1. Cylindrical:
 - a. Type: Heavy-duty, bored cylindrical, non-handed, field-reversible.
 - b. Backset: 2-3/4-inch (70 mm) standard, with 2-3/8-inch (60 mm), 3-3/4-inch (95 mm) and 5-inch (127 mm) backset optional.
 - c. Latch bolt Throw: 1/2-inch (13 mm) with optional 3/4-inch (19 mm) throw available.
 - d. Chassis: Shall accommodate standard 161 cylindrical lock prep for 1-3/4-inch (44 mm) doors standard, or 1-3/8-inch (35 mm) to 2-3/4-inch (70 mm) thick doors in 1/8-inch (3 mm) increments.
 2. Exit Device Trim
 - a. Type: Exit device trim, non-handed, field-reversible.
 - b. Exit Device Configurations: Exit device lever trim to retract latch bolt for the following exit device applications:
 - 1) Rim
 - 2) Surface vertical rod
 - 3) Mortise
 - 4) Concealed vertical rod/cable
 3. Exit Device Compatibility: Provide exit device trim with universal mounting plate enabling operation as follows:
 - a. All Von Duprin 98 Series exit device configurations.
 4. Applicable Standards:
 - a. Listed, UL 294 - The Standard of Safety for Access Control System Units.
 - b. Compliant with ANSI Standard A156.25 and A156.2 Series 4000, Grade 1 strength and operational requirements.
 - c. Compliant with ANSI/BHMA A156.25 Grade 1 Operation and Security Requirement.
 - d. Certified to UL10C, FCC Part15, Florida Building Code Standards TAS 201 large missile impact, TAS 202 and TAS 203.
 - e. Compliant with ASTM E330 for door assemblies.
 - f. Compliant with ICC / ANSI A117.1, NFPA 101, NFPA 80, and Industry Canada IC.

2017 Edition

5. Lockset Functions: Provide locks with following functions, as scheduled, that are field configurable without taking the lock off the door:
 - a. Classroom / Storeroom 70.
 - b. Apartment 60.
 - c. Office 50.
 - d. Privacy 40.
6. Emergency Override: Provide mechanical key override for Schlage LFIC core size cylinder; cylinders: Refer to “KEYING” article, herein.
7. Levers:
 - a. Vandal Resistance: Exterior (secure side) lever designed with ability to rotate freely while door remains securely locked, preventing damage to internal lock components from vandalism by excessive force.
 - b. Lever trim to be non-handed, and to operate independently of non-locking levers for extended life cycles.
 - c. Style: Athens
 - d. Tactile Warning (Knurling): Where required by authority having jurisdiction. Provide on levers on exterior (secure side) of doors serving rooms considered to be hazardous.
8. Power Supply:
 - a. Wireless:
 - 1) Lockset powered by four AA batteries or a 12VDC or 24VDC power supply with an option for eight AA batteries.
 - 2) Lockset shall have ability to communicate battery status.
 - b. Wired:
 - 1) Lockset powered by a 12VDC or 24VDC power supply
9. Features: Locksets shall incorporate the following features.
 - a. Visual tri-colored LED indicators that indicate activation, additional PIN code credential required, operational systems status, system error conditions and low power conditions.
 - b. Visual bi-colored LED indicator on interior that is capable of indicating secured/unsecured status of device to occupants on interior.
 - c. Audible feedback that can be enabled or disabled.
 - d. Onboard processor with memory capacity of 5,000 users, 5,000 event audit history, up to 16 time zones and up to 32 calendar events for offline applications.
 - e. Tamper-Resistant Screws: Tamper torx screws on inside escutcheon for increased security.

10. Adaptability:
 - a. Networking Capabilities: Network adaptable without removing device from door. Lockset to have the ability to be upgraded in the field from a standalone battery powered configuration to a wireless networked configuration without being removed from the door.
 - b. Field changeable Reader Modules: Lockset to have the ability to change credential reader technologies without being removed from door.
11. Switches: Provide locksets with the following switches, standard:
 - a. Door Position Switch
 - b. Interior Cover Tamper Guard
 - c. Mechanical Key Override
 - d. Request to Exit
 - e. Request to Enter
 - f. Lock/Unlock Status (Clutch Position).
12. Credential Reader: Provide magnetic stripe or multi-technology credential reader modules with keypad as indicated in door hardware sets. Multi-tech contactless reader shall be NFC-Compatible and read access control data from both 125 kHz and 13.56 MHz contactless smart cards.
13. Operation:
 - a. Wireless Transmission:
 - 1) Modulation: 900 MHz spread spectrum, direct sequence, 10 channels.
 - 2) Encryption: AES-128 bit Key minimum.
 - b. Wired Transmission
 - 1) RS485
 - c. Provide electronic lock with the following interface capabilities:
 - 1) Wireless
 - a) Wiegand or Clock & Data via PIM400-TD2 (Panel Interface Module).
 - b) RS485 via PIM400-485.
 - 2) Wired
 - a) Wiegand or Clock & Data via PIB300 (Panel Interface Board).
 - b) Directly via RS485.
 - d. Lockset to have real-time bidirectional communication between access control system and lock.
 - e. Credential Verification Time: less than 1 second.
 - f. When Utilized with Partner Integrated Access Control Network Software With Remote Commanding Capability: Lockset shall have ability to be remotely locked down or unlocked within 10 seconds or less, without user interface at the device.

2017 Edition

- g. Upon Loss of Power to Lockset: Lockset shall have ability to manage access control offline in one of three methods below that can be configured in the field at lockset by handheld programming device and remotely by Partner integrated software:
 - 1) Fail locked (secured)
 - 2) Fail unlocked (unsecured)
 - 3) Fail As-Is
- h. Upon Loss of Communication Between Lockset and Network: Lockset shall have ability to manage access control offline in one of four methods below that can be configured in the field at lockset by handheld programming device and remotely by Partner integrated software:
 - 1) Fail locked (secured)
 - 2) Fail unlocked (unsecured)
 - 3) Fail As-Is
 - 4) Fail to Degraded/cache mode utilizing cache memory with following selectable options:
 - a) Grant access up to the last 1,000 unique previously accepted User IDs.
 - b) Grant access up to the last 1,000 unique previously accepted facility/site codes.
 - c) Remove from cache previously stored User IDs or facility/site codes that have not been presented to lock within the last 5 days.
- i. Lockset shall have ability to be configured at door by handheld programming device and remotely by Partner integrated software the length of time device is unlocked upon access grant.
- j. Lockset shall have the ability to communicate identifying information such as firmware versions, hardware versions, serial numbers, and manufacturing dates by handheld programming device and remotely by Partner integrated software.

2.12 ELECTRIC STRIKES

A. Manufacturers and Products:

- 1. Scheduled Manufacturer and Product: Von Duprin 6000 series
- 2. Acceptable Manufacturers and Products: No Substitute

B. Requirements:

- 1. Provide electric strikes designed for use with type of locks shown at each opening.
- 2. Provide electric strikes UL Listed as burglary-resistant.
- 3. Where required, provide electric strikes UL Listed for fire doors and frames.
- 4. Provide fail-secure type electric strikes, unless specified otherwise.

2017 Edition

5. Coordinate voltage and provide transformers and rectifiers for each strike as required.

2.13 POWER SUPPLIES FOR EXIT DEVICES

A. Manufacturers and Products:

1. Scheduled Manufacturer and Product: Schlage Electronics or Von Duprin PS900 series
2. Acceptable Manufacturers and Products: No Substitution

B. Requirements:

1. Provide power supplies, recommended and approved by manufacturer of electrified locking component, for operation of electrified locks, electrified exit devices, magnetic locks, electric strikes, and other components requiring power supply.
2. Provide appropriate quantity of power supplies necessary for proper operation of electrified locking components as recommended by manufacturer of electrified locking components with consideration for each electrified component using power supply, location of power supply, and approved wiring diagrams. Locate power supplies as directed by Architect.
3. **ALL ACCESS CONTROL POWER SUPPLIES AND OR CONTROL PANELS MUST BE TIED TO THE EMERGENCY GENERATOR ELECTRICAL CIRCUIT.**
4. Provide regulated and filtered 24 VDC power supply, and UL class 2 listed.
5. Options:
 - a. Provide power supply, where specified, with internal capability of charging sealed backup batteries 24 VDC, in addition to operating DC load.
 - b. Provide sealed batteries for battery back-up at each power supply where specified.
 - c. Provide keyed power supply cabinet.
6. Provide power supply in an enclosure, complete, and requiring 120VAC to fused input.
7. Provide power supply with emergency release terminals, where specified, that allow release of all devices upon activation of fire alarm system complete with fire alarm input for initiating “no delay” exiting mode.

2.14 POWER SUPPLIES, MISC.

A. Manufacturers and Products:

1. Scheduled Manufacturer and Product: Schlage Electronics or Von Duprin PS900 series

2. Acceptable Manufacturers and Products: Altronix

B. Requirements:

1. Provide power supplies, recommended and approved by manufacturer of electrified locking component, for operation of electrified locks, electrified exit devices, magnetic locks, electric strikes, and other components requiring power supply.
2. Provide appropriate quantity of power supplies necessary for proper operation of electrified locking components as recommended by manufacturer of electrified locking components with consideration for each electrified component using power supply, location of power supply, and approved wiring diagrams. Locate power supplies as directed by Architect.
3. **ALL ACCESS CONTROL POWER SUPPLIES AND OR CONTROL PANELS MUST BE TIED TO THE EMERGENCY GENERATOR ELECTRICAL CIRCUIT.**
4. Provide regulated and filtered 24 VDC power supply, and UL class 2 listed.
5. Options:
 - a. Provide power supply, where specified, with internal capability of charging sealed backup batteries 24 VDC, in addition to operating DC load.
 - b. Provide sealed batteries for battery back-up at each power supply where specified.
 - c. Provide keyed power supply cabinet.
6. Provide power supply in an enclosure, complete, and requiring 120VAC to fused input.
7. Provide power supply with emergency release terminals, where specified, that allow release of all devices upon activation of fire alarm system complete with fire alarm input for initiating “no delay” exiting mode.

2.15 CYLINDERS

A. Manufacturer and Product:

1. Scheduled Manufacturer and Product:
 - a. Interior, Non-Access Control Openings: Schlage Everest 29, No Substitute
 - b. Exterior/Access Control Openings: Schlage PrimusXP-29, No Substitute

B. Requirements: Provide cylinders/cores complying with the following requirements.

1. Cylinders/cores compliant with ANSI/BHMA A156.5; latest revision, Section 12, Grade 1; permanent cylinders; cylinder face finished to match lockset, manufacturer’s series as indicated.

2017 Edition

- C. Primus Cylinders: Where indicated, provide “Primus” cylinders/cores with “dual-locking mechanism” with interlocking finger pin(s) to check for patented features on keys.
- D. Nickel silver bottom pins.
 - 1. Identification:
- E. Mark permanent cylinders/cores and keys with applicable blind code per DHI publication “Keying Systems and Nomenclature” for identification. Blind code marks shall not include actual key cuts.
- F. Identification stamping provisions must be approved by the Architect and Owner.
- G. Failure to comply with stamping requirements shall be cause for replacement of cylinders/cores involved at no additional cost to Owner.
- H. Forward 0 bitted cylinders/cores to Owner, separately from keys, by means as directed by Owner.
- I. Ensure that at no time, the General Contractor or sub-contractor has possession of the permanent keys.
- J. Replaceable Construction Cores.
 - 1. Provide temporary construction cores replaceable by permanent cores, furnished in accordance with the following requirements.
 - a. 30 construction change keys.
 - b. For all openings including access control openings
 - 2. Owner or Owner’s Representative will replace temporary construction cores with permanent cores.

2.16 KEYING

- A. Keying System: Factory registered, complying with guidelines in ANSI/BHMA A156.28, incorporating decisions made at keying conference.
- B. Keying Requirements – General
 - 1. Provide keying system capable of multiplex master keying.
 - 2. Permanent cylinders/cores keyed by the manufacturer according to the following key system.
- C. Keying system as directed by the Owner.

2017 Edition

- D. Forward biting list and keys separately from cylinders, by means as directed by Owner. Failure to comply with forwarding requirements shall be cause for replacement of cylinders/cores involved at no additional cost to Owner.
- E. Key Features: Provide keys with the following features.
 - 1. Patent Protection: Keys and blanks protected by one or more utility patent(s)
 - 2. Geographically Exclusive: Where “Primus XP” cylinders/cores are indicated, provide geographically exclusive key system complying with the following restrictions.
- F. Key Material: Nickel silver; minimum thickness of .107-inch (2.3mm)
- G. Stamp keys with Owner’s unique key system facility code as established by the manufacturer; key symbol and embossed or stamped with “DO NOT DUPLICATE” along with the “PATENTED” or patent number to enforce the patent protection.
- H. Failure to comply with stamping requirements shall be cause for replacement of keys involved at no additional cost to Owner.
 - 1. Quantity: Furnish in the following quantities.
 - a. Change (Day) Keys: 3 per cylinder/core.

2.17 SURFACE DOOR CLOSERS

- A. Manufacturer and Product: LCN 4040XP series. No Substitute
- B. Requirements:
 - 1. Provide door closers conforming to ANSI/BHMA A156.4 Grade 1 requirements by BHMA certified independent testing laboratory. ISO 9000 certify closers. Stamp units with date of manufacture code.
 - 2. Provide door closers with fully hydraulic, full rack and pinion action with high strength cast iron cylinder, and full complement bearings at shaft.
 - 3. Cylinder Body: 1-1/2 inch (38 mm) diameter with 3/4 inch (19 mm) diameter double heat-treated pinion journal.
 - 4. Hydraulic Fluid: Fireproof, passing requirements of UL10C, and requiring no seasonal closer adjustment for temperatures ranging from 120 degrees F to -30 degrees F.
 - 5. Spring Power: Continuously adjustable over full range of closer sizes, and providing reduced opening force as required by accessibility codes and standards.
 - 6. Hydraulic Regulation: By tamper-proof, non-critical valves, with separate adjustment for latch speed, general speed, and backcheck.

2017 Edition

7. Provide closers with solid forged steel main arms and factory assembled heavy-duty forged forearms for parallel arm closers.
8. Pressure Relief Valve (PRV) Technology: Not permitted.
9. Finish for Closer Cylinders, Arms, Adapter Plates, and Metal Covers: Powder coating finish which has been certified to exceed 100 hours salt spray testing as described in ANSI Standard A156.4 and ASTM B117, or has special rust inhibitor (SRI).
10. Provide special templates, drop plates, mounting brackets, or adapters for arms as required for details, overhead stops, and other door hardware items interfering with closer mounting.

2.18 ELECTRO-HYDRAULIC AUTOMATIC OPERATORS [MOST TRAFFIC WILL BE MANUAL (NOT USING AUTO)]

A. Manufacturers and Products:

1. Scheduled Manufacturer and Product: LCN 4600 series
2. Acceptable Manufacturers and Products: No Substitution.

B. Requirements:

1. Provide low energy automatic operator units with hydraulic closer complying with ANSI A156.19.
2. Hydraulic Fluid: Fireproof, passing requirements of UL10C, and requiring no seasonal closer adjustment for temperatures ranging from 120 degrees F to -30 degrees F.
3. Provide units with conventional door closer opening and closing forces unless power operator motor is activated. Provide door closer assembly with adjustable spring size, back-check, and opening and closing speed adjustment valves to control door
4. Provide units with on/off switch for manual operation, motor start up delay, vestibule interface delay, electric lock delay, and door hold open delay.
5. Provide units with conventional door closer opening and closing forces unless power operator motor is activated. Provide door closer assembly with adjustable spring size, back-check valve, sweep valve, latch valve to control door.
6. Provide drop plates, brackets, or adapters for arms as required for details.
7. Provide hard-wired actuator switches for operation as specified.
8. Provide weather-resistant actuators at exterior applications.
9. Provide key switches with LED's, recommended and approved by manufacturer of automatic operator as required for function described in operation description of hardware group below. Cylinders: Refer to “KEYING” article, herein.
10. Provide complete assemblies of controls, switches, power supplies, relays, and parts/material recommended and approved by manufacturer of automatic operator for each individual leaf. Actuators control both doors simultaneously

2017 Edition

at pairs. Sequence operation of exterior and vestibule doors with automatic operators to allow ingress or egress through both sets of openings as directed by Architect. Locate actuators, key switches, and other controls as directed by Architect.

11. Provide units with vestibule inputs that allow sequencing operation of two units, and SPDT relay for interfacing with latching or locking devices.

2.19 ELECTRO-MECHANICAL AUTOMATIC OPERATORS [MOST TRAFFIC WILL BE AUTOMATIC]

A. Manufacturers and Products:

1. Scheduled Manufacturer and Product: LCN Senior Swing.
2. Acceptable Manufacturers and Products: No Substitution.

B. Requirements:

1. Provide low energy automatic operator units that are electro-mechanical design complying with ANSI A156.19.
 - a. Opening: Powered by DC motor working through reduction gears.
 - b. Closing: Spring force.
 - c. Manual, hydraulic, or chain drive closers: Not permitted.
 - d. Operation: Motor is off when door is in closing mode. Door can be manually operated with power on or off without damage to operator. Provide variable adjustments, including opening and closing speed adjustment.
 - e. Cover: Aluminum.
2. Provide units with manual off/auto/hold-open switch, push and go function to activate power operator, vestibule interface delay, electric lock delay, hold-open delay adjustable from 2 to 30 seconds, and logic terminal to interface with accessories, mats, and sensors.
3. Provide drop plates, brackets, or adapters for arms as required to suit details.
4. Provide hard-wired motion sensors and/or actuator switches for operation as specified. Provide weather-resistant actuators at exterior applications.
5. Provide key switches, with LED's, recommended and approved by manufacturer of automatic operator as required for function as described in operation description of hardware sets. Cylinders: Refer to “KEYING” article, herein.
6. Provide complete assemblies of controls, switches, power supplies, relays, and parts/material recommended and approved by manufacturer of automatic operator for each individual leaf. Actuators control both doors simultaneously at pairs. Sequence operation of exterior and vestibule doors with automatic operators to allow ingress or egress through both sets of openings as directed by Architect. Locate actuators, key switches, and other controls as directed by Architect.

2017 Edition

7. Provide units with inputs for smoke evacuation doors, where specified, which allow doors to power open upon fire alarm activation and hold open indefinitely or until fire alarm is reset, presence detector input, which prevents closed door from opening or door that is fully opened from closing, hold open toggle input, which allows remote activation for indefinite hold open and close second time input is activated, vestibule inputs, which allow sequencing operation of two units, and SPDT relay for interfacing with latching or locking devices.

2.20 DOOR TRIM

A. Manufacturers:

1. Scheduled Manufacturer: Ives.
2. Acceptable Manufacturers: Rockwood.

B. Requirements:

1. Provide push plates 4 inches (102 mm) wide by 16 inches (406 mm) high by 0.050 inch (1 mm) thick and beveled 4 edges. Where width of door stile prevents use of 4 inches (102 mm) wide plate, adjust width to fit.
2. Provide push bars of solid bar stock, diameter and length as scheduled. Provide push bars of sufficient length to span from center to center of each stile. Where required, mount back to back with pull.
3. Provide offset pulls of solid bar stock, diameter and length as scheduled. Where required, mount back to back with push bar.
4. Provide flush pulls as scheduled. Where required, provide back-to-back mounted model.
5. Provide pulls of solid bar stock, diameter and length as scheduled. Where required, mount back to back with push bar.
6. Provide pull plates 4 inches (102 mm) wide by 16 inches (406 mm) high by 0.050 inch (1 mm) thick, beveled 4 edges, and prepped for pull. Where width of door stile prevents use of 4 inches (102 mm) wide plate, adjust width to fit.
7. Provide wire pulls of solid bar stock, diameter and length as scheduled.
8. Provide decorative pulls as scheduled. Where required, mount back to back with pull.

2.21 PROTECTION PLATES

A. Manufacturers:

1. Scheduled Manufacturer: Ives.
2. Acceptable Manufacturers: Rockwood.

B. Requirements:

1. Provide kick plates, mop plates, and armor plates minimum of 0.050 inch (1 mm) thick as scheduled. Furnish with sheet metal or wood screws, finished to match plates.
2. Sizes of plates:
 - a. Kick Plates: 10 inches (254 mm) high by 2 inches (51 mm) less width of door on single doors, 1 inch (25 mm) less width of door on pairs
 - b. Mop Plates: 4 inches (102 mm) high by 2 inches (51 mm) less width of door on single doors, 1 inch (25 mm) less width of door on pairs
 - c. Armor Plates: 36 inches (914 mm) high by 2 inches (51 mm) less width of door on single doors, 1 inch (25 mm) less width of door on pairs

2.22 OVERHEAD STOPS AND OVERHEAD STOP/HOLDERS

A. Manufacturers:

1. Scheduled Manufacturers: Glynn-Johnson
2. Acceptable Manufacturers: Rixson

B. Requirements:

1. Provide heavy duty concealed mounted overhead stop or holder as specified for exterior and interior vestibule single acting doors.
2. Provide heavy duty concealed mounted overhead stop or holder as specified for double acting doors.
3. Provide heavy or medium duty and concealed or surface mounted overhead stop or holder for interior doors as specified. Provide medium duty surface mounted overhead stop for interior doors and at any door that swings more than 140 degrees before striking wall, open against equipment, casework, sidelights, and where conditions do not allow wall stop or floor stop presents tripping hazard.
4. Where overhead holders are specified provide friction type at doors without closer and positive type at doors with closer.

2.23 DOOR STOPS AND HOLDERS

A. Manufacturers:

1. Scheduled Manufacturer: Ives.
2. Acceptable Manufacturers: Rockwood.

- B. Provide door stops at each door leaf:
1. Provide wall stops wherever possible. Provide convex type where mortise type locks are used and concave type where cylindrical type locks are used.
 2. Where a wall stop cannot be used, provide universal floor stops for low or high rise options.
 3. Where wall or floor stop cannot be used, provide medium duty surface mounted overhead stop.

2.24 THRESHOLDS, SEALS, DOOR SWEEPS, AUTOMATIC DOOR BOTTOMS, AND GASKETING

A. Manufacturers:

1. Scheduled Manufacturer: Zero.
2. Acceptable Manufacturers: National Guard

B. Requirements:

1. Provide thresholds, weatherstripping (including door sweeps, seals, astragals) and gasketing systems (including smoke, sound, and light) as specified and per architectural details. Match finish of other items.
2. Size of thresholds:
 - a. Saddle Thresholds: 1/2 inch (13 mm) high by jamb width by door width
 - b. Bumper Seal Thresholds: 1/2 inch (13 mm) high by 5 inches (127 mm) wide by door width
3. Provide door sweeps, seals, astragals, and auto door bottoms only of type where resilient or flexible seal strip is easily replaceable and readily available.

2.25 SILENCERS

A. Manufacturers:

1. Scheduled Manufacturer: Ives.
2. Acceptable Manufacturers: Rockwood.

B. Requirements:

1. Provide "push-in" type silencers for hollow metal or wood frames.
2. Provide one silencer per 30 inches (762 mm) of height on each single frame, and two for each pair frame.
3. Omit where gasketing is specified.

2.26 MAGNETIC HOLDERS

A. Manufacturers:

1. Scheduled Manufacturer: LCN.
2. Acceptable Manufacturers: Rixson.

B. Requirements:

1. Provide wall or floor mounted electromagnetic door release as specified with minimum of 25 pounds of holding force. Coordination projection of holder and armature with other hardware and wall conditions to ensure that door sits parallel to wall when fully open. Wire magnetic holders on fire-rated doors into the fire control panel for fail-safe operation.

2.27 DOOR VIEWERS

A. Manufacturers:

1. Scheduled Manufacturer: Ives.
2. Acceptable Manufacturers: Rockwood.

- ### B. Provide appropriate door viewer for door type and rating with minimum of 180-degree view area.

2.28 FINISHES

A. Finish: BHMA 626/652 (US26D); except:

1. Hinges at Exterior Doors: BHMA 630 (US32D)
2. Continuous Hinges: BHMA 630 (US32D)
3. Push Plates, Pulls, and Push Bars: BHMA 630 (US32D)
4. Protection Plates: BHMA 630 (US32D)
5. Overhead Stops and Holders: BHMA 630 (US32D)
6. Door Closers: Powder Coat to Match
7. Wall Stops: BHMA 630 (US32D)
8. Latch Protectors: BHMA 630 (US32D)
9. Weatherstripping: Clear Anodized Aluminum
10. Thresholds: Mill Finish Aluminum

PART 3 - EXECUTION

3.1 EXAMINATION

- A. Prior to installation of hardware, examine doors and frames, with Installer present, for compliance with requirements for installation tolerances, labeled fire-rated door assembly construction, wall and floor construction, and other conditions affecting performance.
- B. Existing Door and Frame Compatibility: Field verify existing doors and frames receiving new hardware and existing conditions receiving new openings. Verify that new hardware is compatible with existing door and frame preparation and existing conditions.
- C. Examine roughing-in for electrical power systems to verify actual locations of wiring connections before electrified door hardware installation.
- D. Proceed with installation only after unsatisfactory conditions have been corrected.

3.2 PREPARATION

- A. Where on-site modification of doors and frames is required:
 - 1. Remove existing hardware being replaced, tag, and store according to contract documents.
 - 2. Field modify and prepare existing door and frame for new hardware being installed.
 - 3. When modifications are exposed to view, use concealed fasteners, when possible.
 - 4. Prepare hardware locations in accordance with:
 - a. Steel Doors and Frames: For surface applied door hardware, drill and tap doors and frames according to ANSI/SDI A250.6.
 - b. Wood Doors: DHI WDHS.5 "Recommended Hardware Reinforcement Locations for Mineral Core Wood Flush Doors."
 - c. Doors in rated assemblies: NFPA 80 for restrictions on on-site door hardware preparation.

3.3 INSTALLATION

- A. Mounting Heights: Mount door hardware units at heights to comply with the following, unless otherwise indicated or required to comply with governing regulations.
 - 1. Standard Steel Doors and Frames: ANSI/SDI A250.8.

2017 Edition

2. Custom Steel Doors and Frames: HMMA 831.
 3. Wood Doors: DHI WDHS.3, "Recommended Locations for Architectural Hardware for Wood Flush Doors."
- B. Install each hardware item in compliance with manufacturer's instructions and recommendations, using only fasteners provided by manufacturer.
- C. Do not install surface mounted items until finishes have been completed on substrate. Protect all installed hardware during painting.
- D. Set units level, plumb and true to line and location. Adjust and reinforce attachment substrate as necessary for proper installation and operation.
- E. Drill and countersink units that are not factory prepared for anchorage fasteners. Space fasteners and anchors according to industry standards.
- F. Install operating parts so they move freely and smoothly without binding, sticking, or excessive clearance.
- G. Hinges: Install types and in quantities indicated in door hardware schedule but not fewer than quantity recommended by manufacturer for application indicated or one hinge for every 30 inches (750 mm) of door height, whichever is more stringent, unless other equivalent means of support for door, such as spring hinges or pivots, are provided.
- H. Intermediate Offset Pivots: Where offset pivots are indicated, provide intermediate offset pivots in quantities indicated in door hardware schedule but not fewer than one intermediate offset pivot per door and one additional intermediate offset pivot for every 30 inches (750 mm) of door height greater than 90 inches (2286 mm).
- I. Lock Cylinders: Install construction cores to secure building and areas during construction period.
1. Furnish permanent cores to Owner for installation.
- J. Lead Protection: Lead wrap hardware penetrating lead-lined doors. Levers and roses to be lead lined. Apply kick and armor plates on lead-lined doors with adhesive as recommended by manufacturer.
- K. Wiring: Coordinate with Division 26, ELECTRICAL sections for:
1. Conduit, junction boxes and wire pulls.
 2. Connections to and from power supplies to electrified hardware.
 3. Connections to fire/smoke alarm system and smoke evacuation system.
 4. Connection of wire to door position switches and wire runs to central room or area, as directed by Architect.
 5. Testing and labeling wires with Architect's opening number.

2017 Edition

- L. Door Closers: Mount closers on room side of corridor doors, inside of exterior doors, and stair side of stairway doors from corridors. Closers shall not be visible in corridors, lobbies and other public spaces unless approved by Architect.
- M. Closer/holders: Mount closer/holders on room side of corridor doors, inside of exterior doors, and stair side of stairway doors.
- N. Power Supplies: Locate power supplies as indicated or, if not indicated, above accessible ceilings or in equipment room, or alternate location as directed by Architect.
- O. Thresholds: Set thresholds in full bed of sealant complying with requirements specified in Division 07 Section "Joint Sealants."
- P. Stops: Provide floor stops for doors unless wall or other type stops are indicated in door hardware schedule. Do not mount floor stops where they may impede traffic or present tripping hazard.
- Q. Perimeter Gasketing: Apply to head and jamb, forming seal between door and frame.
- R. Meeting Stile Gasketing: Fasten to meeting stiles, forming seal when doors are closed.
- S. Door Bottoms: Apply to bottom of door, forming seal with threshold when door is closed.

3.4 FIELD QUALITY CONTROL

- A. Architectural Hardware Consultant: Engage qualified independent Architectural Hardware Consultant to perform inspections and to prepare inspection reports.
 - 1. Architectural Hardware Consultant will inspect door hardware and state in each report whether installed work complies with or deviates from requirements, including whether door hardware is properly installed and adjusted.

3.5 ADJUSTING

- A. Initial Adjustment: Adjust and check each operating item of door hardware and each door to ensure proper operation or function of every unit. Replace units that cannot be adjusted to operate as intended. Adjust door control devices to compensate for final operation of heating and ventilating equipment and to comply with referenced accessibility requirements.

2017 Edition

1. Spring Hinges: Adjust to achieve positive latching when door is allowed to close freely from an open position of 30 degrees.
 2. Electric Strikes: Adjust horizontal and vertical alignment of keeper to properly engage lock bolt.
 3. Door Closers: Adjust sweep period to comply with accessibility requirements and requirements of authorities having jurisdiction.
- B. Occupancy Adjustment: Approximately six months after date of Substantial Completion, Supplier's Architectural Hardware Consultant shall examine and readjust each item of door hardware, including adjusting operating forces, as necessary to ensure function of doors, door hardware, and electrified door hardware.

3.6 CLEANING AND PROTECTION

- A. Clean adjacent surfaces soiled by door hardware installation.
- B. Clean operating items as necessary to restore proper function and finish.
- C. Provide final protection and maintain conditions that ensure door hardware is without damage or deterioration at time of Substantial Completion.

3.7 DEMONSTRATION

- A. Provide training for Owner's maintenance personnel to adjust, operate, and maintain door hardware and door hardware finishes. Refer to Division 01 Section "Demonstration and Training."

3.8 DOOR HARDWARE SCHEDULE

- A. Locksets, exit devices, and other hardware items are referenced in the following hardware sets for series, type and function. Refer to the above-specifications for special features, options, cylinders/keying, and other requirements.
- B. Hardware Sets:

BUILDING STANDARDS – APPENDIX “A” MASTER DOOR HARDWARE
 University of Miami SPECIFICATION 08 70 00

2017 Edition

Hardware Group No. 01 - ACCESS EXTERIOR ELECTRIC RM, 6'0 X 8'0

Provide each PR door(s) with the following:

Qty		Description	Catalog Number	Finish	Mfr
8	EA	HW HINGE	5BB1HW 4.5 X 4.5 NRP	630	IVE
1	EA	POWER TRANSFER	EPT10	689	VON
1	EA	KEYED FIRE RATED REMOVABLE MULLION	KR9954-STAB	689	VON
1	EA	PANIC HARDWARE	RX-LC-HH-98-EO-SNB	626	VON
1	EA	ELEC PANIC HARDWARE	RX-LC-HH-98-EO-SNB	626	VON
1	EA	ELEC EXIT DEVICE TRIM	AD-400-993R-70-MS-ATH-PD BY DIV 28	626	SCE
1	EA	MORTISE CYLINDER	20-061-ICX	626	SCH
1	EA	PRIMUS K-I-L CYL.	20-750-XP EV29 T	626	SCH
1	EA	PRIMUS CORE	20-740-XP EV29 T	626	SCH
2	EA	SURFACE CLOSER	4040XP SCUSH	689	LCN
2	EA	KICK PLATE	8400 10" X 2" LDW B-CS	630	IVE
1	EA	GASKETING	328AA	AA	ZER
2	EA	DOOR BOTTOM	321AA6	AA	ZER
1	EA	THRESHOLD	566A-MSLA-10	A	ZER
1	EA	RAIN DRIP	142A	A	ZER
2	EA	DOOR CONTACT	679-05HM DIV 28	BLK	SCE

Hardware Group No. 02 - ACCESS EXTERIOR GENERATOR, 6'0 X 8'0

Provide each PR door(s) with the following:

Qty		Description	Catalog Number	Finish	Mfr
8	EA	HINGE	5BB1 4.5 X 4.5 NRP	630	IVE
2	EA	SURFACE BOLT	SB360 12" T	604	IVE
1	EA	ELEC CLASSROOM LOCK	AD-400-CY-70-MS-8AT ATH-PD BY DIV 28	626	SCE
1	EA	PRIMUS K-I-L CYL.	20-750-XP EV29 T	626	SCH
2	EA	SURFACE CLOSER	4040XP SCUSH	689	LCN
2	EA	KICK PLATE	8400 10" X 1" LDW B-CS	630	IVE
1	EA	GASKETING	328AA	AA	ZER
2	EA	DOOR BOTTOM	321AA6	AA	ZER
1	EA	RAIN DRIP	142A	A	ZER

FLAT ASTRAGAL BY OTHERS

BUILDING STANDARDS – APPENDIX “A” MASTER DOOR HARDWARE
 University of Miami SPECIFICATION 08 70 00

2017 Edition

Hardware Group No. 03 - ACCESS EXTERIOR ELECTRIC RM, 3'0 X 8'0

Provide each SGL door(s) with the following:

Qty		Description	Catalog Number	Finish	Mfr
4	EA	HINGE	5BB1 4.5 X 4.5 NRP	630	IVE
1	EA	ELEC FIRE EXIT HARDWARE	RX-LC-HH-98-EO-F-SNB	626	VON
1	EA	ELEC EXIT DEVICE TRIM	AD-400-993R-70-MS-ATH-PD BY DIV 28	626	SCE
1	EA	PRIMUS K-I-L CYL.	20-750-XP EV29 T	626	SCH
1	EA	SURFACE CLOSER	4040XP SCUSH	689	LCN
1	EA	KICK PLATE	8400 10" X 2" LDW B-CS	630	IVE
1	EA	GASKETING	328AA	AA	ZER
1	EA	DOOR BOTTOM	321AA6	AA	ZER
1	EA	THRESHOLD	566A-MSLA-10	A	ZER

Hardware Group No. 04 - ACCESS ELECTRIC ROOM RATED, 3'0 X 8'0

Provide each SGL door(s) with the following:

Qty		Description	Catalog Number	Finish	Mfr
4	EA	HINGE	5BB1 4.5 X 4.5	652	IVE
1	EA	ELEC CLASSROOM LOCK	AD-400-CY-70-MS-ATH-PD BY DIV 28	626	SCE
1	EA	PRIMUS K-I-L CYL.	20-750-XP EV29 T	626	SCH
1	EA	SURFACE CLOSER	4040XP SCUSH	689	LCN
1	EA	KICK PLATE	8400 10" X 2" LDW B-CS	630	IVE
1	EA	GASKETING	328AA	AA	ZER
1	EA	THRESHOLD	566A-MSLA-10	A	ZER

Hardware Group No. 05 - ACCESS ELECTRIC ROOM RATED, 3'0 X 8'0

Provide each SGL door(s) with the following:

Qty		Description	Catalog Number	Finish	Mfr
4	EA	HINGE	5BB1 4.5 X 4.5	652	IVE
1	EA	ELEC CLASSROOM LOCK	AD-400-CY-70-MS-ATH-PD BY DIV 28	626	SCE
1	EA	PRIMUS K-I-L CYL.	20-750-XP EV29 T	626	SCH
1	EA	SURFACE CLOSER	4040XP EDA	689	LCN
1	EA	KICK PLATE	8400 10" X 2" LDW B-CS	630	IVE
1	EA	WALL STOP	WS407CVX	630	IVE
1	EA	GASKETING	328AA	AA	ZER
1	EA	THRESHOLD	PER SILL DETAIL	A	ZER

BUILDING STANDARDS – APPENDIX “A” MASTER DOOR HARDWARE
 University of Miami SPECIFICATION 08 70 00

2017 Edition

Hardware Group No. 06 - ACCESS STORAGE, JANITOR.NON- RATED, 3'0 X 7'0

Provide each SGL door(s) with the following:

Qty		Description	Catalog Number	Finish	Mfr
3	EA	HINGE	5BB1 4.5 X 4.5	652	IVE
1	EA	ELEC CLASSROOM LOCK	AD-400-CY-70-MS-ATH-PD BY DIV 28	626	SCE
1	EA	PRIMUS K-I-L CYL.	20-750-XP EV29 T	626	SCH
1	EA	SURFACE CLOSER	4040XP SCUSH	689	LCN
1	EA	KICK PLATE	8400 10" X 2" LDW B-CS	630	IVE
1	EA	THRESHOLD	PER SILL DETAIL	A	ZER
3	EA	SILENCER	SR64	GRY	IVE

Hardware Group No. 07 - ACCESS STORAGE, JANITOR.NON- RATED, 3'0 X 8'0

Provide each SGL door(s) with the following:

Qty		Description	Catalog Number	Finish	Mfr
4	EA	HINGE	5BB1 4.5 X 4.5	652	IVE
1	EA	ELEC CLASSROOM LOCK	AD-400-CY-70-MS-ATH-PD BY DIV 28	626	SCE
1	EA	PRIMUS K-I-L CYL.	20-750-XP EV29 T	626	SCH
1	EA	SURFACE CLOSER	4040XP SCUSH	689	LCN
1	EA	KICK PLATE	8400 10" X 2" LDW B-CS	630	IVE
1	EA	THRESHOLD	PER SILL DETAIL	A	ZER
3	EA	SILENCER	SR64	GRY	IVE

Hardware Group No. 08 - ACCESS STORAGE, JANITOR. NON- RATED, 3'0 X 8'0

Provide each SGL door(s) with the following:

Qty		Description	Catalog Number	Finish	Mfr
4	EA	HINGE	5BB1 4.5 X 4.5	652	IVE
1	EA	ELEC CLASSROOM LOCK	AD-400-CY-70-MS-ATH-PD BY DIV 28	626	SCE
1	EA	PRIMUS K-I-L CYL.	20-750-XP EV29 T	626	SCH
1	EA	SURFACE CLOSER	4040XP RW/PA	689	LCN
1	EA	KICK PLATE	8400 10" X 2" LDW B-CS	630	IVE
1	EA	WALL STOP	WS407CVX	630	IVE
1	EA	THRESHOLD	PER SILL DETAIL	A	ZER
3	EA	SILENCER	SR64	GRY	IVE

BUILDING STANDARDS – APPENDIX “A” MASTER DOOR HARDWARE
 University of Miami SPECIFICATION 08 70 00

2017 Edition

Hardware Group No. 09 - ACCESS STORAGE, JANITOR. NON- RATED, 4'0 X 8'0

Provide each SGL door(s) with the following:

Qty		Description	Catalog Number	Finish	Mfr
4	EA	HW HINGE	5BB1HW 5 X 4.5	652	IVE
1	EA	ELEC CLASSROOM LOCK	AD-400-CY-70-MS-ATH-PD BY DIV 28	626	SCE
1	EA	PRIMUS K-I-L CYL.	20-750-XP EV29 T	626	SCH
1	EA	SURFACE CLOSER	4040XP RW/PA	689	LCN
1	EA	KICK PLATE	8400 10" X 2" LDW B-CS	630	IVE
1	EA	WALL STOP	WS407CVX	630	IVE
1	EA	THRESHOLD	PER SILL DETAIL	A	ZER
3	EA	SILENCER	SR64	GRY	IVE

Hardware Group No. 10 - ACCESS JANITOR ROOM NON- RATED, 3'0 X 8'0

Provide each SGL door(s) with the following:

Qty		Description	Catalog Number	Finish	Mfr
4	EA	HINGE	5BB1 4.5 X 4.5	652	IVE
1	EA	ELEC CLASSROOM LOCK	AD-400-CY-70-MS-ATH-PD BY DIV 28	626	SCE
1	EA	PRIMUS K-I-L CYL.	20-750-XP EV29 T	626	SCH
1	EA	SURFACE CLOSER	4040XP EDA	689	LCN
1	EA	KICK PLATE	8400 10" X 2" LDW B-CS	630	IVE
1	EA	WALL STOP	WS407CVX	630	IVE
1	EA	THRESHOLD	PER SILL DETAIL	A	ZER
3	EA	SILENCER	SR64	GRY	IVE

Hardware Group No. 11 - ACCESS JANITOR ROOM NON- RATED, 4'0 X 8'0

Provide each SGL door(s) with the following:

Qty		Description	Catalog Number	Finish	Mfr
4	EA	HW HINGE	5BB1HW 5 X 4.5	652	IVE
1	EA	ELEC CLASSROOM LOCK	AD-400-CY-70-MS-ATH-PD BY DIV 28	626	SCE
1	EA	PRIMUS K-I-L CYL.	20-750-XP EV29 T	626	SCH
1	EA	SURFACE CLOSER	4040XP EDA	689	LCN
1	EA	KICK PLATE	8400 10" X 2" LDW B-CS	630	IVE
1	EA	WALL STOP	WS407CVX	630	IVE

BUILDING STANDARDS – APPENDIX “A” MASTER DOOR HARDWARE
 University of Miami SPECIFICATION 08 70 00

2017 Edition

1	EA	THRESHOLD	PER SILL DETAIL	A	ZER
3	EA	SILENCER	SR64	GRY	IVE

Hardware Group No. 12 - ACCESS STORAGE, JANITOR. RATED, 3'0 X 8'0

Provide each SGL door(s) with the following:

Qty		Description	Catalog Number	Finish	Mfr
4	EA	HINGE	5BB1 4.5 X 4.5	652	IVE
1	EA	ELEC CLASSROOM LOCK	AD-400-CY-70-MS-ATH-PD BY DIV 28	626	SCE
1	EA	PRIMUS K-I-L CYL.	20-750-XP EV29 T	626	SCH
1	EA	SURFACE CLOSER	4040XP SCUSH	689	LCN
1	EA	KICK PLATE	8400 10" X 2" LDW B-CS	630	IVE
1	EA	GASKETING	328AA	AA	ZER
1	EA	THRESHOLD	PER SILL DETAIL	A	ZER

Hardware Group No. 13 - ACCESS STORAGE, JANITOR. RATED, 4'0 X 7'0

Provide each SGL door(s) with the following:

Qty		Description	Catalog Number	Finish	Mfr
3	EA	HW HINGE	5BB1HW 5 X 4.5	652	IVE
1	EA	ELEC CLASSROOM LOCK	AD-400-CY-70-MS-ATH-PD BY DIV 28	626	SCE
1	EA	PRIMUS K-I-L CYL.	20-750-XP EV29 T	626	SCH
1	EA	SURFACE CLOSER	4040XP SCUSH	689	LCN
1	EA	KICK PLATE	8400 10" X 2" LDW B-CS	630	IVE
1	EA	GASKETING	328AA	AA	ZER
1	EA	THRESHOLD	PER SILL DETAIL	A	ZER

Hardware Group No. 14 - ACCESS STORAGE, JANITOR. RATED, 3'6 X 7'0

Provide each SGL door(s) with the following:

Qty		Description	Catalog Number	Finish	Mfr
3	EA	HW HINGE	5BB1HW 5 X 4.5	652	IVE
1	EA	ELEC CLASSROOM LOCK	AD-400-CY-70-MS-ATH-PD BY DIV 28	626	SCE
1	EA	PRIMUS K-I-L CYL.	20-750-XP EV29 T	626	SCH
1	EA	SURFACE CLOSER	4040XP SCUSH	689	LCN

BUILDING STANDARDS – APPENDIX “A” MASTER DOOR HARDWARE
 University of Miami SPECIFICATION 08 70 00

2017 Edition

1	EA	KICK PLATE	8400 10" X 2" LDW B-CS	630	IVE
1	EA	GASKETING	328AA	AA	ZER
1	EA	THRESHOLD	PER SILL DETAIL	A	ZER

Hardware Group No. 15 - ACCESS STORAGE, JANITOR. RATED, 3'0 X 8'0

Provide each SGL door(s) with the following:

Qty		Description	Catalog Number	Finish	Mfr
4	EA	HINGE	5BB1 4.5 X 4.5	652	IVE
1	EA	ELEC CLASSROOM LOCK	AD-400-CY-70-MS-ATH-PD BY DIV 28	626	SCE
1	EA	PRIMUS K-I-L CYL.	20-750-XP EV29 T	626	SCH
1	EA	SURFACE CLOSER	4040XP SCUSH	689	LCN
1	EA	KICK PLATE	8400 10" X 2" LDW B-CS	630	IVE
1	EA	GASKETING	328AA	AA	ZER
1	EA	THRESHOLD	PER SILL DETAIL	A	ZER

Hardware Group No. 16 - ACCESS STORAGE. NON- RATED, 3'0 X 8'0

Provide each SGL door(s) with the following:

Qty		Description	Catalog Number	Finish	Mfr
4	EA	HINGE	5BB1 4.5 X 4.5	652	IVE
1	EA	ELEC CLASSROOM LOCK	AD-400-CY-70-MS-ATH-PD BY DIV 28	626	SCE
1	EA	PRIMUS K-I-L CYL.	20-750-XP EV29 T	626	SCH
1	EA	SURFACE CLOSER	4040XP RW/PA	689	LCN
1	EA	KICK PLATE	8400 10" X 2" LDW B-CS	630	IVE
1	EA	FLOOR STOP	FS436	626	IVE
1	EA	THRESHOLD	/ 438 AS REQUIRED PER SILL DETAIL	A	ZER
3	EA	SILENCER	SR64	GRY	IVE

Hardware Group No. 17 - ACCESS STORAGE. NON- RATED, 3'0 X 8'0

Provide each SGL door(s) with the following:

Qty		Description	Catalog Number	Finish	Mfr
4	EA	HINGE	5BB1 4.5 X 4.5	652	IVE

BUILDING STANDARDS – APPENDIX “A” MASTER DOOR HARDWARE
 University of Miami SPECIFICATION 08 70 00

2017 Edition

1	EA	ELEC CLASSROOM LOCK	AD-400-CY-70-MS-ATH-PD BY DIV 28	626	SCE
1	EA	PRIMUS K-I-L CYL.	20-750-XP EV29 T	626	SCH
1	EA	SURFACE CLOSER	4040XP RW/PA	689	LCN
1	EA	KICK PLATE	8400 10" X 2" LDW B-CS	630	IVE
1	EA	FLOOR STOP	FS436	626	IVE
			/ 438 AS REQUIRED		
1	EA	GASKETING	328AA	AA	ZER
1	EA	THRESHOLD	PER SILL DETAIL	A	ZER

Hardware Group No. 18 - ACCESS STORAGE. NON- RATED, 3'0 X 8'0

Provide each SGL door(s) with the following:

Qty		Description	Catalog Number	Finish	Mfr
4	EA	HINGE	5BB1 4.5 X 4.5	652	IVE
1	EA	ELEC CLASSROOM LOCK	AD-400-CY-70-MS-ATH-PD BY DIV 28	626	SCE
1	EA	PRIMUS K-I-L CYL.	20-750-XP EV29 T	626	SCH
1	EA	SURFACE CLOSER	4040XP RW/PA	689	LCN
1	EA	KICK PLATE	8400 10" X 2" LDW B-CS	630	IVE
1	EA	WALL STOP	WS407CVX	630	IVE
1	EA	THRESHOLD	PER SILL DETAIL	A	ZER
3	EA	SILENCER	SR64	GRY	IVE

Hardware Group No. 19 - ACCESS STORAGE. NON- RATED, 3'0 X 8'0

Provide each SGL door(s) with the following:

Qty		Description	Catalog Number	Finish	Mfr
4	EA	HINGE	5BB1 4.5 X 4.5	652	IVE
1	EA	ELEC CLASSROOM LOCK	AD-400-CY-70-MS-ATH-PD BY DIV 28	626	SCE
1	EA	PRIMUS K-I-L CYL.	20-750-XP EV29 T	626	SCH
1	EA	SURFACE CLOSER	4040XP EDA	689	LCN
1	EA	KICK PLATE	8400 10" X 2" LDW B-CS	630	IVE
1	EA	WALL STOP	WS407CVX	630	IVE
1	EA	THRESHOLD	PER SILL DETAIL	A	ZER
3	EA	SILENCER	SR64	GRY	IVE

BUILDING STANDARDS – APPENDIX “A” MASTER DOOR HARDWARE
 University of Miami SPECIFICATION 08 70 00

2017 Edition

Hardware Group No. 20 - ACCESS STORAGE. NON- RATED, 4'0 X 8'0

Provide each SGL door(s) with the following:

Qty		Description	Catalog Number	Finish	Mfr
4	EA	HW HINGE	5BB1HW 5 X 4.5	652	IVE
1	EA	ELEC CLASSROOM LOCK	AD-400-CY-70-MS-ATH-PD BY DIV 28	626	SCE
1	EA	PRIMUS K-I-L CYL.	20-750-XP EV29 T	626	SCH
1	EA	SURFACE CLOSER	4040XP EDA	689	LCN
1	EA	KICK PLATE	8400 10" X 2" LDW B-CS	630	IVE
1	EA	WALL STOP	WS407CVX	630	IVE
1	EA	THRESHOLD	PER SILL DETAIL	A	ZER
3	EA	SILENCER	SR64	GRY	IVE

Hardware Group No. 21 - ACCESS EXTERIOR- MECHANICAL, ELECTRICAL, NON- RATED,
 3'0 X 8'0

Provide each SGL door(s) with the following:

Qty		Description	Catalog Number	Finish	Mfr
4	EA	HINGE	5BB1 4.5 X 4.5 NRP	630	IVE
1	EA	ELEC CLASSROOM LOCK	AD-400-CY-70-MS-ATH-PD BY DIV 28	626	SCE
1	EA	PRIMUS K-I-L CYL.	20-750-XP EV29 T	626	SCH
1	EA	SURFACE CLOSER	4040XP SCUSH	689	LCN
1	EA	KICK PLATE	8400 10" X 2" LDW B-CS	630	IVE
1	EA	GASKETING	328AA	AA	ZER
1	EA	DOOR BOTTOM	321AA6	AA	ZER
1	EA	THRESHOLD	566A-MSLA-10	A	ZER
1	EA	RAIN DRIP	142A	A	ZER

HURRICANE COMPLIANT OPENING

BUILDING STANDARDS – APPENDIX “A” MASTER DOOR HARDWARE
 University of Miami SPECIFICATION 08 70 00

2017 Edition

Hardware Group No. 22 - ACCESS-HOLLOW METAL RATED SGL EXIT 3'0 X 7'0

Provide each SGL door(s) with the following:

Qty		Description	Catalog Number	Finish	Mfr
3	EA	HW HINGE	5BB1HW 4.5 X 4.5 NRP	630	IVE
1	EA	POWER TRANSFER	EPT10	689	VON
1	EA	ELEC FIRE EXIT HARDWARE	RX-LC-HH-98-EO-F-SNB	626	VON
1	EA	ELEC EXIT DEVICE TRIM	AD-300-993R-70-MS-ATH-PD BY DIV 28	626	SCE
1	EA	PRIMUS K-I-L CYL.	20-750-XP EV29 T	626	SCH
1	EA	SURFACE CLOSER	4040XP SCUSH	689	LCN
1	EA	KICK PLATE	8400 10" X 2" LDW B-CS	630	IVE
1	EA	GASKETING	328AA	AA	ZER
1	EA	THRESHOLD	65A-MSLA-10	A	ZER
1	EA	RAIN DRIP	142A	A	ZER

HURRICANE COMPLIANT OPENING

AD TRIM NEEDS TO BE SET TO FAILSAFE OVER 4 STORY OR LOCAL HEIGHT LIMIT
 FOR STAIRWELLS

Hardware Group No. 23 - ACCESS-HOLLOW METAL NON- RATED SGL EXIT 3'0 X 8'0

Provide each SGL door(s) with the following:

Qty		Description	Catalog Number	Finish	Mfr
4	EA	HW HINGE	5BB1HW 4.5 X 4.5 NRP	630	IVE
1	EA	POWER TRANSFER	EPT10	689	VON
1	EA	ELEC PANIC HARDWARE	RX-LC-HH-98-EO-SNB	626	VON
1	EA	ELEC EXIT DEVICE TRIM	AD-300-993R-70-MS-ATH-PD BY DIV 28	626	SCE
1	EA	PRIMUS K-I-L CYL.	20-750-XP EV29 T	626	SCH
1	EA	SURFACE CLOSER	4040XP EDA	689	LCN
1	EA	KICK PLATE	8400 10" X 2" LDW B-CS	630	IVE
1	EA	WALL STOP	WS443	626	IVE
1	EA	GASKETING	328AA	AA	ZER
1	EA	THRESHOLD	65A-MSLA-10	A	ZER

HURRICANE COMPLIANT OPENING

AD TRIM NEEDS TO BE SET TO FAILSAFE OVER 4 STORY OR LOCAL HEIGHT LIMIT
 FOR STAIRWELLS

BUILDING STANDARDS – APPENDIX “A” MASTER DOOR HARDWARE
 University of Miami SPECIFICATION 08 70 00

2017 Edition

Hardware Group No. 24 - FIRE RATED EXIT DEVICE NO LOCKING 3'0 X 8'0

Provide each SGL door(s) with the following:

Qty		Description	Catalog Number	Finish	Mfr
4	EA	HW HINGE	5BB1HW 4.5 X 4.5 NRP	630	IVE
1	EA	FIRE EXIT HARDWARE	98-L-BE-F-07	630	VON
1	EA	SURFACE CLOSER	4040XP EDA	689	LCN
1	EA	KICK PLATE	8400 10" X 2" LDW B-CS	630	IVE
1	EA	WALL STOP	WS407CVX	630	IVE
1	EA	GASKETING	328AA	AA	ZER
1	EA	THRESHOLD	PER SILL DETAIL	A	ZER

Hardware Group No. 25 - ACCESS-HOLLOW METAL NON- RATED SGL EXIT 3'0 X 8'0

Provide each SGL door(s) with the following:

Qty		Description	Catalog Number	Finish	Mfr
4	EA	HW HINGE	5BB1HW 4.5 X 4.5 NRP	630	IVE
1	EA	POWER TRANSFER	EPT10	689	VON
1	EA	ELEC PANIC HARDWARE	RX-LC-HH-98-EO-SNB	626	VON
1	EA	ELEC EXIT DEVICE TRIM	AD-300-993R-70-MS-ATH-PD BY DIV 28	626	SCE
1	EA	PRIMUS K-I-L CYL.	20-750-XP EV29 T	626	SCH
1	EA	SURFACE CLOSER	4040XP EDA	689	LCN
1	EA	KICK PLATE	8400 10" X 2" LDW B-CS	630	IVE
1	EA	WALL STOP	WS443	626	IVE
1	EA	GASKETING	328AA	AA	ZER
1	EA	THRESHOLD	65A-MSLA-10	A	ZER
1	EA	RAIN DRIP	142A	A	ZER

HURRICANE COMPLIANT OPENING

AD TRIM NEEDS TO BE SET TO FAILSAFE OVER 4 STORY OR LOCAL HEIGHT LIMIT
 FOR STAIRWELLS

BUILDING STANDARDS – APPENDIX “A” MASTER DOOR HARDWARE
 University of Miami SPECIFICATION 08 70 00

2017 Edition

Hardware Group No. 26 - CARD ACCESS-STOREFRONT WITH OPERATOR 6'0 X 8'0

Provide each PR door(s) with the following:

Qty		Description	Catalog Number	Finish	Mfr
8	EA	HW HINGE	5BB1HW 4.5 X 4.5 NRP	630	IVE
2	EA	POWER TRANSFER	EPT10	689	VON
1	EA	ELEC PANIC HARDWARE	RX-QEL+-HH-9847-EO-SNB	630	VON
1	EA	ELEC PANIC HARDWARE	RX-QEL+-HH-9847-NL-OP-110MD- SNB	630	VON
1	EA	RIM CYLINDER	20-057-ICX	626	SCH
1	EA	PRIMUS CORE	20-740-XP EV29 T	626	SCH
2	EA	CUSTOM PULL	PULL BY DOOR MANUFACTURER		
1	EA	SURF. AUTO OPERATOR	9553 REG2 MS	ANCLR	LCN
2	EA	ACTUATOR, WALL MOUNT	8310-853	630	LCN
2	EA	FLOOR STOP	FS444	626	IVE
1	EA	THRESHOLD	654A-MSLA-10	A	ZER
1	EA	MULTITECH READER	MTMS15 DIV 28	BLK	SCE
2	EA	DOOR CONTACT	679-05HM DIV 28	BLK	SCE
1	EA	POWER SUPPLY	PS902 900-2RS BY DIV 28	LGR	VON
1		BALANCE OF HARDWARE BY DOOR MANUFACTURER			

WIRING DIAGRAM BY HARDWARE SUPPLIER.

HURRICANE COMPLIANT OPENING

DOOR PULLS TO BE THRU-BOLTED.

- 1.) During business hours both outside and inside actuators are active (button pushed and doors open).
- 2.) After hours (time zones end), inside button always active 24/7. However outside button is inactive. Card has to be swiped in order to activate outside button. Once button is pushed door hardware will retract simultaneously with door opening. If button is not pushed after card is swiped door can be pulled open.

BUILDING STANDARDS – APPENDIX “A” MASTER DOOR HARDWARE
 University of Miami SPECIFICATION 08 70 00

2017 Edition

Hardware Group No. 27 - CARD ACCESS-STOREFRONT 6'0 X 8'0

Provide each PR door(s) with the following:

Qty		Description	Catalog Number	Finish	Mfr
8	EA	HW HINGE	5BB1HW 4.5 X 4.5 NRP	630	IVE
2	EA	POWER TRANSFER	EPT10	689	VON
1	EA	ELEC PANIC HARDWARE	RX-QEL+-HH-9847-EO-SNB	630	VON
1	EA	ELEC PANIC HARDWARE	RX-QEL+-HH-9847-NL-OP-110MD- SNB	630	VON
1	EA	RIM CYLINDER	20-057-ICX	626	SCH
1	EA	PRIMUS CORE	20-740-XP EV29 T	626	SCH
2	EA	CUSTOM PULL	PULL BY DOOR MANUFACTURER		
2	EA	SURFACE CLOSER	4040XP RW/PA	689	LCN
2	EA	TOP JAMB MTG PLATE	4040-18TJ	689	LCN
2	EA	FLOOR STOP	FS444	626	IVE
1	EA	THRESHOLD	654A-MSLA-10	A	ZER
1	EA	MULTITECH READER	MTMS15 DIV 28	BLK	SCE
2	EA	DOOR CONTACT	679-05HM DIV 28	BLK	SCE
1	EA	POWER SUPPLY	PS902 900-2RS BY DIV 28	LGR	VON
1			BALANCE OF HARDWARE BY DOOR MANUFACTURER		

WIRING DIAGRAM BY HARDWARE SUPPLIER.
 HURRICANE COMPLIANT OPENING
 DOOR PULLS TO BE THRU-BOLTED.

Hardware Group No. 28 - STOREFRONT NO CARD ACCESS 6'0 X 8'0

Provide each PR door(s) with the following:

Qty		Description	Catalog Number	Finish	Mfr
8	EA	HW HINGE	5BB1HW 4.5 X 4.5 NRP	630	IVE
1	EA	PANIC HARDWARE	HH-9847-EO-SNB	630	VON
1	EA	PANIC HARDWARE	HH-9847-NL-OP-110MD-SNB	630	VON
1	EA	RIM CYLINDER	20-057-ICX	626	SCH
1	EA	PRIMUS CORE	20-740-XP EV29 T	626	SCH
2	EA	CUSTOM PULL	PULL BY DOOR MANUFACTURER		
2	EA	SURFACE CLOSER	4040XP RW/PA	689	LCN
2	EA	TOP JAMB MTG PLATE	4040-18TJ	689	LCN
2	EA	FLOOR STOP	FS444	626	IVE
1	EA	THRESHOLD	654A-MSLA-10	A	ZER

BUILDING STANDARDS – APPENDIX “A” MASTER DOOR HARDWARE
 University of Miami SPECIFICATION 08 70 00

2017 Edition

1 BALANCE OF HARDWARE BY
 DOOR MANUFACTURER

HURRICANE COMPLIANT OPENING
 DOOR PULLS TO BE THRU-BOLTED.

Hardware Group No. 29 - STOREFRONT VESTIBULE

Provide each PR door(s) with the following:

Qty		Description	Catalog Number	Finish	Mfr
8	EA	HW HINGE	5BB1HW 4.5 X 4.5 NRP	630	IVE
2	EA	CUSTOM PULL	PULL BY DOOR MANUFACTURER		
2	EA	SURFACE CLOSER	4040XP RW/PA	689	LCN
2	EA	TOP JAMB MTG PLATE	4040-18TJ	689	LCN
2	EA	FLOOR STOP	FS444	626	IVE
1	EA	THRESHOLD	654A-MSLA-10	A	ZER
1			BALANCE OF HARDWARE BY DOOR MANUFACTURER		

DOOR PULLS TO BE THRU-BOLTED.

Hardware Group No. 30 - CARD ACCESS-STOREFRONT WITH OPERATOR 3'0 X 8'0

Provide each SGL door(s) with the following:

Qty		Description	Catalog Number	Finish	Mfr
4	EA	HW HINGE	5BB1HW 4.5 X 4.5 NRP	630	IVE
1	EA	POWER TRANSFER	EPT10	689	VON
1	EA	ELEC PANIC HARDWARE	RX-QEL+-HH-9847-NL-OP-110MD- SNB	630	VON
1	EA	RIM CYLINDER	20-057-ICX	626	SCH
1	EA	PRIMUS CORE	20-740-XP EV29 T	626	SCH
1	EA	CUSTOM PULL	PULL BY DOOR MANUFACTURER		
1	EA	SURF. AUTO OPERATOR	9542 MS	ANCLR	LCN
2	EA	ACTUATOR, WALL MOUNT	8310-853	630	LCN
1	EA	FLOOR STOP	FS444	626	IVE
1	EA	THRESHOLD	654A-MSLA-10	A	ZER
1	EA	MULTITECH READER	MTMS15 DIV 28	BLK	SCE
1	EA	DOOR CONTACT	679-05HM DIV 28	BLK	SCE

BUILDING STANDARDS – APPENDIX “A” MASTER DOOR HARDWARE
 University of Miami SPECIFICATION 08 70 00

2017 Edition

1	EA	POWER SUPPLY	PS902 900-2RS BY DIV 28	LGR	VON
1			BALANCE OF HARDWARE BY DOOR MANUFACTURER		

WIRING DIAGRAM BY HARDWARE SUPPLIER.
 HURRICANE COMPLIANT OPENING
 DOOR PULLS TO BE THRU-BOLTED.

- 1.) During business hours both outside and inside actuators are active (button pushed and doors open).
- 2.) After hours (time zones end), inside button always active 24/7. However outside button is inactive. Card has to be swiped in order to activate outside button. Once button is pushed door hardware will retract simultaneously with door opening. If button is not pushed after card is swiped door can be pulled open.

Hardware Group No. 31 - ACCESS,CORRIDOR 3'0 X 8'0

Provide each SGL door(s) with the following:

Qty		Description	Catalog Number	Finish	Mfr
4	EA	HINGE	5BB1 4.5 X 4.5	652	IVE
1	EA	ELEC CLASSROOM LOCK	AD-400-CY-70-MS-ATH-PD BY DIV 28	626	SCE
1	EA	PRIMUS K-I-L CYL.	20-750-XP EV29 T	626	SCH
1	EA	SURFACE CLOSER	4040XP EDA	689	LCN
1	EA	KICK PLATE	8400 10" X 2" LDW B-CS	630	IVE
1	EA	WALL STOP	WS407CVX	630	IVE
1	EA	THRESHOLD	PER SILL DETAIL	A	ZER
3	EA	SILENCER	SR64	GRY	IVE

Hardware Group No. 32 - ACCESS,LAB 3'0 X 8'0

Provide each SGL door(s) with the following:

Qty		Description	Catalog Number	Finish	Mfr
4	EA	HINGE	5BB1 4.5 X 4.5	652	IVE
1	EA	ELEC CLASSROOM LOCK	AD-400-CY-70-MS-ATH-PD BY DIV 28	626	SCE
1	EA	PRIMUS K-I-L CYL.	20-750-XP EV29 T	626	SCH
1	EA	SURFACE CLOSER	4040XP RW/PA	689	LCN

BUILDING STANDARDS – APPENDIX “A” MASTER DOOR HARDWARE
 University of Miami SPECIFICATION 08 70 00

2017 Edition

1	EA	KICK PLATE	8400 10" X 2" LDW B-CS	630	IVE
1	EA	WALL STOP	WS407CVX	630	IVE
1	EA	GASKETING	328AA	AA	ZER
1	EA	THRESHOLD	PER SILL DETAIL	A	ZER
3	EA	SILENCER	SR64	GRY	IVE

Hardware Group No. 33 - ACCESS,LAB 3'0 X 8'0

Provide each SGL door(s) with the following:

Qty		Description	Catalog Number	Finish	Mfr
4	EA	HINGE	5BB1 4.5 X 4.5	652	IVE
1	EA	ELEC CLASSROOM LOCK	AD-400-CY-70-MS-ATH-PD BY DIV 28	626	SCE
1	EA	PRIMUS K-I-L CYL.	20-750-XP EV29 T	626	SCH
1	EA	SURFACE CLOSER	4040XP RW/PA	689	LCN
1	EA	KICK PLATE	8400 10" X 2" LDW B-CS	630	IVE
1	EA	WALL STOP	WS407CVX	630	IVE
1	EA	THRESHOLD	PER SILL DETAIL	A	ZER
3	EA	SILENCER	SR64	GRY	IVE

Hardware Group No. 34 - ACCESS,LAB 3'0 X 8'0

Provide each SGL door(s) with the following:

Qty		Description	Catalog Number	Finish	Mfr
4	EA	HINGE	5BB1 4.5 X 4.5	652	IVE
1	EA	ELEC CLASSROOM LOCK	AD-400-CY-70-MS-ATH-PD BY DIV 28	626	SCE
1	EA	PRIMUS K-I-L CYL.	20-750-XP EV29 T	626	SCH
1	EA	OH STOP	450S	630	GLY
1	EA	SURFACE CLOSER	4040XP RW/PA	689	LCN
1	EA	MOUNTING PLATE	4040-18	689	LCN
1	EA	KICK PLATE	8400 10" X 2" LDW B-CS	630	IVE
1	EA	THRESHOLD	PER SILL DETAIL	A	ZER
3	EA	SILENCER	SR64	GRY	IVE

BUILDING STANDARDS – APPENDIX “A” MASTER DOOR HARDWARE
 University of Miami SPECIFICATION 08 70 00

2017 Edition

Hardware Group No. 35 - CARD ACCESS-STOREFRONT, 3'0 X 8'0

Provide each SGL door(s) with the following:

Qty		Description	Catalog Number	Finish	Mfr
4	EA	HW HINGE	5BB1HW 4.5 X 4.5 NRP	630	IVE
1	EA	POWER TRANSFER	EPT10	689	VON
1	EA	ELEC PANIC HARDWARE	RX-QEL+-HH-9847-NL-OP-110MD- SNB	630	VON
1	EA	RIM CYLINDER	20-057-ICX	626	SCH
1	EA	PRIMUS CORE	20-740-XP EV29 T	626	SCH
1	EA	CUSTOM PULL	PULL BY DOOR MANUFACTURER		
1	EA	SURFACE CLOSER	4040XP RW/PA	689	LCN
1	EA	TOP JAMB MTG PLATE	4040-18TJ	689	LCN
1	EA	WALL STOP	WS443	626	IVE
1	EA	THRESHOLD	654A-MSLA-10	A	ZER
1	EA	MULTITECH READER	MTMS15 DIV 28	BLK	SCE
1	EA	DOOR CONTACT	679-05HM DIV 28	BLK	SCE
1	EA	POWER SUPPLY	PS902 900-2RS BY DIV 28	LGR	VON
1			BALANCE OF HARDWARE BY DOOR MANUFACTURER		

WIRING DIAGRAM BY HARDWARE SUPPLIER.
 HURRICANE COMPLIANT OPENING
 DOOR PULLS TO BE THRU-BOLTED.

Hardware Group No. 36 - CARD ACCESS, IN-SWING EXTERIOR MECH 3'0 X 7'0

Provide each SGL door(s) with the following:

Qty		Description	Catalog Number	Finish	Mfr
3	EA	HINGE	5BB1 4.5 X 4.5	652	IVE
1	EA	POWER TRANSFER	EPT10	689	VON
1	EA	EU MORTISE LOCK	L9492JEU 07A	626	SCH
1	EA	PRIMUS CORE	20-740-XP EV29 T	626	SCH
1	EA	SURFACE CLOSER	4040XP RW/PA	689	LCN
1	EA	KICK PLATE	8400 10" X 2" LDW B-CS	630	IVE
1	EA	WALL STOP	WS407CVX	630	IVE
1	EA	GASKETING	328AA	AA	ZER
1	EA	THRESHOLD	65A-MSLA-10	A	ZER
1	EA	RAIN DRIP	11A	A	ZER
1	EA	RAIN DRIP	142A	A	ZER
1	EA	MULTITECH READER	MTMS15 DIV 28	BLK	SCE
1	EA	DOOR CONTACT	679-05HM DIV 28	BLK	SCE

BUILDING STANDARDS – APPENDIX “A” MASTER DOOR HARDWARE
 University of Miami SPECIFICATION 08 70 00

2017 Edition

1 EA POWER SUPPLY PS902 BY DIV 28 LGR VON

HURRICANE COMPLIANT OPENING

Hardware Group No. 37 - SINGLE RESTROOM 3'0 X 8'0

Provide each SGL door(s) with the following:

Qty		Description	Catalog Number	Finish	Mfr
4	EA	HINGE	5BB1 4.5 X 4.5	652	IVE
1	EA	PRIVACY LOCK	ND40S ATH	626	SCH
1	EA	SURFACE CLOSER	4040XP RW/PA	689	LCN
1	EA	KICK PLATE	8400 10" X 2" LDW B-CS	630	IVE
1	EA	MOP PLATE	8400 4" X 1" LDW B-CS	630	IVE
1	EA	WALL STOP	WS407CVX	630	IVE
3	EA	SILENCER	SR64	GRY	IVE

Hardware Group No. 38 - GANG BATHROOM 3'0 X 8'0

Provide each SGL door(s) with the following:

Qty		Description	Catalog Number	Finish	Mfr
4	EA	HINGE	5BB1 4.5 X 4.5	652	IVE
1	EA	CLASSROOM DEADBOLT	B663P	626	SCH
1	EA	DB CYLINDER	22-644 EV29 T	626	SCH
1	EA	PUSH PLATE	8200 8" X 16" CFC	630	IVE
1	EA	PULL PLATE	8305 10" 4" X 16"	630	IVE
1	EA	SURFACE CLOSER	4040XP RW/PA	689	LCN
1	EA	KICK PLATE	8400 10" X 2" LDW B-CS	630	IVE
1	EA	MOP PLATE	8400 6" X 1" LDW B-CS	630	IVE
1	EA	WALL STOP	WS407CVX	630	IVE
3	EA	SILENCER	SR64	GRY	IVE

Hardware Group No. 39 - ACCESS OFFICE NON- RATED, 3'0 X 8'0

Provide each SGL door(s) with the following:

Qty		Description	Catalog Number	Finish	Mfr
4	EA	HINGE	5BB1 4.5 X 4.5	652	IVE

BUILDING STANDARDS – APPENDIX “A” MASTER DOOR HARDWARE
 University of Miami SPECIFICATION 08 70 00

2017 Edition

1	EA	ELEC CLASSROOM LOCK	AD-400-CY-70-MS-ATH-PD BY DIV 28	626	SCE
1	EA	PRIMUS K-I-L CYL.	20-750-XP EV29 T	626	SCH
1	EA	SURFACE CLOSER	4040XP RW/PA	689	LCN
1	EA	KICK PLATE	8400 10" X 2" LDW B-CS	630	IVE
1	EA	WALL STOP	WS407CVX	630	IVE
1	EA	THRESHOLD	PER SILL DETAIL	A	ZER
3	EA	SILENCER	SR64	GRY	IVE

Hardware Group No. 40 - ACCESS OFFICE NON- RATED, 3'0 X 8'0

Provide each SGL door(s) with the following:

Qty		Description	Catalog Number	Finish	Mfr
4	EA	HINGE	5BB1 4.5 X 4.5	652	IVE
1	EA	ELEC CLASSROOM LOCK	AD-400-CY-70-MS-ATH-PD BY DIV 28	626	SCE
1	EA	PRIMUS K-I-L CYL.	20-750-XP EV29 T	626	SCH
1	EA	SURFACE CLOSER	4040XP RW/PA	689	LCN
1	EA	KICK PLATE	8400 10" X 2" LDW B-CS	630	IVE
1	EA	FLOOR STOP	FS436	626	IVE
			/ 438 AS REQUIRED		
1	EA	THRESHOLD	PER SILL DETAIL	A	ZER
3	EA	SILENCER	SR64	GRY	IVE

Hardware Group No. 41 - PUSH/PULL NON FIRE RATED 6'0 X 8'0

Provide each PR door(s) with the following:

Qty		Description	Catalog Number	Finish	Mfr
8	EA	HINGE	5BB1 4.5 X 4.5	652	IVE
2	EA	CUSTOM PUSH/PULL	BY DOOR MANUFACTURER		
2	EA	SURFACE CLOSER	4040XP EDA	689	LCN
2	EA	PA MOUNTING PLATE	4040-18PA	689	LCN
2	EA	FLOOR STOP	FS441	626	IVE
1	EA	THRESHOLD	PER SILL DETAIL	A	ZER
1			BALANCE OF HARDWARE BY DOOR MANUFACTURER		

BUILDING STANDARDS – APPENDIX “A” MASTER DOOR HARDWARE
 University of Miami SPECIFICATION 08 70 00

2017 Edition

Hardware Group No. 42 - ROLL UP DOOR

Provide each RU door(s) with the following:

Qty		Description	Catalog Number	Finish	Mfr
1	EA	MORTISE CYLINDER	20-061-ICX	626	SCH
1	EA	PRIMUS CORE	20-740-XP EV29 T	626	SCH
1		BALANCE OF HARDWARE BY DOOR MANUFACTURER			

Hardware Group No. 43 - ACCESS, HERCULITE DOOR

Provide each PR door(s) with the following:

Qty		Description	Catalog Number	Finish	Mfr
1	EA	MORTISE CYLINDER	20-061-ICX	626	SCH
1	EA	PRIMUS CORE	20-740-XP EV29 T	626	SCH
1	EA	HERC BRACKET	HDB420	630	SCE
1	EA	MAGNETIC LOCK	M420P (BY DIV 28)	628	SCE
2	EA	FLOOR STOP	FS441	626	IVE
1	EA	MULTITECH READER	MTMS15 DIV 28	BLK	SCE
1	EA	PUSHBUTTON	621ALEX DA (BY SEC. 28)	629	SCE
2	EA	DOOR CONTACT	679-05HM DIV 28	BLK	SCE
1	EA	MOTION SENSOR	SCANII DIV 28	WHT	SCE
1	EA	POWER SUPPLY	PS902- FA900 BY DIV 28	LGR	VON
1		BALANCE OF HARDWARE BY DOOR MANUFACTURER			

Hardware Group No. 44 - ALUMINUM

Provide each SGL door(s) with the following:

Qty		Description	Catalog Number	Finish	Mfr
1	EA	MORTISE CYLINDER	20-061-ICX	626	SCH
1	EA	PRIMUS CORE	20-740-XP EV29 T	626	SCH
1	EA	FLOOR STOP	FS441	626	IVE
1		BALANCE OF HARDWARE BY DOOR MANUFACTURER			

HURRICANE COMPLIANT OPENING

BUILDING STANDARDS – APPENDIX “A” MASTER DOOR HARDWARE
 University of Miami SPECIFICATION 08 70 00

2017 Edition

Hardware Group No. 45 - ACCESS EXTERIOR- MECHANICAL, 6'0 X 8'0

Provide each PR door(s) with the following:

Qty		Description	Catalog Number	Finish	Mfr
8	EA	HINGE	5BB1 4.5 X 4.5 NRP	630	IVE
2	EA	SURFACE BOLT	SB360 12" T	604	IVE
1	EA	ELEC CLASSROOM LOCK	AD-400-CY-70-MS-ATH-PD BY DIV 28	626	SCE
1	EA	PRIMUS K-I-L CYL.	20-750-XP EV29 T	626	SCH
2	EA	SURFACE CLOSER	4040XP SCUSH	689	LCN
2	EA	KICK PLATE	8400 10" X 1" LDW B-CS	630	IVE
1	EA	GASKETING	328AA	AA	ZER
2	EA	DOOR BOTTOM	321AA6	AA	ZER
1	EA	THRESHOLD	566A-MSLA-10	A	ZER
1	EA	RAIN DRIP	142A	A	ZER

FLAT ASTRAGAL BY OTHERS
 HURRICANE COMPLIANT OPENING
 ALLOW FOR BOTTOM SURFACE BOLT AND DOOR BOTTOM

Hardware Group No. 46 - ACCESS, UNEQUAL LEAF 6'0 X 8'0

Provide each PR door(s) with the following:

Qty		Description	Catalog Number	Finish	Mfr
8	EA	HINGE	5BB1 4.5 X 4.5	652	IVE
1	EA	MANUAL FLUSH BOLT	FB457	626	IVE
1	EA	MANUAL FLUSH BOLT	FB457 36"	626	IVE
1	EA	DUST PROOF STRIKE	DP2	626	IVE
1	EA	ELEC CLASSROOM LOCK	AD-400-CY-70-MS-ATH-PD-14-049 BY DIV 28	626	SCE
1	EA	PRIMUS K-I-L CYL.	20-750-XP EV29 T	626	SCH
1	EA	SURFACE CLOSER	4040XP RW/PA	689	LCN
2	EA	KICK PLATE	8400 10" X 1" LDW B-CS	630	IVE
2	EA	WALL STOP	WS407CVX	630	IVE
1	EA	THRESHOLD	PER SILL DETAIL	A	ZER
2	EA	SILENCER	SR64	GRY	IVE

CLOSER ON ACTIVE LEAF

BUILDING STANDARDS – APPENDIX “A” MASTER DOOR HARDWARE
 University of Miami SPECIFICATION 08 70 00

2017 Edition

Hardware Group No. 47 - ACCESS, UNEQUAL LEAF 5'0 X 8'0

Provide each PR door(s) with the following:

Qty		Description	Catalog Number	Finish	Mfr
8	EA	HINGE	5BB1 4.5 X 4.5	652	IVE
1	SET	AUTO FLUSH BOLT	FB41P	630	IVE
1	EA	DUST PROOF STRIKE	DP2	626	IVE
1	EA	ELEC CLASSROOM LOCK	AD-400-CY-70-MS-ATH-PD-14-049 BY DIV 28	626	SCE
1	EA	PRIMUS K-I-L CYL.	20-750-XP EV29 T	626	SCH
1	EA	COORDINATOR	COR X FL	628	IVE
1	EA	SURFACE CLOSER	4021 ST-2303	689	LCN
1	EA	SURFACE CLOSER	4040XP RW/PA	689	LCN
1	EA	MOUNTING PLATE	4020-18	689	LCN
2	EA	KICK PLATE	8400 10" X 1" LDW B-CS	630	IVE
2	EA	FLOOR STOP	FS436 / 438 AS REQUIRED	626	IVE
1	EA	GASKETING	328AA	AA	ZER
1	EA	THRESHOLD	PER SILL DETAIL	A	ZER
2	EA	SILENCER	SR64	GRY	IVE

Hardware Group No. 48 - ACCESS, UNEQUAL LEAF 5'0 X 8'0

Provide each PR door(s) with the following:

Qty		Description	Catalog Number	Finish	Mfr
8	EA	HINGE	5BB1 4.5 X 4.5	652	IVE
1	SET	AUTO FLUSH BOLT	FB41P	630	IVE
1	EA	DUST PROOF STRIKE	DP2	626	IVE
1	EA	ELEC PANIC HARDWARE	RX-LC-9875-EO	626	VON
1	EA	ELEC EXIT DEVICE TRIM	AD-400-993R-70-MS-ATH-PD BY DIV 28	626	SCE
1	EA	PRIMUS K-I-L CYL.	20-750-XP EV29 T	626	SCH
1	EA	COORDINATOR	COR X FL	628	IVE
2	EA	MOUNTING BRACKET	MB	689	IVE
1	EA	SURFACE CLOSER	4021 ST-2303	689	LCN
1	EA	SURFACE CLOSER	4040XP RW/PA	689	LCN
1	EA	MOUNTING PLATE	4020-18	689	LCN
2	EA	KICK PLATE	8400 10" X 1" LDW B-CS	630	IVE
2	EA	FLOOR STOP	FS436 / 438 AS REQUIRED	626	IVE
1	EA	GASKETING	328AA	AA	ZER
1	EA	THRESHOLD	PER SILL DETAIL	A	ZER
2	EA	SILENCER	SR64	GRY	IVE

BUILDING STANDARDS – APPENDIX “A” MASTER DOOR HARDWARE
 University of Miami SPECIFICATION 08 70 00

2017 Edition

Hardware Group No. 49 - ACCESS, STORAGE 6'0 X 8'0

Provide each PR door(s) with the following:

Qty		Description	Catalog Number	Finish	Mfr
6	EA	HINGE	5BB1 4.5 X 4.5 NRP	652	IVE
1	EA	MANUAL FLUSH BOLT	FB457	626	IVE
1	EA	MANUAL FLUSH BOLT	FB457 36"	626	IVE
1	EA	DUST PROOF STRIKE	DP2	626	IVE
1	EA	ELEC CLASSROOM LOCK	AD-400-CY-70-MS-ATH-PD-14-049 BY DIV 28	626	SCE
1	EA	PRIMUS K-I-L CYL.	20-750-XP EV29 T	626	SCH
2	EA	SURFACE CLOSER	4040XP EDA	689	LCN
2	EA	KICK PLATE	8400 10" X 1" LDW B-CS	630	IVE
2	EA	WALL STOP	WS407CVX	630	IVE
1	EA	THRESHOLD	PER SILL DETAIL	A	ZER
2	EA	SILENCER	SR64	GRY	IVE

Hardware Group No. 50 - ACCESS-LARGE CLASSROOM RATED 3'0 X 8'0

Provide each SGL door(s) with the following:

Qty		Description	Catalog Number	Finish	Mfr
4	EA	HINGE	5BB1 4.5 X 4.5	652	IVE
1	EA	ELEC FIRE EXIT HARDWARE	RX-LC-98-EO-F-SNB	626	VON
1	EA	ELEC EXIT DEVICE TRIM	AD-400-993R-70-MS-ATH-PD BY DIV 28	626	SCE
1	EA	PRIMUS K-I-L CYL.	20-750-XP EV29 T	626	SCH
1	EA	SURFACE CLOSER	4040XP EDA	689	LCN
1	EA	KICK PLATE	8400 10" X 2" LDW B-CS	630	IVE
1	EA	WALL STOP	WS407CVX	630	IVE
1	EA	GASKETING	328AA	AA	ZER
1	EA	THRESHOLD	PER SILL DETAIL	A	ZER
3	EA	SILENCER	SR64	GRY	IVE

BUILDING STANDARDS – APPENDIX “A” MASTER DOOR HARDWARE
 University of Miami SPECIFICATION 08 70 00

2017 Edition

Hardware Group No. 51 - ACCESS-LARGE CLASSROOM, STAIR RATED 3'0 X 8'0

Provide each SGL door(s) with the following:

Qty		Description	Catalog Number	Finish	Mfr
4	EA	HINGE	5BB1 4.5 X 4.5	652	IVE
1	EA	ELEC FIRE EXIT HARDWARE	RX-LC-98-EO-F-SNB	626	VON
1	EA	ELEC EXIT DEVICE TRIM	AD-400-993R-70-MS-ATH-PD BY DIV 28	626	SCE
1	EA	PRIMUS K-I-L CYL.	20-750-XP EV29 T	626	SCH
1	EA	SURFACE CLOSER	4040XP SCUSH	689	LCN
1	EA	KICK PLATE	8400 10" X 2" LDW B-CS	630	IVE
1	EA	GASKETING	328AA	AA	ZER
1	EA	THRESHOLD	PER SILL DETAIL	A	ZER
3	EA	SILENCER	SR64	GRY	IVE

Hardware Group No. 52 - ACCESS, INTERIOR UNEQUAL LEAF NON-RATED 6'0 X 8'0

Provide each PR door(s) with the following:

Qty		Description	Catalog Number	Finish	Mfr
8	EA	HINGE	5BB1 4.5 X 4.5 NRP	652	IVE
1	EA	MANUAL FLUSH BOLT	FB457	626	IVE
1	EA	MANUAL FLUSH BOLT	FB457 36"	626	IVE
1	EA	DUST PROOF STRIKE	DP2	626	IVE
1	EA	ELEC CLASSROOM LOCK	AD-400-CY-70-MS-ATH-PD BY DIV 28	626	SCE
1	EA	PRIMUS K-I-L CYL.	20-750-XP EV29 T	626	SCH
2	EA	SURFACE CLOSER	4040XP RW/PA	689	LCN
2	EA	KICK PLATE	8400 10" X 1" LDW B-CS	630	IVE
2	EA	WALL STOP	WS407CVX	630	IVE
1	EA	THRESHOLD	PER SILL DETAIL	A	ZER
2	EA	SILENCER	SR64	GRY	IVE

Z ASTRAGAL BY DOOR SUPPLIER

BUILDING STANDARDS – APPENDIX “A” MASTER DOOR HARDWARE
 University of Miami SPECIFICATION 08 70 00

2017 Edition

Hardware Group No. 53 - EXTERIOR ROOF, LOCKED BOTH SIDES, 3'0 X 8'0

Provide each SGL door(s) with the following:

Qty		Description	Catalog Number	Finish	Mfr
3	EA	HW HINGE	5BB1HW 4.5 X 4.5 NRP	630	IVE
1	EA	DBL CYL STORE LOCK	ND66PD ATH	626	SCH
2	EA	PRIMUS K-I-L CYL.	20-765-XP EV29 T	626	SCH
1	EA	SURFACE CLOSER	4040XP SCUSH	689	LCN
1	EA	KICK PLATE	8400 10" X 2" LDW B-CS	630	IVE
1	EA	GASKETING	328AA	AA	ZER
1	EA	THRESHOLD	65A-MSLA-10	A	ZER
1	EA	RAIN DRIP	142A	A	ZER

Hardware Group No. 54

Provide each RU door(s) with the following:

Qty		Description	Catalog Number	Finish	Mfr
1			HARDWARE BY DOOR MANUFACTURER		

Hardware Group No. 55 - ACCESS EXTERIOR- ROOF, NON- RATED, 3'0 X 7'0

Provide each SGL door(s) with the following:

Qty		Description	Catalog Number	Finish	Mfr
3	EA	HINGE	5BB1 4.5 X 4.5 NRP	630	IVE
1	EA	ELEC CLASSROOM LOCK	AD-400-CY-70-MS-ATH-PD BY DIV 28	626	SCE
1	EA	PRIMUS K-I-L CYL.	20-750-XP EV29 T	626	SCH
1	EA	SURFACE CLOSER	4040XP SCUSH	689	LCN
1	EA	GASKETING	328AA	AA	ZER
1	EA	DOOR BOTTOM	321AA6	AA	ZER
1	EA	THRESHOLD	566A-MSLA-10	A	ZER
1	EA	RAIN DRIP	142A	A	ZER

HURRICANE COMPLIANT OPENING

BUILDING STANDARDS – APPENDIX “A” MASTER DOOR HARDWARE
 University of Miami SPECIFICATION 08 70 00

2017 Edition

Hardware Group No. 56 - ACCESS EXTERIOR- ROOF, NON- RATED, 3'0 X 8'0

Provide each SGL door(s) with the following:

Qty		Description	Catalog Number	Finish	Mfr
4	EA	HINGE	5BB1 4.5 X 4.5 NRP	630	IVE
1	EA	ELEC CLASSROOM LOCK	AD-400-CY-70-MS-ATH-PD BY DIV 28	626	SCE
1	EA	PRIMUS K-I-L CYL.	20-750-XP EV29 T	626	SCH
1	EA	SURFACE CLOSER	4040XP SCUSH	689	LCN
1	EA	GASKETING	328AA	AA	ZER
1	EA	DOOR BOTTOM	321AA6	AA	ZER
1	EA	THRESHOLD	566A-MSLA-10	A	ZER
1	EA	RAIN DRIP	142A	A	ZER

HURRICANE COMPLIANT OPENING

Hardware Group No. 57 - INTERIOR- “NDE” NON RATED WITH SMART CARD READER 3'0 X 7'0

Provide each SGL door(s) with the following:

Qty		Description	Catalog Number	Finish	Mfr
3	EA	HINGE	5BB1 4.5 X 4.5	652	IVE
1	EA	WIRELESS ELECTRONIC LOCK	NDE80PD ATH	626	SCH
1	EA	PRIMUS K-I-L CYL.	20-765-XP EV29 T	626	SCH
1	EA	SURFACE CLOSER	4040XP RW/PA	689	LCN
1	EA	KICK PLATE	8400 10" X 2" LDW B-CS	630	IVE
1	EA	WALL STOP	WS407CVX	630	IVE
3	EA	SILENCER	SR64	GRY	IVE

Hardware Group No. 58 - INTERIOR- “NDE” RATED WITH SMART CARD READER 3'0 X 7'0

Provide each SGL door(s) with the following:

Qty		Description	Catalog Number	Finish	Mfr
3	EA	HINGE	5BB1 4.5 X 4.5	652	IVE
1	EA	WIRELESS ELECTRONIC LOCK	NDE80PD ATH	626	SCH
1	EA	PRIMUS K-I-L CYL.	20-765-XP EV29 T	626	SCH
1	EA	SURFACE CLOSER	4040XP RW/PA	689	LCN
1	EA	KICK PLATE	8400 10" X 2" LDW B-CS	630	IVE
1	EA	WALL STOP	WS407CVX	630	IVE
1	EA	GASKETING	188S-BK	S-Bk	ZER

BUILDING STANDARDS – APPENDIX “A” MASTER DOOR HARDWARE
 University of Miami SPECIFICATION 08 70 00

2017 Edition

Hardware Group No. 59 - INTERIOR- “NDE” NON RATED WITH SMART CARD READER 3’0 X 8’0

Provide each SGL door(s) with the following:

Qty		Description	Catalog Number	Finish	Mfr
4	EA	HINGE	5BB1 4.5 X 4.5	652	IVE
1	EA	WIRELESS ELECTRONIC LOCK	NDE80PD ATH	626	SCH
1	EA	PRIMUS K-I-L CYL.	20-765-XP EV29 T	626	SCH
1	EA	SURFACE CLOSER	4040XP RW/PA	689	LCN
1	EA	KICK PLATE	8400 10" X 2" LDW B-CS	630	IVE
1	EA	WALL STOP	WS407CVX	630	IVE
3	EA	SILENCER	SR64	GRY	IVE

Hardware Group No. 60 - INTERIOR- “NDE” RATED WITH SMART CARD READER 3’0 X 8’0

Provide each SGL door(s) with the following:

Qty		Description	Catalog Number	Finish	Mfr
4	EA	HINGE	5BB1 4.5 X 4.5	652	IVE
1	EA	WIRELESS ELECTRONIC LOCK	NDE80PD ATH	626	SCH
1	EA	PRIMUS K-I-L CYL.	20-765-XP EV29 T	626	SCH
1	EA	SURFACE CLOSER	4040XP RW/PA	689	LCN
1	EA	KICK PLATE	8400 10" X 2" LDW B-CS	630	IVE
1	EA	WALL STOP	WS407CVX	630	IVE
1	EA	GASKETING	188S-BK	S-Bk	ZER

Hardware Group No. 61 - ACCESS WITH PANIC NON- RATED, 3’0 X 8’0

Provide each SGL door(s) with the following:

Qty		Description	Catalog Number	Finish	Mfr
4	EA	HINGE	5BB1 4.5 X 4.5	652	IVE
1	EA	PANIC HARDWARE	98-L-NL-07	626	VON
1	EA	RIM CYLINDER	20-057-ICX	626	SCH
1	EA	PRIMUS CORE	20-740-XP EV29 T	626	SCH
1	EA	ELECTRIC STRIKE	6300 FSE DIV 28	630	VON
1	EA	SURFACE CLOSER	4040XP RW/PA	689	LCN
1	EA	KICK PLATE	8400 10" X 2" LDW B-CS	630	IVE
1	EA	WALL STOP	WS407CVX	630	IVE
3	EA	SILENCER	SR64	GRY	IVE
1	EA	MULTITECH READER	MTMS15 DIV 28	BLK	SCE
1	EA	DOOR CONTACT	679-05HM DIV 28	BLK	SCE
1	EA	MOTION SENSOR	SCANII DIV 28	WHT	SCE

BUILDING STANDARDS – APPENDIX “A” MASTER DOOR HARDWARE
 University of Miami SPECIFICATION 08 70 00

2017 Edition

Hardware Group No. 62 - ACCESS WITH LOCKSET OFFICE NON- RATED, 3'0 X 8'0

Provide each SGL door(s) with the following:

Qty		Description	Catalog Number	Finish	Mfr
4	EA	HINGE	5BB1 4.5 X 4.5	652	IVE
1	EA	STOREROOM LOCK	ND96PD ATH	626	SCH
1	EA	PRIMUS K-I-L CYL.	20-765-XP EV29 T	626	SCH
1	EA	ELECTRIC STRIKE	6211 FSE DIV 28	630	VON
1	EA	SURFACE CLOSER	4040XP RW/PA	689	LCN
1	EA	KICK PLATE	8400 10" X 2" LDW B-CS	630	IVE
1	EA	WALL STOP	WS407CVX	630	IVE
3	EA	SILENCER	SR64	GRY	IVE
1	EA	MULTITECH READER	MTMS15 DIV 28	BLK	SCE
1	EA	DOOR CONTACT	679-05HM DIV 28	BLK	SCE
1	EA	MOTION SENSOR	SCANII DIV 28	WHT	SCE

Hardware Group No. 63 - ENTRY DOOR HOUSING "University Village"

Provide each SGL door(s) with the following:

Qty		Description	Catalog Number	Finish	Mfr
3	EA	HINGE	5BB1 4.5 X 4.5 NRP	630	IVE
1	EA	ELEC CLASSROOM LOCK	AD-400-CY-70-MS-ATH-PD BY DIV 28	626	SCE
1	EA	PRIMUS K-I-L CYL.	20-750-XP EV29 T	626	SCH
1	EA	SURFACE CLOSER	4040XP SCUSH	689	LCN
1	EA	WALL STOP	WS407CVX	630	IVE
1	EA	GASKETING	328AA	AA	ZER
1	EA	DOOR BOTTOM	367AA6	AA	ZER
1	EA	THRESHOLD	PER SILL DETAIL	A	ZER
1	EA	DOOR VIEWER	U698	626	IVE

Hardware Group No. 64 - INTERIOR ENTRY DOOR "HOUSING"

Provide each SGL door(s) with the following:

Qty		Description	Catalog Number	Finish	Mfr
3	EA	HINGE	5BB1 4.5 X 4.5	652	IVE
1	EA	ELEC CLASSROOM LOCK	AD-400-CY-70-MS-ATH-PD BY DIV 28	626	SCE
1	EA	PRIMUS K-I-L CYL.	20-750-XP EV29 T	626	SCH
1	EA	SURFACE CLOSER	4040XP H	689	LCN
1	EA	WALL STOP	WS407CVX	630	IVE
3	EA	SILENCER	SR64	GRY	IVE
1	EA	DOOR VIEWER	U698	626	IVE

BUILDING STANDARDS – APPENDIX “A” MASTER DOOR HARDWARE
 University of Miami SPECIFICATION 08 70 00

2017 Edition

Hardware Group No. 65 - INTERIOR BEDROOM DOOR "HOUSING"

Provide each SGL door(s) with the following:

Qty		Description	Catalog Number	Finish	Mfr
3	EA	HINGE	5BB1 4.5 X 4.5	652	IVE
1	EA	ELEC CLASSROOM LOCK	AD-400-CY-70-MS-ATH-PD BY DIV 28	626	SCE
1	EA	PRIMUS K-I-L CYL.	20-750-XP EV29 T	626	SCH
1	EA	WALL STOP	WS407CVX	630	IVE
3	EA	SILENCER	SR64	GRY	IVE

Hardware Group No. 66 - INTERIOR RESTROOM DOOR "HOUSING"

Provide each SGL door(s) with the following:

Qty		Description	Catalog Number	Finish	Mfr
3	EA	HINGE	5BB1 4.5 X 4.5	652	IVE
1	EA	PRIVACY LOCK	ND40S ATH	626	SCH
1	EA	WALL STOP	WS407CVX	630	IVE
3	EA	SILENCER	SR64	GRY	IVE

APPENDIX B: ELECTRONIC DOOR / CARD ACCESS DIAGRAMS

KEYED NOTES:

- ② CONCEALED 4" X 4" COVERED JUNCTION BOX LOCATED NEAR DOOR ABOVE CEILING ACCESSIBLE TO SECURE SIDE. (BY DIV 26)
- ③ CONCEALED DOOR POSITION SENSOR PROVIDE $\frac{3}{4}$ " CONDUIT AND REQUIRED FRAME AND PATHWAY PREPARATION (BY DIV 26)
- ④ CONCEALED 1" DOOR POSITION SENSOR 679-05HM (DIV 28)
- ⑤ ALLEGION POWER TRANSFER EPT-10 (BY DIV 08)
- ⑥ PROVIDE $\frac{3}{4}$ " CONDUIT, REQUIRED FRAME AND PATHWAY PREPARATION FOR WIREWAY THROUGH DOOR (BY DIV 26)
- ⑦ AD-400-993R-70-MS-ATH-PD (BY DIV 28)
- ⑧ EXIT DEVICE RX-LC-HH-98-EO-SNB (BY DIV 8)
- ⑨ KEYED FIRE RATED REMOVABLE MULLION (BY DIV 8)

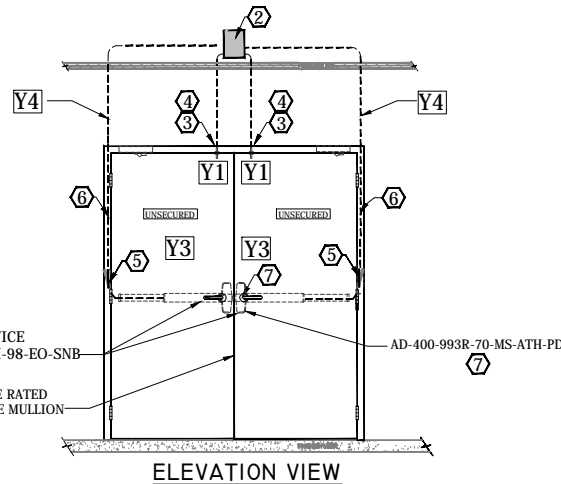
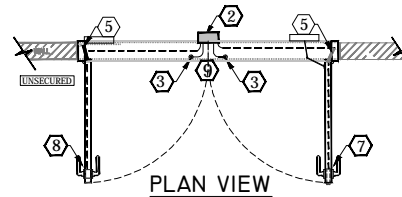

HW-1 Hardware Group No. 01
Not to Scale

HARDWARE GROUPS BASED ON
UMBS 087100 DOOR HARDWARE
STANDARDS 2017 EDITION

GENERAL NOTES CABLE SCHEDULE		
DESIGNATION	DEVICE	CABLE CONFIGURATION
Y1	DPS	4-COND. 22 AWG NO SHIELD
Y2	CR	8-COND. 18 AWG SHIELDED W/DRAIN
Y3	RX	6-COND. 18 AWG SHIELDED NO SHIELD
Y4	EL	4-COND. 18 AWG SHIELDED NO SHIELD
Y	CR-DPS- RX-EL	COMPOSITE CABLE
P	PIM	2-CONDUCTOR 18 AWG 1 PAIR 22 AWG Shielded
P	AD-300	2-CONDUCTOR 18 AWG 1 PAIR 22 AWG Shielded
P	NDE	2-CONDUCTOR 18 AWG 1 PAIR 22 AWG Shielded
AD-WL	AD-400	WIRELESS LOCK
COMPONENT LEGEND		
CR	CARD READER	
DPS	DOOR POSITION SWITCH	
RX	REQUEST TO EXIT	
LX	LATCH BOLT MONITOR	
EL	ELECTRIC EXIT DEVICE	
ES	ELECTRIC STRIKE	
PT	ELECTRIC PASS THROUGH DEVICE	
PIM	PIM-16-485	
AD-400	AD-400 WIRELESS LOCK	
AD-300	AD-300 HARDWIRED LOCK	
NDE	NDE WIRELESS LOCK	
ES	ELECTRIC HARDWARE POWER SUPPLY	
ADA	HANDICAP OPERATOR (TYPICAL)	
PP	HANDICAP PUSH PLATE (TYPICAL)	
CABLE DESCRIPTION		
Y- WCW COMPOSITE CABLE SPECIFY RISER OR PLENUM WCW Composite Cable PN# Chord-AC-A-PL		
NON-EXTENDED CABLE		
Y-1	4-Cond. #22 AWG/STRD/NO SHIELD	WCW#444381-PL
Y-2	8-Cond. #18 AWG/STRD/SHLD W/DRAIN	WCW#002352-PL
Y-3	6-Cond. #18 AWG/STRD/NO SHIELD	WCW#U002391-04-PL
Y-4	4-Cond. #18 AWG/STRD/NO SHIELD	WCW#442380-PL
P	2-COND. #18 AWG 1 PAIR 22 AWG Shielded	WCW-92ELEMPLNTY
X- WCW COMPOSITE CABLE SPECIFY RISER OR PLENUM WCW Composite Cable PN# Chord-AC-A-EXT-PL		
EXTENDED CABLE		
X-1	4-Cond. #22 AWG/STRD/NO SHIELD	WCW#444381-PL
X-2	8-Cond. #18 AWG/STRD/SHLD W/DRAIN	WCW #002352-PL
X-3	6-Cond. #18 AWG/STRD/NO SHIELD	WCW#U002391-04-PL
X-4	4-Cond. #16 AWG/STRD/NO SHIELD	WCW#991380-PL
P	2-COND. #18 AWG 1 PAIR 22 AWG Shielded	WCW-92ELEMPLNTY

Project Name and Address
Univ of Miami
Device Elevation
SHOP DWG: DD-1

KEYED NOTES:

- ① CONCEALED DOOR POSITION SENSOR INCLUDED IN AD-400 KIT
- ② AD-400-CY-70-MS-8AT ATH-PD (BY DIV 28)
- ③ SURFACE BOLT (BY DIV 8)

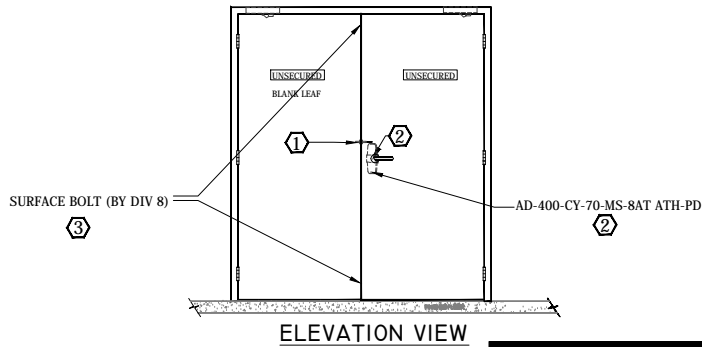
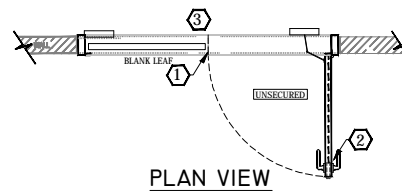

HW-2 Hardware Group No. 02
Not to Scale

HARDWARE GROUPS BASED ON
UMBS 087100 DOOR HARDWARE
STANDARDS 2017 EDITION

GENERAL NOTES
CABLE SCHEDULE

DESIGNATION	DEVICE	CABLE CONFIGURATION
Y1	DPS	4-COND. 22 AWG NO SHIELD
Y2	CR	8-COND. 18 AWG SHIELDED W/DRAIN
Y3	RX	6-COND. 18 AWG SHIELDED NO SHIELD
Y4	EL	4-COND. 18 AWG SHIELDED NO SHIELD
Y	CR-DPS- RX-EL	COMPOSITE CABLE
P	PIM	2-CONDUCTOR 18 AWG 1 PAIR 22 AWG Shielded
P	AD-300	2-CONDUCTOR 18 AWG 1 PAIR 22 AWG Shielded
P	NDE	2-CONDUCTOR 18 AWG 1 PAIR 22 AWG Shielded
AD-WL	AD-400	WIRELESS LOCK

COMPONENT LEGEND

CR	CARD READER
DPS	DOOR POSITION SWITCH
RX	REQUEST TO EXIT
LX	LATCH BOLT MONITOR
EL	ELECTRIC EXIT DEVICE
ES	ELECTRIC STRIKE
PT	ELECTRIC PASS THROUGH DEVICE
PIM	PIM-16-485
AD-400	AD-400 WIRELESS LOCK
AD-300	AD-300 HARDWIRED LOCK
NDE	NDE WIRELESS LOCK
ES	ELECTRIC HARDWARE POWER SUPPLY
ADA	HANDICAP OPERATOR (TYPICAL)
PP	HANDICAP PUSH PLATE (TYPICAL)

CABLE DESCRIPTION

Y- WCW COMPOSITE CABLE SPECIFY RISER OR PLENUM WCW Composite Cable PN# Chord-AC-A-PL		
NON-EXTENDED CABLE		
Y-1	4-Cond. #22 AWG/STRD/NO SHIELD	WCW#444381-PL
Y-2	8-Cond. #18 AWG/STRD/SHLD W/DRAIN	WCW#002352-PL
Y-3	6-Cond. #18 AWG/STRD/NO SHIELD	WCW#U002391-04-PL
Y-4	4-Cond. #18 AWG/STRD/NO SHIELD	WCW#442380-PL
P	2-COND. #18 AWG 1 PAIR 22 AWG Shielded	WCW-92ELEMPLNTY
X- WCW COMPOSITE CABLE SPECIFY RISER OR PLENUM WCW Composite Cable PN# Chord-AC-A-EXT-PL		
EXTENDED CABLE		
X-1	4-Cond. #22 AWG/STRD/NO SHIELD	WCW#444381-PL
X-2	8-Cond. #18 AWG/STRD/SHLD W/DRAIN	WCW#002352-PL
X-3	6-Cond. #18 AWG/STRD/NO SHIELD	WCW#U002391-04-PL
X-4	4-Cond. #16 AWG/STRD/NO SHIELD	WCW#991380-PL
P	2-COND. #18 AWG 1 PAIR 22 AWG Shielded	WCW-92ELEMPLNTY

Project Name and Address

Univ of Miami
Device Elevation
SHOP DWG: DD-2

KEYED NOTES:

- ① CONCEALED DOOR POSITION SENSOR INCLUDED IN AD-400 KIT
- ② AD-400-993R-70-MS-ATH-PD (BY DIV 28)
- ③ EXIT DEVICE RX-LC-HH-98-EO-F-SNB ELEC HARDWARE FIRE EXIT DEVICE

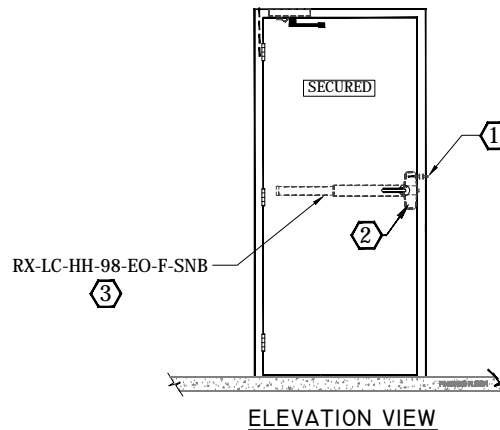
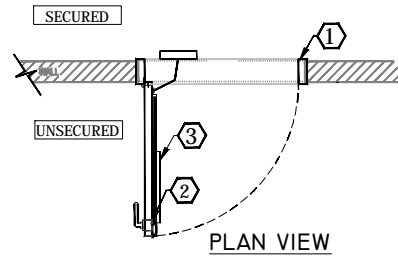

HW-3 Hardware Group No. 03
Not to Scale

HARDWARE GROUPS BASED ON
UMBS 087100 DOOR HARDWARE
STANDARDS 2017 EDITION

GENERAL NOTES
CABLE SCHEDULE

DESIGNATION	DEVICE	CABLE CONFIGURATION
Y1	DPS	4-COND. 22 AWG NO SHIELD
Y2	CR	8-COND. 18 AWG SHIELDED W/DRAIN
Y3	RX	6-COND. 18 AWG SHIELDED NO SHIELD
Y4	EL	4-COND. 18 AWG SHIELDED NO SHIELD
Y	CR-DPS- RX-EL	COMPOSITE CABLE
P	PIM	2-CONDUCTOR 18 AWG 1 PAIR 22 AWG Shielded
P	AD-300	2-CONDUCTOR 18 AWG 1 PAIR 22 AWG Shielded
P	NDE	2-CONDUCTOR 18 AWG 1 PAIR 22 AWG Shielded
AD-WL	AD-400	WIRELESS LOCK

COMPONENT LEGEND

CR	CARD READER
DPS	DOOR POSITION SWITCH
RX	REQUEST TO EXIT
LX	LATCH BOLT MONITOR
EL	ELECTRIC EXIT DEVICE
ES	ELECTRIC STRIKE
PT	ELECTRIC PASS THROUGH DEVICE
PIM	PIM-16-485
AD-400	AD-400 WIRELESS LOCK
AD-300	AD-300 HARDWIRED LOCK
NDE	NDE WIRELESS LOCK
ES	ELECTRIC HARDWARE POWER SUPPLY
ADA	HANDICAP OPERATOR (TYPICAL)
PP	HANDICAP PUSH PLATE (TYPICAL)

CABLE DESCRIPTION

Y- WCW COMPOSITE CABLE SPECIFY RISER OR PLENUM WCW Composite Cable PN# Chord-AC-A-PL NON-EXTENDED CABLE	
Y-1	4-Cond. #22 AWG/STRD/NO SHIELD WCW#444381-PL
Y-2	8-Cond. #18 AWG/STRD/SHLD W/DRAIN WCW#002352-PL
Y-3	6-Cond. #18 AWG/STRD/NO SHIELD WCW#UD02391-04-PL
Y-4	4-Cond. #18 AWG/STRD/NO SHIELD WCW#442380-PL
P	2-COND. #18 AWG 1 PAIR 22 AWG Shielded WCW-92ELEMPNTY
X- WCW COMPOSITE CABLE SPECIFY RISER OR PLENUM WCW Composite Cable PN# Chord-AC-A-EXT-PL EXTENDED CABLE	
X-1	4-Cond. #22 AWG/STRD/NO SHIELD WCW#444381-PL
X-2	8-Cond. #18 AWG/STRD/SHLD W/DRAIN WCW#002352-PL
X-3	6-Cond. #18 AWG/STRD/NO SHIELD WCW#UD02391-04-PL
X-4	4-Cond. #16 AWG/STRD/NO SHIELD WCW#991380-PL
P	2-COND. #18 AWG 1 PAIR 22 AWG Shielded WCW-92ELEMPNTY

Project Name and Address

Univ of Miami
Device Elevation
SHOP DWG: SD-1

KEYED NOTES:

- ① CONCEALED DOOR POSITION SENSOR INCLUDED IN AD-400 KIT
- ② AD-400-CY-70-MS-ATH-PD (BY DIV 28)

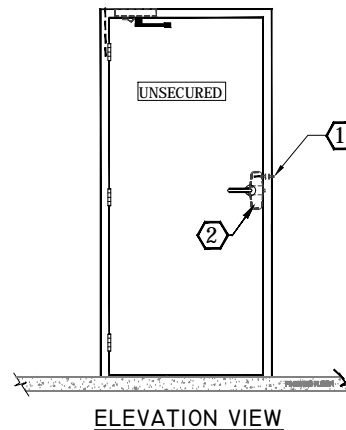
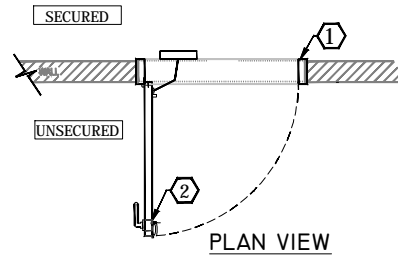

HW-4 Hardware Group No. 04
Not to Scale

HARDWARE GROUPS BASED ON
UMBS 087100 DOOR HARDWARE
STANDARDS 2017 EDITION

GENERAL NOTES
CABLE SCHEDULE

DESIGNATION	DEVICE	CABLE CONFIGURATION
Y1	DPS	4-COND. 22 AWG NO SHIELD
Y2	CR	8-COND. 18 AWG SHIELDED W/DRAIN
Y3	RX	6-COND. 18 AWG SHIELDED NO SHIELD
Y4	EL	4-COND. 18 AWG SHIELDED NO SHIELD
Y	CR-DPS- RX-EL	COMPOSITE CABLE
P	PIM	2-CONDUCTOR 18 AWG 1 PAIR 22 AWG Shielded
P	AD-300	2-CONDUCTOR 18 AWG 1 PAIR 22 AWG Shielded
P	NDE	2-CONDUCTOR 18 AWG 1 PAIR 22 AWG Shielded
AD-WL	AD-400	WIRELESS LOCK

COMPONENT LEGEND

CR	CARD READER
DPS	DOOR POSITION SWITCH
RX	REQUEST TO EXIT
LX	LATCH BOLT MONITOR
EL	ELECTRIC EXIT DEVICE
ES	ELECTRIC STRIKE
PT	ELECTRIC PASS THROUGH DEVICE
PIM	PIM-16-485
AD-400	AD-400 WIRELESS LOCK
AD-300	AD-300 HARDWIRED LOCK
NDE	NDE WIRELESS LOCK
ES	ELECTRIC HARDWARE POWER SUPPLY
ADA	HANDICAP OPERATOR (TYPICAL)
PP	HANDICAP PUSH PLATE (TYPICAL)

CABLE DESCRIPTION

Y- WCW COMPOSITE CABLE SPECIFY RISER OR PLENUM WCW Composite Cable PN# Chord-AC-A-PL	
NON-EXTENDED CABLE	
Y-1	4-Cond. #22 AWG/STRD/NO SHIELD WCW#444381-PL
Y-2	8-Cond. #18 AWG/STRD/SHLD W/DRAIN WCW#002352-PL
Y-3	6-Cond. #18 AWG/STRD/NO SHIELD WCW#U002391-04-PL
Y-4	4-Cond. #18 AWG/STRD/NO SHIELD WCW#442380-PL
P	2-COND. #18 AWG 1 PAIR 22 AWG Shielded WCW-92ELEMPLNTY
X- WCW COMPOSITE CABLE SPECIFY RISER OR PLENUM WCW Composite Cable PN# Chord-AC-A-EXT-PL	
EXTENDED CABLE	
X-1	4-Cond. #22 AWG/STRD/NO SHIELD WCW#444381-PL
X-2	8-Cond. #18 AWG/STRD/SHLD W/DRAIN WCW #002352-PL
X-3	6-Cond. #18 AWG/STRD/NO SHIELD WCW#U002391-04-PL
X-4	4-Cond. #16 AWG/STRD/NO SHIELD WCW#991380-PL
P	2-COND. #18 AWG 1 PAIR 22 AWG Shielded WCW-92ELEMPLNTY

Project Name and Address

Univ of Miami
Device Elevation
SHOP DWG: SD-2

KEYED NOTES:

- ① CONCEALED DOOR POSITION SENSOR INCLUDED IN AD-400 KIT
- ② AD-400-CY-70-MS-ATH-PD (BY DIV 28)

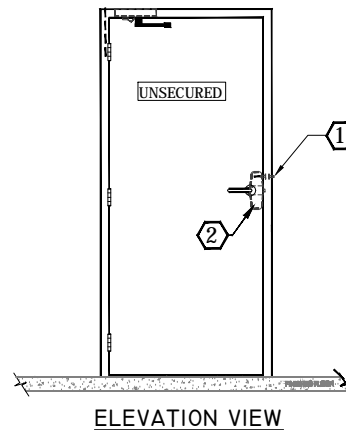
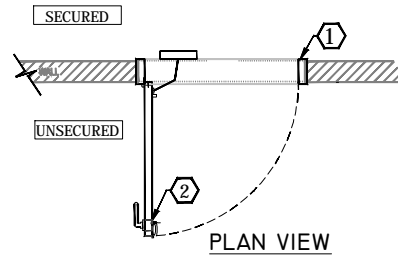

HW-5 Hardware Group No. 05
Not to Scale

HARDWARE GROUPS BASED ON
UMBS 087100 DOOR HARDWARE
STANDARDS 2017 EDITION

GENERAL NOTES
CABLE SCHEDULE

DESIGNATION	DEVICE	CABLE CONFIGURATION
Y1	DPS	4-COND. 22 AWG NO SHIELD
Y2	CR	8-COND. 18 AWG SHIELDED W/DRAIN
Y3	RX	6-COND. 18 AWG SHIELDED NO SHIELD
Y4	EL	4-COND. 18 AWG SHIELDED NO SHIELD
Y	CR-DPS- RX-EL	COMPOSITE CABLE
P	PIM	2-CONDUCTOR 18 AWG 1 PAIR 22 AWG Shielded
P	AD-300	2-CONDUCTOR 18 AWG 1 PAIR 22 AWG Shielded
P	NDE	2-CONDUCTOR 18 AWG 1 PAIR 22 AWG Shielded
AD-WL	AD-400	WIRELESS LOCK

COMPONENT LEGEND

CR	CARD READER
DPS	DOOR POSITION SWITCH
RX	REQUEST TO EXIT
LX	LATCH BOLT MONITOR
EL	ELECTRIC EXIT DEVICE
ES	ELECTRIC STRIKE
PT	ELECTRIC PASS THROUGH DEVICE
PIM	PIM-16-485
AD-400	AD-400 WIRELESS LOCK
AD-300	AD-300 HARDWIRED LOCK
NDE	NDE WIRELESS LOCK
ES	ELECTRIC HARDWARE POWER SUPPLY
ADA	HANDICAP OPERATOR (TYPICAL)
PP	HANDICAP PUSH PLATE (TYPICAL)

CABLE DESCRIPTION

Y- WCW COMPOSITE CABLE SPECIFY RISER OR PLENUM WCW Composite Cable PN# Chord-AC-A-PL	
NON-EXTENDED CABLE	
Y-1	4-Cond. #22 AWG/STRD/NO SHIELD WCW#444381-PL
Y-2	8-Cond. #18 AWG/STRD/SHLD W/DRAIN WCW#002352-PL
Y-3	6-Cond. #18 AWG/STRD/NO SHIELD WCW#U002391-04-PL
Y-4	4-Cond. #18 AWG/STRD/NO SHIELD WCW#442380-PL
P	2-COND. #18 AWG 1 PAIR 22 AWG Shielded WCW-92ELEMPLNTY
X- WCW COMPOSITE CABLE SPECIFY RISER OR PLENUM WCW Composite Cable PN# Chord-AC-A-EXT-PL	
EXTENDED CABLE	
X-1	4-Cond. #22 AWG/STRD/NO SHIELD WCW#444381-PL
X-2	8-Cond. #18 AWG/STRD/SHLD W/DRAIN WCW #002352-PL
X-3	6-Cond. #18 AWG/STRD/NO SHIELD WCW#U002391-04-PL
X-4	4-Cond. #16 AWG/STRD/NO SHIELD WCW#991380-PL
P	2-COND. #18 AWG 1 PAIR 22 AWG Shielded WCW-92ELEMPLNTY

Project Name and Address

Univ of Miami
Device Elevation
SHOP DWG: SD-3

KEYED NOTES:

- ① CONCEALED DOOR POSITION SENSOR INCLUDED IN AD-400 KIT
- ② AD-400-CY-70-MS-ATH-PD (BY DIV 28)

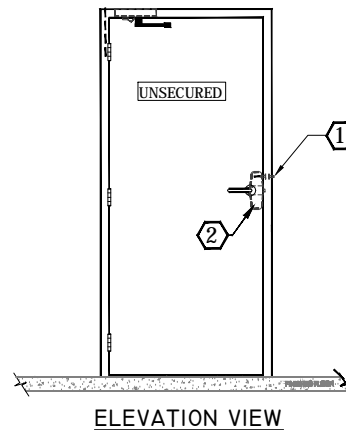
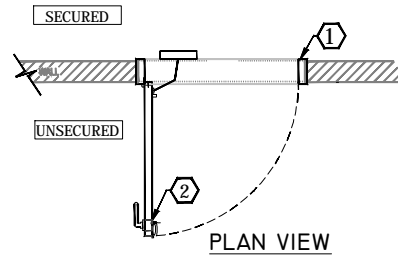

HW-6 Hardware Group No. 06
Not to Scale

HARDWARE GROUPS BASED ON
UMBS 087100 DOOR HARDWARE
STANDARDS 2017 EDITION

GENERAL NOTES
CABLE SCHEDULE

DESIGNATION	DEVICE	CABLE CONFIGURATION
Y1	DPS	4-COND. 22 AWG NO SHIELD
Y2	CR	8-COND. 18 AWG SHIELDED W/DRAIN
Y3	RX	6-COND. 18 AWG SHIELDED NO SHIELD
Y4	EL	4-COND. 18 AWG SHIELDED NO SHIELD
Y	CR-DPS- RX-EL	COMPOSITE CABLE
P	PIM	2-CONDUCTOR 18 AWG 1 PAIR 22 AWG Shielded
P	AD-300	2-CONDUCTOR 18 AWG 1 PAIR 22 AWG Shielded
P	NDE	2-CONDUCTOR 18 AWG 1 PAIR 22 AWG Shielded
AD-WL	AD-400	WIRELESS LOCK

COMPONENT LEGEND

CR	CARD READER
DPS	DOOR POSITION SWITCH
RX	REQUEST TO EXIT
LX	LATCH BOLT MONITOR
EL	ELECTRIC EXIT DEVICE
ES	ELECTRIC STRIKE
PT	ELECTRIC PASS THROUGH DEVICE
PIM	PIM-16-485
AD-400	AD-400 WIRELESS LOCK
AD-300	AD-300 HARDWIRED LOCK
NDE	NDE WIRELESS LOCK
ES	ELECTRIC HARDWARE POWER SUPPLY
ADA	HANDICAP OPERATOR (TYPICAL)
PP	HANDICAP PUSH PLATE (TYPICAL)

CABLE DESCRIPTION

Y- WCW COMPOSITE CABLE SPECIFY RISER OR PLENUM WCW Composite Cable PN# Chord-AC-A-PL	
NON-EXTENDED CABLE	
Y-1	4-Cond. #22 AWG/STRD/NO SHIELD WCW#444381-PL
Y-2	8-Cond. #18 AWG/STRD/SHLD/W/DRAIN WCW#002352-PL
Y-3	6-Cond. #18 AWG/STRD/NO SHIELD WCW#U002391-04-PL
Y-4	4-Cond. #18 AWG/STRD/NO SHIELD WCW#442380-PL
P	2-COND. #18 AWG 1 PAIR 22 AWG Shielded WCW-92ELEMPLENTY
X- WCW COMPOSITE CABLE SPECIFY RISER OR PLENUM WCW Composite Cable PN# Chord-AC-A-EXT-PL	
EXTENDED CABLE	
X-1	4-Cond. #22 AWG/STRD/NO SHIELD WCW#444381-PL
X-2	8-Cond. #18 AWG/STRD/SHLD/W/DRAIN WCW#002352-PL
X-3	6-Cond. #18 AWG/STRD/NO SHIELD WCW#U002391-04-PL
X-4	4-Cond. #16 AWG/STRD/NO SHIELD WCW#991380-PL
P	2-COND. #18 AWG 1 PAIR 22 AWG Shielded WCW-92ELEMPLENTY

Project Name and Address

Univ of Miami
Device Elevation
SHOP DWG: SD-4

KEYED NOTES:

- ① CONCEALED DOOR POSITION SENSOR INCLUDED IN AD-400 KIT
- ② AD-400-CY-70-MS-ATH-PD (BY DIV 28)

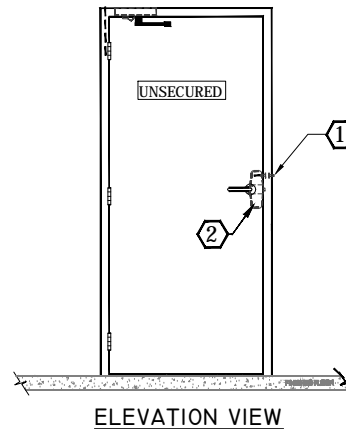
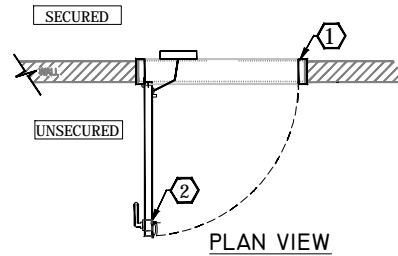

HW-7 Hardware Group No. 07
Not to Scale

HARDWARE GROUPS BASED ON
UMBS 087100 DOOR HARDWARE
STANDARDS 2017 EDITION

GENERAL NOTES
CABLE SCHEDULE

DESIGNATION	DEVICE	CABLE CONFIGURATION
Y1	DPS	4-COND. 22 AWG NO SHIELD
Y2	CR	8-COND. 18 AWG SHIELDED W/DRAIN
Y3	RX	6-COND. 18 AWG SHIELDED NO SHIELD
Y4	EL	4-COND. 18 AWG SHIELDED NO SHIELD
Y	CR-DPS- RX-EL	COMPOSITE CABLE
P	PIM	2-CONDUCTOR 18 AWG 1 PAIR 22 AWG Shielded
P	AD-300	2-CONDUCTOR 18 AWG 1 PAIR 22 AWG Shielded
P	NDE	2-CONDUCTOR 18 AWG 1 PAIR 22 AWG Shielded
AD-WL	AD-400	WIRELESS LOCK

COMPONENT LEGEND

CR	CARD READER
DPS	DOOR POSITION SWITCH
RX	REQUEST TO EXIT
LX	LATCH BOLT MONITOR
EL	ELECTRIC EXIT DEVICE
ES	ELECTRIC STRIKE
PT	ELECTRIC PASS THROUGH DEVICE
PIM	PIM-16-485
AD-400	AD-400 WIRELESS LOCK
AD-300	AD-300 HARDWIRED LOCK
NDE	NDE WIRELESS LOCK
ES	ELECTRIC HARDWARE POWER SUPPLY
ADA	HANDICAP OPERATOR (TYPICAL)
PP	HANDICAP PUSH PLATE (TYPICAL)

CABLE DESCRIPTION

Y- WCW COMPOSITE CABLE SPECIFY RISER OR PLENUM WCW Composite Cable PN# Chord-AC-A-PL		
NON-EXTENDED CABLE		
Y-1	4-Cond. #22 AWG/STRD/NO SHIELD	WCW#444381-PL
Y-2	8-Cond. #18 AWG/STRD/SHLD W/DRAIN	WCW#002352-PL
Y-3	6-Cond. #18 AWG/STRD/NO SHIELD	WCW#U002391-04-PL
Y-4	4-Cond. #18 AWG/STRD/NO SHIELD	WCW#442380-PL
P	2-COND. #18 AWG 1 PAIR 22 AWG Shielded	WCW-92ELEMPLNTY
X- WCW COMPOSITE CABLE SPECIFY RISER OR PLENUM WCW Composite Cable PN# Chord-AC-A-EXT-PL		
EXTENDED CABLE		
X-1	4-Cond. #22 AWG/STRD/NO SHIELD	WCW#444381-PL
X-2	8-Cond. #18 AWG/STRD/SHLD W/DRAIN	WCW #002352-PL
X-3	6-Cond. #18 AWG/STRD/NO SHIELD	WCW#U002391-04-PL
X-4	4-Cond. #16 AWG/STRD/NO SHIELD	WCW#991380-PL
P	2-COND. #18 AWG 1 PAIR 22 AWG Shielded	WCW-92ELEMPLNTY

Project Name and Address

Univ of Miami
Device Elevation
SHOP DWG: SD-5

KEYED NOTES:

- ① CONCEALED DOOR POSITION SENSOR INCLUDED IN AD-400 KIT
- ② AD-400-CY-70-MS-ATH-PD (BY DIV 28)

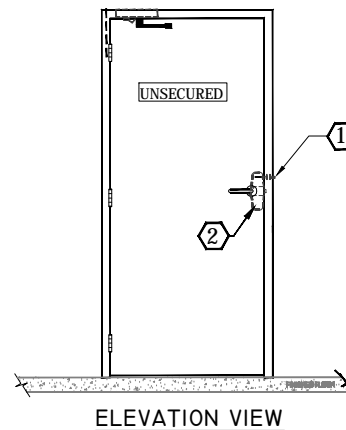
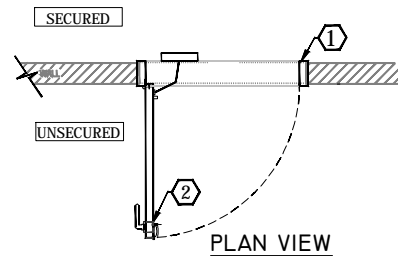

HW-8 Hardware Group No. 08
Not to Scale

HARDWARE GROUPS BASED ON
UMBS 087100 DOOR HARDWARE
STANDARDS 2017 EDITION

GENERAL NOTES
CABLE SCHEDULE

DESIGNATION	DEVICE	CABLE CONFIGURATION
Y1	DPS	4-COND. 22 AWG NO SHIELD
Y2	CR	8-COND. 18 AWG SHIELDED W/DRAIN
Y3	RX	6-COND. 18 AWG SHIELDED NO SHIELD
Y4	EL	4-COND. 18 AWG SHIELDED NO SHIELD
Y	CR-DPS-RX-EL	COMPOSITE CABLE
P	PIM	2-CONDUCTOR 18 AWG 1 PAIR 22 AWG Shielded
P	AD-300	2-CONDUCTOR 18 AWG 1 PAIR 22 AWG Shielded
P	NDE	2-CONDUCTOR 18 AWG 1 PAIR 22 AWG Shielded
AD-WL	AD-400	WIRELESS LOCK

COMPONENT LEGEND	
CR	CARD READER
DPS	DOOR POSITION SWITCH
EX	REQUEST TO EXIT
LX	LATCH BOLT MONITOR
EL	ELECTRIC EXIT DEVICE
ES	ELECTRIC STRIKE
PT	ELECTRIC PASS THROUGH DEVICE
PIM	PIM-16-485
AD-400	AD-400 WIRELESS LOCK
AD-300	AD-300 HARDWIRED LOCK
NDE	NDE WIRELESS LOCK
ES	ELECTRIC HARDWARE POWER SUPPLY
ADA	HANDICAP OPERATOR (TYPICAL)
EP	HANDICAP PUSH PLATE (TYPICAL)

CABLE DESCRIPTION		
Y- WCW COMPOSITE CABLE SPECIFY RISER OR PLENUM WCW Composite Cable PN# Cbord-AC-A-PL		
NON-EXTENDED CABLE		
Y-1	4-Cond. #22 AWG/STRD/NO SHIELD	WCW#444381-PL
Y-2	8-Cond. #18 AWG/STRD/SHLD/w/DRAIN	WCW#002352-PL
Y-3	6-Cond. #18 AWG/STRD/NO SHIELD	WCW#1002391-04-PL
Y-4	4-Cond. #18 AWG/STRD/NO SHIELD	WCW#442380-PL
P	2-COND.#18 AWG 1 PAIR 22 AWG Shielded	WCW-92ELEMPLNTY
X- WCW COMPOSITE CABLE SPECIFY RISER OR PLENUM WCW Composite Cable PN# Cbord-AC-A-EXT-PL		
EXTENDED CABLE		
X-1	4-Cond. #22 AWG/STRD/NO SHIELD	WCW#444381-PL
X-2	8-Cond. #18 AWG/STRD/SHLD/w/DRAIN	WCW#002352-PL
X-3	6-Cond. #18 AWG/STRD/NO SHIELD	WCW#1002391-04-PL
X-4	4-Cond. #18 AWG/STRD/NO SHIELD	WCW#991380-PL
P	2-COND.#18 AWG 1 PAIR 22 AWG Shielded	WCW-92ELEMPLNTY

Project Name and Address
Univ of Miami
Device Elevation
SHOP DWG: SD-6

KEYED NOTES:

- ① CONCEALED DOOR POSITION SENSOR INCLUDED IN AD-400 KIT
- ② AD-400-CY-70-MS-ATH-PD (BY DIV 28)

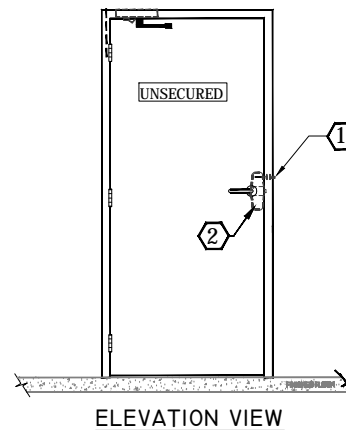
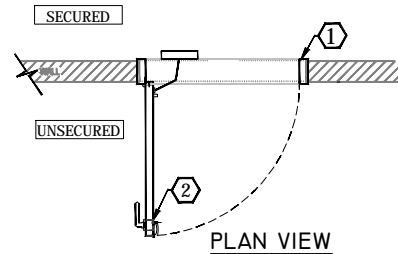

HW-9 Hardware Group No. 09
Not to Scale

HARDWARE GROUPS BASED ON
UMBS 087100 DOOR HARDWARE
STANDARDS 2017 EDITION

GENERAL NOTES
CABLE SCHEDULE

DESIGNATION	DEVICE	CABLE CONFIGURATION
Y1	DPS	4-COND. 22 AWG NO SHIELD
Y2	CR	8-COND. 18 AWG SHIELDED W/DRAIN
Y3	RX	6-COND. 18 AWG SHIELDED NO SHIELD
Y4	EL	4-COND. 18 AWG SHIELDED NO SHIELD
Y	CR-DPS-RX-EL	COMPOSITE CABLE
P	PIM	2-CONDUCTOR 18 AWG 1 PAIR 22 AWG Shielded
P	AD-300	2-CONDUCTOR 18 AWG 1 PAIR 22 AWG Shielded
P	NDE	2-CONDUCTOR 18 AWG 1 PAIR 22 AWG Shielded
AD-WL	AD-400	WIRELESS LOCK

COMPONENT LEGEND	
CR	CARD READER
DPS	DOOR POSITION SWITCH
EX	REQUEST TO EXIT
LX	LATCH BOLT MONITOR
EL	ELECTRIC EXIT DEVICE
ES	ELECTRIC STRIKE
PT	ELECTRIC PASS THROUGH DEVICE
PIM	PIM-16-485
AD-400	AD-400 WIRELESS LOCK
AD-300	AD-300 HARDWIRED LOCK
NDE	NDE WIRELESS LOCK
ES	ELECTRIC HARDWARE POWER SUPPLY
ADA	HANDICAP OPERATOR (TYPICAL)
EP	HANDICAP PUSH PLATE (TYPICAL)

CABLE DESCRIPTION		
Y- WCW COMPOSITE CABLE SPECIFY RISER OR PLENUM WCW Composite Cable PN# Cbord-AC-A-PL		
NON-EXTENDED CABLE		
Y-1	4-Cond. #22 AWG/STRD/NO SHIELD	WCW#444381-PL
Y-2	8-Cond. #18 AWG/STRD/SHLD/w/DRAIN	WCW#002352-PL
Y-3	6-Cond. #18 AWG/STRD/NO SHIELD	WCW#1002391-04-PL
Y-4	4-Cond. #18 AWG/STRD/NO SHIELD	WCW#442380-PL
P	2-COND.#18 AWG 1 PAIR 22 AWG Shielded	WCW-92ELEMPLNTY
X- WCW COMPOSITE CABLE SPECIFY RISER OR PLENUM WCW Composite Cable PN# Cbord-AC-A-EXT-PL		
EXTENDED CABLE		
X-1	4-Cond. #22 AWG/STRD/NO SHIELD	WCW#444381-PL
X-2	8-Cond. #18 AWG/STRD/SHLD/w/DRAIN	WCW#002352-PL
X-3	6-Cond. #18 AWG/STRD/NO SHIELD	WCW#1002391-04-PL
X-4	4-Cond. #18 AWG/STRD/NO SHIELD	WCW#991380-PL
P	2-COND.#18 AWG 1 PAIR 22 AWG Shielded	WCW-92ELEMPLNTY

Project Name and Address
Univ of Miami
Device Elevation
SHOP DWG: SD-7

KEYED NOTES:

- ① CONCEALED DOOR POSITION SENSOR INCLUDED IN AD-400 KIT
- ② AD-400-CY-70-MS-ATH-PD (BY DIV 28)

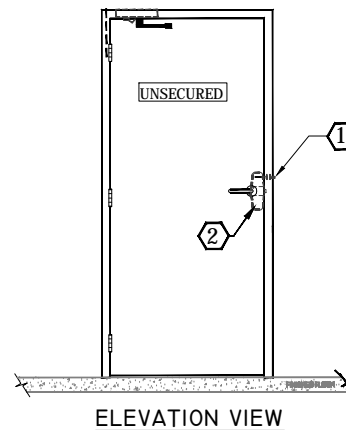
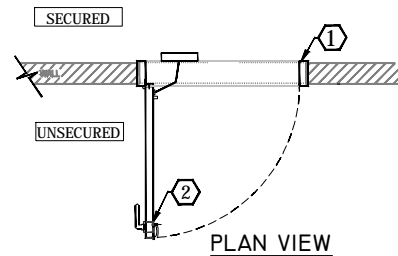

HW-10 Hardware Group No. 10
Not to Scale

HARDWARE GROUPS BASED ON
UMBS 087100 DOOR HARDWARE
STANDARDS 2017 EDITION

GENERAL NOTES
CABLE SCHEDULE

DESIGNATION	DEVICE	CABLE CONFIGURATION
Y1	DPS	4-COND. 22 AWG NO SHIELD
Y2	CR	8-COND. 18 AWG SHIELDED W/DRAIN
Y3	RX	6-COND. 18 AWG SHIELDED NO SHIELD
Y4	EL	4-COND. 18 AWG SHIELDED NO SHIELD
Y	CR-DPS-RX-EL	COMPOSITE CABLE
P	PIM	2-CONDUCTOR 18 AWG 1 PAIR 22 AWG Shielded
P	AD-300	2-CONDUCTOR 18 AWG 1 PAIR 22 AWG Shielded
P	NDE	2-CONDUCTOR 18 AWG 1 PAIR 22 AWG Shielded
AD-WL	AD-400	WIRELESS LOCK

COMPONENT LEGEND	
CR	CARD READER
DPS	DOOR POSITION SWITCH
EX	REQUEST TO EXIT
LX	LATCH BOLT MONITOR
EL	ELECTRIC EXIT DEVICE
ES	ELECTRIC STRIKE
PT	ELECTRIC PASS THROUGH DEVICE
PIM	PIM-16-485
AD-400	AD-400 WIRELESS LOCK
AD-300	AD-300 HARDWIRED LOCK
NDE	NDE WIRELESS LOCK
ES	ELECTRIC HARDWARE POWER SUPPLY
ADA	HANDICAP OPERATOR (TYPICAL)
EP	HANDICAP PUSH PLATE (TYPICAL)

CABLE DESCRIPTION		
Y- WCW COMPOSITE CABLE SPECIFY RISER OR PLENUM WCW Composite Cable PN# Cbord-AC-A-PL		
NON-EXTENDED CABLE		
Y-1	4-Cond. #22 AWG/STRD/NO SHIELD	WCW#444381-PL
Y-2	8-Cond. #18 AWG/STRD/SHLD/w/DRAIN	WCW#002352-PL
Y-3	6-Cond. #18 AWG/STRD/NO SHIELD	WCW#1002391-04-PL
Y-4	4-Cond. #18 AWG/STRD/NO SHIELD	WCW#442380-PL
P	2-COND.#18 AWG 1 PAIR 22 AWG Shielded	WCW-92ELEMPLNTY
X- WCW COMPOSITE CABLE SPECIFY RISER OR PLENUM WCW Composite Cable PN# Cbord-AC-A-EXT-PL		
EXTENDED CABLE		
X-1	4-Cond. #22 AWG/STRD/NO SHIELD	WCW#444381-PL
X-2	8-Cond. #18 AWG/STRD/SHLD/w/DRAIN	WCW#002352-PL
X-3	6-Cond. #18 AWG/STRD/NO SHIELD	WCW#1002391-04-PL
X-4	4-Cond. #18 AWG/STRD/NO SHIELD	WCW#991380-PL
P	2-COND.#18 AWG 1 PAIR 22 AWG Shielded	WCW-92ELEMPLNTY

Project Name and Address
Univ of Miami
Device Elevation
SHOP DWG: SD-8

KEYED NOTES:

- ① CONCEALED DOOR POSITION SENSOR INCLUDED IN AD-400 KIT
- ② AD-400-CY-70-MS-ATH-PD (BY DIV 28)

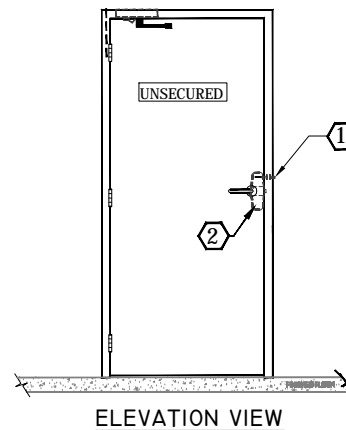
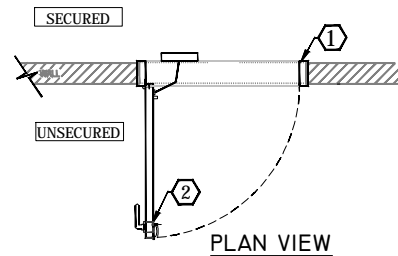

HW-11 Hardware Group No. 11
Not to Scale

HARDWARE GROUPS BASED ON
UMBS 087100 DOOR HARDWARE
STANDARDS 2017 EDITION

GENERAL NOTES
CABLE SCHEDULE

DESIGNATION	DEVICE	CABLE CONFIGURATION
Y1	DPS	4-COND. 22 AWG NO SHIELD
Y2	CR	8-COND. 18 AWG SHIELDED W/DRAIN
Y3	RX	6-COND. 18 AWG SHIELDED NO SHIELD
Y4	EL	4-COND. 18 AWG SHIELDED NO SHIELD
Y	CR-DPS-RX-EL	COMPOSITE CABLE
P	PIM	2-CONDUCTOR 18 AWG 1 PAIR 22 AWG Shielded
P	AD-300	2-CONDUCTOR 18 AWG 1 PAIR 22 AWG Shielded
P	NDE	2-CONDUCTOR 18 AWG 1 PAIR 22 AWG Shielded
AD-WL	AD-400	WIRELESS LOCK

COMPONENT LEGEND	
CR	CARD READER
DPS	DOOR POSITION SWITCH
EX	REQUEST TO EXIT
LX	LATCH BOLT MONITOR
EL	ELECTRIC EXIT DEVICE
ES	ELECTRIC STRIKE
PT	ELECTRIC PASS THROUGH DEVICE
PIM	PIM-16-485
AD-400	AD-400 WIRELESS LOCK
AD-300	AD-300 HARDWIRED LOCK
NDE	NDE WIRELESS LOCK
ES	ELECTRIC HARDWARE POWER SUPPLY
ADA	HANDICAP OPERATOR (TYPICAL)
EP	HANDICAP PUSH PLATE (TYPICAL)

CABLE DESCRIPTION		
Y- WCW COMPOSITE CABLE SPECIFY RISER OR PLENUM WCW Composite Cable PN# Cbord-AC-A-PL		
NON-EXTENDED CABLE		
Y-1	4-Cond. #22 AWG/STRD/NO SHIELD	WCW#444381-PL
Y-2	8-Cond. #18 AWG/STRD/SHLD/w/DRAIN	WCW#002352-PL
Y-3	6-Cond. #18 AWG/STRD/NO SHIELD	WCW#1002391-04-PL
Y-4	4-Cond. #18 AWG/STRD/NO SHIELD	WCW#442380-PL
P	2-COND.#18 AWG 1 PAIR 22 AWG Shielded	WCW-92ELEMPLNTY
X- WCW COMPOSITE CABLE SPECIFY RISER OR PLENUM WCW Composite Cable PN# Cbord-AC-A-EXT-PL		
EXTENDED CABLE		
X-1	4-Cond. #22 AWG/STRD/NO SHIELD	WCW#444381-PL
X-2	8-Cond. #18 AWG/STRD/SHLD/w/DRAIN	WCW#002352-PL
X-3	6-Cond. #18 AWG/STRD/NO SHIELD	WCW#1002391-04-PL
X-4	4-Cond. #18 AWG/STRD/NO SHIELD	WCW#991380-PL
P	2-COND.#18 AWG 1 PAIR 22 AWG Shielded	WCW-92ELEMPLNTY

Project Name and Address
Univ of Miami
Device Elevation
SHOP DWG: SD-9

KEYED NOTES:

- ① CONCEALED DOOR POSITION SENSOR INCLUDED IN AD-400 KIT
- ② AD-400-CY-70-MS-ATH-PD (BY DIV 28)

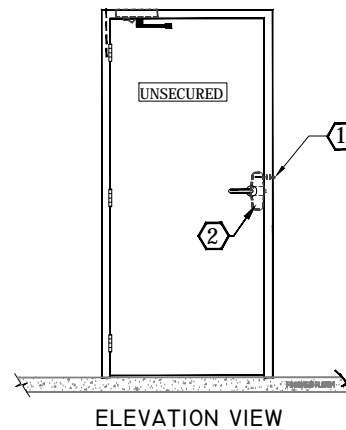
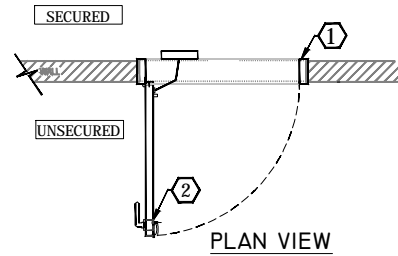

HW-12 Hardware Group No. 12
Not to Scale

HARDWARE GROUPS BASED ON
UMBS 087100 DOOR HARDWARE
STANDARDS 2017 EDITION

GENERAL NOTES
CABLE SCHEDULE

DESIGNATION	DEVICE	CABLE CONFIGURATION
Y1	DPS	4-COND. 22 AWG NO SHIELD
Y2	CR	8-COND. 18 AWG SHIELDED W/DRAIN
Y3	RX	6-COND. 18 AWG SHIELDED NO SHIELD
Y4	EL	4-COND. 18 AWG SHIELDED NO SHIELD
Y	CR-DPS-RX-EL	COMPOSITE CABLE
P	PIM	2-CONDUCTOR 18 AWG 1 PAIR 22 AWG Shielded
P	AD-300	2-CONDUCTOR 18 AWG 1 PAIR 22 AWG Shielded
P	NDE	2-CONDUCTOR 18 AWG 1 PAIR 22 AWG Shielded
AD-WL	AD-400	WIRELESS LOCK

COMPONENT LEGEND	
CR	CARD READER
DPS	DOOR POSITION SWITCH
EX	REQUEST TO EXIT
LX	LATCH BOLT MONITOR
EL	ELECTRIC EXIT DEVICE
ES	ELECTRIC STRIKE
PT	ELECTRIC PASS THROUGH DEVICE
PIM	PIM-16-485
AD-400	AD-400 WIRELESS LOCK
AD-300	AD-300 HARDWIRED LOCK
NDE	NDE WIRELESS LOCK
ES	ELECTRIC HARDWARE POWER SUPPLY
ADA	HANDICAP OPERATOR (TYPICAL)
EP	HANDICAP PUSH PLATE (TYPICAL)

CABLE DESCRIPTION		
Y- WCW COMPOSITE CABLE SPECIFY RISER OR PLENUM WCW Composite Cable PN# Cbord-AC-A-PL		
NON-EXTENDED CABLE		
Y-1	4-Cond. #22 AWG/STRD/NO SHIELD	WCW#444381-PL
Y-2	8-Cond. #18 AWG/STRD/SHLD/w/DRAIN	WCW#002352-PL
Y-3	6-Cond. #18 AWG/STRD/NO SHIELD	WCW#1002391-04-PL
Y-4	4-Cond. #18 AWG/STRD/NO SHIELD	WCW#442380-PL
P	2-COND.#18 AWG 1 PAIR 22 AWG Shielded	WCW-92ELEMPLNTY
X- WCW COMPOSITE CABLE SPECIFY RISER OR PLENUM WCW Composite Cable PN# Cbord-AC-A-EXT-PL		
EXTENDED CABLE		
X-1	4-Cond. #22 AWG/STRD/NO SHIELD	WCW#444381-PL
X-2	8-Cond. #18 AWG/STRD/SHLD/w/DRAIN	WCW#002352-PL
X-3	6-Cond. #18 AWG/STRD/NO SHIELD	WCW#1002391-04-PL
X-4	4-Cond. #18 AWG/STRD/NO SHIELD	WCW#991380-PL
P	2-COND.#18 AWG 1 PAIR 22 AWG Shielded	WCW-92ELEMPLNTY

Project Name and Address
Univ of Miami
Device Elevation
SHOP DWG: SD-10

KEYED NOTES:

- ① CONCEALED DOOR POSITION SENSOR INCLUDED IN AD-400 KIT
- ② AD-400-CY-70-MS-ATH-PD (BY DIV 28)

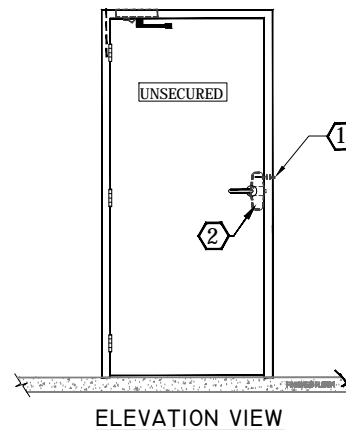
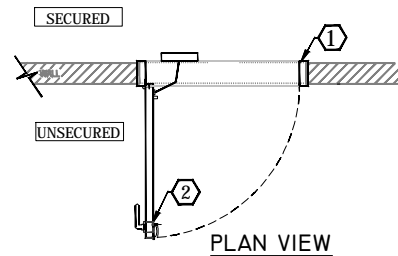

HW-13 Hardware Group No. 13
Not to Scale

HARDWARE GROUPS BASED ON
UMBS 087100 DOOR HARDWARE
STANDARDS 2017 EDITION

GENERAL NOTES
CABLE SCHEDULE

DESIGNATION	DEVICE	CABLE CONFIGURATION
Y1	DPS	4-COND. 22 AWG NO SHIELD
Y2	CR	8-COND. 18 AWG SHIELDED W/DRAIN
Y3	RX	6-COND. 18 AWG SHIELDED NO SHIELD
Y4	EL	4-COND. 18 AWG SHIELDED NO SHIELD
Y	CR-DPS-RX-EL	COMPOSITE CABLE
P	PIM	2-CONDUCTOR 18 AWG 1 PAIR 22 AWG Shielded
P	AD-300	2-CONDUCTOR 18 AWG 1 PAIR 22 AWG Shielded
P	NDE	2-CONDUCTOR 18 AWG 1 PAIR 22 AWG Shielded
AD-WL	AD-400	WIRELESS LOCK

COMPONENT LEGEND

CR	CARD READER
DPS	DOOR POSITION SWITCH
EX	REQUEST TO EXIT
LX	LATCH BOLT MONITOR
EL	ELECTRIC EXIT DEVICE
ES	ELECTRIC STRIKE
PT	ELECTRIC PASS THROUGH DEVICE
PIM	PIM-16-485
AD-400	AD-400 WIRELESS LOCK
AD-300	AD-300 HARDWIRED LOCK
NDE	NDE WIRELESS LOCK
ES	ELECTRIC HARDWARE POWER SUPPLY
ADA	HANDICAP OPERATOR (TYPICAL)
EP	HANDICAP PUSH PLATE (TYPICAL)

CABLE DESCRIPTION

Y- WCW COMPOSITE CABLE
SPECIFY RISER OR PLENUM
WCW Composite Cable
PN# Cbord-AC-A-PL

NON-EXTENDED CABLE

Y-1	4-Cond. #22 AWG/STRD/NO SHIELD	WCW#444381-PL
Y-2	8-Cond. #18 AWG/STRD/SHLD/w/DRAIN	WCW#002352-PL
Y-3	6-Cond. #18 AWG/STRD/NO SHIELD	WCW#1002391-04-PL
Y-4	4-Cond. #18 AWG/STRD/NO SHIELD	WCW#442380-PL
P	2-COND.#18 AWG 1 PAIR 22 AWG Shielded	WCW-92ELEMPLNTY

X- WCW COMPOSITE CABLE
SPECIFY RISER OR PLENUM
WCW Composite Cable
PN# Cbord-AC-A-EXT-PL

EXTENDED CABLE

X-1	4-Cond. #22 AWG/STRD/NO SHIELD	WCW#444381-PL
X-2	8-Cond. #18 AWG/STRD/SHLD/w/DRAIN	WCW#002352-PL
X-3	6-Cond. #18 AWG/STRD/NO SHIELD	WCW#1002391-04-PL
X-4	4-Cond. #18 AWG/STRD/NO SHIELD	WCW#991380-PL
P	2-COND.#18 AWG 1 PAIR 22 AWG Shielded	WCW-92ELEMPLNTY

Project Name and Address

Univ of Miami
Device Elevation
SHOP DWG: SD-11

KEYED NOTES:

- ① CONCEALED DOOR POSITION SENSOR INCLUDED IN AD-400 KIT
- ② AD-400-CY-70-MS-ATH-PD (BY DIV 28)

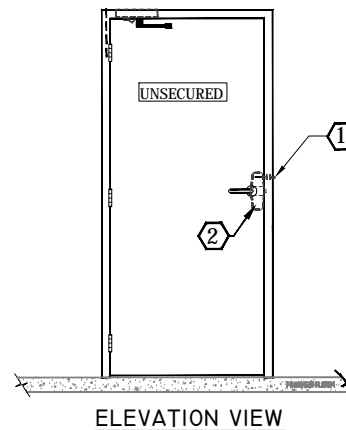
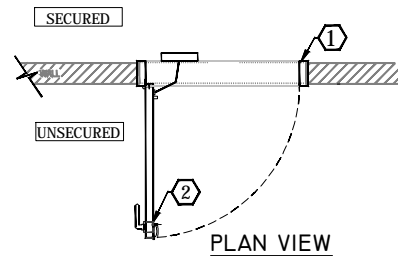

HW-14 Hardware Group No. 14
Not to Scale

HARDWARE GROUPS BASED ON
UMBS 087100 DOOR HARDWARE
STANDARDS 2017 EDITION

GENERAL NOTES
CABLE SCHEDULE

DESIGNATION	DEVICE	CABLE CONFIGURATION
Y1	DPS	4-COND. 22 AWG NO SHIELD
Y2	CR	8-COND. 18 AWG SHIELDED W/DRAIN
Y3	RX	6-COND. 18 AWG SHIELDED NO SHIELD
Y4	EL	4-COND. 18 AWG SHIELDED NO SHIELD
Y	CR-DPS-RX-EL	COMPOSITE CABLE
P	PIM	2-CONDUCTOR 18 AWG 1 PAIR 22 AWG Shielded
P	AD-300	2-CONDUCTOR 18 AWG 1 PAIR 22 AWG Shielded
P	NDE	2-CONDUCTOR 18 AWG 1 PAIR 22 AWG Shielded
AD-WL	AD-400	WIRELESS LOCK

COMPONENT LEGEND

CR	CARD READER
DPS	DOOR POSITION SWITCH
EX	REQUEST TO EXIT
LX	LATCH BOLT MONITOR
EL	ELECTRIC EXIT DEVICE
ES	ELECTRIC STRIKE
PT	ELECTRIC PASS THROUGH DEVICE
PIM	PIM-16-485
AD-400	AD-400 WIRELESS LOCK
AD-300	AD-300 HARDWIRED LOCK
NDE	NDE WIRELESS LOCK
ES	ELECTRIC HARDWARE POWER SUPPLY
ADA	HANDICAP OPERATOR (TYPICAL)
EP	HANDICAP PUSH PLATE (TYPICAL)

CABLE DESCRIPTION

Y- WCW COMPOSITE CABLE
SPECIFY RISER OR PLENUM
WCW Composite Cable
PN# Cbord-AC-A-PL

NON-EXTENDED CABLE

Y-1	4-Cond. #22 AWG/STRD/NO SHIELD	WCW#444381-PL
Y-2	8-Cond. #18 AWG/STRD/SHLD/w/DRAIN	WCW#002352-PL
Y-3	6-Cond. #18 AWG/STRD/NO SHIELD	WCW#1002391-04-PL
Y-4	4-Cond. #18 AWG/STRD/NO SHIELD	WCW#442380-PL
P	2-COND.#18 AWG 1 PAIR 22 AWG Shielded	WCW-92ELEMPLNTY

X- WCW COMPOSITE CABLE
SPECIFY RISER OR PLENUM
WCW Composite Cable
PN# Cbord-AC-A-EXT-PL

EXTENDED CABLE

X-1	4-Cond. #22 AWG/STRD/NO SHIELD	WCW#444381-PL
X-2	8-Cond. #18 AWG/STRD/SHLD/w/DRAIN	WCW#002352-PL
X-3	6-Cond. #18 AWG/STRD/NO SHIELD	WCW#1002391-04-PL
X-4	4-Cond. #18 AWG/STRD/NO SHIELD	WCW#991380-PL
P	2-COND.#18 AWG 1 PAIR 22 AWG Shielded	WCW-92ELEMPLNTY

Project Name and Address

Univ of Miami
Device Elevation
SHOP DWG: SD-12

KEYED NOTES:

- ① CONCEALED DOOR POSITION SENSOR INCLUDED IN AD-400 KIT
- ② AD-400-CY-70-MS-ATH-PD (BY DIV 28)

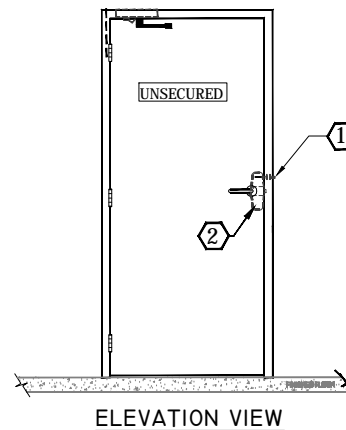
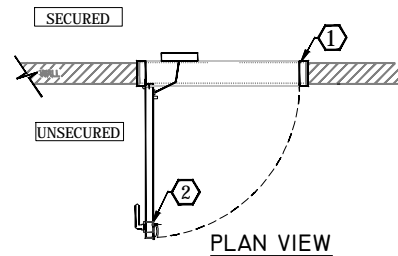

HW-15 Hardware Group No. 15
Not to Scale

HARDWARE GROUPS BASED ON
UMBS 087100 DOOR HARDWARE
STANDARDS 2017 EDITION

GENERAL NOTES
CABLE SCHEDULE

DESIGNATION	DEVICE	CABLE CONFIGURATION
Y1	DPS	4-COND. 22 AWG NO SHIELD
Y2	CR	8-COND. 18 AWG SHIELDED W/DRAIN
Y3	RX	6-COND. 18 AWG SHIELDED NO SHIELD
Y4	EL	4-COND. 18 AWG SHIELDED NO SHIELD
Y	CR-DPS-RX-EL	COMPOSITE CABLE
P	PIM	2-CONDUCTOR 18 AWG 1 PAIR 22 AWG Shielded
P	AD-300	2-CONDUCTOR 18 AWG 1 PAIR 22 AWG Shielded
P	NDE	2-CONDUCTOR 18 AWG 1 PAIR 22 AWG Shielded
AD-WL	AD-400	WIRELESS LOCK

COMPONENT LEGEND	
CR	CARD READER
DPS	DOOR POSITION SWITCH
EX	REQUEST TO EXIT
LX	LATCH BOLT MONITOR
EL	ELECTRIC EXIT DEVICE
ES	ELECTRIC STRIKE
PT	ELECTRIC PASS THROUGH DEVICE
PIM	PIM-16-485
AD-400	AD-400 WIRELESS LOCK
AD-300	AD-300 HARDWIRED LOCK
NDE	NDE WIRELESS LOCK
ES	ELECTRIC HARDWARE POWER SUPPLY
ADA	HANDICAP OPERATOR (TYPICAL)
EP	HANDICAP PUSH PLATE (TYPICAL)

CABLE DESCRIPTION		
Y- WCW COMPOSITE CABLE SPECIFY RISER OR PLENUM WCW Composite Cable PN# Cbord-AC-A-PL		
NON-EXTENDED CABLE		
Y-1	4-Cond. #22 AWG/STRD/NO SHIELD	WCW#444381-PL
Y-2	8-Cond. #18 AWG/STRD/SHLD/w/DRAIN	WCW#002352-PL
Y-3	6-Cond. #18 AWG/STRD/NO SHIELD	WCW#1002391-04-PL
Y-4	4-Cond. #18 AWG/STRD/NO SHIELD	WCW#442380-PL
P	2-COND.#18 AWG 1 PAIR 22 AWG Shielded	WCW-92ELEMPLNTY
X- WCW COMPOSITE CABLE SPECIFY RISER OR PLENUM WCW Composite Cable PN# Cbord-AC-A-EXT-PL		
EXTENDED CABLE		
X-1	4-Cond. #22 AWG/STRD/NO SHIELD	WCW#444381-PL
X-2	8-Cond. #18 AWG/STRD/SHLD/w/DRAIN	WCW#002352-PL
X-3	6-Cond. #18 AWG/STRD/NO SHIELD	WCW#1002391-04-PL
X-4	4-Cond. #18 AWG/STRD/NO SHIELD	WCW#991380-PL
P	2-COND.#18 AWG 1 PAIR 22 AWG Shielded	WCW-92ELEMPLNTY

Project Name and Address
Univ of Miami
Device Elevation
SHOP DWG: SD-13

KEYED NOTES:

- ① CONCEALED DOOR POSITION SENSOR INCLUDED IN AD-400 KIT
- ② AD-400-CY-70-MS-ATH-PD (BY DIV 28)

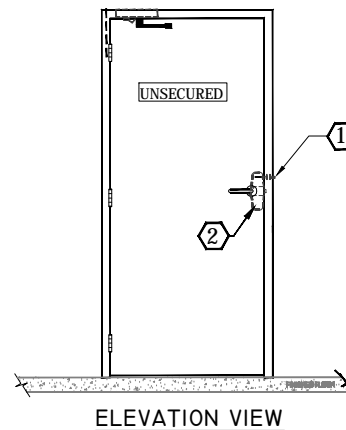
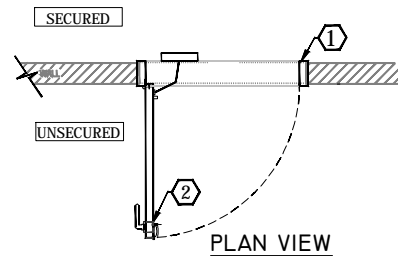

HW-16 Hardware Group No. 16
Not to Scale

HARDWARE GROUPS BASED ON
UMBS 087100 DOOR HARDWARE
STANDARDS 2017 EDITION

GENERAL NOTES
CABLE SCHEDULE

DESIGNATION	DEVICE	CABLE CONFIGURATION
Y1	DPS	4-COND. 22 AWG NO SHIELD
Y2	CR	8-COND. 18 AWG SHIELDED W/DRAIN
Y3	RX	6-COND. 18 AWG SHIELDED NO SHIELD
Y4	EL	4-COND. 18 AWG SHIELDED NO SHIELD
Y	CR-DPS-RX-EL	COMPOSITE CABLE
P	PIM	2-CONDUCTOR 18 AWG 1 PAIR 22 AWG Shielded
P	AD-300	2-CONDUCTOR 18 AWG 1 PAIR 22 AWG Shielded
P	NDE	2-CONDUCTOR 18 AWG 1 PAIR 22 AWG Shielded
AD-WL	AD-400	WIRELESS LOCK

COMPONENT LEGEND	
CR	CARD READER
DPS	DOOR POSITION SWITCH
EX	REQUEST TO EXIT
LX	LATCH BOLT MONITOR
EL	ELECTRIC EXIT DEVICE
ES	ELECTRIC STRIKE
PT	ELECTRIC PASS THROUGH DEVICE
PIM	PIM-16-485
AD-400	AD-400 WIRELESS LOCK
AD-300	AD-300 HARDWIRED LOCK
NDE	NDE WIRELESS LOCK
ES	ELECTRIC HARDWARE POWER SUPPLY
ADA	HANDICAP OPERATOR (TYPICAL)
EP	HANDICAP PUSH PLATE (TYPICAL)

CABLE DESCRIPTION		
Y- WCW COMPOSITE CABLE SPECIFY RISER OR PLENUM WCW Composite Cable PN# Cbord-AC-A-PL		
NON-EXTENDED CABLE		
Y-1	4-Cond. #22 AWG/STRD/NO SHIELD	WCW#444381-PL
Y-2	8-Cond. #18 AWG/STRD/SHLD/w/DRAIN	WCW#002352-PL
Y-3	6-Cond. #18 AWG/STRD/NO SHIELD	WCW#1002391-04-PL
Y-4	4-Cond. #18 AWG/STRD/NO SHIELD	WCW#442380-PL
P	2-COND.#18 AWG 1 PAIR 22 AWG Shielded	WCW-92ELEMPLNTY
X- WCW COMPOSITE CABLE SPECIFY RISER OR PLENUM WCW Composite Cable PN# Cbord-AC-A-EXT-PL		
EXTENDED CABLE		
X-1	4-Cond. #22 AWG/STRD/NO SHIELD	WCW#444381-PL
X-2	8-Cond. #18 AWG/STRD/SHLD/w/DRAIN	WCW#002352-PL
X-3	6-Cond. #18 AWG/STRD/NO SHIELD	WCW#1002391-04-PL
X-4	4-Cond. #18 AWG/STRD/NO SHIELD	WCW#991380-PL
P	2-COND.#18 AWG 1 PAIR 22 AWG Shielded	WCW-92ELEMPLNTY

Project Name and Address
Univ of Miami
Device Elevation
SHOP DWG: SD-14

KEYED NOTES:

- ① CONCEALED DOOR POSITION SENSOR INCLUDED IN AD-400 KIT
- ② AD-400-CY-70-MS-ATH-PD (BY DIV 28)

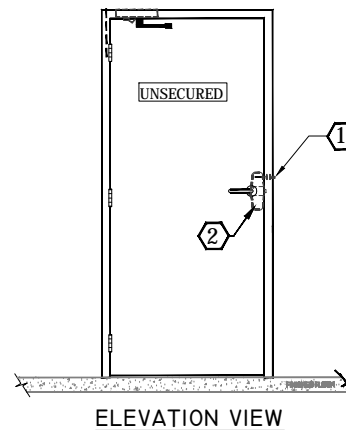
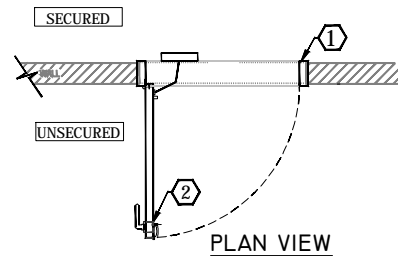

HW-17 Hardware Group No. 17
Not to Scale

HARDWARE GROUPS BASED ON
UMBS 087100 DOOR HARDWARE
STANDARDS 2017 EDITION

GENERAL NOTES
CABLE SCHEDULE

DESIGNATION	DEVICE	CABLE CONFIGURATION
Y1	DPS	4-COND. 22 AWG NO SHIELD
Y2	CR	8-COND. 18 AWG SHIELDED W/DRAIN
Y3	RX	6-COND. 18 AWG SHIELDED NO SHIELD
Y4	EL	4-COND. 18 AWG SHIELDED NO SHIELD
Y	CR-DPS-RX-EL	COMPOSITE CABLE
P	PIM	2-CONDUCTOR 18 AWG 1 PAIR 22 AWG Shielded
P	AD-300	2-CONDUCTOR 18 AWG 1 PAIR 22 AWG Shielded
P	NDE	2-CONDUCTOR 18 AWG 1 PAIR 22 AWG Shielded
AD-WL	AD-400	WIRELESS LOCK

COMPONENT LEGEND	
CR	CARD READER
DPS	DOOR POSITION SWITCH
EX	REQUEST TO EXIT
LX	LATCH BOLT MONITOR
EL	ELECTRIC EXIT DEVICE
ES	ELECTRIC STRIKE
PT	ELECTRIC PASS THROUGH DEVICE
PIM	PIM-16-485
AD-400	AD-400 WIRELESS LOCK
AD-300	AD-300 HARDWIRED LOCK
NDE	NDE WIRELESS LOCK
ES	ELECTRIC HARDWARE POWER SUPPLY
ADA	HANDICAP OPERATOR (TYPICAL)
EP	HANDICAP PUSH PLATE (TYPICAL)

CABLE DESCRIPTION		
Y- WCW COMPOSITE CABLE SPECIFY RISER OR PLENUM WCW Composite Cable PN# Cbord-AC-A-PL		
NON-EXTENDED CABLE		
Y-1	4-Cond. #22 AWG/STRD/NO SHIELD	WCW#444381-PL
Y-2	8-Cond. #18 AWG/STRD/SHLD/w/DRAIN	WCW#002352-PL
Y-3	6-Cond. #18 AWG/STRD/NO SHIELD	WCW#1002391-04-PL
Y-4	4-Cond. #18 AWG/STRD/NO SHIELD	WCW#442380-PL
P	2-COND.#18 AWG 1 PAIR 22 AWG Shielded	WCW-92ELEMPLNTY
X- WCW COMPOSITE CABLE SPECIFY RISER OR PLENUM WCW Composite Cable PN# Cbord-AC-A-EXT-PL		
EXTENDED CABLE		
X-1	4-Cond. #22 AWG/STRD/NO SHIELD	WCW#444381-PL
X-2	8-Cond. #18 AWG/STRD/SHLD/w/DRAIN	WCW#002352-PL
X-3	6-Cond. #18 AWG/STRD/NO SHIELD	WCW#1002391-04-PL
X-4	4-Cond. #18 AWG/STRD/NO SHIELD	WCW#991380-PL
P	2-COND.#18 AWG 1 PAIR 22 AWG Shielded	WCW-92ELEMPLNTY

Project Name and Address
Univ of Miami
Device Elevation
SHOP DWG: SD-15

KEYED NOTES:

- ① CONCEALED DOOR POSITION SENSOR INCLUDED IN AD-400 KIT
- ② AD-400-CY-70-MS-ATH-PD (BY DIV 28)

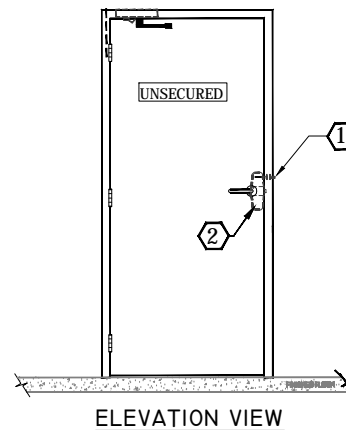
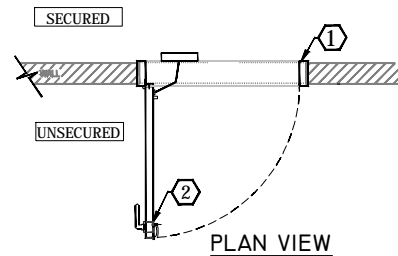

HW-18 Hardware Group No. 18
Not to Scale

HARDWARE GROUPS BASED ON
UMBS 087100 DOOR HARDWARE
STANDARDS 2017 EDITION

GENERAL NOTES
CABLE SCHEDULE

DESIGNATION	DEVICE	CABLE CONFIGURATION
Y1	DPS	4-COND. 22 AWG NO SHIELD
Y2	CR	8-COND. 18 AWG SHIELDED W/DRAIN
Y3	RX	6-COND. 18 AWG SHIELDED NO SHIELD
Y4	EL	4-COND. 18 AWG SHIELDED NO SHIELD
Y	CR-DPS-RX-EL	COMPOSITE CABLE
P	PIM	2-CONDUCTOR 18 AWG 1 PAIR 22 AWG Shielded
P	AD-300	2-CONDUCTOR 18 AWG 1 PAIR 22 AWG Shielded
P	NDE	2-CONDUCTOR 18 AWG 1 PAIR 22 AWG Shielded
AD-WL	AD-400	WIRELESS LOCK

COMPONENT LEGEND	
CR	CARD READER
DPS	DOOR POSITION SWITCH
EX	REQUEST TO EXIT
LX	LATCH BOLT MONITOR
EL	ELECTRIC EXIT DEVICE
ES	ELECTRIC STRIKE
PT	ELECTRIC PASS THROUGH DEVICE
PIM	PIM-16-485
AD-400	AD-400 WIRELESS LOCK
AD-300	AD-300 HARDWIRED LOCK
NDE	NDE WIRELESS LOCK
ES	ELECTRIC HARDWARE POWER SUPPLY
ADA	HANDICAP OPERATOR (TYPICAL)
EP	HANDICAP PUSH PLATE (TYPICAL)

CABLE DESCRIPTION		
Y- WCW COMPOSITE CABLE SPECIFY RISER OR PLENUM WCW Composite Cable PN# Cbord-AC-A-PL		
NON-EXTENDED CABLE		
Y-1	4-Cond. #22 AWG/STRD/NO SHIELD	WCW#444381-PL
Y-2	8-Cond. #18 AWG/STRD/SHLD/w/DRAIN	WCW#002352-PL
Y-3	6-Cond. #18 AWG/STRD/NO SHIELD	WCW#1002391-04-PL
Y-4	4-Cond. #18 AWG/STRD/NO SHIELD	WCW#442380-PL
P	2-COND.#18 AWG 1 PAIR 22 AWG Shielded	WCW-92ELEMPLNTY
X- WCW COMPOSITE CABLE SPECIFY RISER OR PLENUM WCW Composite Cable PN# Cbord-AC-A-EXT-PL		
EXTENDED CABLE		
X-1	4-Cond. #22 AWG/STRD/NO SHIELD	WCW#444381-PL
X-2	8-Cond. #18 AWG/STRD/SHLD/w/DRAIN	WCW#002352-PL
X-3	6-Cond. #18 AWG/STRD/NO SHIELD	WCW#1002391-04-PL
X-4	4-Cond. #18 AWG/STRD/NO SHIELD	WCW#991380-PL
P	2-COND.#18 AWG 1 PAIR 22 AWG Shielded	WCW-92ELEMPLNTY

Project Name and Address
Univ of Miami
Device Elevation
SHOP DWG: SD-16

KEYED NOTES:

- ① CONCEALED DOOR POSITION SENSOR INCLUDED IN AD-400 KIT
- ② AD-400-CY-70-MS-ATH-PD (BY DIV 28)

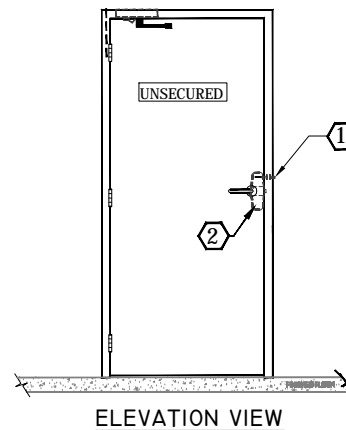
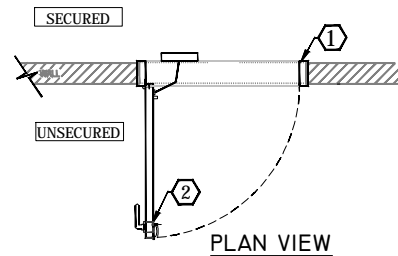

HW-19 Hardware Group No. 19
Not to Scale

HARDWARE GROUPS BASED ON
UMBS 087100 DOOR HARDWARE
STANDARDS 2017 EDITION

GENERAL NOTES
CABLE SCHEDULE

DESIGNATION	DEVICE	CABLE CONFIGURATION
Y1	DPS	4-COND. 22 AWG NO SHIELD
Y2	CR	8-COND. 18 AWG SHIELDED W/DRAIN
Y3	RX	6-COND. 18 AWG SHIELDED NO SHIELD
Y4	EL	4-COND. 18 AWG SHIELDED NO SHIELD
Y	CR-DPS-RX-EL	COMPOSITE CABLE
P	PIM	2-CONDUCTOR 18 AWG 1 PAIR 22 AWG Shielded
P	AD-300	2-CONDUCTOR 18 AWG 1 PAIR 22 AWG Shielded
P	NDE	2-CONDUCTOR 18 AWG 1 PAIR 22 AWG Shielded
AD-WL	AD-400	WIRELESS LOCK

COMPONENT LEGEND

CR	CARD READER
DPS	DOOR POSITION SWITCH
EX	REQUEST TO EXIT
LX	LATCH BOLT MONITOR
EL	ELECTRIC EXIT DEVICE
ES	ELECTRIC STRIKE
PT	ELECTRIC PASS THROUGH DEVICE
PIM	PIM-16-485
AD-400	AD-400 WIRELESS LOCK
AD-300	AD-300 HARDWIRED LOCK
NDE	NDE WIRELESS LOCK
ES	ELECTRIC HARDWARE POWER SUPPLY
ADA	HANDICAP OPERATOR (TYPICAL)
EP	HANDICAP PUSH PLATE (TYPICAL)

CABLE DESCRIPTION

Y- WCW COMPOSITE CABLE
SPECIFY RISER OR PLENUM
WCW Composite Cable
PN# Cbord-AC-A-PL

NON-EXTENDED CABLE

Y-1	4-Cond. #22 AWG/STRD/NO SHIELD	WCW#444381-PL
Y-2	8-Cond. #18 AWG/STRD/SHLD/w/DRAIN	WCW#002352-PL
Y-3	6-Cond. #18 AWG/STRD/NO SHIELD	WCW#1002391-04-PL
Y-4	4-Cond. #18 AWG/STRD/NO SHIELD	WCW#442380-PL
P	2-COND.#18 AWG 1 PAIR 22 AWG Shielded	WCW-92ELEMPLNTY

X- WCW COMPOSITE CABLE
SPECIFY RISER OR PLENUM
WCW Composite Cable
PN# Cbord-AC-A-EXT-PL

EXTENDED CABLE

X-1	4-Cond. #22 AWG/STRD/NO SHIELD	WCW#444381-PL
X-2	8-Cond. #18 AWG/STRD/SHLD/w/DRAIN	WCW#002352-PL
X-3	6-Cond. #18 AWG/STRD/NO SHIELD	WCW#1002391-04-PL
X-4	4-Cond. #18 AWG/STRD/NO SHIELD	WCW#991380-PL
P	2-COND.#18 AWG 1 PAIR 22 AWG Shielded	WCW-92ELEMPLNTY

Project Name and Address

Univ of Miami
Device Elevation
SHOP DWG: SD-17

KEYED NOTES:

- ① CONCEALED DOOR POSITION SENSOR INCLUDED IN AD-400 KIT
- ② AD-400-CY-70-MS-ATH-PD (BY DIV 28)

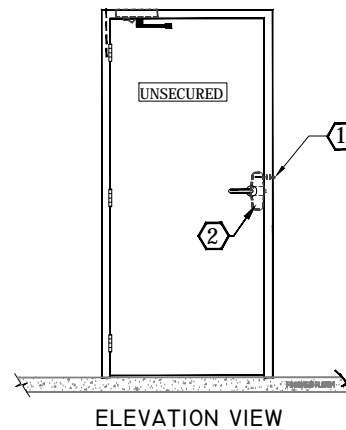
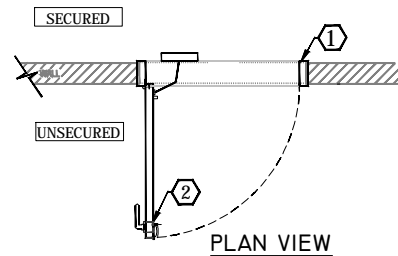

HW-20 Hardware Group No. 20
Not to Scale

HARDWARE GROUPS BASED ON
UMBS 087100 DOOR HARDWARE
STANDARDS 2017 EDITION

GENERAL NOTES
CABLE SCHEDULE

DESIGNATION	DEVICE	CABLE CONFIGURATION
Y1	DPS	4-COND. 22 AWG NO SHIELD
Y2	CR	8-COND. 18 AWG SHIELDED W/DRAIN
Y3	RX	6-COND. 18 AWG SHIELDED NO SHIELD
Y4	EL	4-COND. 18 AWG SHIELDED NO SHIELD
Y	CR-DPS-RX-EL	COMPOSITE CABLE
P	PIM	2-CONDUCTOR 18 AWG 1 PAIR 22 AWG Shielded
P	AD-300	2-CONDUCTOR 18 AWG 1 PAIR 22 AWG Shielded
P	NDE	2-CONDUCTOR 18 AWG 1 PAIR 22 AWG Shielded
AD-WL	AD-400	WIRELESS LOCK

COMPONENT LEGEND	
CR	CARD READER
DPS	DOOR POSITION SWITCH
EX	REQUEST TO EXIT
LX	LATCH BOLT MONITOR
EL	ELECTRIC EXIT DEVICE
ES	ELECTRIC STRIKE
PT	ELECTRIC PASS THROUGH DEVICE
PIM	PIM-16-485
AD-400	AD-400 WIRELESS LOCK
AD-300	AD-300 HARDWIRED LOCK
NDE	NDE WIRELESS LOCK
ES	ELECTRIC HARDWARE POWER SUPPLY
ADA	HANDICAP OPERATOR (TYPICAL)
EP	HANDICAP PUSH PLATE (TYPICAL)

CABLE DESCRIPTION		
Y- WCW COMPOSITE CABLE SPECIFY RISER OR PLENUM WCW Composite Cable PN# Cbord-AC-A-PL		
NON-EXTENDED CABLE		
Y-1	4-Cond. #22 AWG/STRD/NO SHIELD	WCW#444381-PL
Y-2	8-Cond. #18 AWG/STRD/SHLD/w/DRAIN	WCW#002352-PL
Y-3	6-Cond. #18 AWG/STRD/NO SHIELD	WCW#1002391-04-PL
Y-4	4-Cond. #18 AWG/STRD/NO SHIELD	WCW#442380-PL
P	2-COND.#18 AWG 1 PAIR 22 AWG Shielded	WCW-92ELEMPLNTY
X- WCW COMPOSITE CABLE SPECIFY RISER OR PLENUM WCW Composite Cable PN# Cbord-AC-A-EXT-PL		
EXTENDED CABLE		
X-1	4-Cond. #22 AWG/STRD/NO SHIELD	WCW#444381-PL
X-2	8-Cond. #18 AWG/STRD/SHLD/w/DRAIN	WCW#002352-PL
X-3	6-Cond. #18 AWG/STRD/NO SHIELD	WCW#1002391-04-PL
X-4	4-Cond. #18 AWG/STRD/NO SHIELD	WCW#991380-PL
P	2-COND.#18 AWG 1 PAIR 22 AWG Shielded	WCW-92ELEMPLNTY

Project Name and Address
Univ of Miami
Device Elevation
SHOP DWG: SD-18

KEYED NOTES:

- ① CONCEALED DOOR POSITION SENSOR INCLUDED IN AD-400 KIT
- ② AD-400-CY-70-MS-ATH-PD (BY DIV 28)

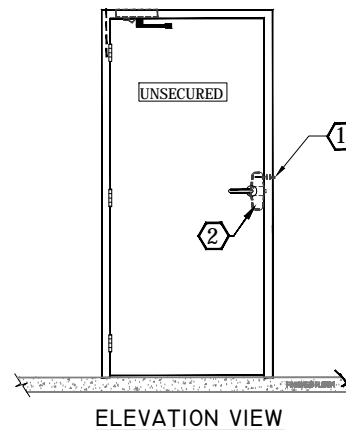
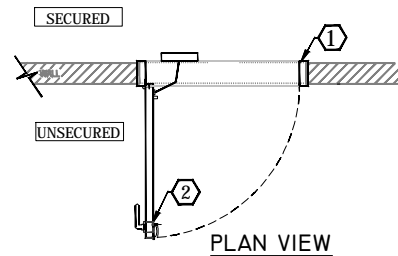

HW-21 Hardware Group No. 21
Not to Scale

HARDWARE GROUPS BASED ON
UMBS 087100 DOOR HARDWARE
STANDARDS 2017 EDITION

GENERAL NOTES
CABLE SCHEDULE

DESIGNATION	DEVICE	CABLE CONFIGURATION
Y1	DPS	4-COND. 22 AWG NO SHIELD
Y2	CR	8-COND. 18 AWG SHIELDED W/DRAIN
Y3	RX	6-COND. 18 AWG SHIELDED NO SHIELD
Y4	EL	4-COND. 18 AWG SHIELDED NO SHIELD
Y	CR-DPS-RX-EL	COMPOSITE CABLE
P	PIM	2-CONDUCTOR 18 AWG 1 PAIR 22 AWG Shielded
P	AD-300	2-CONDUCTOR 18 AWG 1 PAIR 22 AWG Shielded
P	NDE	2-CONDUCTOR 18 AWG 1 PAIR 22 AWG Shielded
AD-WL	AD-400	WIRELESS LOCK

COMPONENT LEGEND	
CR	CARD READER
DPS	DOOR POSITION SWITCH
EX	REQUEST TO EXIT
LX	LATCH BOLT MONITOR
EL	ELECTRIC EXIT DEVICE
ES	ELECTRIC STRIKE
PT	ELECTRIC PASS THROUGH DEVICE
PIM	PIM-16-485
AD-400	AD-400 WIRELESS LOCK
AD-300	AD-300 HARDWIRED LOCK
NDE	NDE WIRELESS LOCK
ES	ELECTRIC HARDWARE POWER SUPPLY
ADA	HANDICAP OPERATOR (TYPICAL)
EP	HANDICAP PUSH PLATE (TYPICAL)

CABLE DESCRIPTION		
Y- WCW COMPOSITE CABLE SPECIFY RISER OR PLENUM WCW Composite Cable PN# Cbord-AC-A-PL		
NON-EXTENDED CABLE		
Y-1	4-Cond. #22 AWG/STRD/NO SHIELD	WCW#444381-PL
Y-2	8-Cond. #18 AWG/STRD/SHLD/w/DRAIN	WCW#002352-PL
Y-3	6-Cond. #18 AWG/STRD/NO SHIELD	WCW#1002391-04-PL
Y-4	4-Cond. #18 AWG/STRD/NO SHIELD	WCW#442380-PL
P	2-COND.#18 AWG 1 PAIR 22 AWG Shielded	WCW-92ELEMPLNTY
X- WCW COMPOSITE CABLE SPECIFY RISER OR PLENUM WCW Composite Cable PN# Cbord-AC-A-EXT-PL		
EXTENDED CABLE		
X-1	4-Cond. #22 AWG/STRD/NO SHIELD	WCW#444381-PL
X-2	8-Cond. #18 AWG/STRD/SHLD/w/DRAIN	WCW#002352-PL
X-3	6-Cond. #18 AWG/STRD/NO SHIELD	WCW#1002391-04-PL
X-4	4-Cond. #18 AWG/STRD/NO SHIELD	WCW#991380-PL
P	2-COND.#18 AWG 1 PAIR 22 AWG Shielded	WCW-92ELEMPLNTY

Project Name and Address
Univ of Miami
Device Elevation
SHOP DWG: SD-19

KEYED NOTES:

- ① 1" CONDUIT TO ACCESSIBLE CEILING FOR PATHWAY AND WIRING TO SECURITY CONTROL LOCATION. (BY DIV 26)
- ② CONCEALED 4" X 4" COVERED JUNCTION BOX LOCATED NEAR DOOR ABOVE CEILING ACCESSIBLE TO SECURE SIDE. (BY DIV 26)
- ③ ALLEGION POWER TRANSFER EPT-10 (BY DIV 08)
- ④ PROVIDE 3/4" CONDUIT, REQUIRED FRAME AND PATHWAY PREPARATION FOR WIREWAY THROUGH DOOR (BY DIV 26)
- ⑤ AD-300-993R-70-MS-ATH-PD (BY DIV 28)
- ⑥ EXIT DEVICE RX-LC-HH-98-EO-SNB (BY DIV 8)

*HURRICANE COMPLIANT OPENING
 *AD TRIM NEEDS TO BE SET TO FAILSAFE OVER 4 STORY OR LOCAL HEIGHT LIMIT FOR STAIRWELLS

HW-22 Hardware Group No. 22
 Not to Scale

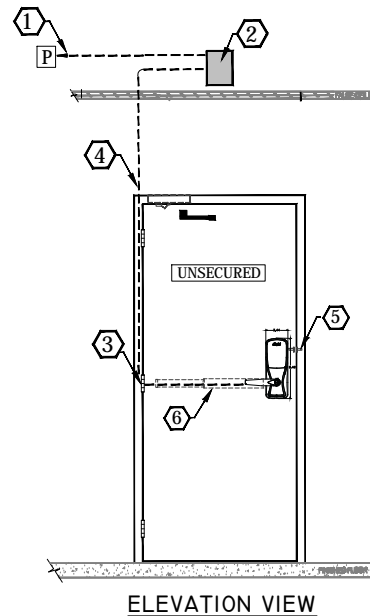
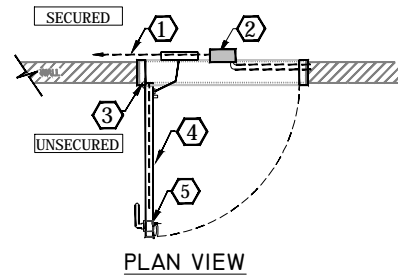

GENERAL NOTES
 CABLE SCHEDULE

DESIGNATION	DEVICE	CABLE CONFIGURATION
Y1	DPS	4-COND. 22 AWG NO SHIELD
Y2	CR	8-COND. 18 AWG SHIELDED W/DRAIN
Y3	RX	6-COND. 18 AWG SHIELDED NO SHIELD
Y4	EL	4-COND. 18 AWG SHIELDED NO SHIELD
Y	CR-DPS-RX-EL	COMPOSITE CABLE
P	PIM	2-CONDUCTOR 18 AWG 1 PAIR 22 AWG Shielded
P	AD-300	2-CONDUCTOR 18 AWG 1 PAIR 22 AWG Shielded
P	NDE	2-CONDUCTOR 18 AWG 1 PAIR 22 AWG Shielded
AD-WL	AD-400	WIRELESS LOCK

COMPONENT LEGEND

CR	CARD READER
DPS	DOOR POSITION SWITCH
RX	REQUEST TO EXIT
EL	LATCH BOLT MONITOR
ES	ELECTRIC EXIT DEVICE
ES	ELECTRIC STRIKE
PT	ELECTRIC PASS THROUGH DEVICE
PIM	PIM-16-485
AD-400	AD-400 WIRELESS LOCK
AD-300	AD-300 HARDWIRED LOCK
NDE	NDE WIRELESS LOCK
ES	ELECTRIC HARDWARE POWER SUPPLY
ADA	HANDICAP OPERATOR (TYPICAL)
PH	HANDICAP PUSH PLATE (TYPICAL)

CABLE DESCRIPTION

Y- WCW COMPOSITE CABLE
 SPECIFY RISER OR PLENUM
 WCW Composite Cable
 PN# Chord-AC-A-PL

NON- EXTENDED CABLE

Y-1	4-Cond. #22 AWG/STRD/NO SHIELD	WCW#444381-PL
Y-2	8-Cond. #18 AWG/STRD/SHLD/w/DRAIN	WCW#002352-PL
Y-3	6-Cond. #18 AWG/STRD/NO SHIELD	WCW#U002391-04-PL
Y-4	4-Cond. #18 AWG/STRD/NO SHIELD	WCW#442380-PL
P	2-COND.#18 AWG 1 PAIR 22 AWG Shielded	WCW-92ELEMPLNTY

X- WCW COMPOSITE CABLE
 SPECIFY RISER OR PLENUM
 WCW Composite Cable
 PN# Chord-AC-A-EXT-PL

EXTENDED CABLE

X-1	4-Cond. #22 AWG/STRD/NO SHIELD	WCW#444381-PL
X-2	8-Cond. #18 AWG/STRD/SHLD/w/DRAIN	WCW#002352-PL
X-3	6-Cond. #18 AWG/STRD/NO SHIELD	WCW#U002391-04-PL
X-4	4-Cond. #16 AWG/STRD/NO SHIELD	WCW#991380-PL
P	2-COND.#18 AWG 1 PAIR 22 AWG Shielded	WCW-92ELEMPLNTY

Project Name and Address

Univ of Miami
 Device Elevation
 SHOP DWG: SD-20

HARDWARE GROUPS BASED ON
 UMBS 087100 DOOR HARDWARE
 STANDARDS 2017 EDITION

KEYED NOTES:

- ① 1" CONDUIT TO ACCESSIBLE CEILING FOR PATHWAY AND WIRING TO SECURITY CONTROL LOCATION. (BY DIV 26)
- ② CONCEALED 4" X 4" COVERED JUNCTION BOX LOCATED NEAR DOOR ABOVE CEILING ACCESSIBLE TO SECURE SIDE. (BY DIV 26)
- ③ ALLEGION POWER TRANSFER EPT-10 (BY DIV 08)
- ④ PROVIDE $\frac{3}{4}$ " CONDUIT, REQUIRED FRAME AND PATHWAY PREPARATION FOR WIREWAY THROUGH DOOR (BY DIV 26)
- ⑤ AD-300-993R-70-MS-ATH-PD (BY DIV 28)
- ⑥ EXIT DEVICE RX-LC-HH-98-EO-SNB (BY DIV 8)

*HURRICANE COMPLIANT OPENING
 *AD TRIM NEEDS TO BE SET TO FAILSAFE OVER 4 STORY OR LOCAL HEIGHT LIMIT FOR STAIRWELLS

HW-23 Hardware Group No. 23
 Not to Scale

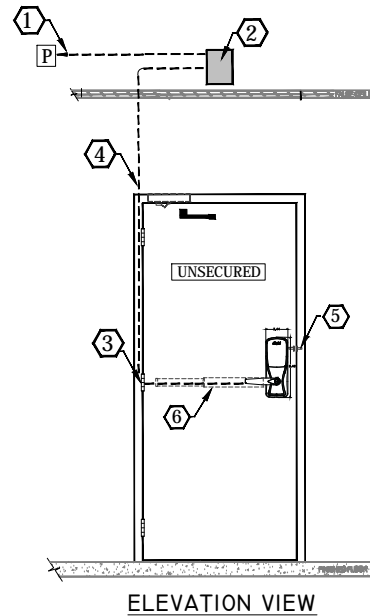
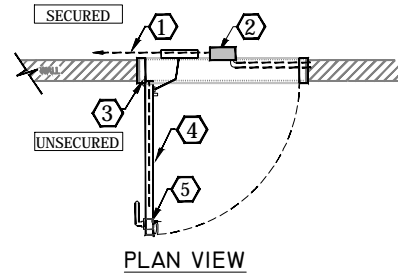

GENERAL NOTES
CABLE SCHEDULE

DESIGNATION	DEVICE	CABLE CONFIGURATION
Y1	DPS	4-COND. 22 AWG NO SHIELD
Y2	CR	8-COND. 18 AWG SHIELDED W/DRAIN
Y3	RX	6-COND. 18 AWG SHIELDED NO SHIELD
Y4	EL	4-COND. 18 AWG SHIELDED NO SHIELD
Y	CR-DPS-RX-EL	COMPOSITE CABLE
P	PIM	2-CONDUCTOR 18 AWG 1 PAIR 22 AWG Shielded
P	AD-300	2-CONDUCTOR 18 AWG 1 PAIR 22 AWG Shielded
P	NDE	2-CONDUCTOR 18 AWG 1 PAIR 22 AWG Shielded
AD-WL	AD-400	WIRELESS LOCK

COMPONENT LEGEND

	CARD READER
	DOOR POSITION SWITCH
	REQUEST TO EXIT
	LATCH BOLT MONITOR
	ELECTRIC EXIT DEVICE
	ELECTRIC STRIKE
	ELECTRIC PASS THROUGH DEVICE
	PIM-16-485
	AD-400 WIRELESS LOCK
	AD-300 HARDWIRED LOCK
	NDE WIRELESS LOCK
	ELECTRIC HARDWARE POWER SUPPLY
	HANDICAP OPERATOR (TYPICAL)
	HANDICAP PUSH PLATE (TYPICAL)

CABLE DESCRIPTION

Y- WCW COMPOSITE CABLE
 SPECIFY RISER OR PLENUM
 WCW Composite Cable
 PN# Chord-AC-A-PL

NON-EXTENDED CABLE

Y-1	4-Cond. #22 AWG/STRD/NO SHIELD	WCW#444381-PL
Y-2	8-Cond. #18 AWG/STRD/SHLD/w/DRAIN	WCW#002352-PL
Y-3	6-Cond. #18 AWG/STRD/NO SHIELD	WCW#U002391-04-PL
Y-4	4-Cond. #18 AWG/STRD/NO SHIELD	WCW#442380-PL
P	2-COND.#18 AWG 1 PAIR 22 AWG Shielded	WCW-92ELEMPLNTY

X- WCW COMPOSITE CABLE
 SPECIFY RISER OR PLENUM
 WCW Composite Cable
 PN# Chord-AC-A-EXT-PL

EXTENDED CABLE

X-1	4-Cond. #22 AWG/STRD/NO SHIELD	WCW#444381-PL
X-2	8-Cond. #18 AWG/STRD/SHLD/w/DRAIN	WCW#002352-PL
X-3	6-Cond. #18 AWG/STRD/NO SHIELD	WCW#U002391-04-PL
X-4	4-Cond. #18 AWG/STRD/NO SHIELD	WCW#991380-PL
P	2-COND.#18 AWG 1 PAIR 22 AWG Shielded	WCW-92ELEMPLNTY

Project Name and Address

Univ of Miami
 Device Elevation
 SHOP DWG: SD-21

HARDWARE GROUPS BASED ON
 UMBS 087100 DOOR HARDWARE
 STANDARDS 2017 EDITION

KEYED NOTES:

- ① 1" CONDUIT TO ACCESSIBLE CEILING FOR PATHWAY AND WIRING TO SECURITY CONTROL LOCATION. (BY DIV 26)
- ② CONCEALED 4" X 4" COVERED JUNCTION BOX LOCATED NEAR DOOR ABOVE CEILING ACCESSIBLE TO SECURE SIDE. (BY DIV 26)
- ③ ALLEGION POWER TRANSFER EPT-10 (BY DIV 08)
- ④ PROVIDE $\frac{3}{4}$ " CONDUIT, REQUIRED FRAME AND PATHWAY PREPARATION FOR WIREWAY THROUGH DOOR (BY DIV 26)
- ⑤ AD-300-993R-70-MS-ATH-PD (BY DIV 28)
- ⑥ EXIT DEVICE RX-LC-HH-98-EO-SNB (BY DIV 8)

*HURRICANE COMPLIANT OPENING
 *AD TRIM NEEDS TO BE SET TO FAILSAFE OVER 4 STORY OR LOCAL HEIGHT LIMIT FOR STAIRWELLS

HW-25 Hardware Group No. 25
 Not to Scale

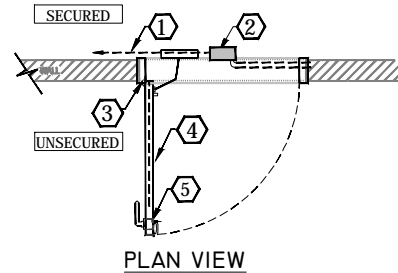

PLAN VIEW

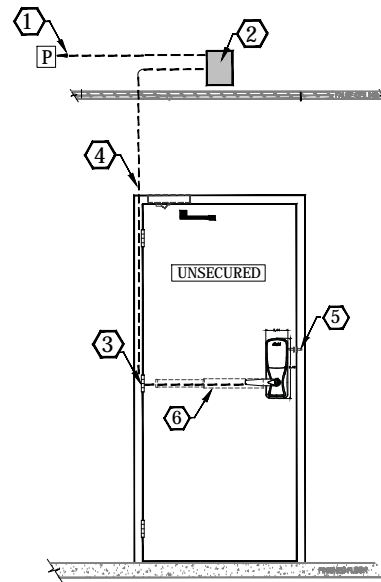

ELEVATION VIEW

HARDWARE GROUPS BASED ON UMBS 087100 DOOR HARDWARE STANDARDS 2017 EDITION

GENERAL NOTES
 CABLE SCHEDULE

DESIGNATION	DEVICE	CABLE CONFIGURATION
Y1	DPS	4-COND. 22 AWG NO SHIELD
Y2	CR	8-COND. 18 AWG SHIELDED W/DRAIN
Y3	RX	6-COND. 18 AWG SHIELDED NO SHIELD
Y4	EL	4-COND. 18 AWG SHIELDED NO SHIELD
Y	CR- DPS- RX- EL	COMPOSITE CABLE
P	PIM	2-CONDUCTOR 18 AWG 1 PAIR 22 AWG Shielded
P	AD-300	2-CONDUCTOR 18 AWG 1 PAIR 22 AWG Shielded
P	NDE	2-CONDUCTOR 18 AWG 1 PAIR 22 AWG Shielded
AD-WL	AD-400	WIRELESS LOCK

COMPONENT LEGEND

CR	CARD READER
DPS	DOOR POSITION SWITCH
RX	REQUEST TO EXIT
EL	LATCH BOLT MONITOR
ES	ELECTRIC EXIT DEVICE
ES	ELECTRIC STRIKE
PT	ELECTRIC PASS THROUGH DEVICE
PIM	PIM-16-485
AD-400	AD-400 WIRELESS LOCK
AD-300	AD-300 HARDWIRED LOCK
NDE	NDE WIRELESS LOCK
ES	ELECTRIC HARDWARE POWER SUPPLY
ADA	HANDICAP OPERATOR (TYPICAL)
PH	HANDICAP PUSH PLATE (TYPICAL)

CABLE DESCRIPTION

Y- WCW COMPOSITE CABLE
 SPECIFY RISER OR PLENUM
 WCW Composite Cable
 PN# Chord-AC-A-PL

NON- EXTENDED CABLE

Y-1	4-Cond. #22 AWG/STRD/NO SHIELD	WCW#444381-PL
Y-2	8-Cond. #18 AWG/STRD/SHLD/w/DRAIN	WCW#002352-PL
Y-3	6-Cond. #18 AWG/STRD/NO SHIELD	WCW#U002391-04-PL
Y-4	4-Cond. #18 AWG/STRD/NO SHIELD	WCW#442380-PL
P	2-COND. #18 AWG 1 PAIR 22 AWG Shielded	WCW-92ELEMPLY

X- WCW COMPOSITE CABLE
 SPECIFY RISER OR PLENUM
 WCW Composite Cable
 PN# Chord-AC-A-EXT-PL

EXTENDED CABLE

X-1	4-Cond. #22 AWG/STRD/NO SHIELD	WCW#444381-PL
X-2	8-Cond. #18 AWG/STRD/SHLD/w/DRAIN	WCW#002352-PL
X-3	6-Cond. #18 AWG/STRD/NO SHIELD	WCW#U002391-04-PL
X-4	4-Cond. #18 AWG/STRD/NO SHIELD	WCW#991380-PL
P	2-COND. #18 AWG 1 PAIR 22 AWG Shielded	WCW-92ELEMPLY

Project Name and Address
Univ of Miami
Device Elevation
SHOP DWG: SD-22

KEYED NOTES:

- ① 1" CONDUIT TO ACCESSIBLE CEILING FOR PATHWAY AND WIRING TO SECURITY CONTROL LOCATION. (BY DIV 26)
- ② CONCEALED 6" X 8" X 3" COVERED JUNCTION BOX LOCATED NEAR DOOR ABOVE CEILING ACCESSIBLE TO SECURE SIDE. (BY DIV 26)
- ③ CONCEALED DOOR POSITION SENSOR PROVIDE 3/4" CONDUIT AND REQUIRED FRAME AND PATHWAY PREPARATION (BY DIV 26)
- ④ CONCEALED 1" DOOR POSITION SENSOR 679-05HM (BY DIV 28)
- ⑤ ALLEGION POWER TRANSFER EPT-10 (BY DIV 08)
- ⑥ PROVIDE 3/4" CONDUIT, REQUIRED FRAME AND PATHWAY PREPARATION FOR WIREWAY THROUGH DOOR (BY DIV 26)
- ⑦ EXIT DEVICE: RX-QEL+-HH-9847-EO-SNB CONCEALED VERTICAL RODS (BY DIV 28)
- ⑧ MOUNT SINGE GANG JUNCTION BOX AND CONDUIT FOR CARD READER (BY DIV 26)
- ⑨ MOUNT MTMS15 CARD READER ON UNSECURE SIDE 42" AFF AND 6" OPTIMUM FROM DOOR. (BY DIV 28)
- ⑩ DOOR HARDWARE POWER SUPPLY. PS902 900-2RS (BY DIV 28)
- ⑪ 120 VAC CIRCUIT (DIV 26).
- ⑫ LCN-9553 REG2 MS ADA OPERATOR (BY DIV 08)
- ⑬ PROVIDE 3/4" CONDUIT AND PATHWAY PREPARATION FOR WIREWAY. (BY DIV 26)
- ⑭ LCN:OPERATOR ACTUATOR, WALL 8310-853 (BY DIV 08)
- ⑮ MOUNT LCN-ACUTATOR ON SECURE SIDE 42" AFF (BY DIV 08)

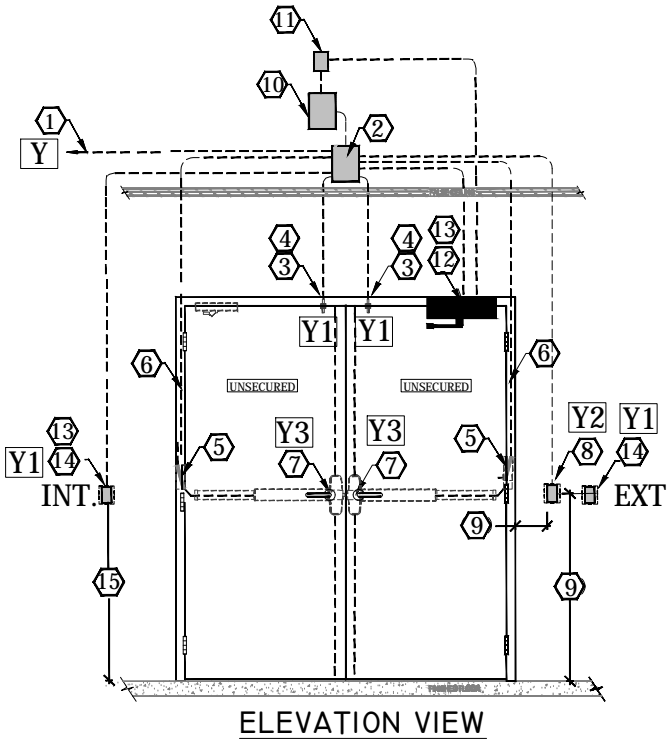

1) During business hours both outside and inside actuators are active (button pushed and doors open)
 2) After hours (time zones end), inside button always active 24/7. However outside button is inactive. Card has to be swiped in order to activate outside button. Once button is pushed door hardware will retract simultaneously with door opening. If button is not pushed after card is swiped door can be pulled open.

**GENERAL NOTES
CABLE SCHEDULE**

DESIGNATION	DEVICE	CABLE CONFIGURATION
Y1	DPS	4-COND. 22 AWG NO SHIELD
Y2	CR	8-COND. 18 AWG SHIELDED W/DRAIN
Y3	RX	6-COND. 18 AWG SHIELDED NO SHIELD
Y4	EL	4-COND. 18 AWG SHIELDED NO SHIELD
Y	CR-DPS- RX-EL	COMPOSITE CABLE
P	PIM	2-CONDUCTOR 18 AWG 1 PAIR 22 AWG Shielded
P	AD-300	2-CONDUCTOR 18 AWG 1 PAIR 22 AWG Shielded
P	NDE	2-CONDUCTOR 18 AWG 1 PAIR 22 AWG Shielded
AD-WL	AD-400	WIRELESS LOCK

COMPONENT LEGEND

CR	CARD READER
DPS	DOOR POSITION SWITCH
RX	REQUEST TO EXIT
LN	LATCH BOLT MONITOR
EL	ELECTRIC EXIT DEVICE
ES	ELECTRIC STRIKE
PT	ELECTRIC PASS THROUGH DEVICE
PIM	PIM-16-485
AD-400	AD-400 WIRELESS LOCK
AD-300	AD-300 HARDWIRED LOCK
NDE	NDE WIRELESS LOCK
ES	ELECTRIC HARDWARE POWER SUPPLY
ADA	HANDICAP OPERATOR (TYPICAL)
EP	HANDICAP PUSH PLATE (TYPICAL)

CABLE DESCRIPTION

Y- WCW COMPOSITE CABLE
 SPECIFY RISER OR PLENUM
 WCW Composite Cable
 PN# Chord-AC-A-PL

NON-EXTENDED CABLE

Y-1	4-Cond. #22 AWG/STRD/NO SHIELD	WCW#444381-PL
Y-2	8-Cond. #18 AWG/STRD/SHLD W/DRAIN	WCW#002352-PL
Y-3	6-Cond. #18 AWG/STRD/NO SHIELD	WCW#UD02391-04-PL
Y-4	4-Cond. #18 AWG/STRD/NO SHIELD	WCW#442380-PL
P	2-COND. #18 AWG 1 PAIR 22 AWG Shielded	WCW-92ELEMPLTY

X- WCW COMPOSITE CABLE
 SPECIFY RISER OR PLENUM
 WCW Composite Cable
 PN# Chord-AC-A-EXT-PL

EXTENDED CABLE

X-1	4-Cond. #22 AWG/STRD/NO SHIELD	WCW#444381-PL
X-2	8-Cond. #18 AWG/STRD/SHLD W/DRAIN	WCW#002352-PL
X-3	6-Cond. #18 AWG/STRD/NO SHIELD	WCW#UD02391-04-PL
X-4	4-Cond. #18 AWG/STRD/NO SHIELD	WCW#991380-PL
P	2-COND. #18 AWG 1 PAIR 22 AWG Shielded	WCW-92ELEMPLTY

Project Name and Address

**Univ of Miami
Device Elevation**

SHOP DWG: DD-4



Hardware Group No. 26

Not to Scale

HARDWARE GROUPS BASED ON
 UMBS 087100 DOOR HARDWARE
 STANDARDS 2017 EDITION

KEYED NOTES:

- ① 1" CONDUIT TO ACCESSIBLE CEILING FOR PATHWAY AND WIRING TO SECURITY CONTROL LOCATION. (BY DIV 26)
- ② CONCEALED 6" X 8" X 3" COVERED JUNCTION BOX LOCATED NEAR DOOR ABOVE CEILING ACCESSIBLE TO SECURE SIDE. (BY DIV 26)
- ③ CONCEALED DOOR POSITION SENSOR PROVIDE 3/4" CONDUIT AND REQUIRED FRAME AND PATHWAY PREPARATION (BY DIV 26)
- ④ CONCEALED 1" DOOR POSITION SENSOR 679-05HM (BY DIV 28)
- ⑤ ALLEGION POWER TRANSFER EPT-10 (BY DIV 08)
- ⑥ PROVIDE 3/4" CONDUIT, REQUIRED FRAME AND PATHWAY PREPARATION FOR WIREWAY THROUGH DOOR (BY DIV 26)
- ⑦ EXIT DEVICE: RX-QEL+-HH-9847-EO-SNB CONCEALED VERTICAL RODS (BY DIV 28)
- ⑧ MOUNT SINGE GANG JUNCTION BOX AND CONDUIT FOR CARD READER (BY DIV 26)
- ⑨ MOUNT MTMS15 CARD READER ON UNSECURE SIDE 42" AFF AND 6" OPTIMUM FROM DOOR. (BY DIV 28)
- ⑩ DOOR HARDWARE POWER SUPPLY. PS902 900-2RS (BY DIV 28)
- ⑪ 120 VAC CIRCUIT (DIV 26).
- ⑫ LCN-9553 REG2 MS ADA OPERATOR (BY DIV 08)
- ⑬ PROVIDE 3/4" CONDUIT AND PATHWAY PREPARATION FOR WIREWAY. (BY DIV 26)
- ⑭ LCN:OPERATOR ACTUATOR, WALL 8310-853 (BY DIV 08)
- ⑮ MOUNT LCN-ACUTATOR ON SECURE SIDE 42" AFF (BY DIV 08)

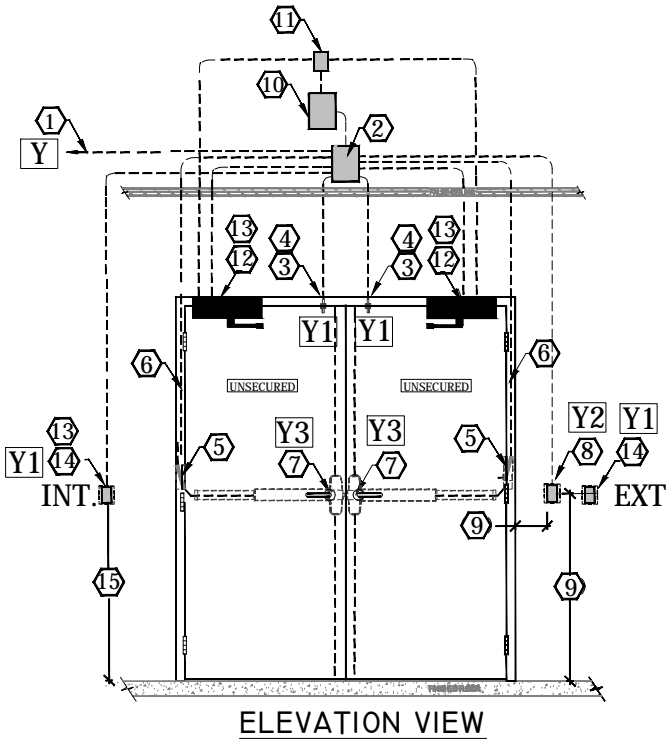

1) During business hours both outside and inside actuators are active (button pushed and doors open)
 2) After hours (time zones end), inside button always active 24/7. However outside button is inactive. Card has to be swiped in order to activate outside button. Once button is pushed door hardware will retract simultaneously with door opening. If button is not pushed after card is swiped door can be pulled open.

HW-26 Hardware Group No. 26
 Not to Scale

HARDWARE GROUPS BASED ON
 UMBS 087100 DOOR HARDWARE
 STANDARDS 2017 EDITION

GENERAL NOTES CABLE SCHEDULE		
DESIGNATION	DEVICE	CABLE CONFIGURATION
Y1	DPS	4-COND. 22 AWG NO SHIELD
Y2	CR	8-COND. 18 AWG SHIELDED W/DRAIN
Y3	RX	6-COND. 18 AWG SHIELDED NO SHIELD
Y4	EL	4-COND. 18 AWG SHIELDED NO SHIELD
Y	CR-DPS- RX-EL	COMPOSITE CABLE
P	PIM	2-CONDUCTOR 18 AWG 1 PAIR 22 AWG Shielded
P	AD-300	2-CONDUCTOR 18 AWG 1 PAIR 22 AWG Shielded
P	NDE	2-CONDUCTOR 18 AWG 1 PAIR 22 AWG Shielded
AD-WL	AD-400	WIRELESS LOCK
COMPONENT LEGEND		
CR	CARD READER	
DPS	DOOR POSITION SWITCH	
RX	REQUEST TO EXIT	
LN	LATCH BOLT MONITOR	
EL	ELECTRIC EXIT DEVICE	
ES	ELECTRIC STRIKE	
PT	ELECTRIC PASS THROUGH DEVICE	
PIM	PIM-16-485	
AD-400	AD-400 WIRELESS LOCK	
AD-300	AD-300 HARDWIRED LOCK	
NDE	NDE WIRELESS LOCK	
ES	ELECTRIC HARDWARE POWER SUPPLY	
ADA	HANDICAP OPERATOR (TYPICAL)	
PP	HANDICAP PUSH PLATE (TYPICAL)	
CABLE DESCRIPTION		
Y- WCW COMPOSITE CABLE SPECIFY RISER OR PLENUM WCW Composite Cable PN# Chord-AC-A-PL		
NON-EXTENDED CABLE		
Y-1	4-Cond. #22 AWG/STRD/NO SHIELD	WCW#444381-PL
Y-2	8-Cond. #18 AWG/STRD/SHLD W/DRAIN	WCW#002352-PL
Y-3	6-Cond. #18 AWG/STRD/NO SHIELD	WCW#UD02391-04-PL
Y-4	4-Cond. #18 AWG/STRD/NO SHIELD	WCW#442380-PL
P	2-COND. #18 AWG 1 PAIR 22 AWG Shielded	WCW-92ELEMPLTY
X- WCW COMPOSITE CABLE SPECIFY RISER OR PLENUM WCW Composite Cable PN# Chord-AC-A-EXT-PL		
EXTENDED CABLE		
X-1	4-Cond. #22 AWG/STRD/NO SHIELD	WCW#444381-PL
X-2	8-Cond. #18 AWG/STRD/SHLD W/DRAIN	WCW#002352-PL
X-3	6-Cond. #18 AWG/STRD/NO SHIELD	WCW#UD02391-04-PL
X-4	4-Cond. #18 AWG/STRD/NO SHIELD	WCW#991380-PL
P	2-COND. #18 AWG 1 PAIR 22 AWG Shielded	WCW-92ELEMPLTY

Project Name and Address
Univ of Miami
Device Elevation
SHOP DWG: DD-3

KEYED NOTES:

- ① 1" CONDUIT TO ACCESSIBLE CEILING FOR PATHWAY AND WIRING TO SECURITY CONTROL LOCATION. (BY DIV 26)
- ② CONCEALED 6" X 8" X 3" COVERED JUNCTION BOX LOCATED NEAR DOOR ABOVE CEILING ACCESSIBLE TO SECURE SIDE. (BY DIV 26)
- ③ CONCEALED DOOR POSITION SENSOR PROVIDE 3/4" CONDUIT AND REQUIRED FRAME AND PATHWAY PREPARATION (BY DIV 26)
- ④ CONCEALED 1" DOOR POSITION SENSOR 679-05HM (BY DIV 28)
- ⑤ ALLEGION POWER TRANSFER EPT-10 (BY DIV 08)
- ⑥ PROVIDE 3/4" CONDUIT, REQUIRED FRAME AND PATHWAY PREPARATION FOR WIREWAY THROUGH DOOR (BY DIV 26)
- ⑦ EXIT DEVICE: RX-QEL+-HH-9847-EO-SNB CONCEALED VERTICAL RODS (BY DIV 28)
- ⑧ MOUNT SINGE GANG JUNCTION BOX AND CONDUIT FOR CARD READER (BY DIV 26)
- ⑨ MOUNT MTMS15 CARD READER ON UNSECURE SIDE 42" AFF AND 6" OPTIMUM FROM DOOR. (BY DIV 28)
- ⑩ DOOR HARDWARE POWER SUPPLY. PS902 900-2RS (BY DIV 28)
- ⑪ 120 VAC CIRCUIT (DIV 26).
- ⑫ LCN-9553 REG2 MS ADA OPERATOR (BY DIV 08)
- ⑬ PROVIDE 3/4" CONDUIT AND PATHWAY PREPARATION FOR WIREWAY. (BY DIV 26)
- ⑭ LCN:OPERATOR ACTUATOR, WALL 8310-853 (BY DIV 08)
- ⑮ MOUNT LCN-ACUTATOR ON SECURE SIDE 42" AFF (BY DIV 08)

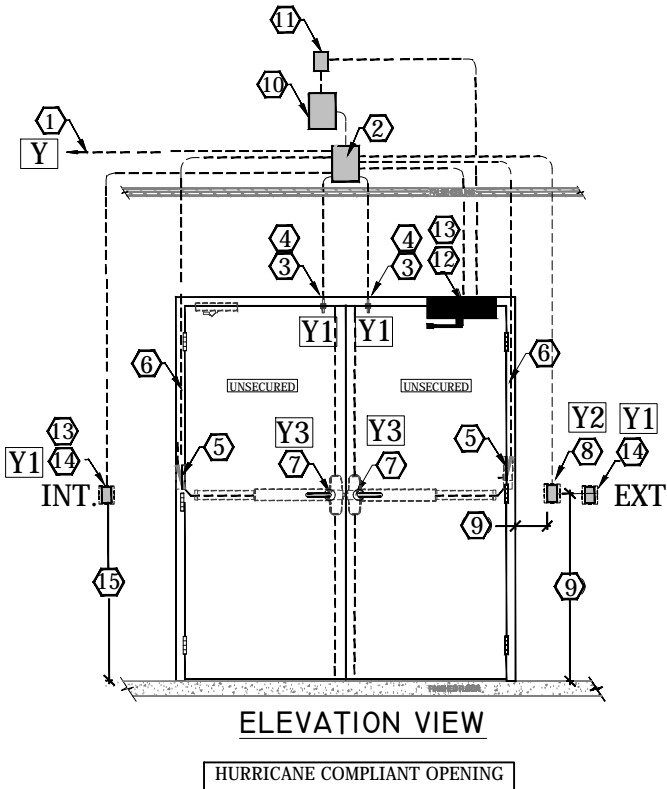

1) During business hours both outside and inside actuators are active (button pushed and doors open)
 2) After hours (time zones end), inside button always active 24/7. However outside button is inactive. Card has to be swiped in order to activate outside button. Once button is pushed door hardware will retract simultaneously with door opening. If button is not pushed after card is swiped door can be pulled open.

HW-26 Hardware Group No. 26
 Not to Scale

HARDWARE GROUPS BASED ON UMBS 087100 DOOR HARDWARE STANDARDS 2017 EDITION

GENERAL NOTES CABLE SCHEDULE		
DESIGNATION	DEVICE	CABLE CONFIGURATION
Y1	DPS	4-COND. 22 AWG NO SHIELD
Y2	CR	8-COND. 18 AWG SHIELDED W/DRAIN
Y3	RX	6-COND. 18 AWG SHIELDED NO SHIELD
Y4	EL	4-COND. 18 AWG SHIELDED NO SHIELD
Y	CR-DPS- RX-EL	COMPOSITE CABLE
P	PIM	2-CONDUCTOR 18 AWG 1 PAIR 22 AWG Shielded
P	AD-300	2-CONDUCTOR 18 AWG 1 PAIR 22 AWG Shielded
P	NDE	2-CONDUCTOR 18 AWG 1 PAIR 22 AWG Shielded
AD-WL	AD-400	WIRELESS LOCK
COMPONENT LEGEND		
CR	CARD READER	
DPS	DOOR POSITION SWITCH	
RX	REQUEST TO EXIT	
LN	LATCH BOLT MONITOR	
EL	ELECTRIC EXIT DEVICE	
ES	ELECTRIC STRIKE	
PT	ELECTRIC PASS THROUGH DEVICE	
PIM	PIM-16-485	
AD-400	AD-400 WIRELESS LOCK	
AD-300	AD-300 HARDWIRED LOCK	
NDE	NDE WIRELESS LOCK	
ES	ELECTRIC HARDWARE POWER SUPPLY	
ADA	HANDICAP OPERATOR (TYPICAL)	
PP	HANDICAP PUSH PLATE (TYPICAL)	
CABLE DESCRIPTION		
Y- WCW COMPOSITE CABLE SPECIFY RISER OR PLENUM WCW Composite Cable PN# Chord-AC-A-PL		
NON-EXTENDED CABLE		
Y-1	4-Cond. #22 AWG/STRD/NO SHIELD	WCW#444381-PL
Y-2	8-Cond. #18 AWG/STRD/SHLD W/DRAIN	WCW#002352-PL
Y-3	6-Cond. #18 AWG/STRD/NO SHIELD	WCW#UD02391-04-PL
Y-4	4-Cond. #18 AWG/STRD/NO SHIELD	WCW#442380-PL
P	2-COND. #18 AWG 1 PAIR 22 AWG Shielded	WCW-92ELEMPLTY
X- WCW COMPOSITE CABLE SPECIFY RISER OR PLENUM WCW Composite Cable PN# Chord-AC-A-EXT-PL		
EXTENDED CABLE		
X-1	4-Cond. #22 AWG/STRD/NO SHIELD	WCW#444381-PL
X-2	8-Cond. #18 AWG/STRD/SHLD W/DRAIN	WCW#002352-PL
X-3	6-Cond. #18 AWG/STRD/NO SHIELD	WCW#UD02391-04-PL
X-4	4-Cond. #18 AWG/STRD/NO SHIELD	WCW#991380-PL
P	2-COND. #18 AWG 1 PAIR 22 AWG Shielded	WCW-92ELEMPLTY

Project Name and Address
Univ of Miami
Device Elevation
SHOP DWG: DD-4

KEYED NOTES:

- ① 1" CONDUIT TO ACCESSIBLE CEILING FOR PATHWAY AND WIRING TO SECURITY CONTROL LOCATION. (BY DIV 26)
- ② CONCEALED 6" X 8" X 3" COVERED JUNCTION BOX LOCATED NEAR DOOR ABOVE CEILING ACCESSIBLE TO SECURE SIDE. (BY DIV 26)
- ③ CONCEALED DOOR POSITION SENSOR PROVIDE $\frac{3}{4}$ " CONDUIT AND REQUIRED FRAME AND PATHWAY PREPARATION (BY DIV 26)
- ④ CONCEALED 1" DOOR POSITION SENSOR 679-05HM (BY DIV 28)
- ⑤ ALLEGION POWER TRANSFER EPT-10 (BY DIV 08)
- ⑥ PROVIDE $\frac{3}{4}$ " CONDUIT, REQUIRED FRAME AND PATHWAY PREPARATION FOR WIREWAY THROUGH DOOR (BY DIV 26)
- ⑦ EXIT DEVICE: RX-QEL+-HH-9847-EO-SNB CONCEALED VERTICAL RODS (BY DIV 28)
- ⑧ MOUNT SINGE GANG JUNCTION BOX AND CONDUIT FOR CARD READER (BY DIV 26)
- ⑨ MOUNT MTMS15 CARD READER ON UNSECURE SIDE 42" AFF AND 6" OPTIMUM FROM DOOR. (BY DIV 28)
- ⑩ DOOR HARDWARE POWER SUPPLY. PS902 900-2RS (BY DIV 28)
- ⑪ 120 VAC CIRCUIT (DIV 26).

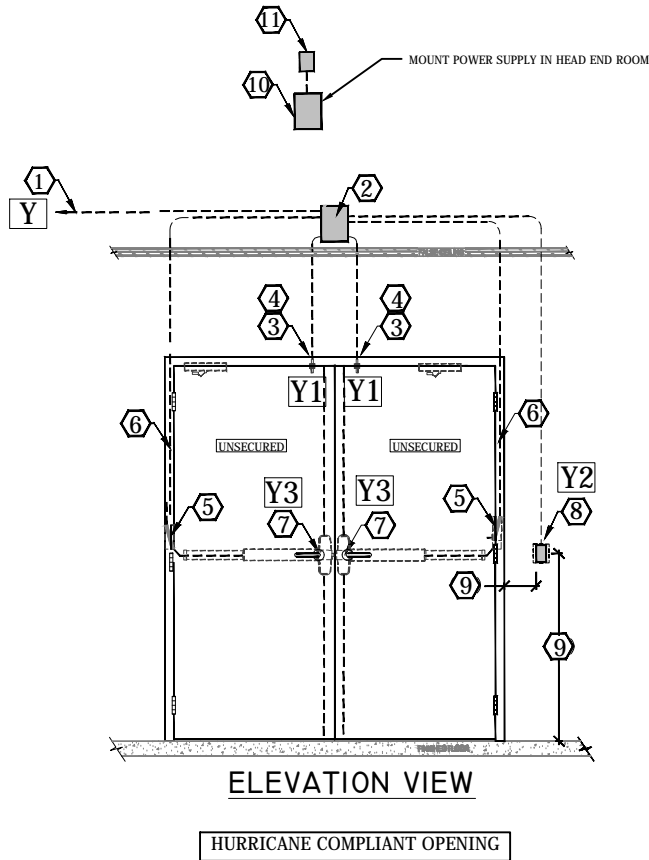

**GENERAL NOTES
CABLE SCHEDULE**

DESIGNATION	DEVICE	CABLE CONFIGURATION
Y1	DPS	4-COND. 22 AWG NO SHIELD
Y2	CR	8-COND. 18 AWG SHIELDED W/DRAIN
Y3	RX	6-COND. 18 AWG SHIELDED NO SHIELD
Y4	EL	4-COND. 18 AWG SHIELDED NO SHIELD
Y	CR-DPS- RX-EL	COMPOSITE CABLE
P	PIM	2-CONDUCTOR 18 AWG 1 PAIR 22 AWG Shielded
P	AD-300	2-CONDUCTOR 18 AWG 1 PAIR 22 AWG Shielded
P	NDE	2-CONDUCTOR 18 AWG 1 PAIR 22 AWG Shielded
AD-WL	AD-400	WIRELESS LOCK

COMPONENT LEGEND	
CR	CARD READER
DPS	DOOR POSITION SWITCH
EX	REQUEST TO EXIT
LX	LATCH BOLT MONITOR
EL	ELECTRIC EXIT DEVICE
ES	ELECTRIC STRIKE
PT	ELECTRIC PASS THROUGH DEVICE
PIM	PIM-16-485
AD-400	AD-400 WIRELESS LOCK
AD-300	AD-300 HARDWIRED LOCK
NDE	NDE WIRELESS LOCK
ES	ELECTRIC HARDWARE POWER SUPPLY
ADA	HANDICAP OPERATOR (TYPICAL)
PP	HANDICAP PUSH PLATE (TYPICAL)

CABLE DESCRIPTION	
Y- WCW COMPOSITE CABLE SPECIFY RISER OR PLENUM WCW Composite Cable PN# Chord-AC-A-PL	
NON-EXTENDED CABLE	
Y-1	4-Cond. #22 AWG/STRD/NO SHIELD WCW#444381-PL
Y-2	8-Cond. #18 AWG/STRD/SHLD W/DRAIN WCW#002352-PL
Y-3	6-Cond. #18 AWG/STRD/NO SHIELD WCW#UD02391-04-PL
Y-4	4-Cond. #18 AWG/STRD/NO SHIELD WCW#442380-PL
P	2-COND. #18 AWG 1 PAIR 22 AWG Shielded WCW-92ELEMPLTY
X- WCW COMPOSITE CABLE SPECIFY RISER OR PLENUM WCW Composite Cable PN# Chord-AC-A-EXT-PL	
EXTENDED CABLE	
X-1	4-Cond. #22 AWG/STRD/NO SHIELD WCW#444381-PL
X-2	8-Cond. #18 AWG/STRD/SHLD W/DRAIN WCW #002352-PL
X-3	6-Cond. #18 AWG/STRD/NO SHIELD WCW#UD02391-04-PL
X-4	4-Cond. #16 AWG/STRD/NO SHIELD WCW#991380-PL
P	2-COND. #18 AWG 1 PAIR 22 AWG Shielded WCW-92ELEMPLTY

HW-27 **Hardware Group No. 27**
Not to Scale

HARDWARE GROUPS BASED ON
UMBS 087100 DOOR HARDWARE
STANDARDS 2017 EDITION

Project Name and Address
**Univ of Miami
Device Elevation**
SHOP DWG: DD-5

KEYED NOTES:

- ① 1" CONDUIT TO ACCESSIBLE CEILING FOR PATHWAY AND WIRING TO SECURITY CONTROL LOCATION. (BY DIV 26)
- ② CONCEALED 6" X 8" X 3" COVERED JUNCTION BOX LOCATED NEAR DOOR ABOVE CEILING ACCESSIBLE TO SECURE SIDE. (BY DIV 26)
- ③ CONCEALED DOOR POSITION SENSOR PROVIDE 3/4" CONDUIT AND REQUIRED FRAME AND PATHWAY PREPARATION (BY DIV 26)
- ④ CONCEALED 1" DOOR POSITION SENSOR 679-05HM (BY DIV 28)
- ⑤ ALLEGION POWER TRANSFER EPT-10 (BY DIV 08)
- ⑥ PROVIDE 3/4" CONDUIT, REQUIRED FRAME AND PATHWAY PREPARATION FOR WIREWAY THROUGH DOOR (BY DIV 26)
- ⑦ EXIT DEVICE: RX-QEL+-HH-9847-EO-SNB CONCEALED VERTICAL RODS (BY DIV 28)
- ⑧ MOUNT SINGE GANG JUNCTION BOX AND CONDUIT FOR CARD READER (BY DIV 26)
- ⑨ MOUNT MTMS15 CARD READER ON UNSECURE SIDE 42" AFF AND 6" OPTIMUM FROM DOOR. (BY DIV 28)
- ⑩ DOOR HARDWARE POWER SUPPLY. PS902 900-2RS (BY DIV 28)
- ⑪ 120 VAC CIRCUIT (DIV 26).
- ⑫ LCN-9553 REG2 MS ADA OPERATOR (BY DIV 08)
- ⑬ PROVIDE 3/4" CONDUIT AND PATHWAY PREPARATION FOR WIREWAY. (BY DIV 26)
- ⑭ LCN:OPERATOR ACTUATOR, WALL 8310-853 (BY DIV 08)
- ⑮ MOUNT LCN-ACUTATOR ON SECURE SIDE 42" AFF (BY DIV 08)

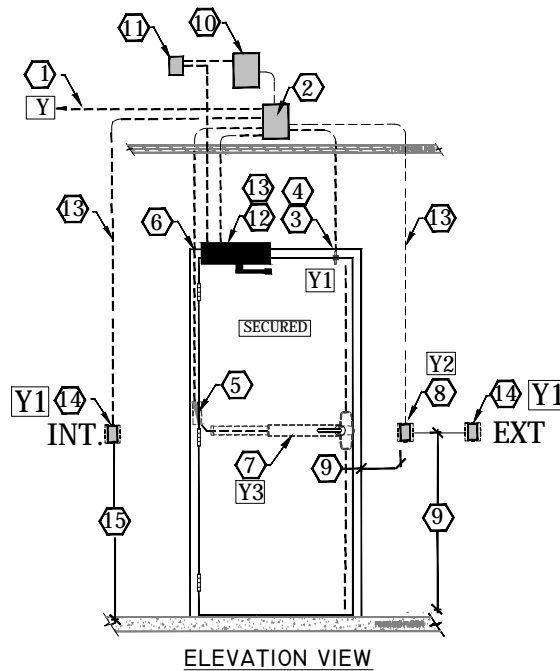

ELEVATION VIEW

HURRICANE COMPLIANT OPENING

1) During business hours both outside and inside actuators are active (button pushed and doors open)
 2) After hours (time zones end), inside button always active 24/7. However outside button is inactive. Card has to be swiped in order to activate outside button. Once button is pushed door hardware will retract simultaneously with door opening. If button is not pushed after card is swiped door can be pulled open.



Hardware Group No. 30

Not to Scale

HARDWARE GROUPS BASED ON UMBS 087100 DOOR HARDWARE STANDARDS 2017 EDITION

GENERAL NOTES		
CABLE SCHEDULE		
DESIGNATION	DEVICE	CABLE CONFIGURATION
Y1	DPS	4-COND. 22 AWG NO SHIELD
Y2	CR	8-COND. 18 AWG SHIELDED W/DRAIN
Y3	RX	6-COND. 18 AWG SHIELDED NO SHIELD
Y4	EL	4-COND. 18 AWG SHIELDED NO SHIELD
Y	CR-DPS- RX-EL	COMPOSITE CABLE
P	PIM	2-CONDUCTOR 18 AWG 1 PAIR 22 AWG Shielded
P	AD-300	2-CONDUCTOR 18 AWG 1 PAIR 22 AWG Shielded
P	NDE	2-CONDUCTOR 18 AWG 1 PAIR 22 AWG Shielded
AD-WL	AD-400	WIRELESS LOCK
COMPONENT LEGEND		
CR	CARD READER	
DPS	DOOR POSITION SWITCH	
RX	REQUEST TO EXIT	
LN	LATCH BOLT MONITOR	
EL	ELECTRIC EXIT DEVICE	
ES	ELECTRIC STRIKE	
PT	ELECTRIC PASS THROUGH DEVICE	
PIM	PIM-16-485	
AD-400	AD-400 WIRELESS LOCK	
AD-300	AD-300 HARDWIRED LOCK	
NDE	NDE WIRELESS LOCK	
ES	ELECTRIC HARDWARE POWER SUPPLY	
ADA	HANDICAP OPERATOR (TYPICAL)	
PP	HANDICAP PUSH PLATE (TYPICAL)	
CABLE DESCRIPTION		
Y- WCW COMPOSITE CABLE SPECIFY RISER OR PLENUM WCW Composite Cable PN# Chord-AC-A-PL		
NON-EXTENDED CABLE		
Y-1	4-Cond. #22 AWG/STRD/NO SHIELD	WCW#444381-PL
Y-2	8-Cond. #18 AWG/STRD/SHLD W/DRAIN	WCW#002352-PL
Y-3	6-Cond. #18 AWG/STRD/NO SHIELD	WCW#U002391-04-PL
Y-4	4-Cond. #18 AWG/STRD/NO SHIELD	WCW#442380-PL
P	2-COND. #18 AWG 1 PAIR 22 AWG Shielded	WCW-92ELEMPLNTY
X- WCW COMPOSITE CABLE SPECIFY RISER OR PLENUM WCW Composite Cable PN# Chord-AC-A-EXT-PL		
EXTENDED CABLE		
X-1	4-Cond. #22 AWG/STRD/NO SHIELD	WCW#444381-PL
X-2	8-Cond. #18 AWG/STRD/SHLD W/DRAIN	WCW #002352-PL
X-3	6-Cond. #18 AWG/STRD/NO SHIELD	WCW#U002391-04-PL
X-4	4-Cond. #16 AWG/STRD/NO SHIELD	WCW#991380-PL
P	2-COND. #18 AWG 1 PAIR 22 AWG Shielded	WCW-92ELEMPLNTY

Project Name and Address
Univ of Miami
Device Elevation
SHOP DWG: SD-23

KEYED NOTES:

- ① CONCEALED DOOR POSITION SENSOR INCLUDED IN AD-400 KIT
- ② AD-400-CY-70-MS-ATH-PD (BY DIV 28)

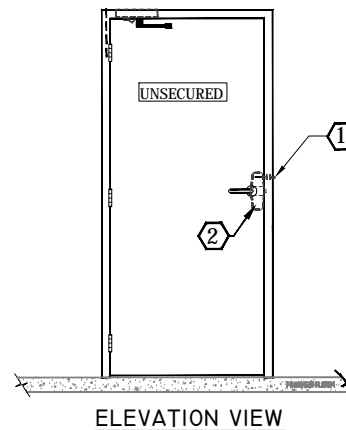
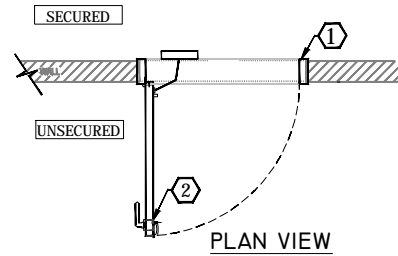

HW-31 Hardware Group No. 31
Not to Scale

HARDWARE GROUPS BASED ON
UMBS 087100 DOOR HARDWARE
STANDARDS 2017 EDITION

GENERAL NOTES
CABLE SCHEDULE

DESIGNATION	DEVICE	CABLE CONFIGURATION
Y1	DPS	4-COND. 22 AWG NO SHIELD
Y2	CR	8-COND. 18 AWG SHIELDED W/DRAIN
Y3	RX	6-COND. 18 AWG SHIELDED NO SHIELD
Y4	EL	4-COND. 18 AWG SHIELDED NO SHIELD
Y	CR-DPS-RX-EL	COMPOSITE CABLE
P	PIM	2-CONDUCTOR 18 AWG 1 PAIR 22 AWG Shielded
P	AD-300	2-CONDUCTOR 18 AWG 1 PAIR 22 AWG Shielded
P	NDE	2-CONDUCTOR 18 AWG 1 PAIR 22 AWG Shielded
AD-WL	AD-400	WIRELESS LOCK

COMPONENT LEGEND	
CR	CARD READER
DPS	DOOR POSITION SWITCH
EX	REQUEST TO EXIT
LX	LATCH BOLT MONITOR
EL	ELECTRIC EXIT DEVICE
ES	ELECTRIC STRIKE
PT	ELECTRIC PASS THROUGH DEVICE
PIM	PIM-16-485
AD-400	AD-400 WIRELESS LOCK
AD-300	AD-300 HARDWIRED LOCK
NDE	NDE WIRELESS LOCK
ES	ELECTRIC HARDWARE POWER SUPPLY
ADA	HANDICAP OPERATOR (TYPICAL)
PP	HANDICAP PUSH PLATE (TYPICAL)

CABLE DESCRIPTION		
Y- WCW COMPOSITE CABLE SPECIFY RISER OR PLENUM WCW Composite Cable PN# Cbord-AC-A-PL		
NON-EXTENDED CABLE		
Y-1	4-Cond. #22 AWG/STRD/NO SHIELD	WCW#444381-PL
Y-2	8-Cond. #18 AWG/STRD/SHLD/w/DRAIN	WCW#002352-PL
Y-3	6-Cond. #18 AWG/STRD/NO SHIELD	WCW#1002391-04-PL
Y-4	4-Cond. #18 AWG/STRD/NO SHIELD	WCW#442380-PL
P	2-COND.#18 AWG 1 PAIR 22 AWG Shielded	WCW-92ELEMPLNTY
X- WCW COMPOSITE CABLE SPECIFY RISER OR PLENUM WCW Composite Cable PN# Cbord-AC-A-EXT-PL		
EXTENDED CABLE		
X-1	4-Cond. #22 AWG/STRD/NO SHIELD	WCW#444381-PL
X-2	8-Cond. #18 AWG/STRD/SHLD/w/DRAIN	WCW#002352-PL
X-3	6-Cond. #18 AWG/STRD/NO SHIELD	WCW#1002391-04-PL
X-4	4-Cond. #18 AWG/STRD/NO SHIELD	WCW#991380-PL
P	2-COND.#18 AWG 1 PAIR 22 AWG Shielded	WCW-92ELEMPLNTY

Project Name and Address
Univ of Miami
Device Elevation
SHOP DWG: SD-24

KEYED NOTES:

- ① CONCEALED DOOR POSITION SENSOR INCLUDED IN AD-400 KIT
- ② AD-400-CY-70-MS-ATH-PD (BY DIV 28)

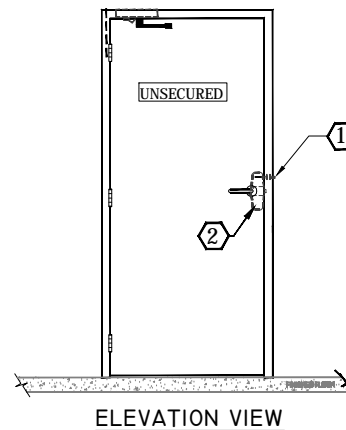
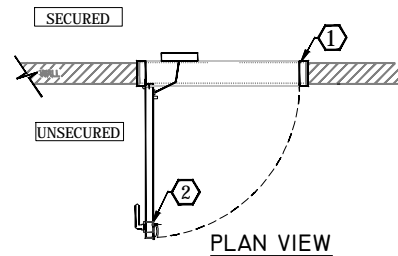

HW-32 Hardware Group No. 31
Not to Scale

HARDWARE GROUPS BASED ON
UMBS 087100 DOOR HARDWARE
STANDARDS 2017 EDITION

GENERAL NOTES
CABLE SCHEDULE

DESIGNATION	DEVICE	CABLE CONFIGURATION
Y1	DPS	4-COND. 22 AWG NO SHIELD
Y2	CR	8-COND. 18 AWG SHIELDED W/DRAIN
Y3	RX	6-COND. 18 AWG SHIELDED NO SHIELD
Y4	EL	4-COND. 18 AWG SHIELDED NO SHIELD
Y	CR-DPS-RX-EL	COMPOSITE CABLE
P	PIM	2-CONDUCTOR 18 AWG 1 PAIR 22 AWG Shielded
P	AD-300	2-CONDUCTOR 18 AWG 1 PAIR 22 AWG Shielded
P	NDE	2-CONDUCTOR 18 AWG 1 PAIR 22 AWG Shielded
AD-WL	AD-400	WIRELESS LOCK

COMPONENT LEGEND	
CR	CARD READER
DPS	DOOR POSITION SWITCH
EX	REQUEST TO EXIT
LX	LATCH BOLT MONITOR
EL	ELECTRIC EXIT DEVICE
ES	ELECTRIC STRIKE
PT	ELECTRIC PASS THROUGH DEVICE
PIM	PIM-16-485
AD-400	AD-400 WIRELESS LOCK
AD-300	AD-300 HARDWIRED LOCK
NDE	NDE WIRELESS LOCK
ES	ELECTRIC HARDWARE POWER SUPPLY
ADA	HANDICAP OPERATOR (TYPICAL)
EP	HANDICAP PUSH PLATE (TYPICAL)

CABLE DESCRIPTION		
Y- WCW COMPOSITE CABLE SPECIFY RISER OR PLENUM WCW Composite Cable PN# Cbord-AC-A-PL		
NON-EXTENDED CABLE		
Y-1	4-Cond. #22 AWG/STRD/NO SHIELD	WCW#444381-PL
Y-2	8-Cond. #18 AWG/STRD/SHLD/w/DRAIN	WCW#002352-PL
Y-3	6-Cond. #18 AWG/STRD/NO SHIELD	WCW#1002391-04-PL
Y-4	4-Cond. #18 AWG/STRD/NO SHIELD	WCW#442380-PL
P	2-COND.#18 AWG 1 PAIR 22 AWG Shielded	WCW-92ELEMPLNTY
X- WCW COMPOSITE CABLE SPECIFY RISER OR PLENUM WCW Composite Cable PN# Cbord-AC-A-EXT-PL		
EXTENDED CABLE		
X-1	4-Cond. #22 AWG/STRD/NO SHIELD	WCW#444381-PL
X-2	8-Cond. #18 AWG/STRD/SHLD/w/DRAIN	WCW#002352-PL
X-3	6-Cond. #18 AWG/STRD/NO SHIELD	WCW#1002391-04-PL
X-4	4-Cond. #18 AWG/STRD/NO SHIELD	WCW#991380-PL
P	2-COND.#18 AWG 1 PAIR 22 AWG Shielded	WCW-92ELEMPLNTY

Project Name and Address
Univ of Miami
Device Elevation
SHOP DWG: SD-25

KEYED NOTES:

- ① CONCEALED DOOR POSITION SENSOR INCLUDED IN AD-400 KIT
- ② AD-400-CY-70-MS-ATH-PD (BY DIV 28)

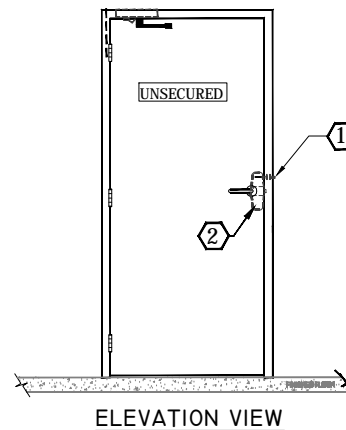
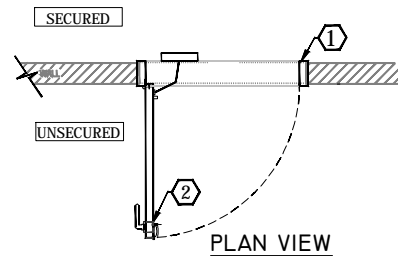

HW-33 Hardware Group No. 33
Not to Scale

HARDWARE GROUPS BASED ON
UMBS 087100 DOOR HARDWARE
STANDARDS 2017 EDITION

GENERAL NOTES
CABLE SCHEDULE

DESIGNATION	DEVICE	CABLE CONFIGURATION
Y1	DPS	4-COND. 22 AWG NO SHIELD
Y2	CR	8-COND. 18 AWG SHIELDED W/DRAIN
Y3	RX	6-COND. 18 AWG SHIELDED NO SHIELD
Y4	EL	4-COND. 18 AWG SHIELDED NO SHIELD
Y	CR-DPS-RX-EL	COMPOSITE CABLE
P	PIM	2-CONDUCTOR 18 AWG 1 PAIR 22 AWG Shielded
P	AD-300	2-CONDUCTOR 18 AWG 1 PAIR 22 AWG Shielded
P	NDE	2-CONDUCTOR 18 AWG 1 PAIR 22 AWG Shielded
AD-WL	AD-400	WIRELESS LOCK

COMPONENT LEGEND	
CR	CARD READER
DPS	DOOR POSITION SWITCH
EX	REQUEST TO EXIT
LX	LATCH BOLT MONITOR
EL	ELECTRIC EXIT DEVICE
ES	ELECTRIC STRIKE
PT	ELECTRIC PASS THROUGH DEVICE
PIM	PIM-16-485
AD-400	AD-400 WIRELESS LOCK
AD-300	AD-300 HARDWIRED LOCK
NDE	NDE WIRELESS LOCK
ES	ELECTRIC HARDWARE POWER SUPPLY
ADA	HANDICAP OPERATOR (TYPICAL)
EP	HANDICAP PUSH PLATE (TYPICAL)

CABLE DESCRIPTION		
Y- WCW COMPOSITE CABLE SPECIFY RISER OR PLENUM WCW Composite Cable PN# Cbord-AC-A-PL		
NON-EXTENDED CABLE		
Y-1	4-Cond. #22 AWG/STRD/NO SHIELD	WCW#444381-PL
Y-2	8-Cond. #18 AWG/STRD/SHLD/w/DRAIN	WCW#002352-PL
Y-3	6-Cond. #18 AWG/STRD/NO SHIELD	WCW#1002391-04-PL
Y-4	4-Cond. #18 AWG/STRD/NO SHIELD	WCW#442380-PL
P	2-COND.#18 AWG 1 PAIR 22 AWG Shielded	WCW-92ELEMPLNTY
X- WCW COMPOSITE CABLE SPECIFY RISER OR PLENUM WCW Composite Cable PN# Cbord-AC-A-EXT-PL		
EXTENDED CABLE		
X-1	4-Cond. #22 AWG/STRD/NO SHIELD	WCW#444381-PL
X-2	8-Cond. #18 AWG/STRD/SHLD/w/DRAIN	WCW#002352-PL
X-3	6-Cond. #18 AWG/STRD/NO SHIELD	WCW#1002391-04-PL
X-4	4-Cond. #18 AWG/STRD/NO SHIELD	WCW#991380-PL
P	2-COND.#18 AWG 1 PAIR 22 AWG Shielded	WCW-92ELEMPLNTY

Project Name and Address
Univ of Miami
Device Elevation
SHOP DWG: SD-26

KEYED NOTES:

- ① CONCEALED DOOR POSITION SENSOR INCLUDED IN AD-400 KIT
- ② AD-400-CY-70-MS-ATH-PD (BY DIV 28)

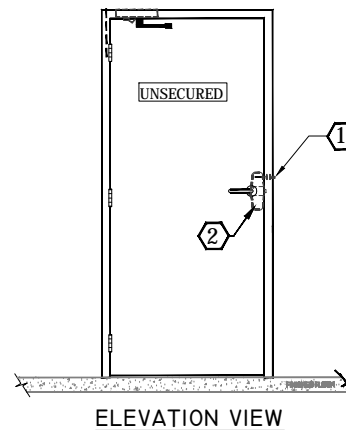
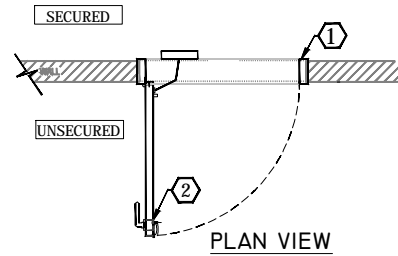

HW-34 Hardware Group No. 34
Not to Scale

HARDWARE GROUPS BASED ON
UMBS 087100 DOOR HARDWARE
STANDARDS 2017 EDITION

**GENERAL NOTES
CABLE SCHEDULE**

DESIGNATION	DEVICE	CABLE CONFIGURATION
Y1	DPS	4-COND. 22 AWG NO SHIELD
Y2	CR	8-COND. 18 AWG SHIELDED W/DRAIN
Y3	RX	6-COND. 18 AWG SHIELDED NO SHIELD
Y4	EL	4-COND. 18 AWG SHIELDED NO SHIELD
Y	CR-DPS-RX-EL	COMPOSITE CABLE
P	PIM	2-CONDUCTOR 18 AWG 1 PAIR 22 AWG Shielded
P	AD-300	2-CONDUCTOR 18 AWG 1 PAIR 22 AWG Shielded
P	NDE	2-CONDUCTOR 18 AWG 1 PAIR 22 AWG Shielded
AD-WL	AD-400	WIRELESS LOCK

COMPONENT LEGEND	
CR	CARD READER
DPS	DOOR POSITION SWITCH
EX	REQUEST TO EXIT
LX	LATCH BOLT MONITOR
EL	ELECTRIC EXIT DEVICE
ES	ELECTRIC STRIKE
PT	ELECTRIC PASS THROUGH DEVICE
PIM	PIM-16-485
AD-400	AD-400 WIRELESS LOCK
AD-300	AD-300 HARDWIRED LOCK
NDE	NDE WIRELESS LOCK
ES	ELECTRIC HARDWARE POWER SUPPLY
ADA	HANDICAP OPERATOR (TYPICAL)
PP	HANDICAP PUSH PLATE (TYPICAL)

CABLE DESCRIPTION		
Y- WCW COMPOSITE CABLE SPECIFY RISER OR PLENUM WCW Composite Cable PN# Cbord-AC-A-PL		
NON-EXTENDED CABLE		
Y-1	4-Cond. #22 AWG/STRD/NO SHIELD	WCW#444381-PL
Y-2	8-Cond. #18 AWG/STRD/SHLD/w/DRAIN	WCW#002352-PL
Y-3	6-Cond. #18 AWG/STRD/NO SHIELD	WCW#1002391-04-PL
Y-4	4-Cond. #18 AWG/STRD/NO SHIELD	WCW#442380-PL
P	2-COND.#18 AWG 1 PAIR 22 AWG Shielded	WCW-92ELEMPLNTY
X- WCW COMPOSITE CABLE SPECIFY RISER OR PLENUM WCW Composite Cable PN# Cbord-AC-A-EXT-PL		
EXTENDED CABLE		
X-1	4-Cond. #22 AWG/STRD/NO SHIELD	WCW#444381-PL
X-2	8-Cond. #18 AWG/STRD/SHLD/w/DRAIN	WCW#002352-PL
X-3	6-Cond. #18 AWG/STRD/NO SHIELD	WCW#1002391-04-PL
X-4	4-Cond. #18 AWG/STRD/NO SHIELD	WCW#991380-PL
P	2-COND.#18 AWG 1 PAIR 22 AWG Shielded	WCW-92ELEMPLNTY

Project Name and Address
**Univ of Miami
Device Elevation
SHOP DWG: SD-27**

KEYED NOTES:

- ① 1" CONDUIT TO ACCESSIBLE CEILING FOR PATHWAY AND WIRING TO SECURITY CONTROL LOCATION. (BY DIV 26)
- ② CONCEALED 6" X 8" X 3" COVERED JUNCTION BOX LOCATED NEAR DOOR ABOVE CEILING ACCESSIBLE TO SECURE SIDE. (BY DIV 26)
- ③ CONCEALED DOOR POSITION SENSOR PROVIDE $\frac{3}{4}$ " CONDUIT AND REQUIRED FRAME AND PATHWAY PREPARATION (BY DIV 26)
- ④ CONCEALED 1" DOOR POSITION SENSOR 679-05HM (BY DIV 28)
- ⑤ ALLEGION POWER TRANSFER EPT-10 (BY DIV 08)
- ⑥ PROVIDE $\frac{3}{4}$ " CONDUIT, REQUIRED FRAME AND PATHWAY PREPARATION FOR WIREWAY THROUGH DOOR (BY DIV 26)
- ⑦ EXIT DEVICE: RX-QEL+-HH-9847-EO-SNB CONCEALED VERTICAL RODS (BY DIV 28)
- ⑧ MOUNT SINGE GANG JUNCTION BOX AND CONDUIT FOR CARD READER (BY DIV 26)
- ⑨ MOUNT MTMS15 CARD READER ON UNSECURE SIDE 42" AFF AND 6" OPTIMUM FROM DOOR. (BY DIV 28)
- ⑩ DOOR HARDWARE POWER SUPPLY. PS902 900-2RS (BY DIV 28)
- ⑪ 120 VAC CIRCUIT (DIV 26).

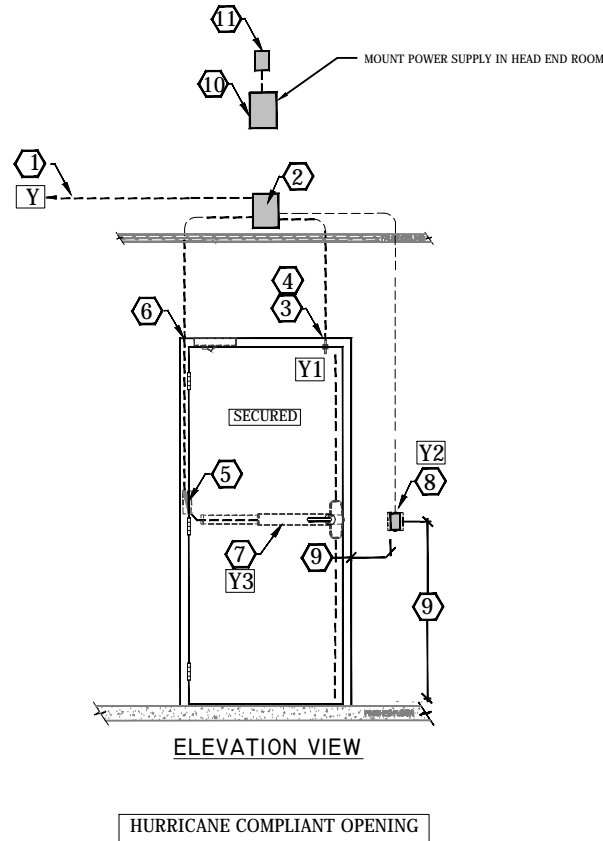

GENERAL NOTES CABLE SCHEDULE		
DESIGNATION	DEVICE	CABLE CONFIGURATION
Y1	DPS	4-COND. 22 AWG NO SHIELD
Y2	CR	8-COND. 18 AWG SHIELDED W/DRAIN
Y3	RX	6-COND. 18 AWG SHIELDED NO SHIELD
Y4	EL	4-COND. 18 AWG SHIELDED NO SHIELD
Y	CR-DPS- RX-EL	COMPOSITE CABLE
P	PIM	2-CONDUCTOR 18 AWG 1 PAIR 22 AWG Shielded
P	AD-300	2-CONDUCTOR 18 AWG 1 PAIR 22 AWG Shielded
P	NDE	2-CONDUCTOR 18 AWG 1 PAIR 22 AWG Shielded
AD-WL	AD-400	WIRELESS LOCK
COMPONENT LEGEND		
CR	CARD READER	
DPS	DOOR POSITION SWITCH	
EX	REQUEST TO EXIT	
LX	LATCH BOLT MONITOR	
EL	ELECTRIC EXIT DEVICE	
ES	ELECTRIC STRIKE	
EP	ELECTRIC PASS THROUGH DEVICE	
PIM	PIM-16-485	
AD-400	AD-400 WIRELESS LOCK	
AD-300	AD-300 HARDWIRED LOCK	
NDE	NDE WIRELESS LOCK	
ES	ELECTRIC HARDWARE POWER SUPPLY	
ADA	HANDICAP OPERATOR (TYPICAL)	
EP	HANDICAP PUSH PLATE (TYPICAL)	
CABLE DESCRIPTION		
Y- WCW COMPOSITE CABLE SPECIFY RISER OR PLENUM WCW Composite Cable PN# Chord-AC-A-PL		
NON-EXTENDED CABLE		
Y-1	4-Cond. #22 AWG/STRD/NO SHIELD	WCW#444381-PL
Y-2	8-Cond. #18 AWG/STRD/SHLD W/DRAIN	WCW#002352-PL
Y-3	6-Cond. #18 AWG/STRD/NO SHIELD	WCW#U002391-04-PL
Y-4	4-Cond. #18 AWG/STRD/NO SHIELD	WCW#442380-PL
P	2-COND.#18 AWG 1 PAIR 22 AWG Shielded	WCW-92ELEMPLNTY
X- WCW COMPOSITE CABLE SPECIFY RISER OR PLENUM WCW Composite Cable PN# Chord-AC-A-EXT-PL		
EXTENDED CABLE		
X-1	4-Cond. #22 AWG/STRD/NO SHIELD	WCW#444381-PL
X-2	8-Cond. #18 AWG/STRD/SHLD W/DRAIN	WCW #002352-PL
X-3	6-Cond. #18 AWG/STRD/NO SHIELD	WCW#U002391-04-PL
X-4	4-Cond. #16 AWG/STRD/NO SHIELD	WCW#991380-PL
P	2-COND.#18 AWG 1 PAIR 22 AWG Shielded	WCW-92ELEMPLNTY



Hardware Group No. 35 CARD ACCESS STOREFRONT

Not to Scale

HARDWARE GROUPS BASED ON
UMBS 087100 DOOR HARDWARE
STANDARDS 2017 EDITION

Project Name and Address
**Univ of Miami
Device Elevation**
SHOP DWG: SD-28

KEYED NOTES:

- ① 1" CONDUIT TO ACCESSIBLE CEILING FOR PATHWAY AND WIRING TO SECURITY CONTROL LOCATION. (BY DIV 26)
- ② CONCEALED 6" X 8" X 3" COVERED JUNCTION BOX LOCATED NEAR DOOR ABOVE CEILING ACCESSIBLE TO SECURE SIDE. (BY DIV 26)
- ③ CONCEALED DOOR POSITION SENSOR PROVIDE $\frac{3}{4}$ " CONDUIT AND REQUIRED FRAME AND PATHWAY PREPARATION (BY DIV 26)
- ④ CONCEALED 1" DOOR POSITION SENSOR 679-05HM (BY DIV 28)
- ⑤ ALLEGION POWER TRANSFER EPT-10 (BY DIV 08)
- ⑥ PROVIDE $\frac{3}{4}$ " CONDUIT, REQUIRED FRAME AND PATHWAY PREPARATION FOR WIREWAY THROUGH DOOR (BY DIV 26)
- ⑦ EU MORTISE LOCK: L9492JEU 07A (BY DIV 08)
- ⑧ MOUNT SINGE GANG JUNCTION BOX AND CONDUIT FOR CARD READER (BY DIV 26)
- ⑨ MOUNT MTMS15 CARD READER ON UNSECURE SIDE 42" AFF AND 6" OPTIMUM FROM DOOR. (BY DIV 28)
- ⑩ DOOR HARDWARE POWER SUPPLY. PS902 900-2RS (BY DIV 28)
- ⑪ 120 VAC CIRCUIT (DIV 26).

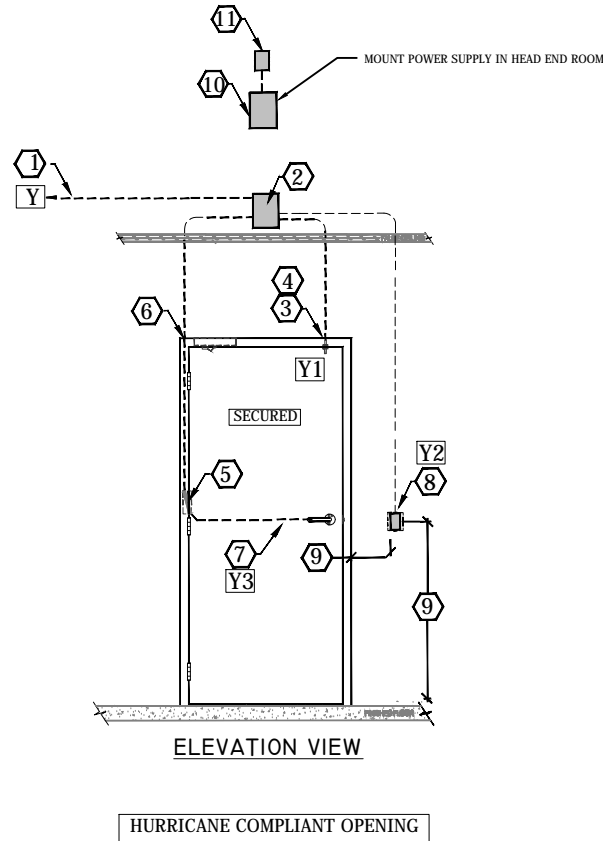

**GENERAL NOTES
CABLE SCHEDULE**

DESIGNATION	DEVICE	CABLE CONFIGURATION
Y1	DPS	4-COND. 22 AWG NO SHIELD
Y2	CR	8-COND. 18 AWG SHIELDED W/DRAIN
Y3	RX	6-COND. 18 AWG SHIELDED NO SHIELD
Y4	EL	4-COND. 18 AWG SHIELDED NO SHIELD
Y	CR-DPS- RX-EL	COMPOSITE CABLE
P	PIM	2-CONDUCTOR 18 AWG 1 PAIR 22 AWG Shielded
P	AD-300	2-CONDUCTOR 18 AWG 1 PAIR 22 AWG Shielded
P	NDE	2-CONDUCTOR 18 AWG 1 PAIR 22 AWG Shielded
AD-WL	AD-400	WIRELESS LOCK

COMPONENT LEGEND

CR	CARD READER
DPS	DOOR POSITION SWITCH
EX	REQUEST TO EXIT
LX	LATCH BOLT MONITOR
EL	ELECTRIC EXIT DEVICE
ES	ELECTRIC STRIKE
EP	ELECTRIC PASS THROUGH DEVICE
PIM	PIM-16-485
AD-400	AD-400 WIRELESS LOCK
AD-300	AD-300 HARDWIRED LOCK
NDE	NDE WIRELESS LOCK
ES	ELECTRIC HARDWARE POWER SUPPLY
ABA	HANDICAP OPERATOR (TYPICAL)
EP	HANDICAP PUSH PLATE (TYPICAL)

CABLE DESCRIPTION

Y- WCW COMPOSITE CABLE
SPECIFY RISER OR PLENUM
WCW Composite Cable
PN# Chord-AC-A-PL

NON-EXTENDED CABLE

Y-1	4-Cond. #22 AWG/STRD/NO SHIELD	WCW#444381-PL
Y-2	8-Cond. #18 AWG/STRD/SHLD W/DRAIN	WCW#002352-PL
Y-3	6-Cond. #18 AWG/STRD/NO SHIELD	WCW#U002391-04-PL
Y-4	4-Cond. #18 AWG/STRD/NO SHIELD	WCW#442380-PL
P	2-COND.#18 AWG 1 PAIR 22 AWG Shielded	WCW-92ELEMPINTY

X- WCW COMPOSITE CABLE
SPECIFY RISER OR PLENUM
WCW Composite Cable
PN# Chord-AC-A-EXT-PL

EXTENDED CABLE

X-1	4-Cond. #22 AWG/STRD/NO SHIELD	WCW#444381-PL
X-2	8-Cond. #18 AWG/STRD/SHLD W/DRAIN	WCW #002352-PL
X-3	6-Cond. #18 AWG/STRD/NO SHIELD	WCW#U002391-04-PL
X-4	4-Cond. #16 AWG/STRD/NO SHIELD	WCW#991380-PL
P	2-COND.#18 AWG 1 PAIR 22 AWG Shielded	WCW-92ELEMPINTY

HW-36 Hardware Group No. 36
Not to Scale

HARDWARE GROUPS BASED ON
UMBS 087100 DOOR HARDWARE
STANDARDS 2017 EDITION

Project Name and Address
Univ of Miami
Device Elevation
SHOP DWG: SD-29

KEYED NOTES:

- ① CONCEALED DOOR POSITION SENSOR INCLUDED IN AD-400 KIT
- ② AD-400-CY-70-MS-ATH-PD (BY DIV 28)

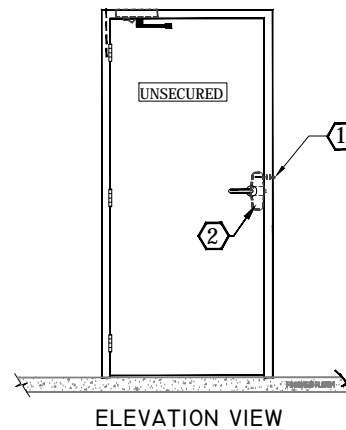
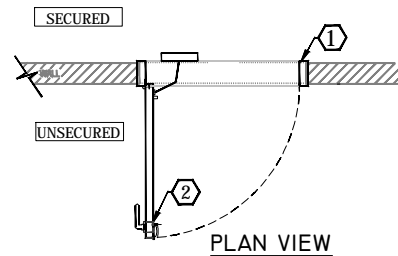

HW-39 Hardware Group No. 39
Not to Scale

HARDWARE GROUPS BASED ON
UMBS 087100 DOOR HARDWARE
STANDARDS 2017 EDITION

GENERAL NOTES
CABLE SCHEDULE

DESIGNATION	DEVICE	CABLE CONFIGURATION
Y1	DPS	4-COND. 22 AWG NO SHIELD
Y2	CR	8-COND. 18 AWG SHIELDED W/DRAIN
Y3	RX	6-COND. 18 AWG SHIELDED NO SHIELD
Y4	EL	4-COND. 18 AWG SHIELDED NO SHIELD
Y	CR-DPS-RX-EL	COMPOSITE CABLE
P	PIM	2-CONDUCTOR 18 AWG 1 PAIR 22 AWG Shielded
P	AD-300	2-CONDUCTOR 18 AWG 1 PAIR 22 AWG Shielded
P	NDE	2-CONDUCTOR 18 AWG 1 PAIR 22 AWG Shielded
AD-WL	AD-400	WIRELESS LOCK

COMPONENT LEGEND	
CR	CARD READER
DPS	DOOR POSITION SWITCH
EX	REQUEST TO EXIT
LX	LATCH BOLT MONITOR
EL	ELECTRIC EXIT DEVICE
ES	ELECTRIC STRIKE
PT	ELECTRIC PASS THROUGH DEVICE
PIM	PIM-16-485
AD-400	AD-400 WIRELESS LOCK
AD-300	AD-300 HARDWIRED LOCK
NDE	NDE WIRELESS LOCK
ES	ELECTRIC HARDWARE POWER SUPPLY
ADA	HANDICAP OPERATOR (TYPICAL)
EP	HANDICAP PUSH PLATE (TYPICAL)

CABLE DESCRIPTION		
Y- WCW COMPOSITE CABLE SPECIFY RISER OR PLENUM WCW Composite Cable PN# Cbord-AC-A-PL		
NON-EXTENDED CABLE		
Y-1	4-Cond. #22 AWG/STRD/NO SHIELD	WCW#444381-PL
Y-2	8-Cond. #18 AWG/STRD/SHLD/w/DRAIN	WCW#002352-PL
Y-3	6-Cond. #18 AWG/STRD/NO SHIELD	WCW#1002391-04-PL
Y-4	4-Cond. #18 AWG/STRD/NO SHIELD	WCW#442380-PL
P	2-COND.#18 AWG 1 PAIR 22 AWG Shielded	WCW-92ELEMPLNTY
X- WCW COMPOSITE CABLE SPECIFY RISER OR PLENUM WCW Composite Cable PN# Cbord-AC-A-EXT-PL		
EXTENDED CABLE		
X-1	4-Cond. #22 AWG/STRD/NO SHIELD	WCW#444381-PL
X-2	8-Cond. #18 AWG/STRD/SHLD/w/DRAIN	WCW#002352-PL
X-3	6-Cond. #18 AWG/STRD/NO SHIELD	WCW#1002391-04-PL
X-4	4-Cond. #16 AWG/STRD/NO SHIELD	WCW#991380-PL
P	2-COND.#18 AWG 1 PAIR 22 AWG Shielded	WCW-92ELEMPLNTY

Project Name and Address
Univ of Miami
Device Elevation
SHOP DWG: SD-30

KEYED NOTES:

- ① CONCEALED DOOR POSITION SENSOR INCLUDED IN AD-400 KIT
- ② AD-400-CY-70-MS-ATH-PD (BY DIV 28)

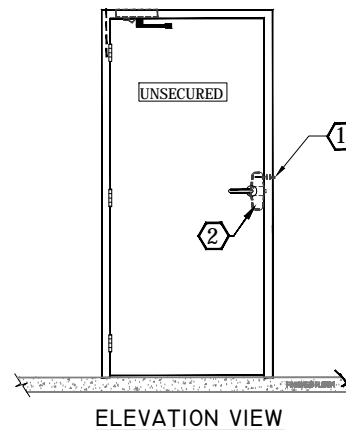
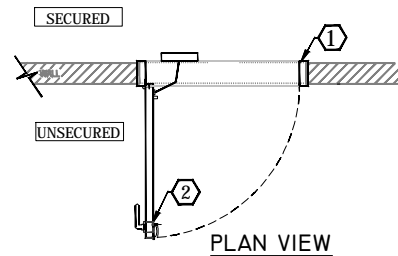

HW-40 Hardware Group No. 40
Not to Scale

HARDWARE GROUPS BASED ON
UMBS 087100 DOOR HARDWARE
STANDARDS 2017 EDITION

GENERAL NOTES
CABLE SCHEDULE

DESIGNATION	DEVICE	CABLE CONFIGURATION
Y1	DPS	4-COND. 22 AWG NO SHIELD
Y2	CR	8-COND. 18 AWG SHIELDED W/DRAIN
Y3	RX	6-COND. 18 AWG SHIELDED NO SHIELD
Y4	EL	4-COND. 18 AWG SHIELDED NO SHIELD
Y	CR-DPS-RX-EL	COMPOSITE CABLE
P	PIM	2-CONDUCTOR 18 AWG 1 PAIR 22 AWG Shielded
P	AD-300	2-CONDUCTOR 18 AWG 1 PAIR 22 AWG Shielded
P	NDE	2-CONDUCTOR 18 AWG 1 PAIR 22 AWG Shielded
AD-WL	AD-400	WIRELESS LOCK

COMPONENT LEGEND

CR	CARD READER
DPS	DOOR POSITION SWITCH
EX	REQUEST TO EXIT
LX	LATCH BOLT MONITOR
EL	ELECTRIC EXIT DEVICE
ES	ELECTRIC STRIKE
PT	ELECTRIC PASS THROUGH DEVICE
PIM	PIM-16-485
AD-400	AD-400 WIRELESS LOCK
AD-300	AD-300 HARDWIRED LOCK
NDE	NDE WIRELESS LOCK
ES	ELECTRIC HARDWARE POWER SUPPLY
ADA	HANDICAP OPERATOR (TYPICAL)
EP	HANDICAP PUSH PLATE (TYPICAL)

CABLE DESCRIPTION

Y- WCW COMPOSITE CABLE
SPECIFY RISER OR PLENUM
WCW Composite Cable
PN# Cbord-AC-A-PL

NON-EXTENDED CABLE

Y-1	4-Cond. #22 AWG/STRD/NO SHIELD	WCW#444381-PL
Y-2	8-Cond. #18 AWG/STRD/SHLD/w/DRAIN	WCW#002352-PL
Y-3	6-Cond. #18 AWG/STRD/NO SHIELD	WCW#1002391-04-PL
Y-4	4-Cond. #18 AWG/STRD/NO SHIELD	WCW#442380-PL
P	2-COND.#18 AWG 1 PAIR 22 AWG Shielded	WCW-92ELEMPLNTY

X- WCW COMPOSITE CABLE
SPECIFY RISER OR PLENUM
WCW Composite Cable
PN# Cbord-AC-A-EXT-PL

EXTENDED CABLE

X-1	4-Cond. #22 AWG/STRD/NO SHIELD	WCW#444381-PL
X-2	8-Cond. #18 AWG/STRD/SHLD/w/DRAIN	WCW#002352-PL
X-3	6-Cond. #18 AWG/STRD/NO SHIELD	WCW#1002391-04-PL
X-4	4-Cond. #18 AWG/STRD/NO SHIELD	WCW#991380-PL
P	2-COND.#18 AWG 1 PAIR 22 AWG Shielded	WCW-92ELEMPLNTY

Project Name and Address
Univ of Miami
Device Elevation
SHOP DWG: SD-31

KEYED NOTES:

- ① 1" CONDUIT TO ACCESSIBLE CEILING FOR PATHWAY AND WIRING TO SECURITY CONTROL LOCATION. (BY DIV 26)
- ② CONCEALED 6" X 8" X 3" COVERED JUNCTION BOX LOCATED NEAR DOOR ABOVE CEILING ACCESSIBLE TO SECURE SIDE. (BY DIV 26)
- ③ CONCEALED DOOR POSITION SENSOR PROVIDE 3/4" CONDUIT AND REQUIRED FRAME AND PATHWAY PREPARATION (BY DIV 26)
- ④ CONCEALED 1" DOOR POSITION SENSOR 679-05HM (DIV 28)
- ⑤ MOTION SENSOR SCANII (DIV 28)
- ⑥ PROVIDE 3/4" CONDUIT, REQUIRED FRAME AND PATHWAY PREPARATION (BY DIV 26)
- ⑦ PUSH BUTTON 621ALEX DA (BY DIV. 28)
- ⑧ MOUNT SINGLE GANG JUNCTION BOX AND 3/4" CONDUIT FOR CARD READER AND PUSHBUTTON. (BY DIV 26)
- ⑨ MOUNT MTMS15 CARD READER ON UNSECURE SIDE 42" AFF AND 6" OPTIMUM FROM DOOR. (BY DIV 28)
- ⑩ DOOR HARDWARE POWER SUPPLY. PS902 900-FA (BY DIV 28)
- ⑪ 120 VAC CIRCUIT (DIV 26).
- ⑫ MAGNETIC LOCK M420P (BY DIV 28)

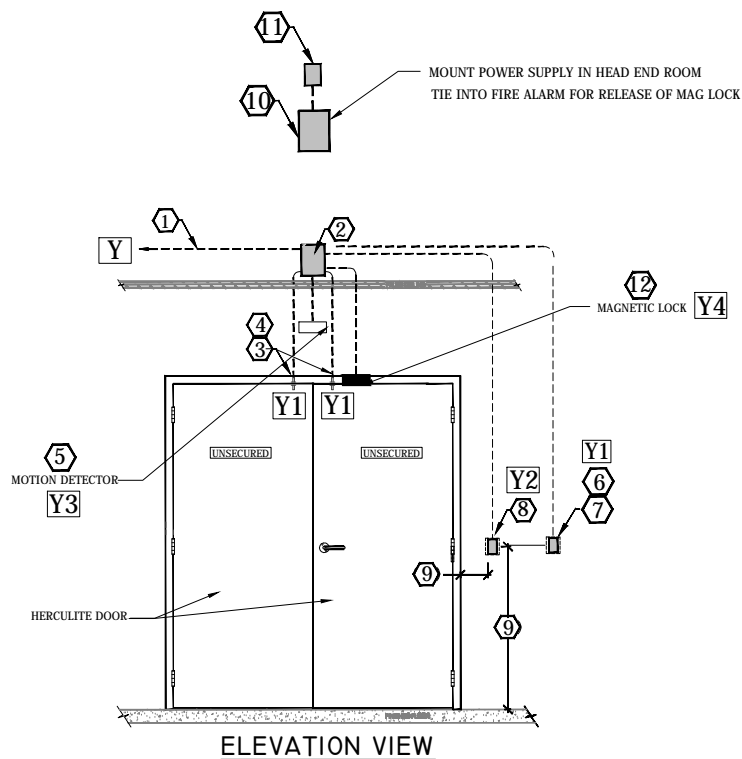

MOUNT POWER SUPPLY IN HEAD END ROOM
TIE INTO FIRE ALARM FOR RELEASE OF MAG LOCK

**GENERAL NOTES
CABLE SCHEDULE**

DESIGNATION	DEVICE	CABLE CONFIGURATION
Y1	DPS	4-COND. 22 AWG NO SHIELD
Y2	CR	8-COND. 18 AWG SHIELDED W/DRAIN
Y3	RX	6-COND. 18 AWG SHIELDED NO SHIELD
Y4	EL	4-COND. 18 AWG SHIELDED NO SHIELD
Y	CR-DPS- RX-EL	COMPOSITE CABLE
P	PIM	2-CONDUCTOR 18 AWG 1 PAIR 22 AWG Shielded
P	AD-300	2-CONDUCTOR 18 AWG 1 PAIR 22 AWG Shielded
P	NDE	2-CONDUCTOR 18 AWG 1 PAIR 22 AWG Shielded
AD-WL	AD-400	WIRELESS LOCK

COMPONENT LEGEND

CR	CARD READER
DPS	DOOR POSITION SWITCH
RX	REQUEST TO EXIT
LX	LATCH BOLT MONITOR
EL	ELECTRIC EXIT DEVICE
ES	ELECTRIC STRIKE
PT	ELECTRIC PASS THROUGH DEVICE
PIM	PIM-16-485
AD-400	AD-400 WIRELESS LOCK
AD-300	AD-300 HARDWIRED LOCK
NDE	NDE WIRELESS LOCK
ES	ELECTRIC HARDWARE POWER SUPPLY
ADA	HANDICAP OPERATOR (TYPICAL)
PP	HANDICAP PUSH PLATE (TYPICAL)

CABLE DESCRIPTION

Y- WCW COMPOSITE CABLE SPECIFY RISER OR PLENUM WCW Composite Cable PN# Chord-AC-A-PL		
NON-EXTENDED CABLE		
Y-1	4-Cond. #22 AWG/STRD/NO SHIELD	WCW#444381-PL
Y-2	8-Cond. #18 AWG/STRD/SHLD W/DRAIN	WCW#002352-PL
Y-3	6-Cond. #18 AWG/STRD/NO SHIELD	WCW#U002391-04-PL
Y-4	4-Cond. #18 AWG/STRD/NO SHIELD	WCW#442380-PL
P	2-COND. #18 AWG 1 PAIR 22 AWG Shielded	WCW-92ELEMPLNTY
X- WCW COMPOSITE CABLE SPECIFY RISER OR PLENUM WCW Composite Cable PN# Chord-AC-A-EXT-PL		
EXTENDED CABLE		
X-1	4-Cond. #22 AWG/STRD/NO SHIELD	WCW#444381-PL
X-2	8-Cond. #18 AWG/STRD/SHLD W/DRAIN	WCW #002352-PL
X-3	6-Cond. #18 AWG/STRD/NO SHIELD	WCW#U002391-04-PL
X-4	4-Cond. #16 AWG/STRD/NO SHIELD	WCW#991380-PL
P	2-COND. #18 AWG 1 PAIR 22 AWG Shielded	WCW-92ELEMPLNTY

Project Name and Address

Univ of Miami
Device Elevation
SHOP DWG: DD-6



Hardware Group No. 43

Not to Scale

HARDWARE GROUPS BASED ON
UMBS 087100 DOOR HARDWARE
STANDARDS 2017 EDITION

KEYED NOTES:

- ① CONCEALED DOOR POSITION SENSOR INCLUDED IN AD-400 KIT
- ② AD-400-CY-70-MS-8AT ATH-PD (BY DIV 28)
- ③ SURFACE BOLT (BY DIV 8)

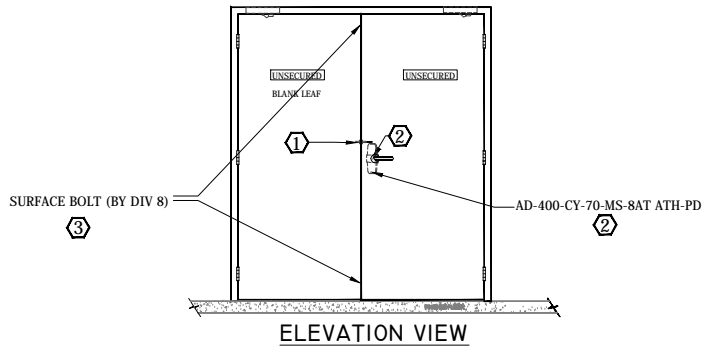
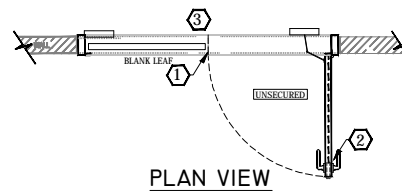

HW-45 Hardware Group No. 45
Not to Scale

**GENERAL NOTES
CABLE SCHEDULE**

DESIGNATION	DEVICE	CABLE CONFIGURATION
Y1	DPS	4-COND. 22 AWG NO SHIELD
Y2	CR	8-COND. 18 AWG SHIELDED W/DRAIN
Y3	RX	6-COND. 18 AWG SHIELDED NO SHIELD
Y4	EL	4-COND. 18 AWG SHIELDED NO SHIELD
Y	CR-DPS- RX-EL	COMPOSITE CABLE
P	PIM	2-CONDUCTOR 18 AWG 1 PAIR 22 AWG Shielded
P	AD-300	2-CONDUCTOR 18 AWG 1 PAIR 22 AWG Shielded
P	NDE	2-CONDUCTOR 18 AWG 1 PAIR 22 AWG Shielded
AD-WL	AD-400	WIRELESS LOCK

COMPONENT LEGEND

CR	CARD READER
DPS	DOOR POSITION SWITCH
RX	REQUEST TO EXIT
LX	LATCH BOLT MONITOR
EL	ELECTRIC EXIT DEVICE
ES	ELECTRIC STRIKE
PT	ELECTRIC PASS THROUGH DEVICE
PIM	PIM-16-485
AD-400	AD-400 WIRELESS LOCK
AD-300	AD-300 HARDWIRED LOCK
NDE	NDE WIRELESS LOCK
ES	ELECTRIC HARDWARE POWER SUPPLY
ADA	HANDICAP OPERATOR (TYPICAL)
PP	HANDICAP PUSH PLATE (TYPICAL)

CABLE DESCRIPTION

Y- WCW COMPOSITE CABLE SPECIFY RISER OR PLENUM WCW Composite Cable PN# Chord-AC-A-PL		
NON-EXTENDED CABLE		
Y-1	4-Cond. #22 AWG/STRD/NO SHIELD	WCW#444381-PL
Y-2	8-Cond. #18 AWG/STRD/SHLD W/DRAIN	WCW#002352-PL
Y-3	6-Cond. #18 AWG/STRD/NO SHIELD	WCW#U002391-04-PL
Y-4	4-Cond. #18 AWG/STRD/NO SHIELD	WCW#442380-PL
P	2-COND. #18 AWG 1 PAIR 22 AWG Shielded	WCW-92ELEMPLNTY
X- WCW COMPOSITE CABLE SPECIFY RISER OR PLENUM WCW Composite Cable PN# Chord-AC-A-EXT-PL		
EXTENDED CABLE		
X-1	4-Cond. #22 AWG/STRD/NO SHIELD	WCW#444381-PL
X-2	8-Cond. #18 AWG/STRD/SHLD W/DRAIN	WCW #002352-PL
X-3	6-Cond. #18 AWG/STRD/NO SHIELD	WCW#U002391-04-PL
X-4	4-Cond. #16 AWG/STRD/NO SHIELD	WCW#991380-PL
P	2-COND. #18 AWG 1 PAIR 22 AWG Shielded	WCW-92ELEMPLNTY

Project Name and Address

Univ of Miami
Device Elevation
SHOP DWG: DD-7

KEYED NOTES:

- ① CONCEALED DOOR POSITION SENSOR INCLUDED IN AD-400 KIT
- ② AD-400-CY-70-MS-8AT ATH-PD (BY DIV 28)
- ③ SURFACE BOLT (BY DIV 8)

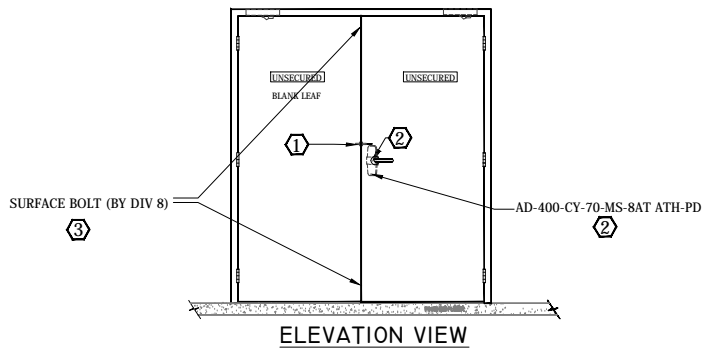
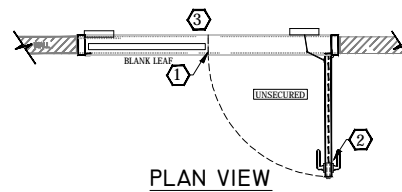

HW-46 Hardware Group No. 46
Not to Scale

HARDWARE GROUPS BASED ON
UMBS 087100 DOOR HARDWARE
STANDARDS 2017 EDITION

GENERAL NOTES
CABLE SCHEDULE

DESIGNATION	DEVICE	CABLE CONFIGURATION
Y1	DPS	4-COND. 22 AWG NO SHIELD
Y2	CR	8-COND. 18 AWG SHIELDED W/DRAIN
Y3	RX	6-COND. 18 AWG SHIELDED NO SHIELD
Y4	EL	4-COND. 18 AWG SHIELDED NO SHIELD
Y	CR-DPS- RX-EL	COMPOSITE CABLE
P	PIM	2-CONDUCTOR 18 AWG 1 PAIR 22 AWG Shielded
P	AD-300	2-CONDUCTOR 18 AWG 1 PAIR 22 AWG Shielded
P	NDE	2-CONDUCTOR 18 AWG 1 PAIR 22 AWG Shielded
AD-WL	AD-400	WIRELESS LOCK

COMPONENT LEGEND

CR	CARD READER
DPS	DOOR POSITION SWITCH
RX	REQUEST TO EXIT
LX	LATCH BOLT MONITOR
EL	ELECTRIC EXIT DEVICE
ES	ELECTRIC STRIKE
PT	ELECTRIC PASS THROUGH DEVICE
PIM	PIM-16-485
AD-400	AD-400 WIRELESS LOCK
AD-300	AD-300 HARDWIRED LOCK
NDE	NDE WIRELESS LOCK
ES	ELECTRIC HARDWARE POWER SUPPLY
ADA	HANDICAP OPERATOR (TYPICAL)
PP	HANDICAP PUSH PLATE (TYPICAL)

CABLE DESCRIPTION

Y- WCW COMPOSITE CABLE SPECIFY RISER OR PLENUM WCW Composite Cable PN# Chord-AC-A-PL NON-EXTENDED CABLE		
Y-1	4-Cond. #22 AWG/STRD/NO SHIELD	WCW#444381-PL
Y-2	8-Cond. #18 AWG/STRD/SHLD W/DRAIN	WCW#002352-PL
Y-3	6-Cond. #18 AWG/STRD/NO SHIELD	WCW#U002391-04-PL
Y-4	4-Cond. #18 AWG/STRD/NO SHIELD	WCW#442380-PL
P	2-COND. #18 AWG 1 PAIR 22 AWG Shielded	WCW-92ELEMPLNTY
X- WCW COMPOSITE CABLE SPECIFY RISER OR PLENUM WCW Composite Cable PN# Chord-AC-A-EXT-PL EXTENDED CABLE		
X-1	4-Cond. #22 AWG/STRD/NO SHIELD	WCW#444381-PL
X-2	8-Cond. #18 AWG/STRD/SHLD W/DRAIN	WCW #002352-PL
X-3	6-Cond. #18 AWG/STRD/NO SHIELD	WCW#U002391-04-PL
X-4	4-Cond. #16 AWG/STRD/NO SHIELD	WCW#991380-PL
P	2-COND. #18 AWG 1 PAIR 22 AWG Shielded	WCW-92ELEMPLNTY

Project Name and Address

Univ of Miami
Device Elevation
SHOP DWG: DD-8

KEYED NOTES:

- ① CONCEALED DOOR POSITION SENSOR INCLUDED IN AD-400 KIT
- ② AD-400-CY-70-MS-8AT ATH-PD (BY DIV 28)
- ③ SURFACE BOLT (BY DIV 8)

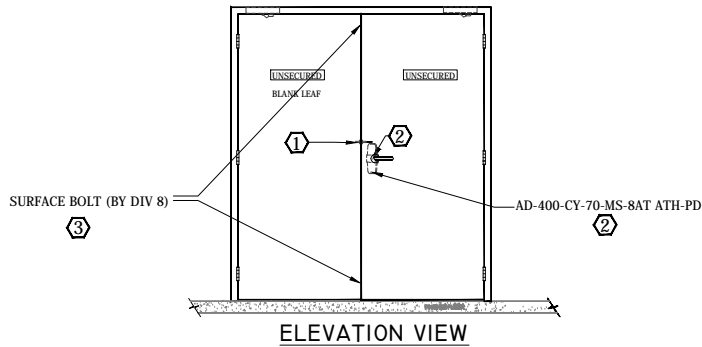
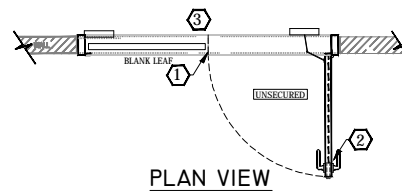

HW-47 Hardware Group No. 47
Not to Scale

HARDWARE GROUPS BASED ON
UMBS 087100 DOOR HARDWARE
STANDARDS 2017 EDITION

GENERAL NOTES
CABLE SCHEDULE

DESIGNATION	DEVICE	CABLE CONFIGURATION
Y1	DPS	4-COND. 22 AWG NO SHIELD
Y2	CR	8-COND. 18 AWG SHIELDED W/DRAIN
Y3	RX	6-COND. 18 AWG SHIELDED NO SHIELD
Y4	EL	4-COND. 18 AWG SHIELDED NO SHIELD
Y	CR-DPS- RX-EL	COMPOSITE CABLE
P	PIM	2-CONDUCTOR 18 AWG 1 PAIR 22 AWG Shielded
P	AD-300	2-CONDUCTOR 18 AWG 1 PAIR 22 AWG Shielded
P	NDE	2-CONDUCTOR 18 AWG 1 PAIR 22 AWG Shielded
AD-WL	AD-400	WIRELESS LOCK

COMPONENT LEGEND

CR	CARD READER
DPS	DOOR POSITION SWITCH
RX	REQUEST TO EXIT
LX	LATCH BOLT MONITOR
EL	ELECTRIC EXIT DEVICE
ES	ELECTRIC STRIKE
PT	ELECTRIC PASS THROUGH DEVICE
PIM	PIM-16-485
AD-400	AD-400 WIRELESS LOCK
AD-300	AD-300 HARDWIRED LOCK
NDE	NDE WIRELESS LOCK
ES	ELECTRIC HARDWARE POWER SUPPLY
ADA	HANDICAP OPERATOR (TYPICAL)
PP	HANDICAP PUSH PLATE (TYPICAL)

CABLE DESCRIPTION

Y- WCW COMPOSITE CABLE SPECIFY RISER OR PLENUM WCW Composite Cable PN# Chord-AC-A-PL NON-EXTENDED CABLE		
Y-1	4-Cond. #22 AWG/STRD/NO SHIELD	WCW#444381-PL
Y-2	8-Cond. #18 AWG/STRD/SHLD W/DRAIN	WCW#002352-PL
Y-3	6-Cond. #18 AWG/STRD/NO SHIELD	WCW#U002391-04-PL
Y-4	4-Cond. #18 AWG/STRD/NO SHIELD	WCW#442380-PL
P	2-COND. #18 AWG 1 PAIR 22 AWG Shielded	WCW-92ELEMPLNTY
X- WCW COMPOSITE CABLE SPECIFY RISER OR PLENUM WCW Composite Cable PN# Chord-AC-A-EXT-PL EXTENDED CABLE		
X-1	4-Cond. #22 AWG/STRD/NO SHIELD	WCW#444381-PL
X-2	8-Cond. #18 AWG/STRD/SHLD W/DRAIN	WCW #002352-PL
X-3	6-Cond. #18 AWG/STRD/NO SHIELD	WCW#U002391-04-PL
X-4	4-Cond. #16 AWG/STRD/NO SHIELD	WCW#991380-PL
P	2-COND. #18 AWG 1 PAIR 22 AWG Shielded	WCW-92ELEMPLNTY

Project Name and Address

Univ of Miami
Device Elevation
SHOP DWG: DD-9

KEYED NOTES:

- ① CONCEALED DOOR POSITION SENSOR INCLUDED IN AD-400 KIT
- ② AD-400-993R-70-MS-ATH-PD (BY DIV 28)
- ③ EXIT DEVICE RX-LC-9875-EO (BY DIV 8)
- ④ SURFACE BOLT (BY DIV 8)

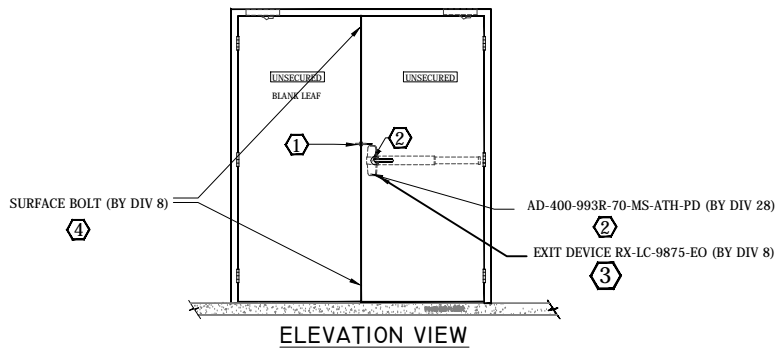
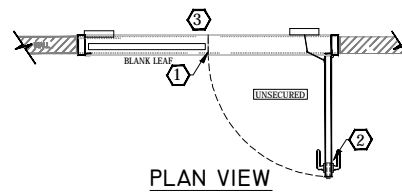

EXIT DEVICE RX-LC-9875-EO (BY DIV 8)

HW-48 Hardware Group No. 48
Not to Scale

HARDWARE GROUPS BASED ON
UMBS 087100 DOOR HARDWARE
STANDARDS 2017 EDITION

GENERAL NOTES
CABLE SCHEDULE

DESIGNATION	DEVICE	CABLE CONFIGURATION
Y1	DPS	4-COND. 22 AWG NO SHIELD
Y2	CR	8-COND. 18 AWG SHIELDED W/DRAIN
Y3	RX	6-COND. 18 AWG SHIELDED NO SHIELD
Y4	EL	4-COND. 18 AWG SHIELDED NO SHIELD
Y	CR-DPS- RX-EL	COMPOSITE CABLE
P	PIM	2-CONDUCTOR 18 AWG 1 PAIR 22 AWG Shielded
P	AD-300	2-CONDUCTOR 18 AWG 1 PAIR 22 AWG Shielded
P	NDE	2-CONDUCTOR 18 AWG 1 PAIR 22 AWG Shielded
AD-WL	AD-400	WIRELESS LOCK

COMPONENT LEGEND

CR	CARD READER
DPS	DOOR POSITION SWITCH
RX	REQUEST TO EXIT
LX	LATCH BOLT MONITOR
EL	ELECTRIC EXIT DEVICE
ES	ELECTRIC STRIKE
PT	ELECTRIC PASS THROUGH DEVICE
PIM	PIM-16-485
AD-400	AD-400 WIRELESS LOCK
AD-300	AD-300 HARDWIRED LOCK
NDE	NDE WIRELESS LOCK
ES	ELECTRIC HARDWARE POWER SUPPLY
ADA	HANDICAP OPERATOR (TYPICAL)
PP	HANDICAP PUSH PLATE (TYPICAL)

CABLE DESCRIPTION

Y- WCW COMPOSITE CABLE SPECIFY RISER OR PLENUM WCW Composite Cable PN# Chord-AC-A-PL NON-EXTENDED CABLE		
Y-1	4-Cond. #22 AWG/STRD/NO SHIELD	WCW#444381-PL
Y-2	8-Cond. #18 AWG/STRD/SHLD W/DRAIN	WCW#002352-PL
Y-3	6-Cond. #18 AWG/STRD/NO SHIELD	WCW#U002391-04-PL
Y-4	4-Cond. #18 AWG/STRD/NO SHIELD	WCW#442380-PL
P	2-COND. #18 AWG 1 PAIR 22 AWG Shielded	WCW-92ELEMPLNTY
X- WCW COMPOSITE CABLE SPECIFY RISER OR PLENUM WCW Composite Cable PN# Chord-AC-A-EXT-PL EXTENDED CABLE		
X-1	4-Cond. #22 AWG/STRD/NO SHIELD	WCW#444381-PL
X-2	8-Cond. #18 AWG/STRD/SHLD W/DRAIN	WCW#002352-PL
X-3	6-Cond. #18 AWG/STRD/NO SHIELD	WCW#U002391-04-PL
X-4	4-Cond. #16 AWG/STRD/NO SHIELD	WCW#991380-PL
P	2-COND. #18 AWG 1 PAIR 22 AWG Shielded	WCW-92ELEMPLNTY

Project Name and Address

Univ of Miami
Device Elevation
SHOP DWG: DD-10

KEYED NOTES:

- ① CONCEALED DOOR POSITION SENSOR INCLUDED IN AD-400 KIT
- ② AD-400-CY-70-MS-8AT ATH-PD (BY DIV 28)
- ③ SURFACE BOLT (BY DIV 8)

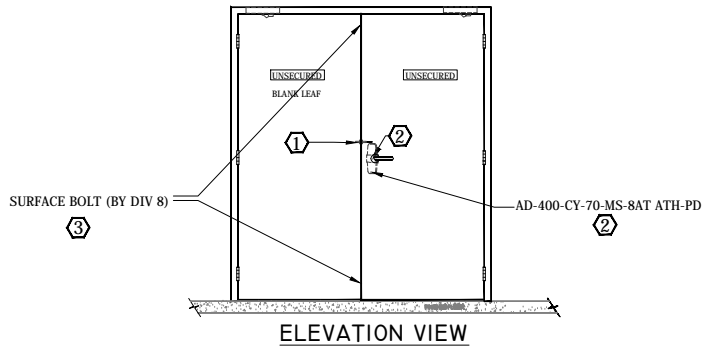
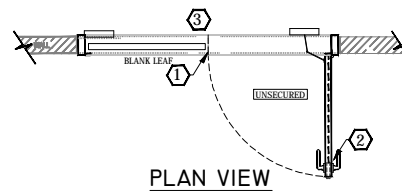

HW-49 Hardware Group No. 49
Not to Scale

HARDWARE GROUPS BASED ON
UMBS 087100 DOOR HARDWARE
STANDARDS 2017 EDITION

GENERAL NOTES
CABLE SCHEDULE

DESIGNATION	DEVICE	CABLE CONFIGURATION
Y1	DPS	4-COND. 22 AWG NO SHIELD
Y2	CR	8-COND. 18 AWG SHIELDED W/DRAIN
Y3	RX	6-COND. 18 AWG SHIELDED NO SHIELD
Y4	EL	4-COND. 18 AWG SHIELDED NO SHIELD
Y	CR-DPS- RX-EL	COMPOSITE CABLE
P	PIM	2-CONDUCTOR 18 AWG 1 PAIR 22 AWG Shielded
P	AD-300	2-CONDUCTOR 18 AWG 1 PAIR 22 AWG Shielded
P	NDE	2-CONDUCTOR 18 AWG 1 PAIR 22 AWG Shielded
AD-WL	AD-400	WIRELESS LOCK

COMPONENT LEGEND

CR	CARD READER
DPS	DOOR POSITION SWITCH
RX	REQUEST TO EXIT
LX	LATCH BOLT MONITOR
EX	ELECTRIC EXIT DEVICE
ES	ELECTRIC STRIKE
PT	ELECTRIC PASS THROUGH DEVICE
PIM	PIM-16-485
AD-400	AD-400 WIRELESS LOCK
AD-300	AD-300 HARDWIRED LOCK
NDE	NDE WIRELESS LOCK
ES	ELECTRIC HARDWARE POWER SUPPLY
ADA	HANDICAP OPERATOR (TYPICAL)
PP	HANDICAP PUSH PLATE (TYPICAL)

CABLE DESCRIPTION

Y- WCW COMPOSITE CABLE SPECIFY RISER OR PLENUM WCW Composite Cable PN# Chord-AC-A-PL NON-EXTENDED CABLE		
Y-1	4-Cond. #22 AWG/STRD/NO SHIELD	WCW#444381-PL
Y-2	8-Cond. #18 AWG/STRD/SHLD W/DRAIN	WCW#002352-PL
Y-3	6-Cond. #18 AWG/STRD/NO SHIELD	WCW#U002391-04-PL
Y-4	4-Cond. #18 AWG/STRD/NO SHIELD	WCW#442380-PL
P	2-COND. #18 AWG 1 PAIR 22 AWG Shielded	WCW-92ELEMPLNTY
X- WCW COMPOSITE CABLE SPECIFY RISER OR PLENUM WCW Composite Cable PN# Chord-AC-A-EXT-PL EXTENDED CABLE		
X-1	4-Cond. #22 AWG/STRD/NO SHIELD	WCW#444381-PL
X-2	8-Cond. #18 AWG/STRD/SHLD W/DRAIN	WCW #002352-PL
X-3	6-Cond. #18 AWG/STRD/NO SHIELD	WCW#U002391-04-PL
X-4	4-Cond. #16 AWG/STRD/NO SHIELD	WCW#991380-PL
P	2-COND. #18 AWG 1 PAIR 22 AWG Shielded	WCW-92ELEMPLNTY

Project Name and Address

Univ of Miami
Device Elevation
SHOP DWG: DD-11

KEYED NOTES:

- ① AD-400-993R-70-MS-ATH-PD (BY DIV 28)
- ② EXIT DEVICE RX-LC-98-EO-F-SNB (BY DIV 8)

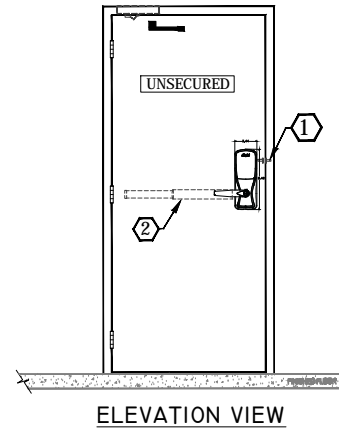
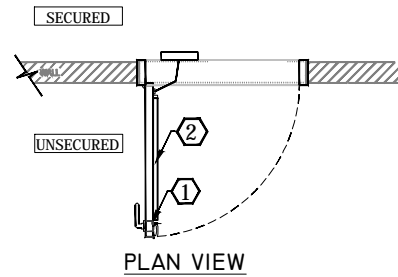

HW-50 Hardware Group No. 50
Not to Scale

HARDWARE GROUPS BASED ON
UMBS 087100 DOOR HARDWARE
STANDARDS 2017 EDITION

GENERAL NOTES
CABLE SCHEDULE

DESIGNATION	DEVICE	CABLE CONFIGURATION
Y1	DPS	4-COND. 22 AWG NO SHIELD
Y2	CR	8-COND. 18 AWG SHIELDED W/DRAIN
Y3	RX	6-COND. 18 AWG SHIELDED NO SHIELD
Y4	EL	4-COND. 18 AWG SHIELDED NO SHIELD
Y	CR- DPS- RX- EL	COMPOSITE CABLE
P	PIM	2-CONDUCTOR 18 AWG 1 PAIR 22 AWG Shielded
P	AD-300	2-CONDUCTOR 18 AWG 1 PAIR 22 AWG Shielded
P	NDE	2-CONDUCTOR 18 AWG 1 PAIR 22 AWG Shielded
AD-WL	AD-400	WIRELESS LOCK

COMPONENT LEGEND

	CARD READER
	DOOR POSITION SWITCH
	REQUEST TO EXIT
	LATCH BOLT MONITOR
	ELECTRIC EXIT DEVICE
	ELECTRIC STRIKE
	ELECTRIC PASS THROUGH DEVICE
	PIM-16-485
	AD-400 WIRELESS LOCK
	AD-300 HARDWIRED LOCK
	NDE WIRELESS LOCK
	ELECTRIC HARDWARE POWER SUPPLY
	HANDICAP OPERATOR (TYPICAL)
	HANDICAP PUSH PLATE (TYPICAL)

CABLE DESCRIPTION

Y- WCW COMPOSITE CABLE
SPECIFY RISER OR PLENUM
WCW Composite Cable
PN# Chord-AC-A-PL

NON- EXTENDED CABLE

Y-1	4-Cond. #22 AWG/STRD/NO SHIELD	WCW#444381-PL
Y-2	8-Cond. #18 AWG/STRD/SHLD/w/DRAIN	WCW#002352-PL
Y-3	6-Cond. #18 AWG/STRD/NO SHIELD	WCW#U002391-04-PL
Y-4	4-Cond. #18 AWG/STRD/NO SHIELD	WCW#442380-PL
P	2-COND.#18 AWG 1 PAIR 22 AWG Shielded	WCW-92ELEMPLNTY

X- WCW COMPOSITE CABLE
SPECIFY RISER OR PLENUM
WCW Composite Cable
PN# Chord-AC-A-EXT-PL

EXTENDED CABLE

X-1	4-Cond. #22 AWG/STRD/NO SHIELD	WCW#444381-PL
X-2	8-Cond. #18 AWG/STRD/SHLD/w/DRAIN	WCW#002352-PL
X-3	6-Cond. #18 AWG/STRD/NO SHIELD	WCW#U002391-04-PL
X-4	4-Cond. #18 AWG/STRD/NO SHIELD	WCW#991380-PL
P	2-COND.#18 AWG 1 PAIR 22 AWG Shielded	WCW-92ELEMPLNTY

Project Name and Address

Univ of Miami
Device Elevation
SHOP DWG: SD-31

KEYED NOTES:

- ① AD-400-993R-70-MS-ATH-PD (BY DIV 28)
- ② EXIT DEVICE RX-LC-98-EO-F-SNB (BY DIV 8)

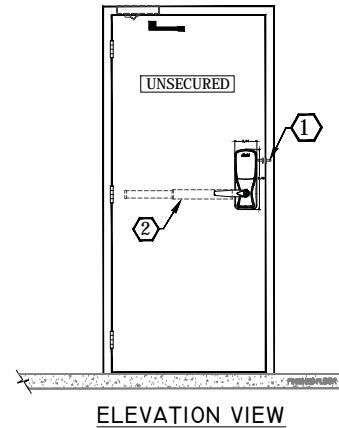
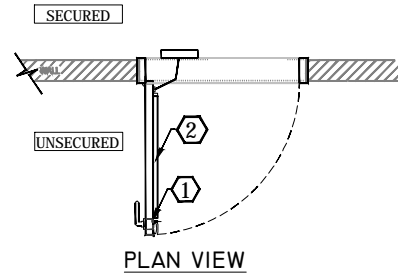

HW-51 Hardware Group No. 51
Not to Scale

HARDWARE GROUPS BASED ON
UMBS 087100 DOOR HARDWARE
STANDARDS 2017 EDITION

GENERAL NOTES		
CABLE SCHEDULE		
DESIGNATION	DEVICE	CABLE CONFIGURATION
Y1	DPS	4-COND. 22 AWG NO SHIELD
Y2	CR	8-COND. 18 AWG SHIELDED W/DRAIN
Y3	RX	6-COND. 18 AWG SHIELDED NO SHIELD
Y4	EL	4-COND. 18 AWG SHIELDED NO SHIELD
Y	CR- DPS- RX- EL	COMPOSITE CABLE
P	PIM	2-CONDUCTOR 18 AWG 1 PAIR 22 AWG Shielded
P	AD-300	2-CONDUCTOR 18 AWG 1 PAIR 22 AWG Shielded
P	NDE	2-CONDUCTOR 18 AWG 1 PAIR 22 AWG Shielded
AD-WL	AD-400	WIRELESS LOCK
COMPONENT LEGEND		
	CARD READER	
	DOOR POSITION SWITCH	
	REQUEST TO EXIT	
	LATCH BOLT MONITOR	
	ELECTRIC EXIT DEVICE	
	ELECTRIC STRIKE	
	ELECTRIC PASS THROUGH DEVICE	
	PIM-16-485	
	AD-400 WIRELESS LOCK	
	AD-300 HARDWIRED LOCK	
	NDE WIRELESS LOCK	
	ELECTRIC HARDWARE POWER SUPPLY	
	HANDICAP OPERATOR (TYPICAL)	
	HANDICAP PUSH PLATE (TYPICAL)	
CABLE DESCRIPTION		
Y- WCW COMPOSITE CABLE SPECIFY RISER OR PLENUM WCW Composite Cable PN# Chord-AC-A-PL		
NON- EXTENDED CABLE		
Y-1	4-Cond. #22 AWG/STRD/NO SHIELD	WCW#444381-PL
Y-2	8-Cond. #18 AWG/STRD/SHLD/w/DRAIN	WCW#002352-PL
Y-3	6-Cond. #18 AWG/STRD/NO SHIELD	WCW#U002391-04-PL
Y-4	4-Cond. #18 AWG/STRD/NO SHIELD	WCW#442380-PL
P	2-COND.#18 AWG 1 PAIR 22 AWG Shielded	WCW-92ELEMPLNTY
X- WCW COMPOSITE CABLE SPECIFY RISER OR PLENUM WCW Composite Cable PN# Chord-AC-A-EXT-PL		
EXTENDED CABLE		
X-1	4-Cond. #22 AWG/STRD/NO SHIELD	WCW#444381-PL
X-2	8-Cond. #18 AWG/STRD/SHLD/w/DRAIN	WCW#002352-PL
X-3	6-Cond. #18 AWG/STRD/NO SHIELD	WCW#U002391-04-PL
X-4	4-Cond. #18 AWG/STRD/NO SHIELD	WCW#991380-PL
P	2-COND.#18 AWG 1 PAIR 22 AWG Shielded	WCW-92ELEMPLNTY

Project Name and Address
Univ of Miami
Device Elevation
SHOP DWG: SD-32

KEYED NOTES:

- ① CONCEALED DOOR POSITION SENSOR INCLUDED IN AD-400 KIT
- ② AD-400-CY-70-MS-8AT ATH-PD (BY DIV 28)
- ③ SURFACE BOLT (BY DIV 8)

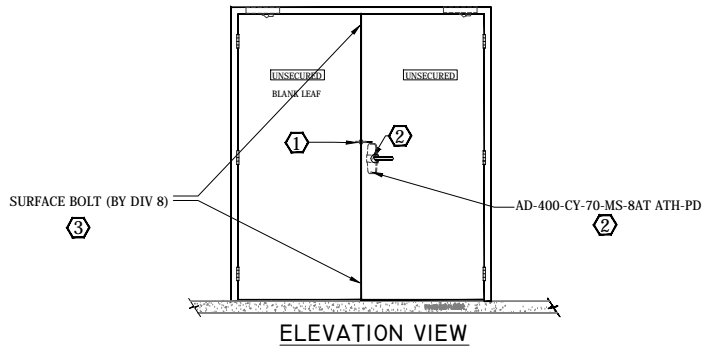
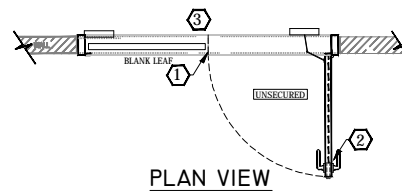

HW-52 Hardware Group No. 52
Not to Scale

HARDWARE GROUPS BASED ON
UMBS 087100 DOOR HARDWARE
STANDARDS 2017 EDITION

GENERAL NOTES
CABLE SCHEDULE

DESIGNATION	DEVICE	CABLE CONFIGURATION
Y1	DPS	4-COND. 22 AWG NO SHIELD
Y2	CR	8-COND. 18 AWG SHIELED W/DRAIN
Y3	RX	6-COND. 18 AWG SHIELED NO SHIELD
Y4	EL	4-COND. 18 AWG SHIELED NO SHIELD
Y	CR-DPS- RX-EL	COMPOSITE CABLE
P	PIM	2-CONDUCTOR 18 AWG 1 PAIR 22 AWG Shielded
P	AD-300	2-CONDUCTOR 18 AWG 1 PAIR 22 AWG Shielded
P	NDE	2-CONDUCTOR 18 AWG 1 PAIR 22 AWG Shielded
AD-WL	AD-400	WIRELESS LOCK

COMPONENT LEGEND

CR	CARD READER
DPS	DOOR POSITION SWITCH
RX	REQUEST TO EXIT
LX	LATCH BOLT MONITOR
EX	ELECTRIC EXIT DEVICE
ES	ELECTRIC STRIKE
PT	ELECTRIC PASS THROUGH DEVICE
PIM	PIM-16-485
AD-400	AD-400 WIRELESS LOCK
AD-300	AD-300 HARDWIRED LOCK
NDE	NDE WIRELESS LOCK
ES	ELECTRIC HARDWARE POWER SUPPLY
ADA	HANDICAP OPERATOR (TYPICAL)
PP	HANDICAP PUSH PLATE (TYPICAL)

CABLE DESCRIPTION

Y- WCW COMPOSITE CABLE SPECIFY RISER OR PLENUM WCW Composite Cable PN# Chord-AC-A-PL NON-EXTENDED CABLE	
Y-1	4-Cond. #22 AWG/STRD/NO SHIELD WCV#444381-PL
Y-2	8-Cond. #18 AWG/STRD/SHLD W/DRAIN WCV#002352-PL
Y-3	6-Cond. #18 AWG/STRD/NO SHIELD WCV#U002391-04-PL
Y-4	4-Cond. #18 AWG/STRD/NO SHIELD WCV#442380-PL
P	2-COND. #18 AWG 1 PAIR 22 AWG Shielded WCV-92ELEMPLNTY
X- WCW COMPOSITE CABLE SPECIFY RISER OR PLENUM WCW Composite Cable PN# Chord-AC-A-EXT-PL EXTENDED CABLE	
X-1	4-Cond. #22 AWG/STRD/NO SHIELD WCV#444381-PL
X-2	8-Cond. #18 AWG/STRD/SHLD W/DRAIN WCV #002352-PL
X-3	6-Cond. #18 AWG/STRD/NO SHIELD WCV#U002391-04-PL
X-4	4-Cond. #16 AWG/STRD/NO SHIELD WCV#991380-PL
P	2-COND. #18 AWG 1 PAIR 22 AWG Shielded WCV-92ELEMPLNTY

Project Name and Address

Univ of Miami
Device Elevation
SHOP DWG: DD-12

KEYED NOTES:

- ① CONCEALED DOOR POSITION SENSOR INCLUDED IN AD-400 KIT
- ② AD-400-CY-70-MS-ATH-PD (BY DIV 28)

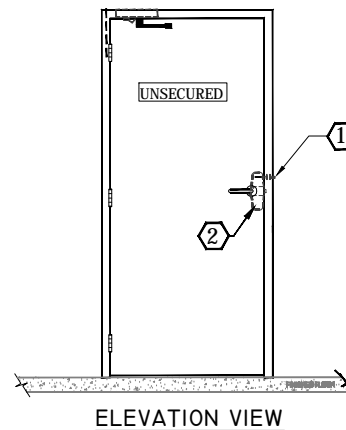
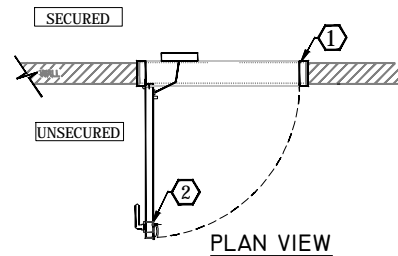

HW-55 Hardware Group No. 55
Not to Scale

HARDWARE GROUPS BASED ON
UMBS 087100 DOOR HARDWARE
STANDARDS 2017 EDITION

GENERAL NOTES
CABLE SCHEDULE

DESIGNATION	DEVICE	CABLE CONFIGURATION
Y1	DPS	4-COND. 22 AWG NO SHIELD
Y2	CR	8-COND. 18 AWG SHIELDED W/DRAIN
Y3	RX	6-COND. 18 AWG SHIELDED NO SHIELD
Y4	EL	4-COND. 18 AWG SHIELDED NO SHIELD
Y	CR-DPS-RX-EL	COMPOSITE CABLE
P	PIM	2-CONDUCTOR 18 AWG 1 PAIR 22 AWG Shielded
P	AD-300	2-CONDUCTOR 18 AWG 1 PAIR 22 AWG Shielded
P	NDE	2-CONDUCTOR 18 AWG 1 PAIR 22 AWG Shielded
AD-WL	AD-400	WIRELESS LOCK

COMPONENT LEGEND	
CR	CARD READER
DPS	DOOR POSITION SWITCH
EX	REQUEST TO EXIT
LX	LATCH BOLT MONITOR
EL	ELECTRIC EXIT DEVICE
ES	ELECTRIC STRIKE
PT	ELECTRIC PASS THROUGH DEVICE
PIM	PIM-16-485
AD-400	AD-400 WIRELESS LOCK
AD-300	AD-300 HARDWIRED LOCK
NDE	NDE WIRELESS LOCK
ES	ELECTRIC HARDWARE POWER SUPPLY
ADA	HANDICAP OPERATOR (TYPICAL)
EP	HANDICAP PUSH PLATE (TYPICAL)

CABLE DESCRIPTION		
Y- WCW COMPOSITE CABLE SPECIFY RISER OR PLENUM WCW Composite Cable PN# Cbord-AC-A-PL		
NON-EXTENDED CABLE		
Y-1	4-Cond. #22 AWG/STRD/NO SHIELD	WCW#444381-PL
Y-2	8-Cond. #18 AWG/STRD/SHLD/w/DRAIN	WCW#002352-PL
Y-3	6-Cond. #18 AWG/STRD/NO SHIELD	WCW#1002391-04-PL
Y-4	4-Cond. #18 AWG/STRD/NO SHIELD	WCW#442380-PL
P	2-COND.#18 AWG 1 PAIR 22 AWG Shielded	WCW-92ELEMPLNTY
X- WCW COMPOSITE CABLE SPECIFY RISER OR PLENUM WCW Composite Cable PN# Cbord-AC-A-EXT-PL		
EXTENDED CABLE		
X-1	4-Cond. #22 AWG/STRD/NO SHIELD	WCW#444381-PL
X-2	8-Cond. #18 AWG/STRD/SHLD/w/DRAIN	WCW#002352-PL
X-3	6-Cond. #18 AWG/STRD/NO SHIELD	WCW#1002391-04-PL
X-4	4-Cond. #18 AWG/STRD/NO SHIELD	WCW#991380-PL
P	2-COND.#18 AWG 1 PAIR 22 AWG Shielded	WCW-92ELEMPLNTY

Project Name and Address
Univ of Miami
Device Elevation
SHOP DWG: SD-33

KEYED NOTES:

- ① CONCEALED DOOR POSITION SENSOR INCLUDED IN AD-400 KIT
- ② AD-400-CY-70-MS-ATH-PD (BY DIV 28)

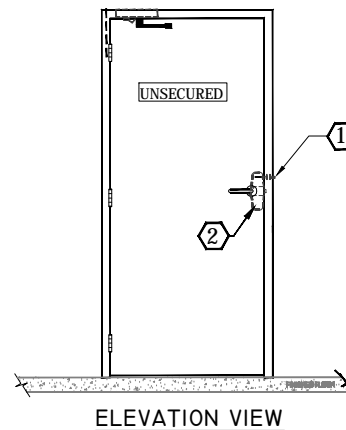
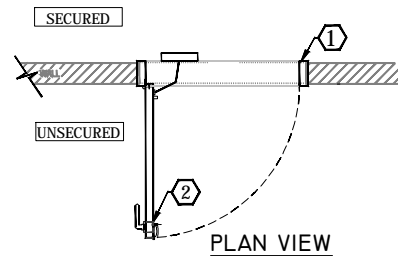

HW-56 Hardware Group No. 56
Not to Scale

HARDWARE GROUPS BASED ON
UMBS 087100 DOOR HARDWARE
STANDARDS 2017 EDITION

GENERAL NOTES
CABLE SCHEDULE

DESIGNATION	DEVICE	CABLE CONFIGURATION
Y1	DPS	4-COND. 22 AWG NO SHIELD
Y2	CR	8-COND. 18 AWG SHIELDED W/DRAIN
Y3	RX	6-COND. 18 AWG SHIELDED NO SHIELD
Y4	EL	4-COND. 18 AWG SHIELDED NO SHIELD
Y	CR-DPS-RX-EL	COMPOSITE CABLE
P	PIM	2-CONDUCTOR 18 AWG 1 PAIR 22 AWG Shielded
P	AD-300	2-CONDUCTOR 18 AWG 1 PAIR 22 AWG Shielded
P	NDE	2-CONDUCTOR 18 AWG 1 PAIR 22 AWG Shielded
AD-WL	AD-400	WIRELESS LOCK

COMPONENT LEGEND	
CR	CARD READER
DPS	DOOR POSITION SWITCH
EX	REQUEST TO EXIT
LX	LATCH BOLT MONITOR
EL	ELECTRIC EXIT DEVICE
ES	ELECTRIC STRIKE
PT	ELECTRIC PASS THROUGH DEVICE
PIM	PIM-16-485
AD-400	AD-400 WIRELESS LOCK
AD-300	AD-300 HARDWIRED LOCK
NDE	NDE WIRELESS LOCK
ES	ELECTRIC HARDWARE POWER SUPPLY
ADA	HANDICAP OPERATOR (TYPICAL)
EP	HANDICAP PUSH PLATE (TYPICAL)

CABLE DESCRIPTION		
Y- WCW COMPOSITE CABLE SPECIFY RISER OR PLENUM WCW Composite Cable PN# Cbord-AC-A-PL		
NON-EXTENDED CABLE		
Y-1	4-Cond. #22 AWG/STRD/NO SHIELD	WCW#444381-PL
Y-2	8-Cond. #18 AWG/STRD/SHLD/w/DRAIN	WCW#002352-PL
Y-3	6-Cond. #18 AWG/STRD/NO SHIELD	WCW#1002391-04-PL
Y-4	4-Cond. #18 AWG/STRD/NO SHIELD	WCW#442380-PL
P	2-COND.#18 AWG 1 PAIR 22 AWG Shielded	WCW-92ELEMPLNTY
X- WCW COMPOSITE CABLE SPECIFY RISER OR PLENUM WCW Composite Cable PN# Cbord-AC-A-EXT-PL		
EXTENDED CABLE		
X-1	4-Cond. #22 AWG/STRD/NO SHIELD	WCW#444381-PL
X-2	8-Cond. #18 AWG/STRD/SHLD/w/DRAIN	WCW#002352-PL
X-3	6-Cond. #18 AWG/STRD/NO SHIELD	WCW#1002391-04-PL
X-4	4-Cond. #18 AWG/STRD/NO SHIELD	WCW#991380-PL
P	2-COND.#18 AWG 1 PAIR 22 AWG Shielded	WCW-92ELEMPLNTY

Project Name and Address
Univ of Miami
Device Elevation
SHOP DWG: SD-34

KEYED NOTES:

- ① CONCEALED DOOR POSITION SENSOR INCLUDED IN NDE80PD KIT
- ② NDE80PD ATH WIRESS LOCK (BY DIV 28)

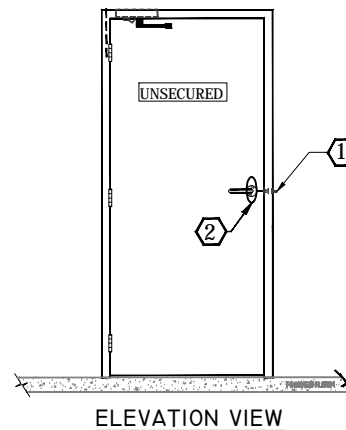
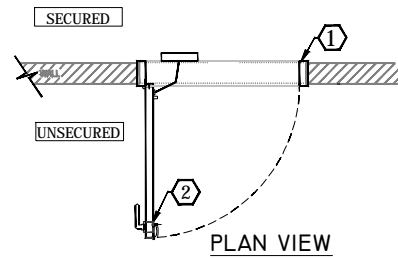

HW-57 Hardware Group No. 57
Not to Scale

HARDWARE GROUPS BASED ON
UMBS 087100 DOOR HARDWARE
STANDARDS 2017 EDITION

GENERAL NOTES
CABLE SCHEDULE

DESIGNATION	DEVICE	CABLE CONFIGURATION
Y1	DPS	4-COND. 22 AWG NO SHIELD
Y2	CR	8-COND. 18 AWG SHIELDED W/DRAIN
Y3	RX	6-COND. 18 AWG SHIELDED NO SHIELD
Y4	EL	4-COND. 18 AWG SHIELDED NO SHIELD
Y	CR-DPS-RX-EL	COMPOSITE CABLE
P	PIM	2-CONDUCTOR 18 AWG 1 PAIR 22 AWG Shielded
P	AD-300	2-CONDUCTOR 18 AWG 1 PAIR 22 AWG Shielded
P	NDE	2-CONDUCTOR 18 AWG 1 PAIR 22 AWG Shielded
AD-WL	AD-400	WIRELESS LOCK

COMPONENT LEGEND	
CR	CARD READER
DPS	DOOR POSITION SWITCH
EX	REQUEST TO EXIT
LX	LATCH BOLT MONITOR
EL	ELECTRIC EXIT DEVICE
ES	ELECTRIC STRIKE
PT	ELECTRIC PASS THROUGH DEVICE
PIM	PIM-16-485
AD-400	AD-400 WIRELESS LOCK
AD-300	AD-300 HARDWIRED LOCK
NDE	NDE WIRELESS LOCK
ES	ELECTRIC HARDWARE POWER SUPPLY
ADA	HANDICAP OPERATOR (TYPICAL)
PP	HANDICAP PUSH PLATE (TYPICAL)

CABLE DESCRIPTION		
Y- WCW COMPOSITE CABLE SPECIFY RISER OR PLENUM WCW Composite Cable PN# Cbord-AC-A-PL		
NON-EXTENDED CABLE		
Y-1	4-Cond. #22 AWG/STRD/NO SHIELD	WCW#444381-PL
Y-2	8-Cond. #18 AWG/STRD/SHLD/w/DRAIN	WCW#002352-PL
Y-3	6-Cond. #18 AWG/STRD/NO SHIELD	WCW#1002391-04-PL
Y-4	4-Cond. #18 AWG/STRD/NO SHIELD	WCW#442380-PL
P	2-COND.#18 AWG 1 PAIR 22 AWG Shielded	WCW-92ELEMPLNTY
X- WCW COMPOSITE CABLE SPECIFY RISER OR PLENUM WCW Composite Cable PN# Cbord-AC-A-EXT-PL		
EXTENDED CABLE		
X-1	4-Cond. #22 AWG/STRD/NO SHIELD	WCW#444381-PL
X-2	8-Cond. #18 AWG/STRD/SHLD/w/DRAIN	WCW#002352-PL
X-3	6-Cond. #18 AWG/STRD/NO SHIELD	WCW#1002391-04-PL
X-4	4-Cond. #18 AWG/STRD/NO SHIELD	WCW#991380-PL
P	2-COND.#18 AWG 1 PAIR 22 AWG Shielded	WCW-92ELEMPLNTY

Project Name and Address
Univ of Miami
Device Elevation
SHOP DWG: SD-35

KEYED NOTES:

- ① CONCEALED DOOR POSITION SENSOR INCLUDED IN NDE80PD KIT
- ② NDE80PD ATH WIRESS LOCK (BY DIV 28)

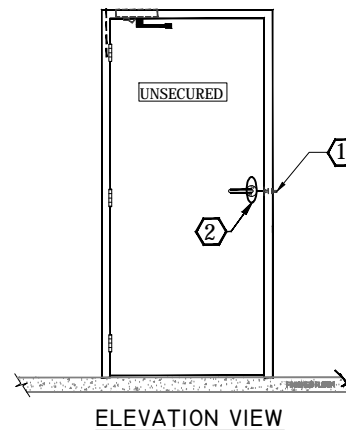
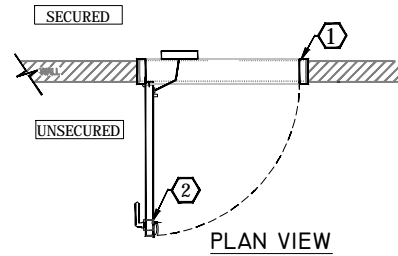

HW-58 Hardware Group No. 58
Not to Scale

HARDWARE GROUPS BASED ON
UMBS 087100 DOOR HARDWARE
STANDARDS 2017 EDITION

GENERAL NOTES
CABLE SCHEDULE

DESIGNATION	DEVICE	CABLE CONFIGURATION
Y1	DPS	4-COND. 22 AWG NO SHIELD
Y2	CR	8-COND. 18 AWG SHIELDED W/DRAIN
Y3	RX	6-COND. 18 AWG SHIELDED NO SHIELD
Y4	EL	4-COND. 18 AWG SHIELDED NO SHIELD
Y	CR-DPS-RX-EL	COMPOSITE CABLE
P	PIM	2-CONDUCTOR 18 AWG 1 PAIR 22 AWG Shielded
P	AD-300	2-CONDUCTOR 18 AWG 1 PAIR 22 AWG Shielded
P	NDE	2-CONDUCTOR 18 AWG 1 PAIR 22 AWG Shielded
AD-WL	AD-400	WIRELESS LOCK

COMPONENT LEGEND	
CR	CARD READER
DPS	DOOR POSITION SWITCH
EX	REQUEST TO EXIT
LX	LATCH BOLT MONITOR
EL	ELECTRIC EXIT DEVICE
ES	ELECTRIC STRIKE
PT	ELECTRIC PASS THROUGH DEVICE
PIM	PIM-16-485
AD-400	AD-400 WIRELESS LOCK
AD-300	AD-300 HARDWIRED LOCK
NDE	NDE WIRELESS LOCK
ES	ELECTRIC HARDWARE POWER SUPPLY
ADA	HANDICAP OPERATOR (TYPICAL)
PP	HANDICAP PUSH PLATE (TYPICAL)

CABLE DESCRIPTION		
Y- WCW COMPOSITE CABLE SPECIFY RISER OR PLENUM WCW Composite Cable PN# Cbord-AC-A-PL		
NON-EXTENDED CABLE		
Y-1	4-Cond. #22 AWG/STRD/NO SHIELD	WCW#444381-PL
Y-2	8-Cond. #18 AWG/STRD/SHLD/w/DRAIN	WCW#002352-PL
Y-3	6-Cond. #18 AWG/STRD/NO SHIELD	WCW#1002391-04-PL
Y-4	4-Cond. #18 AWG/STRD/NO SHIELD	WCW#442380-PL
P	2-COND.#18 AWG 1 PAIR 22 AWG Shielded	WCW-92ELEMPLNTY
X- WCW COMPOSITE CABLE SPECIFY RISER OR PLENUM WCW Composite Cable PN# Cbord-AC-A-EXT-PL		
EXTENDED CABLE		
X-1	4-Cond. #22 AWG/STRD/NO SHIELD	WCW#444381-PL
X-2	8-Cond. #18 AWG/STRD/SHLD/w/DRAIN	WCW#002352-PL
X-3	6-Cond. #18 AWG/STRD/NO SHIELD	WCW#1002391-04-PL
X-4	4-Cond. #18 AWG/STRD/NO SHIELD	WCW#991380-PL
P	2-COND.#18 AWG 1 PAIR 22 AWG Shielded	WCW-92ELEMPLNTY

Project Name and Address
Univ of Miami
Device Elevation
SHOP DWG: SD-36

KEYED NOTES:

- ① CONCEALED DOOR POSITION SENSOR INCLUDED IN NDE80PD KIT
- ② NDE80PD ATH WIRESS LOCK (BY DIV 28)

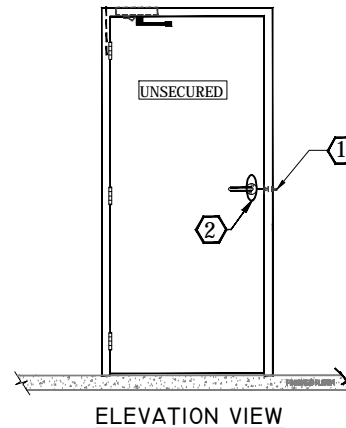
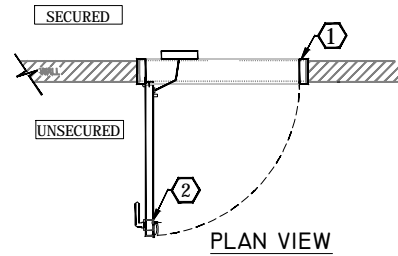

HW-59 Hardware Group No. 59
Not to Scale

HARDWARE GROUPS BASED ON
UMBS 087100 DOOR HARDWARE
STANDARDS 2017 EDITION

GENERAL NOTES
CABLE SCHEDULE

DESIGNATION	DEVICE	CABLE CONFIGURATION
Y1	DPS	4-COND. 22 AWG NO SHIELD
Y2	CR	8-COND. 18 AWG SHIELDED W/DRAIN
Y3	RX	6-COND. 18 AWG SHIELDED NO SHIELD
Y4	EL	4-COND. 18 AWG SHIELDED NO SHIELD
Y	CR-DPS-RX-EL	COMPOSITE CABLE
P	PIM	2-CONDUCTOR 18 AWG 1 PAIR 22 AWG Shielded
P	AD-300	2-CONDUCTOR 18 AWG 1 PAIR 22 AWG Shielded
P	NDE	2-CONDUCTOR 18 AWG 1 PAIR 22 AWG Shielded
AD-WL	AD-400	WIRELESS LOCK

COMPONENT LEGEND	
CR	CARD READER
DPS	DOOR POSITION SWITCH
EX	REQUEST TO EXIT
LX	LATCH BOLT MONITOR
EL	ELECTRIC EXIT DEVICE
ES	ELECTRIC STRIKE
PT	ELECTRIC PASS THROUGH DEVICE
PIM	PIM-16-485
AD-400	AD-400 WIRELESS LOCK
AD-300	AD-300 HARDWIRED LOCK
NDE	NDE WIRELESS LOCK
ES	ELECTRIC HARDWARE POWER SUPPLY
ADA	HANDICAP OPERATOR (TYPICAL)
PP	HANDICAP PUSH PLATE (TYPICAL)

CABLE DESCRIPTION		
Y- WCW COMPOSITE CABLE SPECIFY RISER OR PLENUM WCW Composite Cable PN# Cbord-AC-A-PL		
NON-EXTENDED CABLE		
Y-1	4-Cond. #22 AWG/STRD/NO SHIELD	WCW#444381-PL
Y-2	8-Cond. #18 AWG/STRD/SHLD/w/DRAIN	WCW#002352-PL
Y-3	6-Cond. #18 AWG/STRD/NO SHIELD	WCW#1002391-04-PL
Y-4	4-Cond. #18 AWG/STRD/NO SHIELD	WCW#442380-PL
P	2-COND.#18 AWG 1 PAIR 22 AWG Shielded	WCW-92ELEMPLNTY
X- WCW COMPOSITE CABLE SPECIFY RISER OR PLENUM WCW Composite Cable PN# Cbord-AC-A-EXT-PL		
EXTENDED CABLE		
X-1	4-Cond. #22 AWG/STRD/NO SHIELD	WCW#444381-PL
X-2	8-Cond. #18 AWG/STRD/SHLD/w/DRAIN	WCW#002352-PL
X-3	6-Cond. #18 AWG/STRD/NO SHIELD	WCW#1002391-04-PL
X-4	4-Cond. #18 AWG/STRD/NO SHIELD	WCW#991380-PL
P	2-COND.#18 AWG 1 PAIR 22 AWG Shielded	WCW-92ELEMPLNTY

Project Name and Address
Univ of Miami
Device Elevation
SHOP DWG: SD-37

KEYED NOTES:

- ① CONCEALED DOOR POSITION SENSOR INCLUDED IN NDE80PD KIT
- ② NDE80PD ATH WIRESS LOCK (BY DIV 28)

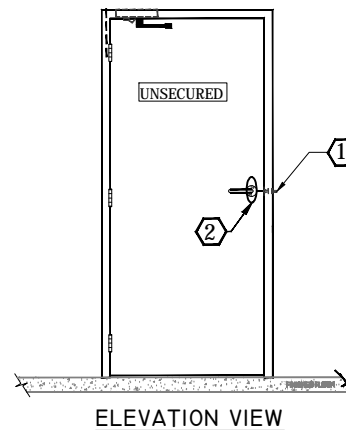
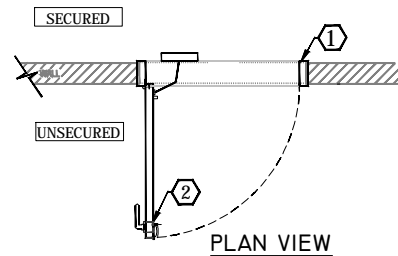

HW-60 Hardware Group No. 60
Not to Scale

HARDWARE GROUPS BASED ON
UMBS 087100 DOOR HARDWARE
STANDARDS 2017 EDITION

**GENERAL NOTES
CABLE SCHEDULE**

DESIGNATION	DEVICE	CABLE CONFIGURATION
Y1	DPS	4-COND. 22 AWG NO SHIELD
Y2	CR	8-COND. 18 AWG SHIELDED W/DRAIN
Y3	RX	6-COND. 18 AWG SHIELDED NO SHIELD
Y4	EL	4-COND. 18 AWG SHIELDED NO SHIELD
Y	CR-DPS-RX-EL	COMPOSITE CABLE
P	PIM	2-CONDUCTOR 18 AWG 1 PAIR 22 AWG Shielded
P	AD-300	2-CONDUCTOR 18 AWG 1 PAIR 22 AWG Shielded
P	NDE	2-CONDUCTOR 18 AWG 1 PAIR 22 AWG Shielded
AD-WL	AD-400	WIRELESS LOCK

COMPONENT LEGEND	
CR	CARD READER
DPS	DOOR POSITION SWITCH
EX	REQUEST TO EXIT
LX	LATCH BOLT MONITOR
EL	ELECTRIC EXIT DEVICE
ES	ELECTRIC STRIKE
PT	ELECTRIC PASS THROUGH DEVICE
PIM	PIM-16-485
AD-400	AD-400 WIRELESS LOCK
AD-300	AD-300 HARDWIRED LOCK
NDE	NDE WIRELESS LOCK
ES	ELECTRIC HARDWARE POWER SUPPLY
ADA	HANDICAP OPERATOR (TYPICAL)
PP	HANDICAP PUSH PLATE (TYPICAL)

CABLE DESCRIPTION		
Y- WCW COMPOSITE CABLE SPECIFY RISER OR PLENUM WCW Composite Cable PN# Cbord-AC-A-PL		
NON-EXTENDED CABLE		
Y-1	4-Cond. #22 AWG/STRD/NO SHIELD	WCW#444381-PL
Y-2	8-Cond. #18 AWG/STRD/SHLD/w/DRAIN	WCW#002352-PL
Y-3	6-Cond. #18 AWG/STRD/NO SHIELD	WCW#1002391-04-PL
Y-4	4-Cond. #18 AWG/STRD/NO SHIELD	WCW#442380-PL
P	2-COND.#18 AWG 1 PAIR 22 AWG Shielded	WCW-92ELEMPLNTY
X- WCW COMPOSITE CABLE SPECIFY RISER OR PLENUM WCW Composite Cable PN# Cbord-AC-A-EXT-PL		
EXTENDED CABLE		
X-1	4-Cond. #22 AWG/STRD/NO SHIELD	WCW#444381-PL
X-2	8-Cond. #18 AWG/STRD/SHLD/w/DRAIN	WCW#002352-PL
X-3	6-Cond. #18 AWG/STRD/NO SHIELD	WCW#1002391-04-PL
X-4	4-Cond. #18 AWG/STRD/NO SHIELD	WCW#991380-PL
P	2-COND.#18 AWG 1 PAIR 22 AWG Shielded	WCW-92ELEMPLNTY

Project Name and Address
**Univ of Miami
Device Elevation
SHOP DWG: SD-38**

KEYED NOTES:

- ① 1" CONDUIT TO ACCESSIBLE CEILING FOR PATHWAY AND WIRING TO SECURITY CONTROL LOCATION. (BY DIV 26)
- ② CONCEALED 6" X 8" X 3" COVERED JUNCTION BOX LOCATED NEAR DOOR ABOVE CEILING ACCESSIBLE TO SECURE SIDE. (BY DIV 26)
- ③ CONCEALED DOOR POSITION SENSOR PROVIDE 3/4" CONDUIT AND REQUIRED FRAME AND PATHWAY PREPARATION (BY DIV 26)
- ④ CONCEALED 1" DOOR POSITION SENSOR 679-05HM (DIV 28)
- ⑤ ELECTRIC STRIKE 6211 FSE (BY DIV 28)
- ⑥ PASSIVE IR REQUEST TO EXIT MOTION SCANII (BY DIV 28)
- ⑦ PROVIDE 3/4" CONDUIT, REQUIRED FRAME AND PATHWAY PREPARATION FOR WIREWAY TO ELECTRIC STRIKE AND PASSIVE INFRARED DETECTOR (BY DIV 26)
- ⑧ MOUNT MTMS15 CARD READER ON UNSECURE SIDE 42" AFF AND 6" OPTIMUM FROM DOOR. (BY DIV 28)
- ⑨ MOUNT CARD READER ON UNSECURE SIDE 42" AFF AND 6" OPTIMUM FROM DOOR. (BY DIV 28)

- ⑩ DOOR HARDWARE POWER SUPPLY. (BY DIV 28)
- ⑪ 120 VAC CIRCUIT (DIV 26).
- ⑫ STORE ROOM LOCK ND96PD ATH

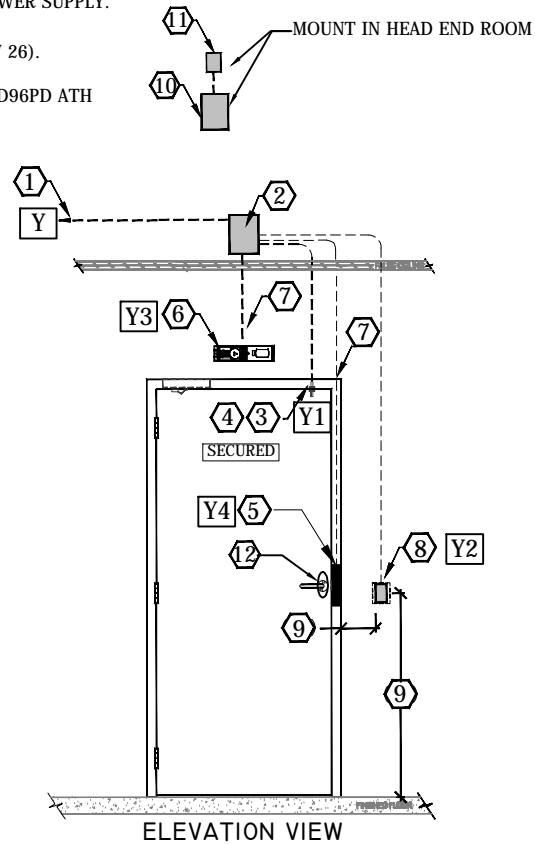

ELEVATION VIEW

HW-62 Hardware Group No. 62
Not to Scale

HARDWARE GROUPS BASED ON
UMBS 087100 DOOR HARDWARE
STANDARDS 2017 EDITION

GENERAL NOTES
CABLE SCHEDULE

DESIGNATION	DEVICE	CABLE CONFIGURATION
Y1	DPS	4-COND. 22 AWG NO SHIELD
Y2	CR	8-COND. 18 AWG SHIELDED W/DRAIN
Y3	RX	6-COND. 18 AWG SHIELDED NO SHIELD
Y4	EL	4-COND. 18 AWG SHIELDED NO SHIELD
Y	CR-DPS-RX-EL	COMPOSITE CABLE
P	PIM	2-CONDUCTOR 18 AWG 1 PAIR 22 AWG Shielded
P	AD-300	2-CONDUCTOR 18 AWG 1 PAIR 22 AWG Shielded
P	NDE	2-CONDUCTOR 18 AWG 1 PAIR 22 AWG Shielded
AD-WL	AD-400	WIRELESS LOCK

COMPONENT LEGEND

CR	CARD READER
DPS	DOOR POSITION SWITCH
EX	REQUEST TO EXIT
EX	LATCH BOLT MONITOR
EL	ELECTRIC EXIT DEVICE
ES	ELECTRIC STRIKE
ET	ELECTRIC PASS THROUGH DEVICE
PIM	PIM-16-485
AD-400	AD-400 WIRELESS LOCK
AD-300	AD-300 HARDWIRED LOCK
NDE	NDE WIRELESS LOCK
ES	ELECTRIC HARDWARE POWER SUPPLY
ADA	HANDICAP OPERATOR (TYPICAL)
EP	HANDICAP PUSH PLATE (TYPICAL)

CABLE DESCRIPTION

Y- WCW COMPOSITE CABLE
SPECIFY RISER OR PLENUM
WCW Composite Cable
PN# Chord-AC-A-PL

NON-EXTENDED CABLE

Y-1	4-Cond. #22 AWG/STRD/NO SHIELD	WCW#444381-PL
Y-2	8-Cond. #18 AWG/STRD/SHLD/w/DRAIN	WCW#002352-PL
Y-3	6-Cond. #18 AWG/STRD/NO SHIELD	WCW#U002391-04-PL
Y-4	4-Cond. #18 AWG/STRD/NO SHIELD	WCW#442380-PL
P	2-COND. #18 AWG 1 PAIR 22 AWG Shielded	WCW-92ELEMPLY

X- WCW COMPOSITE CABLE
SPECIFY RISER OR PLENUM
WCW Composite Cable
PN# Chord-AC-A-EXT-PL

EXTENDED CABLE

X-1	4-Cond. #22 AWG/STRD/NO SHIELD	WCW#444381-PL
X-2	8-Cond. #18 AWG/STRD/SHLD/w/DRAIN	WCW#002352-PL
X-3	6-Cond. #18 AWG/STRD/NO SHIELD	WCW#U002391-04-PL
X-4	4-Cond. #16 AWG/STRD/NO SHIELD	WCW#991380-PL
P	2-COND. #18 AWG 1 PAIR 22 AWG Shielded	WCW-92ELEMPLY

Project Name and Address

Univ of Miami
Device Elevation
SHOP DWG: SD-40

KEYED NOTES:

- ① CONCEALED DOOR POSITION SENSOR INCLUDED IN AD-400 KIT
- ② AD-400-CY-70-MS-ATH-PD (BY DIV 28)

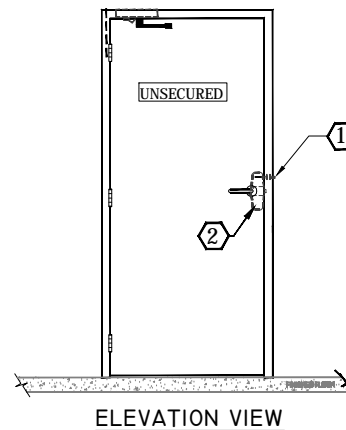
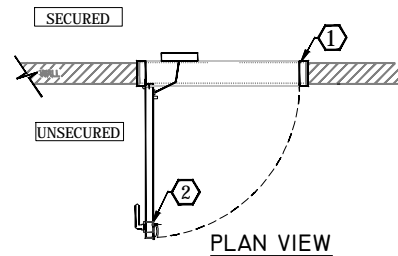

HW-63 Hardware Group No. 63
Not to Scale

HARDWARE GROUPS BASED ON
UMBS 087100 DOOR HARDWARE
STANDARDS 2017 EDITION

GENERAL NOTES
CABLE SCHEDULE

DESIGNATION	DEVICE	CABLE CONFIGURATION
Y1	DPS	4-COND. 22 AWG NO SHIELD
Y2	CR	8-COND. 18 AWG SHIELDED W/DRAIN
Y3	RX	6-COND. 18 AWG SHIELDED NO SHIELD
Y4	EL	4-COND. 18 AWG SHIELDED NO SHIELD
Y	CR-DPS-RX-EL	COMPOSITE CABLE
P	PIM	2-CONDUCTOR 18 AWG 1 PAIR 22 AWG Shielded
P	AD-300	2-CONDUCTOR 18 AWG 1 PAIR 22 AWG Shielded
P	NDE	2-CONDUCTOR 18 AWG 1 PAIR 22 AWG Shielded
AD-WL	AD-400	WIRELESS LOCK

COMPONENT LEGEND	
CR	CARD READER
DPS	DOOR POSITION SWITCH
EX	REQUEST TO EXIT
LX	LATCH BOLT MONITOR
EL	ELECTRIC EXIT DEVICE
ES	ELECTRIC STRIKE
PT	ELECTRIC PASS THROUGH DEVICE
PIM	PIM-16-485
AD-400	AD-400 WIRELESS LOCK
AD-300	AD-300 HARDWIRED LOCK
NDE	NDE WIRELESS LOCK
ES	ELECTRIC HARDWARE POWER SUPPLY
ADA	HANDICAP OPERATOR (TYPICAL)
EP	HANDICAP PUSH PLATE (TYPICAL)

CABLE DESCRIPTION		
Y- WCW COMPOSITE CABLE SPECIFY RISER OR PLENUM WCW Composite Cable PN# Cbord-AC-A-PL		
NON-EXTENDED CABLE		
Y-1	4-Cond. #22 AWG/STRD/NO SHIELD	WCW#444381-PL
Y-2	8-Cond. #18 AWG/STRD/SHLD/w/DRAIN	WCW#002352-PL
Y-3	6-Cond. #18 AWG/STRD/NO SHIELD	WCW#1002391-04-PL
Y-4	4-Cond. #18 AWG/STRD/NO SHIELD	WCW#442380-PL
P	2-COND.#18 AWG 1 PAIR 22 AWG Shielded	WCW-92ELEMPLNTY
X- WCW COMPOSITE CABLE SPECIFY RISER OR PLENUM WCW Composite Cable PN# Cbord-AC-A-EXT-PL		
EXTENDED CABLE		
X-1	4-Cond. #22 AWG/STRD/NO SHIELD	WCW#444381-PL
X-2	8-Cond. #18 AWG/STRD/SHLD/w/DRAIN	WCW#002352-PL
X-3	6-Cond. #18 AWG/STRD/NO SHIELD	WCW#1002391-04-PL
X-4	4-Cond. #18 AWG/STRD/NO SHIELD	WCW#991380-PL
P	2-COND.#18 AWG 1 PAIR 22 AWG Shielded	WCW-92ELEMPLNTY

Project Name and Address
Univ of Miami
Device Elevation
SHOP DWG: SD-41

KEYED NOTES:

- ① CONCEALED DOOR POSITION SENSOR INCLUDED IN AD-400 KIT
- ② AD-400-CY-70-MS-ATH-PD (BY DIV 28)

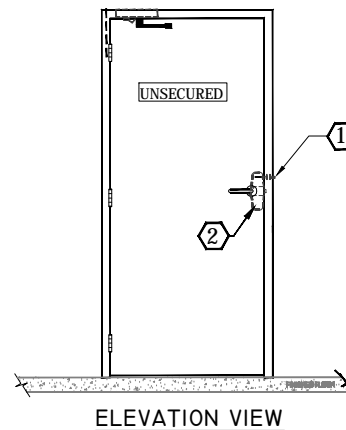
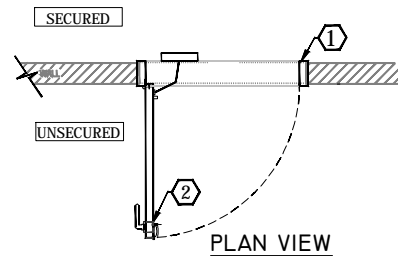

HW-64 Hardware Group No. 64
Not to Scale

HARDWARE GROUPS BASED ON
UMBS 087100 DOOR HARDWARE
STANDARDS 2017 EDITION

GENERAL NOTES
CABLE SCHEDULE

DESIGNATION	DEVICE	CABLE CONFIGURATION
Y1	DPS	4-COND. 22 AWG NO SHIELD
Y2	CR	8-COND. 18 AWG SHIELDED W/DRAIN
Y3	RX	6-COND. 18 AWG SHIELDED NO SHIELD
Y4	EL	4-COND. 18 AWG SHIELDED NO SHIELD
Y	CR-DPS-RX-EL	COMPOSITE CABLE
P	PIM	2-CONDUCTOR 18 AWG 1 PAIR 22 AWG Shielded
P	AD-300	2-CONDUCTOR 18 AWG 1 PAIR 22 AWG Shielded
P	NDE	2-CONDUCTOR 18 AWG 1 PAIR 22 AWG Shielded
AD-WL	AD-400	WIRELESS LOCK

COMPONENT LEGEND	
CR	CARD READER
DPS	DOOR POSITION SWITCH
EX	REQUEST TO EXIT
LX	LATCH BOLT MONITOR
EL	ELECTRIC EXIT DEVICE
ES	ELECTRIC STRIKE
PT	ELECTRIC PASS THROUGH DEVICE
PIM	PIM-16-485
AD-400	AD-400 WIRELESS LOCK
AD-300	AD-300 HARDWIRED LOCK
NDE	NDE WIRELESS LOCK
ES	ELECTRIC HARDWARE POWER SUPPLY
ADA	HANDICAP OPERATOR (TYPICAL)
EP	HANDICAP PUSH PLATE (TYPICAL)

CABLE DESCRIPTION		
Y- WCW COMPOSITE CABLE SPECIFY RISER OR PLENUM WCW Composite Cable PN# Cbord-AC-A-PL		
NON-EXTENDED CABLE		
Y-1	4-Cond. #22 AWG/STRD/NO SHIELD	WCW#444381-PL
Y-2	8-Cond. #18 AWG/STRD/SHLD/w/DRAIN	WCW#002352-PL
Y-3	6-Cond. #18 AWG/STRD/NO SHIELD	WCW#1002391-04-PL
Y-4	4-Cond. #18 AWG/STRD/NO SHIELD	WCW#442380-PL
P	2-COND.#18 AWG 1 PAIR 22 AWG Shielded	WCW-92ELEMPLNTY
X- WCW COMPOSITE CABLE SPECIFY RISER OR PLENUM WCW Composite Cable PN# Cbord-AC-A-EXT-PL		
EXTENDED CABLE		
X-1	4-Cond. #22 AWG/STRD/NO SHIELD	WCW#444381-PL
X-2	8-Cond. #18 AWG/STRD/SHLD/w/DRAIN	WCW#002352-PL
X-3	6-Cond. #18 AWG/STRD/NO SHIELD	WCW#1002391-04-PL
X-4	4-Cond. #18 AWG/STRD/NO SHIELD	WCW#991380-PL
P	2-COND.#18 AWG 1 PAIR 22 AWG Shielded	WCW-92ELEMPLNTY

Project Name and Address
Univ of Miami
Device Elevation
SHOP DWG: SD-42

KEYED NOTES:

- ① CONCEALED DOOR POSITION SENSOR INCLUDED IN AD-400 KIT
- ② AD-400-CY-70-MS-ATH-PD (BY DIV 28)

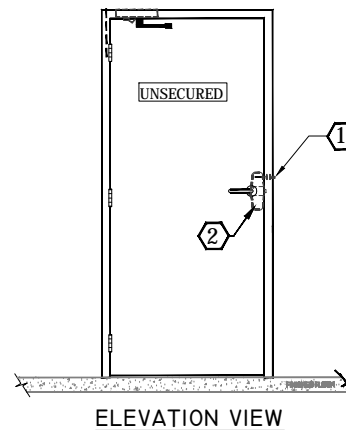
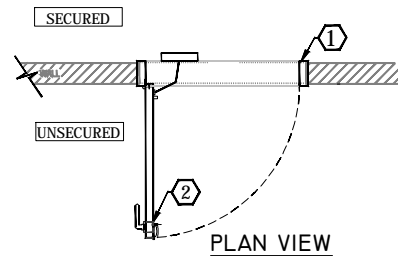

HW-65 Hardware Group No. 65
Not to Scale

HARDWARE GROUPS BASED ON
UMBS 087100 DOOR HARDWARE
STANDARDS 2017 EDITION

GENERAL NOTES
CABLE SCHEDULE

DESIGNATION	DEVICE	CABLE CONFIGURATION
Y1	DPS	4-COND. 22 AWG NO SHIELD
Y2	CR	8-COND. 18 AWG SHIELDED W/DRAIN
Y3	RX	6-COND. 18 AWG SHIELDED NO SHIELD
Y4	EL	4-COND. 18 AWG SHIELDED NO SHIELD
Y	CR-DPS-RX-EL	COMPOSITE CABLE
P	PIM	2-CONDUCTOR 18 AWG 1 PAIR 22 AWG Shielded
P	AD-300	2-CONDUCTOR 18 AWG 1 PAIR 22 AWG Shielded
P	NDE	2-CONDUCTOR 18 AWG 1 PAIR 22 AWG Shielded
AD-WL	AD-400	WIRELESS LOCK

COMPONENT LEGEND	
CR	CARD READER
DPS	DOOR POSITION SWITCH
EX	REQUEST TO EXIT
LX	LATCH BOLT MONITOR
EL	ELECTRIC EXIT DEVICE
ES	ELECTRIC STRIKE
PT	ELECTRIC PASS THROUGH DEVICE
PIM	PIM-16-485
AD-400	AD-400 WIRELESS LOCK
AD-300	AD-300 HARDWIRED LOCK
NDE	NDE WIRELESS LOCK
ES	ELECTRIC HARDWARE POWER SUPPLY
ADA	HANDICAP OPERATOR (TYPICAL)
EP	HANDICAP PUSH PLATE (TYPICAL)

CABLE DESCRIPTION		
Y- WCW COMPOSITE CABLE SPECIFY RISER OR PLENUM WCW Composite Cable PN# Cbord-AC-A-PL		
NON-EXTENDED CABLE		
Y-1	4-Cond. #22 AWG/STRD/NO SHIELD	WCW#444381-PL
Y-2	8-Cond. #18 AWG/STRD/SHLD/w/DRAIN	WCW#002352-PL
Y-3	6-Cond. #18 AWG/STRD/NO SHIELD	WCW#1002391-04-PL
Y-4	4-Cond. #18 AWG/STRD/NO SHIELD	WCW#442380-PL
P	2-COND.#18 AWG 1 PAIR 22 AWG Shielded	WCW-92ELEMPLNTY
X- WCW COMPOSITE CABLE SPECIFY RISER OR PLENUM WCW Composite Cable PN# Cbord-AC-A-EXT-PL		
EXTENDED CABLE		
X-1	4-Cond. #22 AWG/STRD/NO SHIELD	WCW#444381-PL
X-2	8-Cond. #18 AWG/STRD/SHLD/w/DRAIN	WCW#002352-PL
X-3	6-Cond. #18 AWG/STRD/NO SHIELD	WCW#1002391-04-PL
X-4	4-Cond. #18 AWG/STRD/NO SHIELD	WCW#991380-PL
P	2-COND.#18 AWG 1 PAIR 22 AWG Shielded	WCW-92ELEMPLNTY

Project Name and Address
Univ of Miami
Device Elevation
SHOP DWG: SD-43

DIVISION 09 FINISHES

This chapter identifies criteria for the selection of finishes with the purpose of establishing minimum standards, acceptable to UM, to be used as the basis of design for UM Coral Gables Campus Buildings.

- 09.1 General Requirements
 - 09.1.1 Submittals
 - 09.1.2 Workmanship requirements
- 09.2 Codes and Standards
- 09.3 Design Criteria
- 09.4 Specific Requirements (organized by CSI Master Format® 2012 Numbers & Titles)

09.1 General Requirements

Only those sections that are used in typical projects are listed below. Refer to the UM Interior Design Guidelines for specialty type finishes. Finishes shall be selected and specified to comply with the following objectives:

1. Sustainable design, using sustainable products.
 - a. At a minimum, all new facilities and renovations must meet LEED silver standards.
 - b. Avoid products with vinyl or PVC contents, unless approved by the UMBS Committee.
 - c. Low-emitting finish options are preferred. If finishes with chemical emissions cannot be avoided, off-gassing must be completed prior to Substantial Completion.
 - d. Consider design that uses the structure as the finish to reduce material use and environmental impact.
2. Ease of maintenance.
 - a. All finishes must exhibit high durability with low maintenance requirements.
 - b. Avoid materials that require routine sealing or significant specialized maintenance.
 - c. Avoid excessively light, high intensity hues or dark colored finishes (especially black); both are difficult to maintain or have a propensity to fade.
 - d. Shiny, mirror-like surfaces should be avoided; especially where finger contact and transmission of human oils from fingerprints is possible.
 - e. Appropriate materials and abrasion resistance should be considered in high traffic areas;
 - 1) Floor grilles should be placed at entrances to facilities.
 - f. Wall protection and corner guards shall be provided in areas where carts or other items might damage wall surfaces.

3. All specified finishes must have a demonstrated history, of a minimum five years resistance to fade, degradation and reduced service-life, in a similar institutional setting, with similar regularity of cleaning and maintenance.
4. Design selections shall be conservative rather than trendy to reduce the pace of replacement cycles, minimizing the aesthetic associated impact.
5. Avoid custom-designed colors and finish materials.
6. Products with a low life cycle cost (that compares to installed cost, replacement cost, and cleaning/labor costs over an established time period) are preferred.
7. For cost saving purposes for the University, consider finishes that can be purchased through Premier Group Purchasing.
8. Design reviews and approval by University of Miami Building Standard Committee (UMBSC) are required for all finish selections.
9. On renovation projects, all material patches should blend as closely as possible. Low-emitting materials must be used.
10. Construction documents must clearly identify and note all finishes including their extent of coverage.
11. Coordinate requirements for a “maintenance surplus” stock with the UM Project Manager.
12. Prior to installation of floor finish material, concrete slabs shall be smooth and level; maximum surface variations not to exceed 1/8” in a 10 ft. radius. Grind down ridges and other irregularities for intended floor finish. All new and existing concrete floor slabs shall be tested for PH and moisture content compliance with the materials manufacturer’s optimum requirements for prior to installation of said finish. No finishes shall be installed without compliance with PH and moisture requirements.

The design of the interior and exterior finishes, in concert with other building components, shall produce a building that meets the programmed sustainability rating (LEED rating) of the specific project. These objectives are in line with the objectives of all Divisions and should be coordinated with requirements in Division 1 Section “SUSTAINABLE DESIGN REQUIREMENTS.”

09.1.1 Submittals

Submittals shall include product data, samples, sustainability data, shop drawings, coordination drawings, and maintenance materials submittals.

09.1.2 Workmanship requirements

Refer to specific requirements included herein.

09.2 Codes and Standards

1. Florida Building Code.
2. The City of Coral Gables local codes and ordinances.

09.3 Design Criteria

Refer to specific requirements included herein.

09.4 Specific Requirements (organized by CSI Master Format® 2012 Numbers & Titles).

09 22 16	Non-Structural Metal Framing
09 24 00	Portland Cement Plastering
09 26 13	Gypsum Veneer Plastering
09 27 13	Glass-Fiber-Reinforced Plaster Fabrications
09 29 00	Gypsum Board
09 30 00	Tiling
09 30 33	Stone Tiling
09 51 23	Acoustical Ceiling Panels
09 54 23	Linear Metal Ceilings
09 54 36	Suspended Decorative Grids
09 54 43	Stretched-Fabric Ceiling Systems
09 54 46	Fabric-Wrapped Ceiling Panels
09 63 40	Stone Flooring
09 64 00	Wood Flooring
09 64 66	Wood Athletic Flooring
09 65 00	Resilient Flooring, Base and Accessories
09 65 66	Resilient Athletic Flooring
09 66 23	Resinous Matrix Terrazzo Flooring
09 67 23	Resinous Flooring
09 68 00	Sheet Carpeting and Carpet Tiles
09 69 00	Access Flooring
09 72 00	Wall Coverings
09 75 13	Stone Paneling
09 75 16	Stone Base
09 75 19	Stone Trim
09 75 23	Stone Window Stools
09 77 13	Stretched-Fabric Wall Systems
09 77 23	Fabric-Wrapped Panels
09 84 33	Sound-Absorbing Wall Units
09 84 36	Sound-Absorbing Ceiling Units

09 91 00	Interior and Exterior Painting
09 93 00	Staining and Transparent Finishing
09 94 19	Multicolor Interior Finishing
09 96 00	High-Performance Coatings
09 96 33	High-Temperature-Resistant Coatings
09 96 53	Elastomeric Coatings
09 97 26	Cementitious Coatings

09 22 16 Non-Structural Metal Framing

Design Standards

1. The intent of these standards is to provide general guidelines to the design professional on the design, quality of installation and QAQC of the finished materials, assembly and material for both interior and exterior applications on a building. These standards shall not supersede code and regulations nor relieve the design professional from their professional responsibility.
2. Selection of products, applications and products should be preceded by a careful analysis of applicable building codes, building regulations and authorities having jurisdiction. Select approved materials as applicable for insulation, abuse, finishes, impact and fire-resistance designs should be based on applicable industry construction standards and application recommendations from manufacturers.
3. The Design Professional should select materials that are durable and able to cope with South Florida weather conditions. Finishes shall allow for cleaning of graffiti or stains with relative ease for maintenance staff. The design and selection of finishes shall be based on the following:
 1. Vandal resistance.
 2. Cost effectiveness.
 3. Durability
 4. Resistance to crack and peeling
 5. Resistance to fading or discoloration from exposure, abrasion, cleaning and sunlight, weather tightness under normal and hurricane conditions
 6. Absence of excessively rough or sharp textures or features.
4. Studies have shown that materials are a major contributor to “sick building syndrome”. In consequence, building materials used for UMBS shall not contain asbestos, lead, formaldehyde, mercury, volatile organic chemicals (VOCS), or any other determined to be harmful products. Only non-toxic adhesives are to be used.

1. Interior framing systems (e.g., supports for partition walls, framed soffits, furring, etc.).
2. Interior suspension systems (e.g., supports for gypsum ceilings, suspended soffits, etc.).

Performance Standards

1. ASTM C 754, Installation of Steel Framing Members to Receive Screw-Attached Gypsum Wallboard, Backing Board, or Water-Resistant Backer Board.
2. ASTM C 645-08, Standard Specification for Nonstructural Steel Framing Members.
3. ASTM C 1002, Standard Specification Steel Self-Piercing Tapping Screws for the Application of Gypsum Panel Products or Metal Plaster Bases to Wood Studs or Steel Studs.
4. ASTM A 1003, Standard Specification for Steel Sheet, Carbon, Metallic- and Nonmetallic-Coated for Cold-Formed Framing Members.
5. Design Criteria, Walls: The system shall provide a true, flat system to receive the gypsum board.
 1. Board, framing members and spacing shall produce deflections no greater than $L/240$ at a 5.0 psf load.
 2. Control joints shall be spaced: Where indicated, or in no case farther apart than 30 ft.
6. Design Criteria, Ceilings and Soffits: The system shall provide a true, flat system to receive the gypsum board.
 1. Board, framing members and spacing shall produce deflections no greater than $L/240$ at dead load plus-or-minus 5psf vertical force.
 2. Control joints shall be spaced no farther apart than the lesser of:
 - a. The spacing indicated.
 - b. 30 ft. at ceilings without perimeter relief.
 - c. 50 ft. at ceilings with perimeter relief.
 3. Interior Ceiling Suspension System shall be at the Contractor's option:
 - a. Carrying Channel and Cross Furring System, with hangers.
 - b. Screwable Grid System, with hangers.
 - c. Horizontal Stud System, spanning across the area without hangers, where the span across a room is within the span range of the horizontal studs. For standard studs, single spans, stud sizes shall be 2-1/2-inch stud for up to 10 ft. span, 3-5/8-inch stud for up to 13-ft. span, or 4-inch stud for up to 14-ft. span.

Delivery, Storage and Handling

1. Deliver the materials in their original packages, containers, or bundles bearing the brand name and identification of the manufacturer or supplier.
2. Store the materials inside, under cover, and keep them dry and protected against damage from the weather, direct sunlight, surface contamination, corrosion, construction traffic, and other causes of damage.
3. Store and handle the steel framing and related products per the A.I.S.I. "Code of Standard practice".

Product Requirements

1. **Fire-Test-Response Characteristics:** For fire-resistance-rated assemblies that incorporate non-load-bearing steel framing, provide materials and construction identical to those tested in the assembly indicated according to ASTM E 119 by an independent testing agency. Products used in the assembly shall carry a classification label from a testing laboratory acceptable to the authority having jurisdiction.
2. **STC Rated Assemblies:** For STC-rated assemblies that incorporate non-load-bearing steel framing, provide materials and construction identical to those tested in an assembly indicated according to ASTM E 90 and classified according to ASTM E 413 by an independent testing agency.
3. **Framing Members, General:** Comply with ASTM C 754 for conditions indicated.
 1. **Steel Sheet Components:** Comply with ASTM C 645-08 requirements for metal, unless otherwise indicated.
 2. **Protective Coating:** Coating with equivalent corrosion resistance of ASTM A 653, as follows:
 - a. **Typical Interior:** G40, hot-dip galvanized.
4. **Steel Studs and Runners:** ASTM C 645-08. Use either steel studs and runners or dimpled steel studs and runners.
 1. **Minimum Base-Metal Thickness:** As indicated on the Drawings, otherwise:
 - a. **Steel Studs and Runners (non-Dimpled):**
 - 1) **Minimum Base Metal Thickness, Typical:** At least 0.025 inch, 25 gauge.
 - b. **Dimpled Steel Studs and Runners:** Members that can show certified third party testing in accordance with ICC – ES – AC86 that meets ASTM C645-08 Section 9.2.
 - 1) **Minimum Base Metal Thickness, Typical:** As indicated on the Drawings, otherwise:(0.015 inch, 28 gauge, 25 gauge-equivalent.

- 2) Acceptable products include ClarkDietrich “UltraSteel” or ProStud” and “ProTrack” Framing, (Install studs in rated partitions per UL V450 or UL V438 or UL U419.)
5. Slip-Type Head Joints: Where indicated, provide one of the following:
1. Single Long-Leg Runner System: ASTM C 645 top runner with 2-inch-deep flanges in a thickness not less than indicated for studs, installed with the studs friction fit into the top runner and with continuous bridging located within 12 inches of the top of studs to provide lateral bracing.
 2. Double-Runner System: ASTM C 645 top runners, an inside runner with 2-inch-deep flanges in a thickness not less than indicated for the studs and fastened to the studs, and an outer runner sized to friction-fit the inside runner.
 3. Deflection Track: Steel sheet top runner manufactured to prevent cracking of finishes applied to the interior partition framing resulting from deflection of the structure above; in a thickness not less than indicated for the studs and in a width to accommodate the depth of studs.
 - a. Available Products: Subject to compliance with requirements, products that may be incorporated into the Work include, but are not limited to, the following:
 - 1) ClarkDietrich Metal Framing, “Slp-Trk” Slotted Deflection Track.
 - 2) MBA Building Supplies; FlatSteel Deflection Track, or Slotted Deflecto Track.
 - 3) Steel Network Inc. (The); VertiClip SLD Series or VertiTrack VTD Series.
 - 4) Superior Metal Trim; Superior Flex Track System (SFT).
 - 5) Telling Industries; Vertical Slip Track, or Vertical Slip Track II.
 4. Firestop Tracks: Top runner manufactured to allow the partition heads to expand and contract with the movement of the structure while maintaining the continuity of the fire-resistance-rated assembly indicated; in a thickness not less than indicated for the studs and in a width to accommodate the depth of the studs. Coordinate the track design with Division 07 Section “Firestopping”.
 - a. Available Products: Subject to compliance with the requirements, products that may be incorporated into the Work include, but are not limited to, the following:
 - 1) Fire Trak Corp.; Fire Trak System; may be attached to the studs with “Fire Trak Posi Klip”.
 - 2) Grace Construction Products; Flame Safe FlowTrak System.
 - 3) Metal-Lite, Inc.; The System.
6. Fixture Attachment Backing: Lengths and widths as indicated or otherwise as required.
1. Wood: Subject to compliance with the requirements, provide Clark Dietrich Metal Framing: “Danback” Fire Treated Wood Backing Plate, D16F or D24F, per the spacing of the framing.

2. Steel Anchor Plates for Grab Bars: For securing grab bars at gypsum board partitions. Cold rolled steel, at least 1/8" x 4".
3. Flat Strap and Backing Plate: Steel sheet for blocking and bracing in the length and width indicated. (At fixtures other than grab bars.)
 - a. Minimum Base-Metal Thickness: 0.0360 inch, 20 gauge.

Suggested Suspension System Components

1. Tie Wire: ASTM A 641, Class 1 zinc coating, soft temper, 0.062-inch-diameter wire, or double strand of 0.048-inch-diameter wire.
2. Wire Hangers: ASTM A 641, Class 1 zinc coating, soft temper, 0.16-inch diameter.
3. Carrying Channels: Cold-formed, commercial-steel sheet with an uncoated metal thickness of 0.053 inch and minimum 1/2-inch-wide flanges.
4. Furring Channels (Furring Members):
 1. Cold-Rolled Channels: 0.0538-inch, (17 gauge) uncoated steel thickness, with minimum 1/2-inch-wide flanges, 3/4 inch deep.
 2. Steel Studs: Per "Steel Studs and Runners" under "Steel Framing for Framed Assemblies" below.
 3. Hat-Shaped, Rigid Furring Channels: ASTM C 645-08, 7/8 inch deep.
 - a. Minimum Base Metal Thickness: 0.018-inch, 26 gauge.
 4. Resilient Furring Channels: 1/2-inch-deep members designed to reduce sound transmission.
 - a. Acceptable products include ClarkDietrich Metal Framing Resilient Channel, RCSD (25 gauge).
 5. Steel Studs and Runners: ASTM C 645-08. Use either steel studs and runners or dimpled steel studs and runners.
 - a. Minimum Base-Metal Thickness: As indicated on the Drawings, otherwise:
 - 1) Steel Studs and Runners (non-Dimpled): Minimum Base Metal Thickness: At least 0.025 inch, 25 gauge.
 - 2) Dimpled Steel Studs and Runners: Members that can show certified third party testing in accordance with ICC - ES - AC86 that meets ASTM C645-08 Section 9.2.
 - a) Minimum Base Metal Thickness: 0.015 inch, 28 gauge, 25 gauge-equivalent.
 - b) Acceptable products include ClarkDietrich "UltraSteel" or ProStud" and "ProTrack" Framing, (Install studs in rated partitions per UL V450 or UL V438 or UL U419.)

5. Grid Suspension System for Ceilings: ASTM C 645, direct-hung system composed of main beams and cross-furring members that interlock.
 1. Products: Subject to compliance with the requirements, provide one of the following:
 - a. Armstrong World Industries, Inc.; Drywall Grid Systems.
 - b. Chicago Metallic Corporation; Drywall Furring System, 640-C or 660-C.
 - c. USG Corporation; Drywall Suspension System.

2. AUXILIARY MATERIALS

1. General: Provide auxiliary materials that comply with the referenced installation standards.
2. Fasteners for Metal Framing: Of the type, material, size, corrosion resistance, holding power, and other properties required to fasten the steel members to the substrates.
 1. ASTM C646 self-drilling screws, at least 3/8-inch longer than the materials being fastened, Type S-12 for 0.040 inch, 20 gauge and thicker, Type S for thinner members.

09 24 00 Portland Cement Plastering

Design Standards

1. General:

This section includes the guidelines for the design, materials selection, and application of Portland Cement Plaster/stucco.
2. Comply with Portland Cement Association, Portland Cement Plaster Stucco Manual and ASTM C-926.
3. Portland cement plaster, when used for exterior applications, shall be called stucco.
4. Design Considerations:
 - a. Apply stucco directly to concrete unit masonry or cast-in-place concrete walls without the use of lath accessories.
 - b. Plaster accessories such as corner beads, control joints, plaster stops, etc. are not recommended or permitted and should be avoided where stucco is applied directly to concrete or concrete unit masonry. Accessories tend to crack away from stucco during thermal movement. Intersections of accessory beads are especially prone to leakage.

- c. Where expansion joints occur in the structure, an expansion joint shall be provided through the stucco. A backer rod and sealant are preferable to plaster accessories.
 - d. Where there is a predictable differential movement between substrate materials (such as between concrete unit masonry block and concrete beams and/or columns), or where stress cracks may occur (such as at corners of windows), do not use plaster expansion joints or accessories. If a sealant and backer rod is visually objectionable then apply a section of fiberglass mesh (not metal lath) over the joint or questionable area, stuck into the scratch coat.
 - e. If wall joints are required for aesthetic reasons, or to limit a large area of stucco application, do not use accessories to form the joint. The plasterer shall tool or score the joint, by using temporary wood screeds.
 - f. For stucco applications on suspended ceiling over metal lath, use accessories such as casing beads, corner beads, and control joints over metal lath substrates. The assembly shall be capable of movement, not rigidly tied to structure, walls, or other elements. The use of plastics accessories is preferred.
 - g. Use a maximum of 144 square feet of stucco over metal lath between control joints.
 - h. Avoid elastomeric paints on stucco. Elastomeric paint should only be used over old stucco requiring repairs. The elastomeric paint over new stucco could trap the moisture resulting in blistering.
 - i. Dark colored stucco is more prone to crack than lighter colors, because of heat absorption. Avoid dark colored paint over stucco.
5. Specification Consideration:
- a. Specify recommended bonding agent in these guidelines to be mixed with stucco mix.
 - b. Integrally colored concrete is not permitted, since is hard to patch/retouch.
 - c. Coordinate control joints in structure receiving stucco with structural engineer. These control joints will create a pattern in stucco. These joints need to be filled with sealant and backer rod.
 - d. Avoid the use of waterproofing admixtures in stucco as they can prevent the proper curing process of the plaster.
6. Surface Preparation:
- a. Concrete Surfaces: Mechanically roughen concrete, clean off dust, loose particles and other foreign matter; remove all traces of concrete from release compound in concrete forms.
 - b. Concrete Unit Masonry: Concrete Unit Masonry receiving stucco should have texture face; include this requirement in Concrete Unit Masonry section. Before stucco application, dampen dry surfaces of concrete unit masonry for proper suction.
7. Application: Must comply with Portland Cement Plaster Stucco Manual and ASTM C926, including but not limited to application and thicknesses required.
- a. In general, a two coat application is required over masonry and concrete with a thickness of 5/8 inch.

- b. A three coat application is required over metal lath, with a thickness of 7/8 inch.
- c. In general, use smooth sand finish for ceilings and supports and textured finish for walls.
- d. Request run drip grooves in stucco at exterior doorway heads and exterior window heads.
- e. Request to coordinate work with rough carpentry for proper placement of temporary wood screeds after stucco scratch coat for stucco reveals. After stucco final coat application and removal of wood screeds, to patch stucco reveal to cover nail holes and other defects so those stucco reveal surfaces match adjacent surfaces.
- f. Request that at walls receiving stucco, to embed fiberglass mesh must be embedded over first (scratch) coat at concrete columns and beams extending a minimum of 4 inches over adjacent concrete block walls; also to provide strips (4 inch x 8 inch minimum) of fiberglass mesh over first coat at all corners of openings at masonry and concrete walls receiving stucco.

Product Standards

- 1. Stucco Materials:
 - a. Stucco mix and materials must comply with Portland Cement Plaster Stucco Manual and ASTM C926. In addition the following products should be added to the mix to help prevent cracking and for good bonding.
 - (1) Bonding Compound must be acrylic latex emulsion, water resistant type.
 - (2) Manufacturers and Types:
 - (a) Thoro System Products – Acryl 60.
 - (b) Larsen Products Corp. – Acrylic Admixture 101
 - (c) Lambert, Acrybond Acrylic Admixture
 - b. Fibers for Base Coat: Alkali-resistant, glass or polypropylene fibers, ½ inch long, free of contaminants, manufactured for use in Portland cement plaster.
- 2. Fiberglass Mesh to embed on scratch coat of stucco: Nominal 4.8 oz./sq. yd., symmetrical interlaced open-weave glass fiber fabric made with minimum 25 percent by weight alkaline resistant coating. Acceptable Manufacturer: Sto Mesh by Sto Finish System or other acceptable manufacturer.
- 3. Metal lath must be galvanized. In general, the use of expanded metal lath on suspended ceilings is the standard.
- 4. Exterior accessories must be fabricated from zinc or plastic fabricated from high-impact PVC. Exterior accessories include but are not limited to: Casing beads, control joints, expansion joints, corner beads.

Performance Standards

1. The Design Professional shall request from the Contractor:
 - a. Product Data.
 - b. Shop Drawings showing locations and installation of control and expansion joints including plans, elevations, sections, details of components, and attachments to other work.
 - c. Samples of each accessory required.
 - d. Structural calculations for exterior ceilings and soffits demonstrating compliance with wind loads.
 - e. Applicator qualifications.
 - f. Mock-ups as follows:
 - (1) For Reveals/Scoring work:
 - (a) Prior to installing stucco work, construct panels for application of reveals/scoring, required to demonstrate aesthetic effects as well as qualities of materials and execution. Build mockups to comply with the following requirements, using materials indicated for final unit of Work.
 1. Locate mockups on-site in the location as directed by the Design Professional. Note, that mock-ups can be part of the actual construction project not needing a separate “stand alone” scope if allowed by the UM Project Manager.
 2. Erect mockups 100-sq. ft. minimum by full thickness in presence of Design Professional using materials, including temporary wood screeds.
 3. Demonstrate the proposed range of aesthetic effects and workmanship.
 4. Design Professional and the UMBS Committee must review and accept mockups before start of Work.
 5. Retain and maintain mockups during construction in an undisturbed condition as a standard for judging the completed stucco Work.
 - (2) For Stucco Work:
 - (a) Prior to installing stucco work, construct panels for each stucco texture as required to verify the selections made under sample submittals and to demonstrate aesthetic effects as well as qualities of materials and execution. Build mockups to comply with the following requirements, using materials indicated for final unit of Work.
 1. Locate mockups on-site in the location as directed by the Design Professional.
 2. Erect mockups 100 sq. ft. minimum by full thickness.
 3. Design Professional and the UMBS Committee must review and accept mockups before start of stucco Work.
 4. Retain and maintain mockups during construction in an undisturbed condition as a standard for judging the completed stucco Work.

5. When directed, remove mockups from Project site.
 - (3) Mock-ups: Request mockup for any stucco work.
2. Portland Cement Plaster/Stucco Mixes: Comply with ASTM C 926 and PCA Portland Cement Plaster/Stucco Manual. Obtain UMBS Committee approval for factory prepared finish coat mixes.
 3. Requirements for surfaces receiving stucco
 - a. Planes of solid substrates receiving stucco should not vary more than ¼ inch in 10 ft.
 - b. Mortar joints of concrete unit masonry should be struck flush.
 - c. Surfaces must be roughened to develop a sufficient bond with the plaster.
 - d. Portland cement plaster/stucco will crack if assemblies are subject to differential structural movements. Detail isolation requirements on the drawings. Locate control joints at natural lines of weakness. Comply with ASTM C926 and PCA Portland Cement Plaster/Stucco Manual recommendations.

09 26 13 Gypsum Veneer Plastering

The use of gypsum veneer plaster, applied on gypsum base panels, unit masonry, or monolithic concrete is permitted only with the UMBS Committee approval.

09 27 13 Glass-Fiber-Reinforced Plaster Fabrications

The use of factory-molded glass-fiber-reinforced plaster units may be permitted for interior use only with the UMBS Committee approval.

09 29 00 Gypsum Board

Design Standards

The intent of these standards is to provide general guidelines to the design professional on the design, quality of installation and QAQC of the finished materials, assembly and material for both interior and exterior applications on a building. These standards shall not supersede code and regulations nor relieve the design professional from their professional responsibility.

5. Selection of gypsum wall assemblies, applications and products should be preceded by a careful analysis of applicable building codes, building regulations and authorities having jurisdiction. Select approved materials as applicable for insulation, abuse, finishes, impact and fire-resistance designs should be based on applicable industry construction standards and application recommendations from manufacturers.

6. The Design Professional should select materials that are durable and able to cope with South Florida weather conditions. Finishes shall allow for cleaning of graffiti or stains with relative ease for maintenance staff. The design and selection of finishes shall be based on the following:
 7. Vandal resistance.
 8. Cost effectiveness.
 9. Durability
 10. Resistance to crack and peeling
 11. Resistance to fading or discoloration from exposure, abrasion, cleaning and sunlight, weather tightness under normal and hurricane conditions
 12. Absence of excessively rough or sharp textures or features.
7. Studies have shown that materials are a major contributor to “sick building syndrome”. In consequence, building materials used for UMBS shall not contain asbestos, lead, formaldehyde, mercury, volatile organic chemicals (VOCS), or any other determined to be harmful products. Only non-toxic adhesives are to be used.

Product Standards

1. Compliance with tested fire-resistance designs requires strict adherence to the materials and design details as indicated in UL’s Fire Resistance Directory.
3. Environmental Limitations: Comply with ASTM C 840 requirements or gypsum board manufacturer’s written recommendations, whichever are more stringent. Design Professional shall specify that HVAC systems shall be operational and shall maintain at a minimum 76 +/- 2 degrees F. and a constant 55 +/- 2 percent relative humidity for a period of 3 days (72 hours) prior to the commencement of finishes.
4. The design professional should specify a 5/8” impact/abuse resistant, mold / moisture resistant gypsum drywall board in all student occupied spaces. These areas include the administration areas, student services areas, student dormitories, staff facilities and media centers.
5. The design professional could specify exterior concrete board system reinforced with vinyl-coated, woven glass fiber mesh only at fascia’s, soffits and other decorative elements not part of the structural building envelope.
6. Do not install paper-faced gypsum panels until installation areas are enclosed and conditioned.
7. Do not install panels that are wet, those that are moisture damaged, and those that are mold damaged.
 1. Indications that panels are wet or moisture damaged include, but are not limited to, discoloration, sagging, or irregular shape.
 2. Indications that panels are mold damaged include, but are not limited to, fuzzy or splotchy surface contamination and discoloration.

8. The following ASTM standards shall apply to the selected gypsum drywall selected by the design professional.
 1. Gypsum Wallboard: ASTM C 1396/C 1396M
 2. Gypsum Board, Type X: ASTM C 1396/C 1396M
 3. Flexible Gypsum Board: ASTM C 1396/C 1396M. Manufactured to bend to fit radii and to be more flexible than standard regular-type gypsum board of same thickness.
 4. Gypsum Ceiling Board: ASTM C 1396/C 1396M.
 5. Foil-Backed Gypsum Board: ASTM C 1396/C 1396M
 6. Abuse-Resistant Gypsum Board: ASTM C 1629/C 1629M
 7. Moisture- and Mold-Resistant Gypsum Board: ASTM C 1396/C 1396M. With moisture- and mold-resistant core and paper surfaces.
 8. Gypsum Board, Type C: ASTM C 1396/C 1396M. Manufactured to have increased fire-resistive capability.
 9. Glass-Mat Interior Gypsum Board: ASTM C 1658/C 1658M. With fiberglass mat laminated to both sides. Specifically designed for interior use.
 10. Acoustically Enhanced Gypsum Board: ASTM C 1396/C 1396M. Multilayer products constructed of two layers of gypsum boards sandwiching a viscoelastic sound-absorbing polymer core.
 11. Skim-Coated Gypsum Board: ASTM C 1396/C 1396M. Manufactured with a factory-applied skim coat.
 12. Exterior Gypsum Soffit Board: ASTM C 1396/C 1396M, with manufacturer's standard edges.
 13. Glass-Mat Gypsum Sheathing Board: ASTM C 1177/C 1177M, with fiberglass mat laminated to both sides and with manufacturer's standard edges.
 14. Glass-Mat, Water-Resistant Backing Board: ASTM C 1178/C 1178M, with manufacturer's standard edges.
 15. Cementitious Backer Units: ANSI A118.9 and ASTM C 1288 or 1325, with manufacturer's standard edges.
 16. Water-Resistant Gypsum Backing Board: ASTM C 1396/C 1396M, with manufacturer's standard edges.

Performance Standards

1. Fire-Resistance-Rated Assemblies: For fire-resistance-rated assemblies, provide materials and construction identical to those tested in assembly indicated according to ASTM E 119 by an independent testing agency.
2. STC-Rated Assemblies: For STC-rated assemblies, provide materials and construction identical to those tested in assembly indicated according to ASTM E 90 and classified according to ASTM E 413 by an independent testing agency.
3. Low-Emitting Materials: For ceiling and wall assemblies, provide materials and construction identical to those tested in assembly and complying with the testing and product requirements of the California Department of Health Services' "Standard

Practice for the Testing of Volatile Organic Emissions from Various Sources Using Small-Scale Environmental Chambers."

4. Specify products only after carefully considering each for its applications, properties, tested performance, serviceability, and appearance, when exposed to view, and cost.
3. Selection and use of gypsum board finish levels shall follow accepted industry standards: All finish panels shall be finished to levels indicated and defined below and according to ASTM C 840 requirements.
 1. Level 1 Finish: Typically where the recommendation for areas that are generally concealed from view or in areas that are not open to the public traffic. The joint tape need not be covered with joint compound to fulfill the requirement of level 1, the surface is left free of excess joint compound. Ridges and tool marks are acceptable for a level 1 finish. Typically it can be used from plenum areas above ceilings, concealed spaces or in service corridors.
 2. Level 2 Finish: Typically where the recommendation for areas where final surface appearance is not of concern. Level 2 may be specified where moisture resistant gypsum board is used as a substrate with all joints and interior angles shall have tape over all joints and interior angles. Joint compound is applied over all fasteners heads and beads. The surface is left free of excess joint compound. Ridges and tools marks are acceptable for a level 2 finish. Additionally joint compound is applied over all body of the tape at the time of tape embedment and shall be considered a separate coat of joint compound and shall satisfy the conditions of this level.
 3. Level 3 Finish: Typically where the recommendation for areas where final surface appearance shall be decorated with a medium or heavy hand and spray applied textures or where heavy-grade wall coverings will become the final decoration. Level 3 shall become the recommended level application. All joints and interior angles shall have tape embedded in joint compound over all joints and interior angles. One additional coat of joint compound shall be applied to all joints and interior angles. Fastener heads and accessories shall be covered with two separate coats of joint compound. All joint compound shall be smooth and free of tool marks and ridges. Prior to any application of final décor. It is recommended that the surface be coated with a drywall primer prior to the application of the final finish. Level 3 is not recommended for smooth painted surfaces, light textures, or light- to medium-weight wall coverings become the final decoration.
 4. Level 4 Finish: Typically for areas where final surface appearance shall be for flat paint, light texture or lightweight wall covering, a level 4 finish is recommended. All joints and interior angles shall have tape embedded in joint compound and shall immediately wiped with a joint knife leaving a thin coat of joint compound over all joints and interior angles. Two separate coats of joint compound shall be applied over all flat joints and one separate coat of joint compound shall be applied over interior angles. Fastener heads, and accessories shall be covered with three separate coats of joint compound. All joint compounds shall be smooth and free of tool marks and ridges. It is recommended that the prepared surface be coated with a wall primer prior to the application of final finishes. In sever lighting conditions, flat paints applied over light texture tend to reduce joint

telegraphing or photographing. Paints with sheen levels other than flat as well as enamel paints are not recommended over this level of finish. Special attention should be paid to long corridors, large areas of wall, and large / multiple windows when level 4 is specified, because these areas of concern in achieving acceptable wall finishes, and may need to be specified appropriately.

5. Level 5 Finish: Typically for areas where final surface appearance shall be where severe lighting conditions exist and areas that are scheduled to receive a gloss, semi-gloss, eggshell or satin enamel or non-textured flat paint. Level 5 requires all operations in the previously indicated level 4, additionally, a thin “skim coat” of joint compound, or material manufactured especially for this purpose, is applied to the entire surface. A “skim coat of joint compound is intended to conceal small imperfections in the joints and on the surface of the actual gypsum board to help conceal joints and create the appearance of flatness. A skim coat will also smooth texture of the paper, minimize the differences in surface porosity and create a more uniform surface to which the final decoration can be applied. A level 5 finish is required to achieve the highest degree of quality by providing a uniform surface and minimize the possibility of joint photographing and/ or fasteners showing through the final finish décor. Areas where walls or ceilings are adjacent to large glass areas, long hallways, or atriums with large surface areas flooded with artificial or natural light are considered critical lighting areas. Level 5 finishes provide the acceptable level of finish standard to address these concerns.
6. The design professional shall consider that each level finish as described in a recommendation is intended to stand alone. The levels described are not cumulative.
7. Application in some case but not all that use a surface coated with a high quality, high solid “drywall primer” prior to the application of final paint minimizes in some instances but not all décor or decorating problems.

Delivery, Storage and Handling

4. Store materials inside under cover and keep them dry and protected against weather, condensation, direct sunlight, construction traffic, and other potential causes of damage. Stack panels flat and supported on risers on a flat platform to prevent sagging.

Installation Guidelines

1. When Single-Layer Application:
 1. On ceilings, apply the gypsum panels before the wall/partition board application to the greatest extent possible, and at right angles to the framing, unless otherwise indicated.

2. On partitions/walls, apply the gypsum panels vertically (parallel to the framing), unless otherwise indicated, or required by the fire-resistance-rated assembly; minimize the quantity of end joints.
 - a. Stagger abutting end joints not less than one framing member in alternate courses of the panels.
 - b. At high walls, install the panels horizontally, unless otherwise indicated, or required by the fire-resistance-rated assembly.
 3. Fastening Methods: Apply the gypsum panels to the supports with steel drill screws.
2. When Multilayer Application:
1. On ceilings, apply the gypsum board indicated for base layers before applying the base layers on the walls/partitions; apply the face layers in same sequence. Apply the base layers at right angles to the framing members and offset the face-layer joints one framing member, 16 inches minimum, from the parallel base-layer joints, unless otherwise indicated or required by the fire-resistance-rated assembly.
 2. On partitions/walls, apply gypsum board indicated for the base layers and face layers vertically (parallel to the framing) with the joints of the base layers located over a stud or furring member and the face-layer joints offset at least one stud or furring member with the base-layer joints, unless otherwise indicated or required by the fire-resistance-rated assembly. Stagger the joints on opposite sides of the partitions.
 3. Fastening Methods: Where required for fire-resistance-rated assemblies fasten the base layers and face layers separately to the supports with screws. Otherwise, fasten the base layers with screws; fasten the face layers with adhesive and supplementary fasteners.

Trim Accessories

1. General: For trim with back flanges intended for fasteners, attach to the framing with the same fasteners used for the panels. Otherwise, attach the trim according to the manufacturer's written instructions. Metal corner beads are not allowed, design professional to use plastic accessories.
2. Control Joints: Install control joints according to ASTM C 840 and in specific locations determined by the Architect for visual effect, or at the locations indicated on the Drawings.
3. Interior Trim: Install in the following locations:
 1. Cornerbead: Use at outside corners, unless otherwise indicated.

2. LC-Bead: Use at exposed panel edges.
 3. L-Bead: Use where indicated.
3. FINISHING GYPSUM BOARD
1. General: Treat gypsum board joints, interior angles, edge trim, control joints, penetrations, fastener heads, surface defects, and elsewhere as required to prepare the gypsum board surfaces for decoration. Promptly remove residual joint compound from adjacent surfaces.
 2. Pre-fill open joints, rounded or beveled edges, and damaged surface areas.
 3. Apply joint tape over the gypsum board joints, except those with trim having flanges not intended for tape.
4. PROTECTION
1. Protect the installed products from damage from the weather, condensation, direct sunlight, construction, and other causes during remainder of the construction period.
 2. Remove and replace panels that are wet, moisture damaged, and mold damaged.
 1. Indications that panels are wet or moisture damaged include, but are not limited to, discoloration, sagging, or irregular shape.
 2. Indications that panels are mold-damaged include, but are not limited to, fuzzy or splotchy surface contamination and discoloration.

09 30 00 Tiling

Design Standards

1. General:
 - a. Tile work shall be designed and specified in accordance with the current edition of the "Handbook for Ceramic Tile Installation" by the Tile Council of North America" (TCNA). Indicate extent and any patterns of tile work on the drawings. Provide details for setting beds and joints. Provide details for setting beds, expansion and control joints, waterproofing, and drain seals.
 - b. Products shall comply with ANSI Standard A137.1, "American Standard Specifications for Ceramic Tile".
 - c. Do not mix manufacturers. It is preferred that all tile for a project be from one manufacturer.
 - d. Consider products with recycled content.
 - e. When patching tile in existing areas, develop a pattern rather than merely replacing required tile.

- f. Trim units shall match characteristics of field tile. Bases shall be straight type; edges shall be bullnose.
- g. Setting materials, grouts and sealants shall be appropriate for the installation method.
- h. Provide cement board backing at all wet locations.
- i. Coordinate and detail movement joints with building details. Follow the TCNA EJ171 Recommendations.
- j. Where not supplied on a backing material, tile shall be placed with metal grid template. Do not use spacer buttons on tile edges. Width of tile joints shall be as recommended by the manufacturer.
- k. Joint between floor and wall tile shall be sealed with urethane sealant, not grouted.
- l. Tile at Floors:
 - (1) Porcelain tile or quarry tile with matte finish is required. Glazed or polished tiles are prohibited.
 - (2) Restroom floors: 2-inch x 2-inch x 1/4-inch nominal thickness ceramic mosaic floor tile. Use coved ceramic mosaic tile base and marble thresholds color white, MIA Group "A", complying with ASTM C 503. Slope finished floor to drain over the entire room.
 - (3) Quarry Tile: 8-inch by 8-inch or 6-inch by 6-inch by 1/2-inch nominal thickness, unglazed, with non-abrasive wearing surface and matching flush cove base. 100 percent solids, two-part, epoxy mortar and grout at food prep areas.
 - (4) Tile Colors: Medium tone, neutral colors are preferred.
- m. Tile at Walls:
 - (1) Restrooms: 5/16"-inch minimum thickness glazed ceramic wall tile. Provide ceramic tile finish at all walls, not only wet walls, to at least $\pm 6'-0"$ above finish floor level, in whole tile increments. Leave approximately 12" (minimum) of painted gypsum board from the ceiling.
 - (2) Apply at wall areas adjacent to drinking fountains or areas where water might splash and cause staining or deterioration of wall surfaces.
 - (3) Tile colors: neutral colors are preferred.
- n. Grout
 - (1) Use epoxy type grout meeting ANSI 118.3.
 - (2) Grout shall match tile color.
- o. Adhesive:
 - (1) Tile adhesive shall meet LEED Standards 4.1/4.2EQ (Indoor Air Quality), 4.2MR (Recycled Materials) and 5.1/5.2MR (Regional Materials).

Performance Standards:

1. Comply with ANSI Ceramic Tile Standards. Installation must comply with Tile Council of North America standards (TCNA).
2. Floor tile static coefficient of friction comply with ASTM C 1028 level surfaces and stair treads 0.6 minimum(dry surfaces), ramp surfaces 0.8 minimum (dry surfaces).

3. Latex-Portland cement mortar (thin-set): Compliance with ANSI A108.5 and ANSI A118.4 required. Mortar coverage: 95% minimum. Latex Portland cement for gypsum board and cement board.
4. Medium-bed, latex Portland cement mortar: Use for for tiles 8-inch x 8-inch or larger. Compliance with ANSI A118.4 required.
5. Portland cement mortar (thick-set): For application over waterproofing membrane at shower stalls and where required by job conditions and selected tiles.
6. Waterproofing membrane at shower stalls and where indicated: Use waterproofing membrane approved by Florida Building Code.
7. Full waterproofing membrane under all bathroom and janitor closet floors.
8. Polymer type grout acrylic resin or styrene-butadiene rubber in liquid-latex form for addition to prepackaged dry-grout mix.

09 30 33 Stone Tiling

1. Modular, cut stone units may be permitted only with UMBS Committee approval.

09 51 23 Acoustical Ceiling Panels

Design Standards

1. General:
 - a. This section includes the guidelines for the design and materials selection of suspended acoustical panel ceilings.
 - b. Select acoustical ceiling systems based on durability, recycled content, lack of Urea-Formaldehyde content, and required acoustical value. Ceilings shall provide the required NRC/CAC STC acoustical ratings for the specific areas as required by UM and acoustical consultant if available.
 - c. Provide acoustical ceilings panels at all interior spaces, except those subject to moisture, wet areas, or where exposed plenum, gypsum or other ceiling products are required by program; or as otherwise provided by programmatic requirements.
 - d. Request from the Contractor manufacturer's literature including material specifications for ceiling type and suspension system components, printed installation directions, samples, and maintenance recommendations for each type of panel required.
 - e. Colors, other than white, shall be subject to approval by the UMBS Committee.
 - f. In renovation or remodeling of existing facilities, the restoration of existing ceilings may be an option in lieu of total replacement. Evaluate the cost of cleaning the existing lay-in ceiling and grid system versus installing a new ceiling

- system and obtain approval by the UMBS Committee. Cleaning products shall be non-toxic, non-flammable, odorless and in conformance with safety practices; request mockup samples before proceeding with refurbishing work. Consult with the ceiling system manufacturer; verify that refurbishment does not affect warranties.
- g. Specify the system type, size, finish, sound absorption (NRC), STC rating, light reflectance, and fire rating as applicable to each room and condition.
 - h. Reflected ceiling drawings shall coordinate all ceiling elements and penetrations including but not limited to lighting, sensors, sprinklers heads, HVAC accessories, alarms, lighting, etc.
 - i. Design ceilings so that grids are centered continuous to other adjacent areas where possible.
 - j. Center the grid or panel in the space to avoid the use of panels less than 6 inches in width.
 - k. If regular panels are cut in the field, match the factory reveal.

Product Standards

1. Approved Products:
 - a. Acoustical Panel for General Use: Armstrong Ultima NRC70 impact resistant or USG "Eclipse" Panels #76775, 2 ft x 2 ft x $\frac{3}{4}$ inch thick with angled slanted edges.
 - b. Acoustical Panels for open office use: Armstrong Optima NRC 1.0, 2'x 2" x $\frac{3}{4}$ inch regular panel (white); field cuts; must match factory bevel and fin.
 - c. Acoustical Panel for Kitchen and Food Preparation Areas: Armstrong, Clean Room Mylar Face #1715 Smooth face panels, 2 ft x 2 ft x $\frac{3}{4}$ inch thick with square edges or USG Sheetrock ClimaPlus Lay-in #3260.
 - d. Acoustical Panel for Gymnasium and Physical Education Areas: Use Armstrong Armatuff # 861 panels or USG Rock Face ClimaPlus #56335, 2 ft x 2ft x $\frac{3}{4}$ inch thick, with square edges; add retention clips.
 - e. Acoustical Panel for Laboratories: Use Armstrong Ceramaguard Medium Texture #607 panels or USG Radar Ceramic ClimaPlus #56644, 2 ft x 2 ft x $\frac{5}{8}$ inch thick with square edges; or similar by USG.
 - f. Avoid using Acoustical Panel Ceilings in Toilet Rooms and Shower Rooms.
 - g. Acoustical Panel Ceiling other than above listed shall be submitted to the UMBS Committee for approval.
 - h. Suspension system: 15/16" grid (white) fabricated from hot dipped galvanized steel with white baked enamel finished Aluminum Cap, complying with ASTM C635. Acceptable manufacturers: Prelude XL High Recycled Content by Armstrong; or USG Donn ZXLA / DXACE flat finish. Other ceiling suspension systems shall be submitted to the UMBS Committee for approval.
 - i. Back of House (verify with the UMBS Committee for applicable areas): Armstrong School Zone fine fissured; NRC .70, impact resistant.

2. Product Characteristics:
 - a. Surface burning characteristics: Class "A" - flame spread 25 or under; smoke developed 50 or under; UL labeled.
 - b. Antimicrobial solution: Bio Block coating on both faces of panel to inhibit growth of mold and mildew.
 - c. Sag resistance: HumiGuard Plus by Armstrong or equivalent.
 - d. Hangers: Appropriate to structure and acceptable to ceiling manufacturer.
 - e. String Isolations:

Performance Standards

1. Submit certified laboratory test reports and other data as required for each acoustical ceiling panel and suspension system component required to show compliance with specifications.
2. Submit for review 12 inch square samples of each type ceiling acoustical panel required and 6 inch long pieces of each suspension system component required. Panel samples shall indicate full range of color and texture that will be the standard of quality in the finished installation.
3. Provide complete and coordinated reflected ceiling plans, showing all ceiling mounted devices, including but not limited to sprinkler heads, diffusers, electrical detectors, lighting, etc.
4. The installer shall have a minimum of five years experience in projects of the same type and size of installation. Installers that are certified by the manufacturer are preferable.
5. Require that installation of acoustical panel ceilings be performed only when temperature and humidity conditions approximate the interior conditions that will exist when the building is occupied.
6. Installation of grid suspension system must be in strict accordance with ASTM C636 and manufacturer's published installation drawings, properly leveled in place to a tolerance of 1/8 inch in 12 feet. The Design Professional shall specify the type of hangers and other installation requirements.
7. General Installation Requirements:
 - a. Increase the size and strength of suspension system to support light fixtures, acoustical units and related items without deflecting more than 1/360 of the span when tested as a simple beam, ends free, center reading.
 - b. Provide metal edge trim at openings, and perimeter. Indicate on drawings and specifications type of edge trim
 - c. Request coordination with mechanical and electrical work being performed in areas receiving piping, ducts, electrical and other work that is to be concealed by the ceiling shall be completed, tested and inspected and the proper

- ceiling height and level established before ceiling system components are installed.
- d. Coordinate labeling requirements for identification of all concealed MEP items that require access for operational or maintenance purposes. (See MEP divisions).
8. Warranty on Acoustical Panel Ceiling: Manufacturer's standard 30- year limited warranty including:
- a. Dimensional stability.
 - b. Resistance to impact, humidity, mold/mildew, bacterial growth, corrosion and chemical exposure.
 - c. Product will be free from warping and sagging resulting from defects in materials and factory workmanship.

09 54 23 Linear Metal Ceilings

The use of strip or decorative metal ceiling systems may be permitted only with the UMBS Committee approval.

09 54 36 Suspended Decorative Grids

The use of plenum mask ceiling systems may be permitted only with the UMBS Committee approval.

09 54 43 Stretched-Fabric Ceiling Systems

The use of site-assembled and upholstered fabric ceiling systems for may be permitted only with the UMBS Committee approval.

09 54 46 Fabric-Wrapped Ceiling Panels

The use of shop-fabricated or fabric-wrapped panels, either applied to or suspended from the ceiling may be permitted only with the UMBS Committee approval.

09 63 40 Stone Flooring

The use of exterior and interior stone flooring (not including stone tile) may be permitted only with the UMBS Committee approval.

09 64 00 Wood Flooring

The use of wood flooring, solid field and factory finished, may be permitted only with the UMBS Committee approval.

09 64 66 Wood Athletic Flooring

The use of wood athletic flooring (Maple flooring with shock-absorbing subfloor assemblies) may be permitted only with the UMBS Committee approval.

09 65 00 Resilient Flooring, Base and Accessories**Design Standards**

1. General:
This section includes the criteria for resilient flooring, base and accessories:
 - a. Vinyl composition tile, marmoleum, bio-based composition tile.
 - b. Vinyl flooring.
 - c. Rubber flooring.
 - d. Linoleum flooring.
 - e. Static-control flooring.
 - f. Rubber base.
 - g. Edge strips.
2. The following criteria shall be considered when selecting the appropriate type of resilient flooring:
 - a. Room type.
 - b. Style.
 - c. Budget.
 - d. Amount and frequency of foot traffic and rolling carts (psi requirements).
 - e. Noise absorption requirements.
 - f. Type of stains expected (food, oil, chemicals).
 - g. Level of maintenance required.
3. Flooring should be slip resistant and meet the following test results:
 - a. Slip Resistance: Static coefficient of friction (James Test): ASTM D2047, plus/minus 0.5.
 - b. Fire-Test-Response Characteristics: testing according to ASTM E 648 or NFPA 253.
 - c. Critical Radiant Flux Classification: Class I, not less than 0.45 W/sq. cm.
 - d. Depending on program requirements, resilient flooring may be acceptable for use at circulation areas, elevators, break rooms, support areas, dorm rooms, classrooms with less than 50 occupants and laboratories.
 - e. Resilient flooring materials not permitted:
 - (1) Cork and laminate.
 - (2) Sheet or tile vinyl products except for UMBS Committee approved specialized areas.
 - f. When possible, specify PVC-free and chlorine free resilient flooring products.
 - g. Heat welded seams and coved base may be required for specialized areas.

- h. Forbo Marmoleum Composition Tile (MCT) or Armstrong Migrations Bio-Based tile is preferred to VCT, however these materials can stain and will require maintenance.
 - i. Flooring should meet LEED Standards such as 4.3EQ (Low-Emitting Materials), 4MR (Recycled Content), 5MR (Regional Materials) and 6MR (Rapidly Renewable Resources), as appropriate for the Work.
 - j. Resilient Base
 - (1) Meet ASTM F 1861 Type TS rubber, continuous roll.
 - (2) Use cove base 1/8-inch thick by 4-inch high (minimum). Straight base at carpet requires approval by the UMBS Committee.
 - (3) Medium tone neutral colors are preferred.
 - k. Resilient Stair Treads and Risers
 - (1) Rubber stair tread with integrated risers are preferred.
 - (2) Specify matching rubber stringers and landings by the same manufacturer as the stair tread.
4. The Contract documents shall include coordinated finish schedules and specifications.
5. The Design Professional shall ensure that substitutions do not modify the intended aesthetic effects previously approved by the UMBS Committee.
- a. Preferred Manufacturers:
 - (1) Armstrong
 - (2) Mannington
 - (3) Centiva
 - (4) Amtico
 - b. Verify colors and patterns with University Architect.
6. Where demountable partitions and other items are indicated for installation on top of resilient flooring, install flooring prior to the installation of the demountable partitions.

Products Standards

1. Approved Manufacturers: Provide products from one of the following manufacturers:
- a. Vinyl Composition Tile: In general, select design from Armstrong World Industries, Inc., Imperial Texture or Stonetex (10 to 20% recycled content.) Design and color to be approved by UM. Other acceptable manufacturer: Azrock Commercial; Congoleum; Mannington.
 - b. Non-Vinyl Composition Tile: Armstrong Migrations Bio-based Resilient Flooring Tile (BBT), or Forbo Marmoleum Composition Tile (MCT).
 - c. Linoleum Flooring: Johnsonite Harmonium xf, Armstrong Linoleum flooring, Forbo Marmoleum and Artoleum,
 - d. Rubber Flooring: Mondo Commercial Flooring. Nora Systems, Inc., Ecosurfaces Commercial Flooring, Johnsonite. UM approval is required for any design and color selected.
 - e. Rubber Base: Armstrong; Johnsonite; Burke/Mercer; Roppe. Use premolded exterior and interior corner or field formed exterior and interior corners. Use cove base. UMBS Committee approval is required for color.

- f. Rubber Stair Tread/Risers; Johnsonite.
 - g. Edge Strips:
 - (1) Resilient Edge Strips: fabricated from vinyl. Select from the following manufacturers: Burke/Mercer; Johnsonite; Roppe. Indicate configuration on drawings.
 - (2) Metal Edge Strips: fabricated from aluminum or stainless steel. Indicate configuration on drawings.
2. Approved Products/Dimensions:
- a. Vinyl Composition Tile: 12 inch x 12 inch x 1/8 inch thick or 18" x 18" x 1/8".
Non-Vinyl Composition Tile: 12 inch x 12 inch x 1/8 inch thick or 13" x 13" x 1/8".
 - b. Sheet Vinyl Flooring: Approximately 0.085 inch thick. Use welding rods at joints.
Linoleum Flooring: Tile or sheets as per project requirements.
 - c. Studded Rubber Flooring:
 - (1) 39 inches x 39 inches x 1/8 inch thick low profile studded.
 - d. Rubber Base:
 - (1) 4 inch high, 1/8 inch thick, top-set.
 - e. Edge Strips: Vinyl or Metal. Configuration: To be selected.
 - f. Weld Rod: Material produced by manufacturer of sheet vinyl flooring for use in heat welded seams.
 - g. Primer: Tile manufacturers published recommended low VOC product for surface conditions of this installation. Non-staining type.
 - h. Flooring and Base Adhesive: Waterproof, VOC content of 50 g/l or less, stabilized type as recommended by flooring manufacturer.
 - i. Floor Polishing Compound: Low VOC product per manufacturer's recommendations to retain or improve flooring coefficient of friction.
 - j. 4" H vinyl base, straight at carpet condition, cove base at all others, performed piece at all corners.
3. Colors: The Design Professional shall select colors from standard manufacturer's charts, unless custom colors are requested and approved by UM. Each color to be from one dye lot the UMBS Committee approval required.

Performance Standards

1. The Design Professional shall require the following submittals:
- a. Product data, including specifications and printed installation instructions.
 - (1) Request data on coefficient of friction and fire test results for resilient flooring.
 - b. VOC Content for adhesives, primer, heat welding.
 - c. Recycled content of flooring and related accessories.
 - d. Other LEED requirements per LEED CHECKLIST
 - e. Samples: Full color range samples of each type of resilient flooring, base and accessory for selection by Design Professional. Sample of welding rods for sheet vinyl.
 - f. Installer qualifications.

- b. Primary terrazzo materials used in the floor surfacing shall be the products of a single manufacturer. Secondary materials including patching and fill material, joint sealant, and repair materials shall be of type and from source recommended by the manufacturer of primary materials.
3. Acceptable installer:
 - a. Must be a contractor member of the NTMA and perform all work in accordance with NTMA standards.
 - b. Installer must be acceptable to materials manufacturer.
 - c. Mock-up: Prior to starting application of flooring, provide full scale portable mock-up to establish acceptable quality, durability, and appearance. Mock-up size must not be less than 4 square feet.
 - (1) Acceptable mock-up to be standard of quality for installed work.
 - (2) Unacceptable installed work is to be removed and replaced or refinished, until acceptable by the UMBS Committee.
4. Acceptable Substrates
 - a. Level tolerance: Concrete subfloor shall be level with a maximum variation from level of 1/4" in 10 feet. Any irregularity of the surface requiring patching and/or leveling shall be done using material approved by the manufacturer.
 - b. Concrete floor shall receive a light steel trowel finish.
 - c. Concrete shall be cured a minimum of 28 days. No curing agents are to be used in areas to receive terrazzo.
 - d. Concrete slab shall have an efficient puncture-resistant, reinforced moisture vapor barrier 10 mils thick minimum placed directly under the concrete slab (for slab on grade). Do not use vapor barrier manufactured with recycled material. Testing must be done to verify that the moisture vapor emission rate of the slab does not exceed that as recommended by the manufacturer at time of installation of the flooring or at any future date. Moisture vapor emission and moisture content testing must conform to the requirements of ASTM F-1869 (Calcium Chloride Test) and ASTM F-2170 (Relative Humidity Probe Test). Should test results show excessive levels of moisture content or vapor emission rate, apply manufacturer's recommended moisture vapor emission control material based upon the highest test reading.
 - e. Saw cutting of control joints must be done between 12 and 24 hours after placement of the structural concrete.
5. Acceptable materials:
 - a. Thickness: 3/8 inch
 - b. Primer: Only as recommended by the manufacturer.
 - c. Epoxy resin binder shall be mixed according to manufacturer's recommendation and tested without aggregate added. All specimens cured for 7 days at 75 degrees plus or minus 2 degrees Fahrenheit and 50% plus or minus 2% R.H. The product shall meet the following requirements:

Property	Test Method	Requirement
Hardness	ASTM D-2240 using Shore D Durometer	60-85
Tensile Strength	ASTM D-412 Specimen made using "C" die	3,000 psi Minimum
Compressive Strength	ASTM D-695 Specimen "B" cylinder	10,000 psi Minimum
Chemical Resistance	ASTM D-1308 seven days at room temperature by immersion method	No deleterious effects: Distilled Water Mineral Oil Isopropanol Ethanol 0.025 Detergent Solution 1% Soap Solution 10% Sodium Hydroxide 10% Hydrochloric Acid 30% Sulfuric Acid

- d. Epoxy Resin shall be mixed according to manufacturer's recommendations and blended with 3 volumes of Georgia White marble blended 60% #1 chip and 40% #0 chip, ground and grouted with epoxy resin according to 3.02 C-2. Finishing to a nominal 1/4" thickness. All specimens cured 7 days at 75 degrees plus or minus 2 degrees Fahrenheit and 50% plus or minus R.H. The finished epoxy terrazzo shall meet the following requirements:

Property	Test Method	Requirement
Flammability	ASTM D-635	Self-extinguishing, extent of burning .025 inches maximum.
Thermal Coefficient of Linear Expansion	ASTM-D-696	25 x 10 ⁻⁶ inches per inch per degree to 140 degrees Fahrenheit
Bond Strength	ACI Committee No. 403/503 Bulletin Title No.59-43 (Pages 1139-1141)	100% concrete failure minimum, with 300 PSI minimum tensile strength.

Note: This test is intended to evaluate the bond to the concrete subfloor and is to be tested at the discretion of the Design Professional. A 100% concrete failure indicates a good bond.

6. Marble Chips or Glass Aggregate:
 - a. Size: To conform to NTMA gradation standards.
 - b. Hardness according to ASTM C-241 Ha-10 minimum.
 - c. 24 hours absorption rate not to exceed 0.75 percent.
 - d. Chips shall contain no deleterious or foreign matter.
 - e. Dust content less than 1% by weight.
7. Strips:
 - a. Stop and divider "L" strips shall be fabricated from zinc.
 - b. Note: select from following the gauge: 18, 16 or 14 B & S gauge or 1/8, 1/4, or 3/8 inch heavy top "L" or "K" type. 2. Construction joint double "L" strips (do not use neoprene joint filler material)
8. Terrazzo Cleaner:
 - a. pH factor shall be between 7 and 10 where applicable.
 - b. Biodegradable and phosphate free.
9. Sealer:
 - a. Terrazzo shall be sealed with an acrylic or urethane terrazzo sealer or other suitable finish system:
 - (1) pH factor shall be between 7 and 10, where applicable.
 - (2) Shall not discolor or amber.
 - (3) Flash Point: ASTM D-56, 80 degrees Fahrenheit minimum, where applicable.
 - (4) Special stain and/or chemical resistant sealers are needed for certain areas such as resistance to iodine or Betadine.
COF obtained with sealer: 1028 level surfaces and stair treads 0.6 minimum (dry surfaces), ramp surfaces 0.8 minimum (dry surfaces).
 - (5) Some finish systems require unsealed terrazzo for proper installation, to function as designed and to achieve the desired aesthetic effect, consult with Manufacturer of the finish system for requirements.
 - (6) Any sealer or finish system not supplied by manufacturer should be properly tested with a mock-up before use. Silicate based densifiers in particular should be carefully tested, as they react only with marble chips and will result in a higher degree of polish of the marble chips versus the epoxy matrix, possibly causing a mottled effect.)

09 67 23 Resinous Flooring

The use of fluid-applied monolithic flooring including decorative epoxy and urethane resins may be permitted only with UMBS Committee approval.

09 68 00 Sheet Carpeting and Carpet Tiles**Design Standards**

1. General:
 - a. This section includes the guidelines for the design, materials selection and installation of broadloom carpeting and carpet tiles.
 - b. Prior to carpet selection, the Design Professional shall request a copy of the latest "Carpet Specifications" developed by the Facilities Management Department. This document contains detailed instructions for purchasing, as well as a list of all approved products and vendors by areas.
 - c. The University of Miami has signed an agreement with Shaw/Patchcraft to purchase carpet directly from the mill at significant cost savings.
 - d. The University has also bid and contracted with Ramon Carpet Service as the approved installer.
 - e. No carpeting should be installed over asbestos tile. If the Design Professional suspects that the tile contain asbestos, he/she must notify the UM Project manager, who will order the required testing. Should be presence of asbestos be confirmed, the tiles must be properly abated prior to carpet installation.
 - f. Carpeting finish shall be restricted to areas designated by the Standard Interior Finishes for Standards Spaces Chart, (Division 09).
 - g. Classrooms – Where carpeting is recommended by the design professional for classroom installations, only carpet tile shall be specified. In deciding to use carpet tile in classrooms, acoustical, comfort and appearance issues should be weighed against maintenance issues (PM to coordinate). In large classrooms, i.e. the auditorium or tiered classrooms, the use of carpet tile is restricted to aisles and entry levels. Do not specify carpet tiles under fixed seating.
 - h. Selection of carpet materials (and enhanced cushion backing systems) should address the traffic characteristics, the likelihood and types of potential staining agents, and the required longevity of the installation.
 - i. Carpet selections should take advantage of sustainable carpet options as much as possible. Consideration should be given to the sustainable importance of toxins that the yarn systems may or may not have, the backings used, and the potential for re-cycled or "post-consumable" content.
 - j. Carpet must be 100% recyclable.
 - k. The carpet manufacturer must have 100% closed loop recycling and offer free pick-up and recycling.
 - l. When selecting carpet materials, consider that the carpet will be cleaned only annually. Specify materials choices which provide substantial wear and soil hiding characteristics. Also consider that regular vacuuming will be accomplished with heavy duty equipment. Delicate carpet requiring special attention will not prove durable.
 - m. Limit color choices to those which will provide substantial wear and soil hiding characteristics. Restrict solid color carpet to accent areas. Do not use light colors.

- n. The color board: A sample of the proposed carpeting shall be included in the color board for each area. The UM Project Manager shall be responsible for identifying other approval parties for each application.
- o. The Design Professional shall provide specifications for tufted carpet including: face pile, construction, yarn, style, pile height, stitch rate, gauge, pile face weight, primary backing, secondary backing, width, total weight, manufacturer, carpet name, manufacturer's contact person and phone number, color, and anti-microbial performance.
- p. Carpet tile is preferred; Shaw / Patchcraft. Verify colors and patterns with University Architect.
- q. No pad applications allowed.

Product Standards

1. Selected carpet must meet requirements of CRI's "Green Label Plus" program.
2. The specifications shall include detailed construction, components, performance criteria and test data required to ensure conformance with these standards.
3. Carpeting Fire-Test-Response Characteristics: Select carpeting with the following fire-test-response characteristics as determined by testing identical products per test method indicated below by UL or another testing and inspecting agency acceptable to authorities having jurisdiction. Identify carpeting with appropriate markings of applicable testing and inspecting agency.
 - a. Critical Radiant Flux Classification: Not less than 0.45 W/sq. cm
4. The following are minimum requirements for carpet:
 - a. Specific optical density of 450 or less.
 - b. Maximum gray scale factor of 4 when tested for a period of 40 hours except as otherwise indicated.
 - c. Static Resistance: Minimum of 3.0 kV resistance for 20% R.H. at 70 degrees.
 - d. Average face yarn tuft bind of 20 lb. for "life of carpet" – wet or dry.
 - e. Solution dyed nylon with stain resistance.
 - f. Four-ply yarn
 - g. Style – Multi Level Loop or Level Loop
 - h. 1/8" gauge minimum
 - i. Pile face weight: minimum of 20 oz. for sheet carpet and minimum of 17 oz for carpet tile.
 - j. Density: Minimum 8000 for corridors, lobbies, libraries. Minimum 7000 for open office, conference and seminar rooms, minimum 6000 for private offices
 - k. Backing system: Sheet carpet: equal to Ecoworx Performance, Carpet Tile: equal to Ecoworx Tile
 - l. Roll Width of 12 feet for sheet carpet, 18", 24" or 36" square for carpet tile
 - m. Microbial resistance limited to minimum of 90 % bacterial reduction and maximum of 20% fungal growth.

5. Carpet Accessory Materials:
 - a. Adhesive: Low VOC, waterproof, of type that prevents growth of bacteria and fungus, as recommended and approved by carpet manufacturer for compatibility with carpet.
 - b. Seam Cement: Not required on unibond backing. When required use low VOC waterproof, latex type recommended by carpet manufacturer.
 - c. Edge Strips: Solid, resilient vinyl or metal; configuration and color to be selected by Design Professional from manufacturer's standard line.
 - d. Carpet Edge Guard: Rubber cove wall base color to be selected by Design Professional from manufacturer's standard line.
 - e. Floor patching compounds: As recommended by carpet manufacturer.
6. Color to be selected by Design Professional, and approved by the UMBS Committee.
7. Approved Manufacturer
 - a. Shaw/Patchcraft
8. Approved Installer
 - a. Ramon Carpet Service. (Verify with the UMBS Committee)

Performance Standards

1. Carpeting Installation
 - a. Request the concrete slabs receiving flooring be prepared according to ASTM F710.
 - b. Request that slab be tested for moisture content according to by flooring manufacturer printed instructions.
 - c. Primer may be required over concrete slab before flooring installation. Include text in specifications requiring verification from adhesive and carpet manufacturer.
 - d. Install carpeting in accordance with the manufacturer's printed installation instructions.
 - e. Do not proceed with installation of the carpeting until the building is enclosed and permanent heating and cooling equipment is installed and functioning.
 - f. Carpeting shall be installed continuously under demountable partitions.
 - g. Prior to beginning installation, the Design Professional shall review with the installer, edging techniques, lines of demarcation between carpeted and hard surfaced floor areas, edge treatment at doors and thresholds, and carpet seams.
 - h. In general, carpet must be installed using direct glue down method. For special applications at Faculty Residences or other areas requiring padding, follow manufacturer's recommendations for stretch-in installation.
2. Accessories Installation
 - a. Request that transition strips be installed where carpeting abuts other flooring including door openings where thresholds are not indicated. Where doors separate carpeted space from uncarpeted space, carpet shall extend under the door when it is in the closed position.

3. The Installer:
 - a. The UMBS Committee shall approve the installer, if the proposed installer is other than the firm currently under contract.
 - b. The Design Professional shall request evidence of the qualifications of the workers who will be installing carpet.
 - c. The installer's workers shall have a minimum of five years' experience on this type and size of installation and shall provide references of two similar installations that have been in use for a minimum of two years.
4. At project completion, the contractor shall furnish extra carpet materials to UM. The Design Professional shall determine the appropriate amounts based on the size of the project.
5. The Design Professional shall require product data, trade name or catalog numbers for carpet and accessories; material specifications including flame spread rating of carpet; adhesives; accessories; and printed installation instructions.
 - a. Documentation indicating compliance with testing and product requirements of CRI's "Green Label Plus" program shall be required.
 - b. A printed statement of VOC content information for installation adhesive and primer shall be required.
6. The Design Professional shall require shop drawings showing layout of seams, including carpet widths and directions, edge conditions, and conditions where joined or butted to adjacent materials.
7. The Design Professional shall require samples. The following are suggestions:
 - a. 18 in x 18 inch samples of carpet quality in full range of standard colors for selection. Identify sample with manufacturer's name and quality line.
 - b. 6-inch long samples of edge strip in full range of configurations and colors for selection.
 - c. 6-inch long samples of rubber base, in full range of configurations and colors for selection.
8. The Design Professional shall request carpet care and maintenance instructions. Include the following:
 - a. Description of cleaning methods and frequency of cleaning activities.
 - b. Description of each piece of equipment, tool and cleaning product used for the carpet maintenance program.
9. The Design Professional shall request the following certificates:
 - a. Certificate of Compliance: Submit carpet manufacturer's signed certificate stating that carpet supplied complies with the specifications requirements.
 - b. Critical Radiant Flux: Submit certification that carpet supplied passes specified Critical Radiant Flux Classification.
10. Carpet may be subject to testing by an independent testing laboratory to verify that minimum specification requirements have been met.

11. The Design Professional shall require the following warranties from the manufacturer:
 - a. Wear, static protection, backing delamination, edge ravel, and tuft bind. Terms and requirements as per the agreement with Shaw/Patchcraft. Note: chair pads are required .
12. The carpet shall be clean and undamaged at acceptance of project. Prior to Owners' acceptances the Design Professional shall verify compliance.
13. Request a maintenance manual from carpet manufacturer's including recommendations for the care, cleaning and maintenance of carpeting.

09 69 00 Access Flooring

Modular floor panels and support systems may be permitted only with UMBS Committee approval. If approved, modular steel stringer system designed to bolt to pedestal heads is preferred.

09 72 00 Wall Coverings

Design Standards

1. General: This section includes the criteria for the application of wall coverings, to include:
 - a. Heavy-duty, Non-Vinyl (PVC-free) synthetic wallcovering.
 - b. Heavy duty, synthetic, textile wallcovering
2. Wallcovering is considered a specialty type finish and is not standard in University work. Refer to the UM Interior Design Guidelines for areas where wallcovering is permitted.
3. Avoid vinyl (PVC) products.
4. Low-VOC adhesives are required.
5. Application of wall covering in interior face of exterior wall is not permitted.
6. Non-vinyl wall covering must meet the performance criteria established for the following vinyl wallcovering category: ASTM F793, Category V, Type II Serviceability or FS CCC-W-408D, Type II Duty. Use Type III Serviceability for heavy-duty synthetic textile wallcovering. Any deviations from these standards will require UM approval.
7. Select patterns and color that will enhance the area. Select a wall covering that is easy to clean and has low maintenance cost.
8. Select a random match type wall covering, if possible, to reduce waste.

9. Non-Vinyl wall covering must be inherently stain resistant. Synthetic textile wallcovering must be inherently stain resistant or treated with a stain resistant coating.
10. Heavy-duty, synthetic textile wallcoverings are composed of Xorel, polyester (recycled contents preferred), polyester blends, and olefin.
11. Provide wall coverings with the following surface-burning characteristics as determined by testing per ASTM E84.
 - a. Flame Spread: 25 or less.
 - b. Smoke Developed: 450 or less.

Products Standards

1. Products listed here are alternatives to non-vinyl wallcovering. UMBS Committee approval is required for use.
2. Non-vinyl, wallcovering: Designtex Duraprene wallcovering, Surface iQ wallcovering by Len-tex (Carnegie Fabrics or MDC wallcoverings)
3. Heavy-duty, synthetic textile wallcoverings: Carnegie Fabrics Xorel, Knoll, Maharam, Design-Tex, Wolf-Gordon, Eykon.
4. Specify adhesives that are mildew resistant, non-staining, non-flammable and low VOC type; compatible with substrate where it will be applied.

Performance Standards

1. The Design Professional shall require the following submittals:
 - a. Product data for each type of product specified. Include data on physical characteristics, durability, fade resistance, and flame resistance characteristics.
 - (1) Data for adhesives, documentation including printed statement of VOC content.
 - (2) Data for recyclable content.
 - b. Shop drawings showing location and extent of each wall covering type. Indicate seams and termination points.
 - c. Samples for initial selection in the form of manufacturer's color charts consisting of actual units or sections of units showing the full range of colors, textures, and patterns available.
 - d. Samples for verification in sets for each color, texture, and pattern specified, showing the full range of variations expected in these characteristics.
 - (1) Wall covering material: Full-width sample, not less than 36 inches long, from dye lot used for the work.
 - (a) Submit sample with specified treatments applied.
 - (b) Mark top and face of material.
 - (c) Show complete pattern repeat.

- e. Schedule of wall coverings using same room designations indicated on Drawings.
 - f. Product certificates signed by manufacturers of wall coverings certifying that their products comply with specified requirements.
 - g. Maintenance data for wall covering to include in the operation and maintenance manual.
 - h. Extra Stock: Request full-size units equal to 5 percent of amount of each type installed.
 - i. Mock-up sample to demonstrate seam workmanship.
2. Surface Preparation:
- a. Surfaces must be prepared in accordance with normally accepted industry standards to provide a substrate suitable for the long term adhesion of specified coverings.
 - b. If surfaces cannot be properly prepared for finishing by specified methods, the UMBS Committee shall be notified immediately in writing and work shall not proceed unless directed to by the UMBS Committee. Failure to notify UMBS would mean that the Contractor assumes the responsibility for such surfaces and for rectifying any unsatisfactory results.
 - c. The Design Professional shall ensure that the installer is required to provide a sanitized surface, free of mold or mildew spores prior to applying any covering to any surface. Ensure that installer does not begin installation until space is enclosed and waterproof. Require that surfaces receive a suitable primer under Painting Section, before application of wall covering.
 - d. Request that wall covering installer coordinates applications of wall primer on receiving substrates with painting work.

09 75 13 Stone Paneling

The use of dimension stone interior wall paneling may be permitted only with the UMBS Committee approval.

09 75 16 Stone Base

The use of dimension stone interior wall base may be permitted only with the UMBS Committee approval.

09 75 19 Stone Trim

The use of dimension stone interior trim may be permitted only with the UMBS Committee approval.

09 75 23 Stone Window Stools

The use of dimension stone interior window stools may be permitted only with the UMBS Committee approval.

09 77 13 Stretched-Fabric Wall Systems

The use of site assembled and upholstered fabric wall systems may be permitted only with the UMBS Committee approval.

09 77 23 Fabric-Wrapped Panels

The use of shop-fabricated, fabric-wrapped, decorative and tackable wall panels, not tested for acoustical performance, may be permitted only with the UMBS Committee approval.

09 84 33 Sound-Absorbing Wall Units

The use of sound-absorbing, sound-diffusing, and sound-reflecting wall panels, tested for acoustical performance is permitted.

09 84 36 Sound-Absorbing Ceiling Units

The use of shop-fabricated, fabric-wrapped, sound-absorbing, sound-diffusing, and sound-reflecting panels and sound-absorbing baffle panels applied to or suspended from the ceiling is permitted.

09 91 00 Interior and Exterior Painting**Design Standards**

1. General: This section includes the criteria for cleaning, preparation, substrate repair, caulking, sealing and painting of:
 - a. Existing and new exterior surfaces
 - b. Existing and new interior surfaces
 - c. UMBS criteria
2. The Contract Documents must include a paint schedule.
3. Existing surfaces shall be tested to determine if lead is present. Should lead be present, the UMBS Committee shall be contacted immediately for abatement procedures to be used prior to proceeding with work.
4. All exposed surfaces shall be painted, except where otherwise indicated in the paint schedule. Do not paint prefinished items, finished metal surfaces, operating parts or labels.
5. Include provisions for the trimming and/or removal of all foliage clinging to, or otherwise obstructing the buildings, to permit access to the areas to be painted.

6. Surface Preparation:
- a. Surfaces must be prepared in accordance with normally accepted industry standards and painting manufacturer's published recommendations to provide a substrate suitable for the long term adhesion of specified coatings. Proper preparation is the responsibility of the contractor.
 - b. If surfaces cannot be properly prepared for finishing by specified methods, the UMBS Committee shall be notified immediately in writing and work shall not proceed unless directed to by UM. Failure to notify would mean that the Contractor assumes the responsibility for such surfaces and for rectifying any unsatisfactory results.
 - c. The Contractor shall be required to provide a sanitized surface, free of mold or mildew spores prior to applying any coating to any surface.
 - d. The complete removal of existing paint is not always required nor desired. Pressure cleaning is an acceptable solution. Consult with the paint/coating manufacturer.
 - e. The following recommendations for substrate preparation are being provided for guidance only and should not be considered all inclusive. Contractor should be required to follow printed manufacturer's recommendations. Where painting is scheduled over existing damaged surfaces, contractor should be required to seek assistance from the paint manufacturer, including but not limited to site inspection and testing and written recommendations for surface preparation.
 - (1) Exterior Metal:
 - (a) Remove all rust and contaminants. Surfaces with a hard glossy finish shall be dulled by sandpaper or other abrasive method to ensure adhesion of succeeding coats.
 - (b) Prime all bare metal with appropriate primer.
 - (c) Clean galvanized surfaces with non-petroleum solvents.
 - (e) The painting work shall include the field painting of exposed bare and covered pipes and ducts, including color coding, hangers and exposed metal surfaces of mechanical and electrical equipment.
 - (2) Exterior Wood:
 - (a) Remove all loose, peeling, blistering, flaking paint, chalk, and contaminants by scrapping or sanding. Surfaces with a hard glossy finish shall be dulled by sandpaper or other abrasive method to ensure adhesion of succeeding coats.
 - (b) All cracks and holes shall be filled with an appropriate filler material. Spot prime and sand prior to finish coat.
 - (c) If the old paint is in good condition, exterior wood primer may be eliminated.
 - (3) Exterior masonry:
 - (a) Remove mildew by washing surfaces with a diluted bleach solution. If dirt or grime is also present, add detergent to the solution. Flush with water.
 - (b) Remove all loose, peeling, blistering, flaking paint, chalk, and contaminants by scrapping, wire brushing, sanding or water blasting.

- (c) All loose and broken stucco must be removed, bonded and repaired/patched to match existing. All cracks, including hairline cracks, must be cleaned out, sealed and repaired with an approved sealant/patching compound.
 - (4) Plaster:
 - (a) Phase projects to allow stucco/plaster surfaces and cast-in-place concrete to properly cure prior to painting.
 - (5) Joint Sealant/Caulking: All loose, missing, or deteriorated sealant / caulking around exterior windows and doors shall be cleaned out. The joints shall be primed and re-sealed with a top quality silicone joint sealant, prior to the application of the paint.
- 7. Application:
 - a. Apply paints only within the manufacturer's recommended temperature ranges.
 - b. Mix and prepare materials according to manufacturer's written instructions.
 - c. Tint each undercoat a lighter shade to simplify identification of each coat.
 - d. Apply paints and coatings by brush, roller, or other applicators according to manufacturer's instructions. Spray applications shall be scheduled around business hours, and appropriate care must be taken to insure that vehicles and other property are not damaged by the spray.
 - e. Specify paint coats no thinner than the manufacturer's recommended spreading rates.
 - f. Apply the first coat to surfaces that have been cleaned, pretreated or otherwise prepared as soon after preparation has been completed.
 - g. All new and existing work shall be properly primed prior to painting.
- 8. Acceptable colors: Select colors from the UMBS Committee's approved paint colors. Avoid the use of dark or bright colors on exterior surfaces and other surfaces exposed to ultraviolet light.
 - a. Refer to excerpt from the UMCAD guidelines (Page 35) related to 'Exterior Wall Color Palette' included at the end of this section.
- 9. Acceptable products: Only latex based enamels can be used in new applications. Existing oil base painted surfaces shall be prepared to receive new latex based paints. Any exception requires approval by the UMBS Committee.
- 10. Acceptable finishes:
 - a. Eggshell refers to low-sheen finish with a gloss range of 20 to 30 when measured on a 60-degree meter.
 - b. Flat sheen refers to a low-sheen with a gloss range of less than 15 on a 60-degree meter.
 - c. Semi-gloss refers to medium-sheen finish with a gloss range between 30 and 65 when measured at a 60-degree meter.
 - d. Satin finish shall not be used.
 - e. Use an elastomeric paint system over existing previously painted stucco surfaces; strictly follow manufacturer's instructions; sheen/finish should match other existing finishes; obtain UMBS Committee's approval.

- f. Minimum Dry Film Thickness: 5 mills, unless otherwise recommended by paint manufacturer.
11. All paints used shall comply with current GBC VOC criteria.

Products Standards

1. MPI Standards: Specify products that comply with MPI standards and that are listed in its "MPI Approved Products List."
2. Specify materials that comply with VOC limits of authorities having jurisdiction.
 - a. For interior paints and coatings the following VOC limits, exclusive of colorants added to a tint base, when calculated according to 40 CFR 59, Subpart D (EPA Method 24).
 - (1) Flat Paints and Coatings: 50 g/L.
 - (2) Nonflat Paints and Coatings: 150 g/L.
 - (3) Primers, Sealers, and Undercoaters: 200 g/L.
3. Approved manufacturers:
 - a. Sherwin Williams Co.
 - b. Benjamin Moore & Co.All other manufacturers will require University of Miami Building Standard Committee (UMBSC) approval.
4. Obtain block fillers, primers, and undercoat materials from the same manufacturer as the finish coats.
5. Furnish UM with an additional 5% of each material and color applied.
6. The following product selection is provided as a guideline only and is to be used to establish a minimum quality standard. The list is not intended to be all inclusive as it pertains to surfaces or products. The Design Professional is responsible for specifying the correct product for the intended application and updating the information contained herein. The Design Professional shall investigate and specify in accordance with the specific conditions found at the particular site.

Exterior Paint Schedule:

- a. Concrete, Stucco, and Masonry (Other than Concrete Masonry Units):
Provide the following finish systems over new, exterior concrete, stucco, and brick masonry surfaces:
 - (1) Flat, Acrylic-Enamel Finish: Two finish coats over primer.
 - (a) Primer:
 - (1) Loxon Concrete & Masonry Primer Interior/ Exterior Latex, A24W8300.
 - (b) First and Second Coats:
 - (1) Resilience Exterior Latex Flat, K42 Series (2 Coats).

- b. Concrete Masonry Units: Provide the following finish systems over new, exterior concrete masonry units:
 - (1) Semi-Gloss, Acrylic-Enamel Finish: Two finish coats over a block filler/primer.
 - (a) Block Filler/ Primer Alkaline Resistant: High-performance, latex block filler applied at spreading rate and mil thickness recommended by the manufacturer.
 - (1) Loxon Block Surfacer, A24W200 Series.
 - (b) First and Second Coats: Semi-gloss, exterior, acrylic-latex enamel applied at the spreading rate and mil thickness recommended by the manufacturer.
 - (1) Resilience Exterior Latex Gloss, K44 Series (2 coats)
- c. Wood Trim: Provide the following finish systems over exterior wood trim:
 - (1) Medium-Shade, Semi-gloss, Acrylic-Enamel Finish: Two finish coats over a primer.
 - (a) Primer: Exterior, acrylic-latex primer applied at the spreading rate and mil thickness recommended by the manufacturer.
 - (1) PrepRite ProBlock Interior / Exterior Latex Primer Sealer, B51.
 - (b) First and Second Coats: Semi-gloss, waterborne, exterior, acrylic-latex enamel applied at the spreading rate and mil thickness recommended by the manufacturer.
 - (1) Resilient Exterior Latex Gloss, K44 Series (2 coats).
- d. Ferrous Metal: Provide the following finish systems over exterior ferrous metal. Primer is not required on shop-primed items.
 - (1) Gloss, Water based Urethane Finish: Two finish coats over a rust-inhibitive primer
 - (a) Primer: Rust-inhibitive metal primer applied at the spreading rate and mil thickness recommended by the manufacturer.
 - (1) Pro Industrial Pro-Cryl Universal Primer, B66-310 Series.
 - (b) First and Second Coats: Gloss, exterior, Water based Urethane applied at the spreading rate and mil thickness recommended by the manufacturer.
 - (1) Hydrogloss Single Component Water based Urethane Gloss, B65 Series (2 coats).
- e. Aluminum: Provide the following finish systems over exterior aluminum surfaces:
 - (1) Gloss, Water based Urethane Finish: Two finish coats over primer.
 - (a) Primer: Rust-inhibitive, acrylic or alkyd-based, metal primer, as recommended by the manufacturer for use over aluminum, applied at spreading rate and mil thickness recommended by the manufacturer.
 - (1) Pro Industrial Pro-Cryl Universal Primer, B66-310 Series.
 - (b) First and Second Coats: Gloss, exterior, Water based Urethane applied at the spreading rate and mil thickness recommended by the manufacturer
 - (1) Hydrogloss Single Component Water based Urethane Gloss, B65 Series (2 Coats).

Interior Paint Schedule

- a. Concrete and Masonry (Other than Concrete Masonry Units):
 - (1) Semi-gloss, Acrylic-Enamel Finish: Two finish coats over primer.
 - (a) Primer: Alkali-resistant, acrylic-latex, interior primer applied at the spreading rate and mil thickness recommended by the manufacturer.
 - (1) Loxon Concrete & Masonry Primer Interior/ Exterior Latex, A24W8300.
 - (b) First and Second Coats: Semi-gloss, acrylic-latex, interior enamel applied at the spreading rate and mil thickness recommended by the manufacturer.
 - (1) ProMar 200 Zero VOC Interior Latex Semi-Gloss, B31-2600 Series (2 coats).
- b. Concrete Masonry Units:
 - (1) Semi-gloss, Acrylic-Enamel Finish: Two finish coats over a block filler.
 - (a) Block Filler: High-performance, latex-based, block filler applied at the spreading rate and mil thickness recommended by the manufacturer.
 - (1) Loxon Block Surfacer, A24W200 Series.
 - (b) First and Second Coats: Semi-gloss, acrylic-latex, interior enamel applied at the spreading rate and mil thickness recommended by the manufacturer.
 - (1) ProMar 200 Zero VOC Interior Latex Flat, B30-2600 Series (2 coats).
- c. Gypsum Board: Provide the following finish systems over new, interior gypsum board surfaces:
 - (1) Eggshell, Acrylic-Enamel Finish: Two finish coats over a primer. (Use Semi-Gloss Pro Industrial Pre-Catalyzed Water based Epoxy, K46 Series (Two Coats over primer) at Toilets and Kitchen areas. Use flat finish on ceiling surfaces only).
 - (a) Primer: Latex-based, interior primer applied at spreading rate and mil thickness recommended by the manufacture.
 - (1) ProMar 200 Zero VOC Interior Latex Primer, B28-W2600.
 - (b) First and Second Coats: Eggshell, acrylic-latex, interior enamel applied at spreading rate and mil thickness recommended by the manufacturer.
 - (1) ProMar 200 Zero VOC Interior Latex Flat, B30-2600 Series (2 coats).
- d. Gypsum or Portland Cement Plaster: Provide the following finish systems over new, interior plaster surfaces:
 - (1) Flat, Acrylic-Enamel Finish: Two finish coats over a primer. (Use Semi-Gloss Pro Industrial Pre-Catalyzed Water based Epoxy, K46 Series (Two Coats over primer) at Toilets and Kitchen areas).
 - (a) Primer: Alkali-resistant, alkyd- or latex-based, interior primer, as recommended by the manufacturer for this substrate, applied at spreading rate and mil thickness recommended by the manufacturer.

- (1) Loxon Concrete & Masonry Primer Interior / Exterior Latex, A24W8300.
 - (b) First and Second Coats: Flat, acrylic-latex, interior enamel applied at spreading rate and mil thickness recommended by the manufacturer.
 - (1) ProMar 200 Zero VOC Interior Latex Flat, B30-2600 Series (2 coats).
- e. Woodwork and Hardboard: Provide the following paint finish systems over new, interior wood surfaces:
 - (1) Semi-gloss, Acrylic-Enamel Finish: Two finish coats over a wood undercoater.
 - (a) Undercoat: Alkyd or acrylic-latex-based, interior wood undercoater, as recommended by the manufacturer for this substrate, applied at the spreading rate and mil thickness recommended by the manufacturer.
 - (1) PrepRite ProBlock Interior / Exterior Latex Primer Sealer, B51 Series.
 - (b) First and Second Coats: Semi-gloss, acrylic-latex, interior enamel applied at the spreading rate and mil thickness recommended by the manufacturer.
 - (1) Pro Industrial Zero VOC Acrylic Semi-Gloss, B66-650 Series (2 coats).
- f. Ferrous Metal: Provide the following finish systems over ferrous metal:
 - (1) Semi-Gloss, Water based Epoxy finish: One finish coat over a primer.
 - (a) Primer: Quick-drying, rust-inhibitive, Waterborne Universal Primer, as recommended by the manufacturer for this substrate, applied at the spreading rate and mil thickness recommended by the manufacturer.
 - (1) Pro Industrial Pro-Cryl Universal Primer, B66-310 Series.
 - (b) Undercoater: Semi-Gloss Water based Epoxy finish, as recommended by the manufacturer for this substrate, applied at the spreading rate and mil thickness recommended by the manufacturer.
 - (1) Pro Industrial Pre-Catalyzed Water based Epoxy Semi-Gloss, K46 Series (2 coats).
 - (c) Finish Coat: Semi-Gloss Water based Epoxy finish, as recommended by the manufacturer for this substrate, applied at the spreading rate and mil thickness recommended by the manufacturer.
 - (1) Pro Industrial Pre-Catalyzed Water based Epoxy Semi-Gloss, K46 Series (2 coats).

Performance Standards

1. The Design Professional shall require the following submittals:
 - a. Product data for each paint system specified.
 - b. VOC content of each primer and paint required.
 - c. Samples for initial selection and verification.
 - d. Mock-ups. One room or surface shall be selected to represent surfaces and conditions for each type of coating and substrate to be painted. Final approval of colors shall be from job-applied samples and require UM acceptance.
2. The Contractor shall have insurance covering liability and property damage, and workers compensation coverage.
 - a. The contractor shall hold UM harmless from all liens or damage arising from or caused by this work.
3. The applicator shall be licensed in Miami-Dade County and shall demonstrate at least five years of experience in projects of similar size and scope.
4. The Design Professional and the Contractor shall coordinate with UM for the requirements for a staging area.
5. The Design Professional and the Contractor shall coordinate with UM to notify all occupants of the property to remove any personal items, patio furniture and vehicles.
6. Delivery: Materials shall be delivered to the site in manufacturer's original, unopened packages bearing the manufacturer's name and label. Store materials in tightly covered containers.
7. Field Quality Control:
 - a. The UMBS Committee reserves the right to engage the services of an independent testing agency to sample the paint material to be used. The Contractor may be required to remove any rejected paint work.
 - b. Hardware and accessories that are not to be painted shall be removed. If removal is not feasible, provide surface applied protection. Reinstall immediately upon completion of the paint work.
8. Cleaning: The Design Professional shall require that at the end of each working day, all equipment, ladders, paint, supplies, etc. be returned to the staging area and the working area shall be left clean.
9. Warranty: Ten-year manufacturer's warranty for labor and material. Include in the specifications that the manufacturer is to assume responsibility for substrate acceptance and adhesion and to uphold the required warranty.
10. Completed work shall be protected. Provide 'Wet Paint' signs. Touch up and restore damaged surfaces. Remove temporary wrappings.

09 93 00 Staining and Transparent Finishing

This finish shall be factory applied.

09 94 19 Multicolor Interior Finishing

The use of speckled finishes on interior vertical surfaces may be permitted only with UMBS Committee approval.

09 96 00 High-Performance Coatings

The use of tile-like epoxy coatings on interior substrates may be permitted only with UMBS Committee approval.

09 96 33 High-Temperature-Resistant Coatings

The use of high-temperature-resistant coatings on exterior and interior substrates may be permitted only with UMBS Committee approval.

09 96 53 Elastomeric Coatings

The use of exterior waterborne, pigmented, elastomeric coatings over concrete, masonry, and stucco substrates may be permitted only with UMBS Committee approval.

09 97 26 Cementitious Coatings

The use of polymer-modified cementitious coatings on masonry and concrete substrates (exterior and interior) may be permitted only with UMBS Committee approval.

DIVISION 10 – SPECIALTIES

This chapter identifies criteria for the selection and design of specialties with the purpose of establishing minimum standards, acceptable to UM, to be used as the basis of design for UM Coral Gables campus buildings.

- 10.1 General Requirements.
 - 10.1.1 Submittals
 - 10.1.2 Workmanship Requirements
- 10.2 Codes
- 10.3 Standards
- 10.4 Design Criteria
- 10.5 Specific Requirements (Organized by CSI Master Format 2012 Number and Titles)

10.1 General Requirements

The design, use and implementation of specialty equipment shall be provided in a manner to foster an efficient environment for the users and should be considered with the following objectives:

1. Cost
2. Life cycle
3. Longevity
4. Aesthetics
5. Maintenance
6. Warranty
7. Occupant Safety

Quality of the information, materials, shop drawings, reviews, equipment integrity, completeness and installation shall be a major concern. All specialty components are intended for long term usage for the general public designed with specific emphasis for the occupants, disabled and custodial use.

10.1.1 Submittals

Submittal shall include product data, shop drawings, samples and closeout submittals as defined in applicable specification sections.

10.1.2 Workmanship Requirements

Refer to specific requirements included herein.

10.2 Codes

1. Florida Building Code (FBC)
2. Florida Department of Community Affairs-Florida Accessibility Code for Building Construction (DCA)
3. American with Disabilities ACT (ACT), Accessibility Guide Lines for Building and Facilities, and Architectural Barriers (ABA) Accessibility
4. American Disabilities Act of Accessibility Guidelines (ADAAG)
5. American Society of Civil Engineers (ASCE 7)
6. National Electric Code (NEC)
7. National Fire Protection Code (NFPA)
8. Underwriters Laboratory (UL)
9. City of Coral Gables, Local Codes and Ordinances

10.3 Standards

1. UM special requirements and experience with various manufacturers, products and installations have led to adopted procedures and practices which have been incorporated into these standards.
2. Specific product manufacturer requirements.
3. The Design Professional shall coordinate signage designs, usage and align design signage using University of Miami “Campus Interior Sign Design Standards”. These standards supersede requirements listed under this building standard should conflict occurs. Refer to website link for additional information and coordination.

University of Miami “Campus Interior Sign Design Standards”

LINK:

[https://umshare.miami.edu/web/wda/ref/Signage/UM Interior Sign Standards ver1 %5B1%5D.pdf](https://umshare.miami.edu/web/wda/ref/Signage/UM%20Interior%20Sign%20Standards%20ver1%5B1%5D.pdf).

10.4 Design Criteria

Refer to specific requirements under each section included herein.

10.5 Specific Requirements (Organized by CSI Master Format® 2012 Numbers & Titles)

10 11 00	Visual Displays Units
10 12 00	Display Cases
10 13 00	Directories
10 14 16	Plaques

10 14 19	Dimensional Letter Signage
10 17 00	Telephone Specialties
10 21 13	Toilet Compartments
10 21 16	Shower and Dressing Compartments
10 21 23	Cubicles
10 22 13	Wire Mesh Doors and Partitions
10 22 19	Demountable Partitions
10 22 39	Folding Panel Partitions
10 26 00	Wall And Door Protection
10 28 00	Toilet Room Accessories
10 43 00	Emergency Aid Specialties
10 44 13	Fire Protection Cabinets
10 44 16	Fire Extinguishers
10 51 13	Metal Lockers
10 55 00 13	USPS Delivery Postal Specialties
10 55 00 16	Private Delivery Postal Specialties
10 56 13	Metal Storage Shelving
10 56 26	Mobile Storage Shelving
10 73 13	Awnings
10 75 00	Flagpoles
10 83 16	Banners

10 11 00 Visual Display Units

1. Visual display units include chalkboards, marker boards, tack boards, and bulletin boards in cabinets.
2. For all chalkboards and marker boards, a lifetime warranty is required that indicates that under normal usage and maintenance, porcelain enamel steel chalkboards are guaranteed for the life of the building. Failure will include the surface loss of writing and erasing capability and/or the chalkboard exhibiting surface crazing, cracking and flaking.
3. Develop a schedule listing sizes, types, mounting heights and methods, colors, number of markers, and other accessories. This schedule shall be used for coordinating design, program requirements, built-ins, and FF&E locations.
4. Typical mounting heights – the height from the top of the finished floor to the bottom edge of instructional boards shall be as follows:
 - a. 2'-9" at instructional areas to caulk tray, with an overall 4'-0" foot board height.
 - b. 3'-0" at staff areas to chalk tray, with an overall 4'-0" foot board height.
 - c. 6'-0" for electronic mounting heights to the top of marker board.
5. Instructional boards shall be located at least 24 inches from room corners.

6. Size and locate Instructional boards according to UM program requirements. All locations and dimension of units are to be field verified prior to installation.
7. Writing surfaces shall be seamless and continuous.
8. Chalkboards shall be delivered factory assembled. The writing surface shall be matte finish green vitrified porcelain over 24 gage enameled steel with primer, ground coat and cover coats fused individually. Chalkboards shall be manufactured in accordance to PEI (Porcelain Enamel Institute) specifications. Coat concealed faces with primer and ground coats. Core materials shall be on 7/16" hardboard with 0.015" aluminum backing and 1" wide satin finished aluminum trim with concealed fasteners. Writing surfaces shall be seamless and continuous. Components shall have an ASTM E 84 Class III flame spread rating Index 25. Provide rounded corners on the product.
9. Marker boards shall be delivered factory assembled. The writing surface shall be a low gloss finish white vitrified porcelain over 24 gage enameled steel primer, ground coat and cover coats fused individually. Marker boards shall be manufactured in accordance to PEI (Porcelain Enamel Institute) specification. Coat concealed faces with primer and ground coats. Core materials shall be 7/16" hardboard with 0.015" aluminum backing and 1" wide satin finished aluminum trim with concealed fasteners. Components shall have ASTM E 84 Class III flame spread rating Index 25. Provide rounded corners on the product.
10. Electronic Marker boards shall be delivered factory assembled. Provide the manufacturer's standard electronic marker board that consists of touch-sensitive writing surface connected to microcomputer via RS-232 serial cable and that electronically records writing with standard dry-erase markers. Equip unit with cables, software, pens, erasers, mounting hardware, and accessories required for a complete installation. Provide rounded corners on the product.
11. Electronic Marker boards shall have manufacturer provides software with real time recording and printing everything that is written and drawn on electronic marker board with a windows based operating system and have the following features:
 - a. File Export Formats: BMP, WMF, HTML, and vector-based formats.
 - b. Compatibility: Compatible with Microsoft NetMeeting or other T.120-compliant software.
 - c. Features: Capable of the following:
 - (1) Saving directly from screen.
 - (2) Erasing portions of screen.
 - (3) Printing directly from screen.
 - (4) Saving individual screens as separate pages.
 - (5) Showing onscreen toolbar or keyboard per UM requirements
 - (6) Recognizing not less than four pen colors.
 - (7) Recognizing finger touch control for presentations.

- (8) Connecting multiple electronic marker boards to a single computer.
 - (9) Showing online help and tutorial.
12. Electronic marker boards shall contain a manufacturer's standard agreement where the manufacturer shall repair or replace electronic marker boards that fail in materials or workmanship within specified warranty period of two years.
 13. Tack boards shall be delivered factory assembled. Tack boards shall have seamless cork surfaces, burlap backed, over 1/4" hardboard with 0.015" aluminum backing and 1" wide satin finished aluminum trim and have an ASTM E 84 Class III flame spread rating Index 25. Provide rounded corners on the product.
 14. Horizontal sliding instructional boards shall have a fixed tack board back panel and 2 tracks for a combination of 4 sliding chalkboards/marker boards.
 15. Chalk/marker boards are to have troughs with protective edge guards.
 16. Provide a 1 inch high continuous map rail, with a cork insert, at the top edge of the instructional board assembly and include the following:
 - a. One pair of map hooks for each 8 feet of map rail length and fraction thereof at all board locations.
 - b. One pair of roller brackets at each instructional board.
 - c. Two flag holder brackets per instructional space.
 17. Projection screens shall be wall mounted and not attached to instructional boards.
 18. Bulletin board cabinets shall be surface mounted, lockable, with clear satin finish anodized aluminum frames and tempered or laminated glass doors. Lexan is not allowed. Locate only in secured and supervised areas.
 19. Provide proper wall construction/backing to support instructional board units. Provide shop drawings for each unit type for UMBS Committee approval.
 20. Particleboard and fiberboard backings are not allowed.
 21. Do not locate instructional boards on operable partitions, unless no other walls are available for use.
 22. The following finish criteria shall be followed:
 - a. Comply with NAAMM's "Metal Finishes Manual for Architectural and Metal Products" for recommendations for applying and designating finishes.
 - b. Protect mechanical finishes on exposed surfaces from damage by applying a strippable, temporary protective covering before shipping.

- c. Appearance of Finished Work: Noticeable variations in same piece are not acceptable. Variations in appearance of adjoining components are acceptable if they are within the range of approved samples and are assembled or installed to minimize contrast.

10 12 00 Display Cases

1. Provide a schedule listing sizes, types, mounting heights and methods, colors, number of markers, and other accessories. This schedule shall be used for coordinating design, program requirements, built-ins, and FF&E locations.
2. Display cases may be either recessed or surface mounted. Provide a factory-fabricated cabinet unit with 3/8" natural cork or fabric / polyester covered tack board assembly on rear inside surface, adjustable 6mm tempered glass shelves, operable 6 mm thick glazed tempered sliding weather-stripped glass doors and cylinder lock with two keys, front illuminated or non-illuminated. Recessed display cases shall have trim on face to cover edge of recessed opening. Cases shall have an ASTM E 84 Class III flame spread rating Index 25 sized to UM requirements. Provide rounded corners on the product.
3. Display cases product specifications, accessory items, colors, finishes, applications and details shall be reviewed and approved by UM prior to the final development of the construction documents.
4. The display cases shall be integrated into the architectural design of the building and be located in public corridors and lobbies. Actual dimensions of openings for display cases are to be field verified prior to fabrication.
5. The following finish criteria shall be followed:
 - a. Comply with NAAMM's "Metal Finishes Manual for Architectural and Metal Products" for recommendations for applying and designating finishes.
 - b. Protect mechanical finishes on exposed surfaces from damage by applying a strippable, temporary protective covering before shipping.
 - c. Appearance of Finished Work: Noticeable variations in same piece are not acceptable. Variations in appearance of adjoining components are acceptable if they are within the range of approved Samples and are assembled or installed to minimize contrast.
6. Display cases shall be weather tight.

10 13 00 Directories

1. Provide a schedule listing sizes, types, mounting heights and methods, finishes, colors, number of markers, and other accessories. This schedule shall be used for coordinating design, program requirements, built-ins, and FF&E locations and overall building design.
2. Directories product specifications, accessory items, colors, finishes, applications and details shall be reviewed and approved by the UMBS Committee prior to the final development of the construction documents.
3. Provide building directories unit consisting of changeable message strips held in place by retainer frame enclosed in manufacturer's standard 1-1/2" to 2" deep perimeter frame; with aluminum-sheet rear cover panel and glazed cover. Coordinate with the UMBS Committee to determine if an illuminated or non-illuminated unit should be used near the main entrance(s) of each building. The construction, style and appearance shall be coordinated with the building signage. The units shall have an ASTM E 84 Class III flame spread rating Index 25 and be weather resistant. Provide security fasteners where exposed to view.
4. Provide directories that shall withstand the effects of gravity loads and loads and pressures as defined by ASCE 7 requirements.
5. Provide maintenance manuals for all illuminated directories. All illuminated directories shall comply with NFPA 70 requirements.
6. Provide a 6'-0" for mounting height from finished floor to top of directory.

10 14 16 Plaques

1. This section includes dedication, memorial plaques, and USGBC LEED plaques standards when utilized, in new or renovated buildings. Provisions shall be made for a wall area in the main lobby or in the vestibule to the main lobby to be used for the installation of a memorial plaque. The wall area shall be architecturally designed to provide an aesthetic setting for the plaque and shall be adequately illuminated. Consult with the UMBS Committee to verify if the plaque is to be part of the construction documents or will be provided at a future date. Provide sufficient blocking or other materials to support plaque as part of the construction documents.
2. Personal memorial, donor recognition, and room plaques shall be designed and installed based on the space they are to be displayed in. Be aware of and make provisions (space, applicable blocking, utilities and lighting) in the building for donor recognition areas and room plaques.
3. Provide additions, when requested by University of Miami with a 14 inch by 20 inch high cast

- bronze plaque under ASTM B584 requirements, located near the main administration entrance or appropriate addition entry, to include the following:
- a. The names of the University Board Members and the President of the University in office the day the construction contract was awarded.
 - b. The year the construction contract was awarded.
 - c. The names of the project architect and the general contractor.
4. Building name if applicable.
 5. Provide minimum 6 to 8 inch high cast bronze letters. Building name are dependent on the buildings architecture, proportion and location. Address numbers located on "front" elevation of the facility and legible from the public right of way. Final building identifications shall be reviewed and approved by UMBS Committee.
 6. Cast plaques background texture, border and characters having a uniform face, sharp corners, and precisely formed lines and profiles as requested by University of Miami. Submittal shall be reviewed and approved prior to fabrication.
 7. USGBC LEED Plaque Guidelines:
 - a. The main objective is for the LEED certification mark to appear tone-on-tone, in a color of a natural material, i.e. stone, glass with no additional contrasting color added. The plaque can be attached to an existing surface, or it can be mounted as a plaque as a piece of stone, or disc of metal, etc. The UMBS Committee should be contacted for a determination of material selection prior to order, fabrication and delivery.
 - b. Techniques used to achieve a tone-on-tone finish can include: sandblasting, etching not involving toxic chemicals, or frosted vinyl applied on glass. In all finishes enough contrast must be achieved in order to clearly distinguish the logo as legible.
 - c. Size: No smaller the 16" inches in diameter unless otherwise approved by UMBS Committee.
 - d. USGBC Approved Fabricators: All USGBC LEED signage plaque must be manufactured by a USGBC approved manufacturer.

10 14 19 Dimensional Lettering Signage

1. UMBS Committee has a standardized system for all campus room numbering and signage. Follow the requirements outlined in the attached UMBS Committee signage package with respect to size, color, format, fonts, and materials for the construction documents and the development of all room numbers and signage for the project. All submittals require the approval by the UMBS Committee prior to completion of the construction documents. All signage and graphic designs in public spaces or on the exterior of any structure must be approved by the UMBS Committee prior to completion of construction documents.

2. Interior signage for new buildings, fully renovated buildings, or a fully renovated floor of the building shall comply with current ADA Accessibility Guidelines for building and facilities and NFPA codes, as well as with these standards. In locations where a small renovation is occurring or a small number of signs are needed, it is typically appropriate to conform to the existing sign system in the building and not to conform to these standards.
3. Permanent room numbering to appear on signs shall be fully incorporated into the construction documents for the use by the contractor. Each permanent room number shall be unique and consistent with UMBS Committee standards.
 - a. Floor Designations - For buildings that have multiple at grade entrances levels, the lowest accessible at grade will be designated "Ground Floor". For buildings that have a single floor at grade level, that will be designated "Level One". Floors below the lowest floor at grade level will be designated "Basement, Sub-Basement and Sub-Sub Basement". Floors above will be designated numerically in order starting with Level One. If there is a partial or secondary level between those primary levels it will be designated intermediate to the level directly below.
 - b. Permanent Room / Space Numbering Sequence- Room numbering on each floor will be similar to the method used to assign address on a street, odd numbers on left, even numbers on the right in the direction of ascension. This provides a sense of direction or movement from one end of the building to the other. Gaps in the numbering will occur so that the numbering sequence across a corridor is always ascending. For example if there are four rooms on the left before there is a room on the right on Level 1, the left hand rooms would be numbered 101, 103, 105, and 107. The right hand room would be numbered 108 even though it is the first room on that side of the corridor. A series of large rooms should also include gaps for future subdivisions, similar to street numbering.
Nested rooms (rooms not directly on a corridor, which are entered from another room) will have the same room number as the lowest numbered room they are entered from, plus a letter suffix designated in a clockwise sequence around the room. An example is room 108A is off of room 108, room 108B is off 108A. Each building shall be reviewed separately to determine where it is best to start the numbering sequence so that it progresses across the floor as a continuous numbering string. Wing designations are to be used only when numbering would require numbers higher than 99 or where a continuous numbering string is not practical.
 - c. Non-assignable Space such as Corridors, Stairs, Vestibules, Elevators, etc.- these spaces shall be designated 00 with the following suffixes: CR* (corridor), ES* (elevator shaft), LB* (lobby), ST* (stairway), VS* (vestibule). The * indicates a letter to differentiate between similar types of spaces on each floor. An example is corridor on level 2 would be designated 200CRA; a second corridor on that floor would be 200 CRB.

4. Sign company shall provide to the UMBS Committee the software and database(s) to install on UM's computer, and paper (7A-D) to allow the University to produce replacement inserts for each insert size and type.
5. A single manufacturer should provide signs in a specific style. Signs shall be mounted with concealed fasteners or adhered to background as indicated. Mounting height and relationship to doorways should follow.
6. All locations and dimension of all units shall be field verified prior to installation.
7. All Identifying signage shall comply with the following:
 - a. Americans with Disabilities Act and Accessibility Guidelines (ADA)
 - b. Florida Department of Community Affairs - Florida Accessibility Code for Building Construction (DCA).
 - c. National Fire Protection Code (NFPA).
 - d. Other applicable codes.
8. Signage
 - a. Accessibility signage, room identification, and life safety signage shall have and raised characters, Braille, and symbols to comply with ADA standards.
 - b. Provide signage schedule and location plan in final construction document submittal.
 - c. Provide raised image laminated plastic interior and exterior signage, in compliance with ADA guidelines, program and code requirements; include the following:
 - (1) UM signage standards with raised upper case font style per UM signage standards type letters for room names and room numbers, raised symbols or pictograms, and Grade II Braille at accessible height locations.
 - (2) Proportions, height, finish, contrast, and locations according to accessibility requirements.
 - d. Determine building, room, and area numbering with University of Miami Florida Inventory of School Houses (UMISH) at least 30 days before initial submittal of drawings.
 - e. Room names at signage of any classroom or laboratory shall be limited to classrooms or laboratories unless otherwise requested by the UMBS Committee. Remaining spaces shall have names at signage according to UMBS Committee signage standard's requirements.
 - f. Provide directional signage at inaccessible entrances indicating the route to accessible entrances.
 - g. Provide directional signage at entrances of the inaccessible toilet and bathing facilities indicating the route to the accessible entrances of the accessible toilet and bathing facilities.

- h. Background Colors:
- (1) Provide the following signage with a black background at the following locations and where required by code:
 - (a) At the primary entrances, identifying signage shall contain room names, numbers, and Braille. Provide room numbers and Braille only at secondary or exit doors of these spaces.
 - (b) At each toilet room entry. Identifying signage shall contain toilet room symbols with verbal text and Braille.
 - (c) Accessible egress signs.
 - (d) At corridors, directional signs shall indicate directions to specific room numbers or subject areas. Provide one directional sign for every 5,000 square feet of project.
 - (2) Provide red background signage at the following locations and where required by code:
 - (a) "FIRE EXTINGUISHER INSIDE" at the main entry door of a room containing a fire extinguisher.
 - (b) "FIRE ALARM PULL STATION INSIDE" at the main entry door of a room containing a pull station.
 - (c) "EMERGENCY EGRESS - KEEP AREA CLEAR" at emergency egress openings and not readily identifiable secondary egress doors.
 - (d) "EMERGENCY RESCUE - KEEP AREA CLEAR" at emergency rescue openings.
 - (e) "ELEVATOR EMERGENCY" at the elevator emergency alarm bell.
 - (f) Emergency exit routes at appropriate locations.
 - (g) "IN CASE OF FIRE DO NOT USE ELEVATOR. USE STAIRWAYS" at elevator call stations.
 - (h) "STORAGE NOT PERMITTED" at mechanical, electrical, and kiln rooms.
 - (i) At classrooms with a maximum capacity of instructional or assembly spaces housing more than 50 students. Locate in the space next to the main entry door.
 - (j) Raised image signage shall be on a beveled or square edge laminated plastic panel with a thickness of at least 1/8". Tape applied or glued raised text, Braille, or symbols are not allowed.
 - (k) Attach signage with tamperproof screws, shields, and double stick tape or adhesives at mounting heights of 42 or 60 inches above finish floor to sign centerline at locations according to accessibility requirements.
9. Evacuation Signage
- a. According to FBC requirements, provide a floor plan with related graphics and text, for contractor's installation, showing the primary and secondary evacuation routes from each space with an occupant load of 6 or more and not having a door

- opening directly to the exterior.
 - b. The routes of evacuation shall be indicated in contrasting colors and only indicate the evacuation route from the applicable space.
 - c. Orient the map so when facing the mounting wall adjacent to the room exit, the "YOU ARE HERE" arrow will point up.
 - d. Text and numbers shall read from left to right.
 - e. Provide a metal frame with appropriate safety glazing.
10. Traffic Signage
- a. Provide galvanized steel signage for traffic control, accessible parking spaces, and accessible passenger loading zones.
 - b. Aluminum components are not allowed.
 - c. Locate signage away from traffic lanes to be clear of passing buses and cars.
11. Obstruction Warnings:
- a. Comply with all FBC required life safety potential hazards.
 - b. Provide padding with colored striping for TV brackets below 6'8":
 - (1) Apply padding to exposed lower edges and corners of bracket with screws at 6 inches on center and double stick tape.
12. Safety Zone Lines:
- a. Lines defining safety zones around machinery accessible to students shall be painted on the floor surrounding each piece of equipment.
 - b. Provide a continuous 2 inch wide yellow line, according to the following:
 - (1) 36 inches from the machinery to any side needed for operation or access.
 - (2) 12 inches when machines are back to back, along a wall, or in other special positions.
13. Construction documents shall show the locations, types, sizes, and quantity of Identifying devices.

MEDICAL CAMPUS

Refer to University of Miami Visual Identity Manual

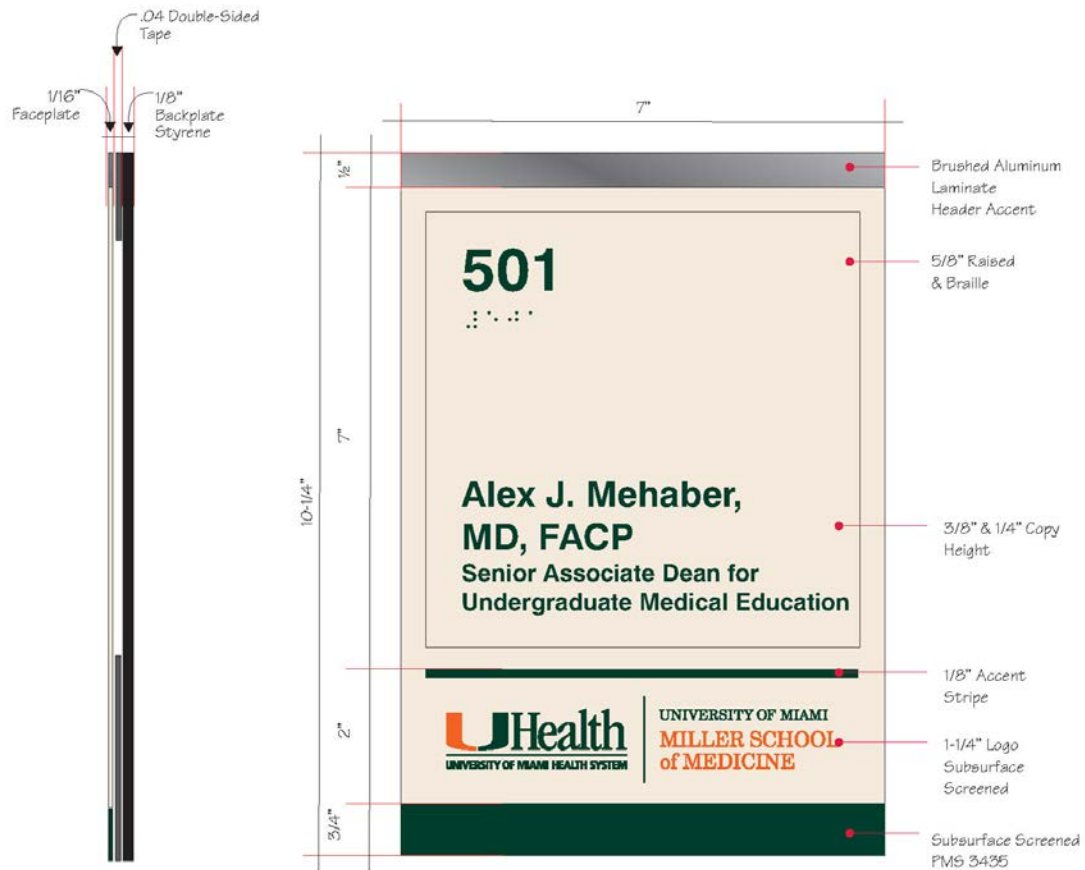

Custom ID Frame & Insert

- 10-1/4" X 7"
- 4.0 Module w. Oversize Backplate
- Square No Perimeter
- 1/2" Brushed Aluminum Header Accent
- 3/4" Subsurface Screened Logo & Accent Stripe
- Digital Insert
- Subsurface Screened Logo & Accent Stripe

MEDICAL CAMPUS

Refer to University of Miami Visual Identity Manual

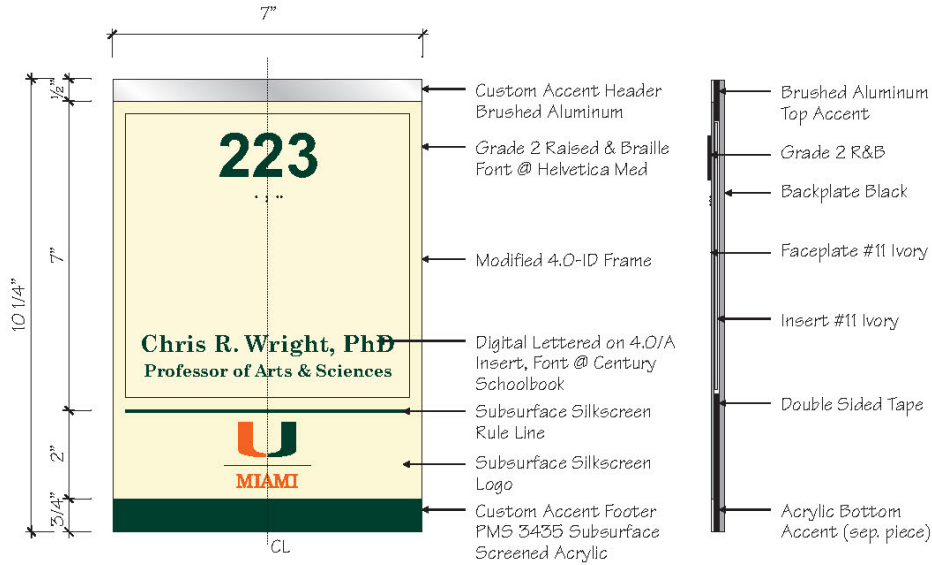

Identification – Room ID

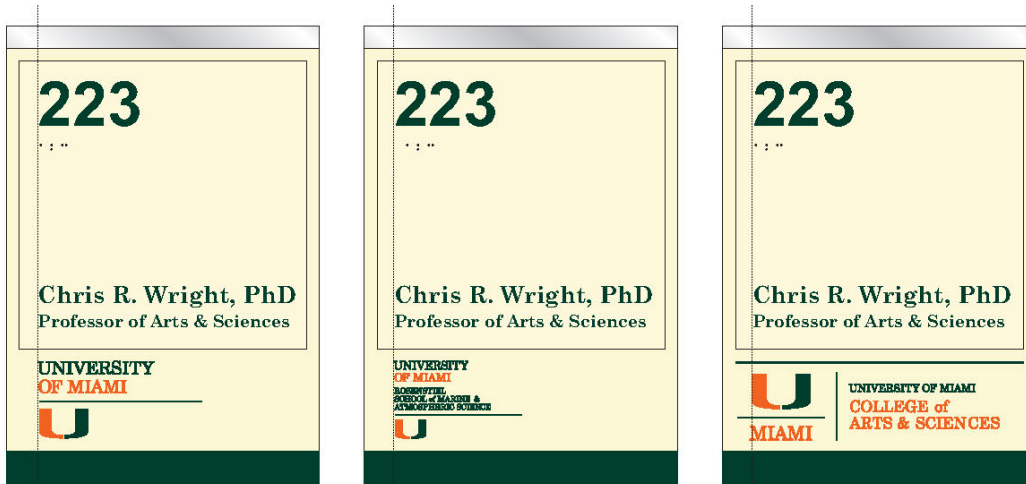

Alternates

CORAL GABLES CAMPUS

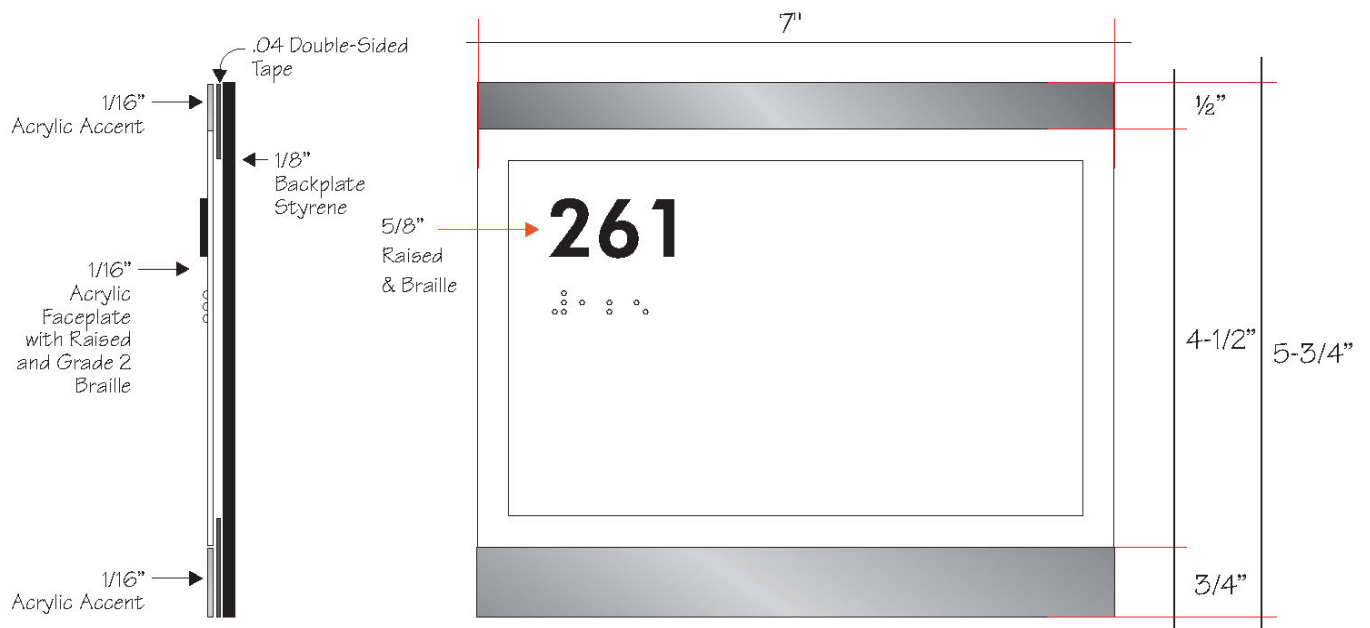

Module ID with Oversized Backplate

- 5-3/4" X 7" Oversize Backplate with Accent Top & Bottom (Overall)
- 4-1/2" X 7" = Module
- Square Without Perimeter

CORAL GABLES CAMPUS
Interior Signage

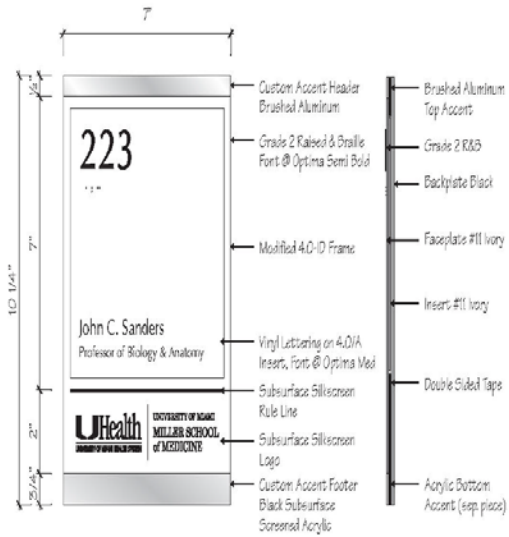

Front of House

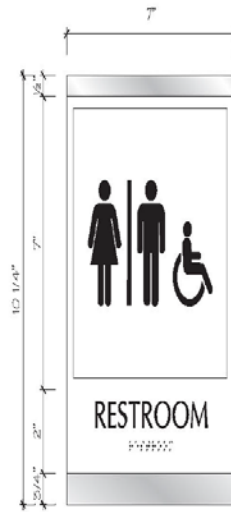

Alternate Layout



General Room ID

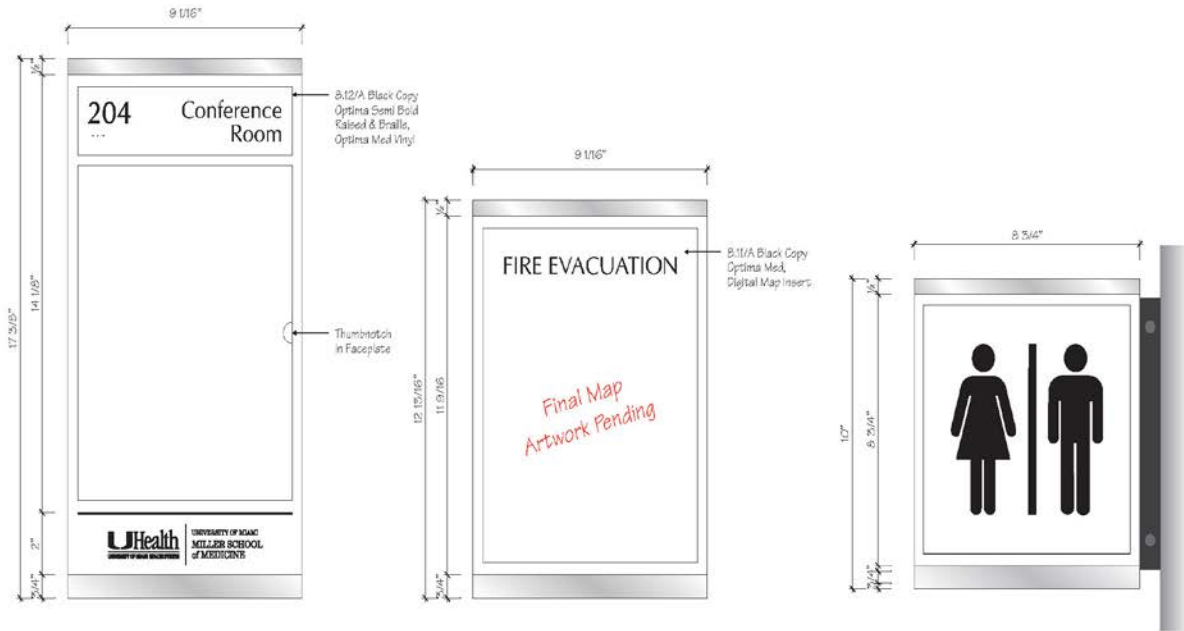

Conference Room
Paper Holder

FE Map/ Paper Holder

Restroom Wayfinding ID

CORAL GABLES CAMPUS
Interior Signage

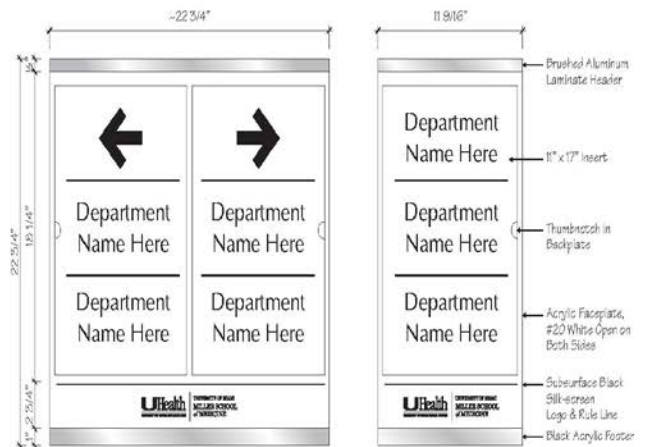
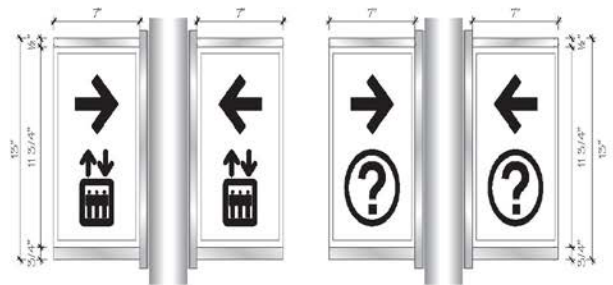
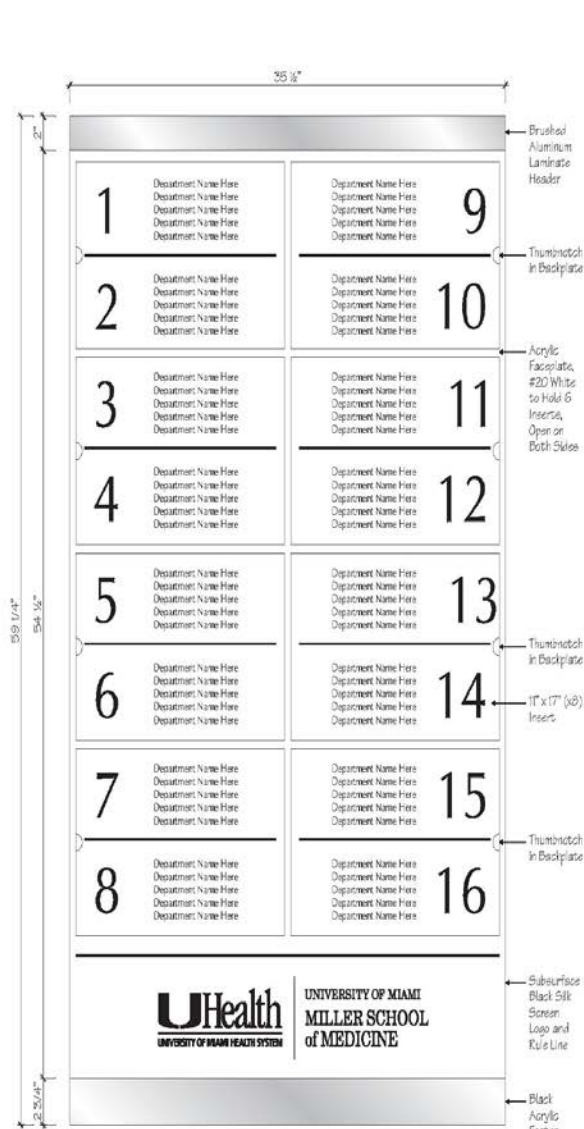

CORAL GABLES CAMPUS
Interior Signage



10 17 00 Telephone Specialties

Verify UM requirements.

10 21 13 Toilet Compartments

1. All toilet compartments, accessory items, colors, finish, applications and details are to be

reviewed and approved by the UMBS Committee prior to final development of the construction documents.

2. All locations and dimensions are to be field verified prior to installation.
3. All toilet compartment items and accessories shall comply with the following:
 - a. Americans with Disabilities Act and Accessibility Guidelines (ADA)
 - b. American with Disabilities ACT (ACT) Accessibility Guide Lines for Building and Facilities; Architectural Barriers (ABA) Accessibility.
 - c. American Disabilities Act of Accessibility Guidelines (ADAAG).
 - d. Florida Department of Community Affairs - Florida Accessibility Code for Building Construction (DCA).
 - e. National Fire Protection Code (NFPA).
 - f. All other applicable codes.
4. At group toilet rooms, provide toilet partitions at each toilet and urinal screens at each urinal. Provide privacy screens at showers according to program requirements. All toilet compartments shall have an ASTM E 84 Class II flame spread rating Index (26-75) and Smoked Developed < 450 to achieve a Class "B" Fire Rating.
5. Toilet partitions, privacy screens, and urinal screens shall be solid plastic, with non-corrosive panels, doors, pilasters, and accessories of polymer resins, providing a waterproof, non-absorbent, self-lubricating surface resistant to marking with pens, pencils, or other writing instruments.
6. Panels shall have a 1 inch minimum thickness.
 - a. Color shall be uniform throughout.
 - b. Edges shall be machined to a 1/4" radius with sharp corners removed.
7. Toilet partitions, privacy screens, and urinal screens shall have floor mounted pilasters and overhead bracing, with full length wall brackets. Other types of mounting conditions may be accepted on a per condition basis.
 - a. Wall brackets shall be continuous solid plastic when available from the manufacturer.
 - (1) Stainless steel wall bracket alternate may be accepted by on a per condition basis.
 - (2) Wall brackets shall be continuous and extend the full length of the panel and through-bolted at panel and pilasters.
 - b. Overhead bracing shall have a metal anti-grip design.
8. Pilaster shoes shall be solid plastic when available from the manufacturer.
 - a. Stainless steel pilaster shoe alternate may be accepted on a per condition basis.

- b. Shoes shall be fastened to floor with at least 2 connectors and 2 through-bolts at pilasters.
9. Top edges of compartment panels and doors shall be at least 70 inches above finish floor and mounted not more than 12 inches above finish floor. Pilasters shall be 82 inches high minimum.
10. Door hardware, anchorages, and accessories shall be manufacturer's heavy-duty series.
- a. Doors shall be self-closing.
 - b. Hinges shall be continuous stainless steel, mounted at doors and pilasters with fasteners as specified at 8 inches on center. Gravity/cam or integral hinges are not allowed.
 - c. Doors shall be furnished complete with necessary wall bumpers, door pulls, 6 inch heavy-duty door strikes, keepers, and latch housings.
 - d. Provide accessible door pulls and doorstops as required.
 - e. Verify accessibility requirements for door widths and stall sizes.
 - f. Fasteners shall be stainless steel, tamperproof one-way sex bolts, or anti-theft torx screws throughout installation. Wall connections shall be plastic anchors, lead anchors, or toggle bolts as required by field conditions.

10 21 16 Shower and Dressing Compartments

1. All shower and dressing compartment accessory items, colors, finish, applications and details are to be reviewed and approved by the UMBS Committee prior to final development of the construction documents.
2. Modular shower units shall be solid HDPE panel material, not less than 1" thick, seamless with eased edges and with homogenous color and pattern throughout thickness of material. Unit shall contain a shower compartment and matching dressing compartment using floor and ceiling anchors. Unit shall contain heat sink strip at exposed bottom edges.
3. Shower receptor shall be manufactured from terrazzo.
4. All shower and dressing room compartments shall have an ASTM E 84 Class III flame spread rating Index 25.

10 21 23 Cubicles

1. All cubicle curtains, track, products accessory items, colors, finish, applications and details are to be reviewed and approved by the UMBS Committee prior to final development of the construction documents.

10 22 13 Wire Mesh Doors and Partitions

1. Wire type used is to be constructed of 10 gage steel wire woven into 1-1/2" diamond mesh, fastened to doorframes.
2. Provide swing doors with cylindrical mortise locks.
3. Door and partition components shall be constructed of cold rolled channels.

10 22 19 Demountable Partitions

1. Provide site assembled demountable partitions, 1-hour fire rated assembly with a minimum STC 35 rating. Manufactured face panel of gypsum factory primed for field painting with a fabric facing.
2. Doors and frames, when required, shall have a 1-3/4" solid core wood with a minimum 20 minute fire rating.
3. All cubicle curtains, track, products accessory items, colors, finish, applications and details are to be reviewed and approved by the UMBS Committee prior to final development of the construction documents.

10 22 39 Folding Panel Partitions

1. At auditoriums, provide enclosures to secure panels when not in use. Means of egress widths shall not be reduced.
2. At classrooms, provide maximum opening widths with panels stacked parallel or perpendicular to overhead tracks and with enclosures to secure panels when not in use.
3. Panel Types:
 - a. Single Panels:
 - (1) Use single or multiple wall configurations of any height with manual operation and side or remote stacking.

- (2) Provide automatic indexing or stacking with switching curve for panels over 2 feet high.
 - (3) Use multi-directional carriers for panels less than 12 feet high or 4-wheeled trolleys for taller applications.
 - b. Hinged Paired Panels:
 - (1) Use at straight runs of heights less than 18 feet with manual operation and center stacking.
 - (2) Provide 4-wheeled trolleys.
 - c. Continuously Hinged Panels:
 - (1) Use with one-way or bi-parting electric operation and center stacking.
 - (2) Provide 4-wheeled trolleys.
- 4. Construction:
 - a. Operable partitions shall be steel panel and welded frame construction.
 - b. Particleboard construction is not allowed.
 - c. Panels finishes shall be one of the following:
 - (1) High-pressure decorative laminate without splices or joints. Edges shall be straight and sealed.
 - (2) Vinyl.
 - d. Panel face shall not exceed a 25 flame spread rating.
 - e. Provide partition STC rating of not less than 55 at auditoriums and 48 at other spaces.
 - f. Provide interlocking vinyl sound seals between panels and drop seals between panels and floor.
 - g. Above ceiling tracks, provide an acoustical barrier having a sound transmission loss equal to or greater than the operable partition when including the ceiling.
 - h. Provide manual operation for partitions (except as stated above).
 - i. Operable partitions shall be suspended from an overhead track and without a floor track or guides.
 - j. Egress Doors:
 - (1) Provide egress doors within operable panels when required by code or program.
 - (2) At auditoriums, do not provide egress doors within operable panels, use alternate means of egress when required by code.
 - k. Do not locate instructional boards on operable partitions unless no other fixed wall is suitable for viewing or meeting instructional board square footage minimums.

10 26 00 Wall and Door Protection

1. Provide handrail to resist a uniform load of 50 lb/ft and a concentrated load of 200 lb/ft not applied concurrently.
2. Provide a five year guarantee on workmanship and materials.
3. Wall guards shall be high impact vinyl and stainless steel with UMBS Committee approval; 3/16" or heavier gage, PVC or aluminum if necessary to prevent warping.

10 28 00 Toilet Room Accessories

1. Toilet accessory components, mounting heights, and locations shall comply with applicable accessibility codes.
2. Paper towel dispensers shall be stainless steel finish and able to dispense the standard of single fold towels. Four inch deep dispensers cannot be used with the standard towels. Provide at individual lavatories and classroom sinks. Provide one for every two lavatories or fraction thereof in group toilet rooms. Do not provide paper towel dispenser at laboratory sinks.
3. Provide a double toilet paper holder at each water closet and at the highest accessible height and location.
4. Paper towel waste receptacles are not-in-contract.
5. Provide, near the water closet, a sanitary napkin receptacle at female staff and student female use individual toilets and at each female group toilet room stall.
6. Provide stainless steel grab bars with preened surfaces and flanges for exposed mounting at accessible toilets.
 - a. Grab bars and the installation of grab bars shall comply with applicable accessibility codes.
 - b. Provide vandal resistant fasteners and backing in partition or wall for sufficient anchoring to resist a 250 pound force applied from any direction.
7. Mirrors
 - a. Mirrors in faculty and staff toilet rooms shall be 1/4" tempered glass, electrolytic alloy copper-plated, and in stainless steel frames with concealed theft-proof mountings.
 - b. Mirrors in public and student toilet rooms shall be polished stainless steel surfaces with 1/4" minimum reinforced pressed board backing and stainless steel frames or wraparound edges. Provide concealed theft proof mountings, proper anchoring, and wall backing according to manufacturer's requirements.
 - c. Mirrors in public and group student toilet rooms shall not be installed above

- lavatories.
 - d. Mirrors in individual toilet rooms are not required to be over lavatories.
 - e. Provide non-tilting fixed mirrors at appropriate heights and sizes to comply with accessibility requirements.
8. Provide a wall mounted vandal resistant stainless steel soap dispenser over each lavatory classroom and academic hall sink according to program requirements.
- a. Use deck mounted soap dispensers to comply with accessibility requirements.
 - b. At locations with multiple lavatories or at group showers, use a centralized gravity soap system when cost effective.
 - c. No soap dispensers shall be provided in residence halls.
9. Hot air hand dryers
- a. Hot air hand dryers shall be installed in all new / renovated public areas in the resident halls and in all Academic and Administrative buildings.
10. Sanitary napkins
- a. All women's toilet toilets in public areas, resident halls and in all academic / administrative buildings shall have sanitary product dispensing machines (napkin and tampon).
 - b. All women's toilet toilets in public areas, resident halls and in all academic / administrative buildings shall have sanitary napkins receptacles as part of each stall.
11. Provide rod and heavy duty white vinyl shower curtains with exposed fasteners in showers.
12. Provide heavy duty, chrome plated, robe hooks in shower and dressing areas.

10 43 00 Emergency Aid Specialties

Provide AED as per State of Florida Legislation requirements.

10 44 13 Fire Protection Cabinets

All portable fire extinguisher and non-valve cabinets shall be furnished and installed to meet National Fire Protection association (NFPA) Pamphlet 10, latest edition, Florida Department of Community Affairs-Florida Accessibility Code for Building Construction (DCA), American with Disabilities ACT (ACT), Accessibility Guide Lines for Building and Facilities, and Architectural Barriers (ABA) Accessibility and American Disabilities Act of Accessibility Guidelines (ADAAG).

- 1. Each extinguisher shall be approved by Underwriter's laboratory (UL) and bear their label.

2. Fire extinguisher cabinets shall be lockable with full Lexan door, non-breakable glass, pressure handle and semi recessed.
3. An acceptable means of identifying fire extinguisher location must be done by an arrow type sign. Refer to appendix "A", a-1-6.5 of NFPA pamphlet 10.
4. Cabinets shall be clear aluminum, flanged, recessed (similar to fire hose cabinets), lockable and comparable to the preferred Duo Panel style of cabinet.
5. Refer to NFPA pamphlet 10, Chapter 2, 3 and 4. Chapter 2 is used to determine the classification of potential fires and the rating or relative fire extinguishing effectiveness of various type of extinguisher. Chapter 3 assists in the selection of extinguisher which is dependent upon the character of anticipated fires, property construction and occupancy, the vehicle or hazard to be protected, ambient temperature conditions and other factors. The maintenance of extinguishers is determined by Chapter 4.
6. Penetrations of walls by cabinets or other penetrations is required in order to provide a recessed cabinet as required, unless openings and void are sealed with fireproof materials, are prohibited. Fire rated walls must have the rating by penetrations or reduction of thickness.

10 44 16 Fire Extinguisher

1. Comply with applicable codes for quantity and location of fire extinguishers.
2. Locate fire extinguishers in instructional spaces and other staff controlled rooms near primary entrances and at ADA accessible heights. Provide required signage at room entrance.
 - a. At instructional spaces and low hazard areas, use fire extinguisher cabinets with tempered glass panel doors. Cabinets shall be either semi-recessed with rolled corners or fully recessed.
 - b. At staff spaces and other remaining spaces, use wall brackets with straps.
 - c. Extinguisher cabinets in fire rated walls shall be fire rated.
 - d. Extinguishers and cabinets shall be visible from the main entry door and not hidden from view behind wall construction, furniture, or built-ins.
3. Areas requiring fire extinguishers:
 - a. Flammable areas (sodium bicarbonate 40BC):
 - (1) Kitchens (Install alkaline dry chemical, for saponification of greases, within 15 feet of cooking equipment).
 - (2) Science laboratories
 - (3) Automotive shops
 - (4) Boiler rooms
 - (5) Air handling unit rooms
 - (6) Flammable liquid storage areas

- (7) Duplicating stations
 - (8) Home economics classrooms
 - (9) Teacher lounges
 - b. Hazardous areas (4A - 60BC):
 - (1) Woodworking shops
 - (2) Storage rooms where wood or paper products are stored
 - (3) Electrical rooms
 - (4) Portables
 - c. Low hazard areas (2A - 10BC):
 - (1) Corridors and remaining rooms
 - (2) Class A or B fire areas
 - d. Electronic lab areas (carbon dioxide, Class C, 10BC)
- 4. See NFPA for fire blanket requirements

10 51 13 Metal Lockers

- 1. Types and numbers of metal lockers are to be located and specified according to program requirements.

10 55 00.13 USPS – Delivery Postal Specialties

- 1. For Postal Service (USPS) deliveries, provide a USPS approved drop box for a new facility delivery and collection with an embedded base anchorage and with components, installation, and location complying with USPS requirements as per USPS P-1118F.

10 55 00.16 Private – Delivery Postal Specialties

- 1. Provide mailroom or mail area locations in administration areas containing open sorting mail modules at least 6 inches high, 12 inches wide and 15 inches deep. Provide quantity according to program requirements. Bottom of highest module shall not exceed 6'0" above finish floor.

10 56 13 Metal Storage Shelving

- 1. Metal shelving shall be clip-type adjustable shelving of modular unit construction on individual bolted frame assemblies. Sections shall be reloadable and each shelf independently adjustable without the use of tools.
- 2. Shelving Unit Sizes.

- a. Type A: 85 inches high, 36 inches wide, 12 inches deep, with fixed top shelf, six adjustable shelves, and closed base fronts.
 - b. Type B: 85 inches high, 36 inches wide, 18 inches deep, with fixed top shelf, six adjustable shelves, and closed base fronts.
 - c. Type C: 85 inches high, 36 inches wide, 24 inches deep, with fixed top shelf, six adjustable shelves, and closed base fronts.
3. Attach shelving units securely to walls with proper backing, or if freestanding, to floors. Wall standards with adjustable brackets are only allowed at custodial closets.

10 56 26 Mobile Storage Shelving

1. Provide all steel construction mobile storage shelving. Shelving shall be manually operated with a surface mounted carriage 36" wide x 66" high with 12" shelf depth with flat six shelves that are plumb and level to manufacturer's tolerance with full height carriage end panels.
2. Provide anti-tipping features. The manual operating system shall operate with a 1 lbf requirement to move 1,000 lbs.
3. Provide manufacturer's five (5) year material and workmanship warranty.

10 73 13 Awnings

1. Provide fixed awnings with welded steel or aluminum frames meeting the following criteria.
 - a. AWS D1.1/D1.1M, "Structural Welding Code - Steel."
 - b. AWS D1.2/D1.2M, "Structural Welding Code - Aluminum."
2. Frame corners and seams are to be welded continuously, complying with AWS recommendations. Grind and brush all welds. Brazed welds are not acceptable.
 - a. Awnings are to be shop assembled to the greatest extent possible.
3. Awning Fabric shall be treated to achieve a flame resistance rating which complies with NFPA 701.
 - a. Fabric is to be a woven, non-shrinking fabric, made of 100% modacrylic solutions dyed fibers with a fluorocarbon finish.
 - 1) Typical weight: approximately 9.25 oz. per square yard.
 - 2) Flame Spread: 10
 - 3) Smoke Density: 25
 - 4) Mildew Resistance: as per ASTM G21
 - b. All seams are to be heat sealed. Where this is not possible, the seams are to be sewn.

4. Both frame and fabric shall have an 8 year warranty from date of substantial completion.
5. Frames shall be powder coated with colors chosen from the manufacturer's standard color chart.
6. All awning accessory items, colors, finish, applications and details are to be reviewed and approved by the UMBS Committee prior to final development of the construction documents.
7. Fabricator should have a minimum of 10 years' experience in similar work.
8. Shop drawing submittals are to include:
 - a. Drawings for all components and application conditions of awnings which are not fully dimensioned or detailed in the product data.
 - b. Co-ordination with adjoining work.
 - c. Sections and details at all connections and corners.
 - d. A schedule of all units to be furnished, including field dimensions at each location.
9. All locations and dimensions are to be field verified prior to installation.

10 75 16 Ground Set Flagpoles

1. Coordinate flagpole location with the UMBS Committee and comply with the following:
 - a. Exposed height shall be 30 feet plus depth required for embedded foundation with ground sleeve.
2. Flagpole design shall withstand wind velocity pressures determined by American Society of Civil Engineers (ASCE) 7-98.
3. Provide a tapered, seamless fiberglass pole with an internal halyard system. Use of a tapered, seamless aluminum pole and external halyards may be accepted at a secure location.
4. A 6-inch diameter aluminum finial ball with mill finish is the only accepted ornament.
5. Provide a flash collar to match pole finish.

10 83 16 Banners

1. Provide a banner that meets the following structural performance Design, fabricate, and install banners to withstand loads from gravity, wind and structural movement, including thermally induced movement, according ASCE 7 and to resist, without failure, other conditions of in-service use and including weather.
2. All banner accessory items, colors, finish, applications and details are to be reviewed and approved by the UMBS Committee prior to final development of the construction documents.
 - a. Shop drawings for banners shall show materials, fabrication, dimensions, mounting heights, clearances, and installation details. Show colors and graphic layout and content. Show text message, font, character sizes, and other graphic forms; character spacing, word spacing, and line spacing; margin widths; position of copy; and other information related to graphic design. Retain subparagraph below for large banners and displays of multiple banners.
3. All banner components should be clear anodized or stainless steel.
4. Show locations for blocking, reinforcement, and supplementary structural support to be provided by others.
5. The UMBS Committee considers the use of banners as delegated systems when used in conjunction to construction and as such should be reviewed and approved prior to use.

DIVISION 11 - EQUIPMENT

This chapter identifies criteria for the selection and design of equipment components with the purpose of establishing minimum standards, acceptable to UM, to be used as the basis of design for UM Coral Gables campus buildings.

- 11.1 General Requirements.
 - 11.1.1 Submittals
 - 11.1.2 Workmanship Requirements
- 11.2 Codes
- 11.3 Standards
- 11.4 Design Criteria
- 11.5 Specific Requirements (Organized by CSI Master Format 2012 Number and Titles)

11.1 General Requirements

Before the start of construction on new buildings and/or major renovations, the Contractor shall provide a drawing for each building floor level showing the coordination of all structural, architectural and MEP items. This includes, but is not limited to: Structural members, floor plates, architectural ceilings, soffits, smoke barriers, fire walls, vertical shafts, sleeves, fire dampers, HVAC ductwork and equipment, plumbing piping and equipment, fire protection piping and equipment, alarm systems, communications, electrical distribution and equipment, lighting, controls, BMS, lighting protection, security systems, etc.

The design, use and implementation of equipment shall provide in a manner to foster an efficient environment for the users and should be considered with the following objectives:

1. Cost
2. Life cycle
3. Longevity
4. Maintenance
5. Warranty
6. Occupant Safety

Quality of the information, materials, shop drawings, reviews, equipment integrity, completeness and installation shall be a major concern of the A/E, as University of Miami. All specialty components are intended for long term usage for the general public designed with specific emphasis for the occupants, disabled and custodial use.

11.1.1 Submittals

Submittal shall include product data, Submittals, Shop drawings, samples and closeout submittals as defined in applicable specification sections.

11.1.2 Workmanship Requirements

Refer to specific requirements included herein.

11.2 Codes

1. Florida Building Code (FBC).
2. Florida Department of Community Affairs-Florida Accessibility Code for Building Construction (DCA).
3. American with Disabilities ACT (ACT) Accessibility Guide Lines for Building and Facilities; Architectural Barriers (ABA) Accessibility.
4. American Disabilities Act of Accessibility Guidelines (ADAAG).
5. American Society of Civil Engineers (ASCE 7).
6. National Electric Code (NEC)
7. National Fire Protection Code (NFPA)
8. Underwriters Laboratory (UL)
9. City of Coral Gables, Local Codes and Ordinances.

11.3 Standards

1. University of Miami special requirements and experience with various manufacturers, products and installations have led to adopted procedures and practices incorporated into these standards.
2. Specific product manufacturer requirements.

11.4 Design Criteria

Refer to specific requirements under each section included herein.

11.5 Specific Requirements (Organized by CSI Master Format® 2012 Numbers & Titles)

11 05 13	Common Motor Requirements for Equipment
11 12 00	Parking Control Equipment
11 13 00	Loading Dock Equipment
11 31 00	Residential Appliances
11 40 00	Food Service Equipment
11 51 23	Library Stack System
11 52 13	Projection Screens
11 53 13	Laboratory Fume Hoods
11 61 43	Stage Curtains
11 66 23	Gymnasium Equipment
11 66 53	Gymnasium Dividers
11 82 26	Facility Waste Compactors

11 05 13 Common Motor Requirements for Equipment

1. All features of common motors for equipment of motors, installed units, and accessory devices and features shall be compatible with the following:
 - a. Motor controllers.
 - b. Torque, speed and horse power requirements of the load.
 - c. Ratings and characteristic of supply circuit and required control sequence.
 - d. Ambient and environmental conditions of the installation location comply with manufacturer requirements.
 - e. NEMA MG 1 unless otherwise indicated by the A/E.
 - f. IEEE 841 for severe-duty motors.
2. Provide the following motor characteristics for common motor requirements provided to the UMBS Committee:
 - a. Duty: Continuous duty at ambient temperature of 40 deg. C and at 3300 feet above sea level criteria.
 - b. Capacity and torque characteristics should be sufficient to start, accelerate, and operate connected loads at the designated speeds, at installed altitude and environment with the designated operating sequence, and without exceeding nameplate rating or considered service factors.
3. The following common motors criteria will be are permitted to be used at UM:
 - a. PolyPhase Motors having the following requirements:
 - 1) Description NEMA MG 1, Design B, medium induction motor.
 - 2) Efficiency: Energy efficient, as defined in NEMA MG 1.
 - 3) Service factor; 1.15.
 - b. Multispeed Motors: Variable Torque:
 - 1) For motors with 2:1 speed ratio, consequent pole, single winding.
 - 2) For motors with other than 2:1 speed ratio, separate winding for each speed.
 - c. Multispeed Motors: separate winding for each speed.
 - d. Rotor: random-wound, squirrel cage.
 - e. Bearing: regreasable, shielded, antifriction ball bearing suitable for radial and thrust loading.
 - f. Temperature rise: Match insulation rating.
 - g. Insulation: Class "F", unless indicated otherwise by manufacturer.
 - h. Enclosure Materials: cast iron for motor frame sizes.
4. PolyPhase Motors with Additional Requirements:
 - a. Motors used with reduced-voltage and multispeed controllers shall have match wiring connection requirements for controller with required motor leads. Provide terminals in motor control box, suited to control method.
 - b. Motors used with variable frequency controllers as per manufacturer's recommendations shall have the following:
 - 1) Windings: Copper magnet wire and moisture-resistant insulation varnish designed and tested to resistant spikes, high frequencies, and short time rise pulses produced by pulse width modulated inverters.

- 2) Energy and premium-efficient motors: Class B temperature rise; Class F insulation.
 - 3) Inverter duty motors: Class F temperature rise; Class H insulation.
 - 4) Thermal protection: Comply with NEMA MG 1 requirements for thermally protected motors.
 - 5) Severe duty motors: Comply with IEEE 841, with 1.115 minimum service factors.
5. Single Phase Motors
- a. Motors larger than 1/20 hp shall be one of the following, to suit starting torque and requirement of the specific motor application:
 - 1) Permanent-split capacitors.
 - 2) Split phase.
 - 3) Capacitor start, inductor run.
 - 4) Capacitor start, capacitor run.
 - b. Multispeed Motor: Variable torque, permanent-split capacitor type.
 - c. Bearings: pre-lubricated, anti-friction ball bearings or sleeve bearings suitable for radial and thrust loading.
 - d. Motors: 1/20 HP and smaller: shaded-pole type
 - e. Thermal Protection: Internal protection to automatically open power supply circuit to motor when winding temperature exceeds a safe value calibrated to temperature rating of motor insulation. Thermal protection device shall automatically reset when motor temperature returns to normal range.

11 12 00 Parking Control Equipment

- 1. UM shall use the following parking control systems and products for transient, merchant validated, limited date and time and valet parking.
- 2. Products used shall have an automatic, communicating, aluminum barrier gate with a straight gate arm and ½ HP operators. The system shall be connected to a vehicle detector, recessed and active infrared vehicle presence detectors or card reader as determined and approved by the UMBS Committee.
- 3. Exit terminals shall be activated by either vehicle detector or card reader as determined and approved by the UMBS Committee.
- 4. If Pat stations are used, they shall have stand-alone operation, using fee computers that are a nodular and PC based system, for fee computer terminals and a barcode ticket reader and printer.
- 5. Parking management software shall be capable of collecting data for revenue and activity reporting for access and space control, tracking tickets, and programming parking controls equipment.
- 6. Access Control units:

- a. Card reader Controlled Unit shall be a programmable, multiple code system; using a magnetic strip card and a standalone operation that is pedestal mounted.
7. Provide manufacturer technical and upgrade service for equipment and software for two (2) years.

11 13 00 Loading Dock Equipment

1. For each type of product indicated, provide construction details, material descriptions, dimensions of individual components and profiles, and finishes for loading dock equipment. Include rating capacities, operating characteristics, electrical characteristics, and furnished specialties and accessories.
2. Provide for the UMBS Committee's review an evaluation of comprehensive tests performed by manufacturer and witnessed by a qualified testing agency. Indicate compliance of dock levelers with requirements in MH 30.1 for determining rated capacity, which is based on comprehensive testing within last two years of current products.
3. All loading docks are to be provided with scissor lifts to accommodate a variety of campus and other non-standard bed height delivery vehicles.
4. Scissor lifts should be flush with the ground when lowered and raised to a height of approximately 4'-0" at the dock to accommodate trucks. Provide a small concrete curb in the recess in the pavement or base to reduce debris accumulation under the lift.
5. Buildings with greater delivery demands as determined by the UMBS Committee shall be provided with two bays, as well as a man door, which includes a laminated glass vision panel and is secured with an access control device. Single bay designs should also provide a man door for personnel access.
6. When a loading dock is required, a large and open interior space shall be required for staging delivered materials with support rooms around the perimeter for other needs.
7. Provide adequate turnaround area for standard delivery vehicles. If a water compactor is located at loading dock areas, refer to specific trash compactor manufacturers for clearance requirements for waste removal vehicles.
8. Provide a minimum of one (1) approximately signed service vehicle parking stall, adjacent to dock area.
9. Provide for communication between the delivery person and the building's receiving staff. This can be accomplished by telephone or intercom.
10. Provide a hose bib on the dock to facilitate wash down of the dock and adjacent waste exterior areas (for example where compactors and waste containers are located). A trench drain will provide a means to keep the area of ponding water.

11. Provide secured and protected storage area where biological and radioactive waste can be picked-up at the indicated location.
12. Provide a secure space for cylinder storage with required tie-backs, as needed.
13. Dock doors shall be at least 9'-0" wide and 12'-8" minimum on center when using multiple doors. It will be responsibility of the A/E to verify and consider the types of delivery vehicles and products being delivered in order to determine the appropriate door type.
14. Loading docks shall be at the same elevation as the finished floor of the building and shall be either 44" minimum to 46" inches maximum above the elevation of the adjacent pavement. Provide dock levelers at all loading docks.
15. Loading docks must not be located at or near fresh intakes for buildings.

11 31 00 Residential Appliances

1. Provide washing machines and clothes dryers in food service areas, locker rooms, and vocational instructional spaces according to program requirements and in the following areas:
 - a. In home economics, provide residential washers and electric dryers for student use.
 - b. In elementary and middle schools food service and locker rooms, provide residential washers and gas or electric dryers for staff use.
 - c. Provide stacking washers and dryers for use in PLCs.
 - d. In high school food service and locker rooms, provide fifty pound capacity commercial washers and gas dryers for staff use.
 - e. Food service washers and dryers shall be on a 4 inch high raised concrete platform matching the finish floor material and the minimum required equipment footprint.
2. Provide gas dryers when gas is available and economically feasible, except at home economics instructional spaces.
3. Dryers shall be vented to the exterior.
4. All residential appliances shall comply with Accessibility requirements outlined in the U.S. Architectural & Transportation Barriers Compliance Board's "Americans with Disabilities Act (ADA), Accessibility Guidelines for Buildings and Facilities (ADAAG)." And ANSI A117.1.
5. Energy Ratings: Provide appliances that qualify for the EPA/DOE ENERGY STAR product labeling program.
6. Provide the following appliances for residential dormitory community kitchens. As UM's products and vendors change occasionally verify appliances with the UMBS Committee's current requirements.
 - a. Refrigerator: General Electric side-by-side with ice and water dispenser in the door (GSS22QFMWW)
 - b. Wall Oven: General Electric JRP15WWWW
 - c. Cook top: General Electric JP34OWCWW

- d. Recirculation Fan: General Electric JN327XWH

11 40 00 Food Service Equipment

1. General.
 - a. For most facilities, the equipment is listed in the UMBS Committee's equipment standards. Additional equipment or different models other than the equipment listed may be required to accommodate special program requirements. Consult the UMBS Committee for additional information and requirements.
 - b. Use foam expanding agents and refrigerants that do not contribute to the depletion of the Earth's protective ozone layer. The use of products containing R-11, R-12, R-113, R-114, or R-115 is discouraged.
 - c. Equipment and installations are required to be listed by Underwriters Laboratories (UL).
 - d. Construction documents shall note the contractor to be responsible for the disconnecting and moving of equipment to designate UM storage facilities or as otherwise directed at kitchen renovations involving existing equipment removals.
 - e. Kitchen plumbing drawings shall be coordinated with food equipment and counter layouts.
 - f. Kitchen Floor Drains: See Division 15 for kitchen drainage requirements.
 - g. Use easily cleanable materials in food service areas. Components such as "Unistrut" or other similar materials are not allowed.
2. Trash Compacting System
 - a. Compactors will be used for dining room and facility waste instead of pulping and extractor equipment. Compactors are not-in-contract.
 - 1) In the dining room, locate compactor 2 feet away from a wall near the dining room exits and at least 3 feet away from the exits. If more than 1 unit in the dining room is provided, locate at remote exits.
 - a) Provide quarry tile under the compactor and extend 4 feet from the sides and front of the compactor and to the rear wall. Use a quarry tile or rubber base.
 - b) Walls around the unit shall be standard dining room wall finishes.
 - 2) If an additional compactor location is program required, locate in a staff secured space.
 - 3) Provide a convenient route, not through the kitchen, from the compactor to a service yard dumpster.
 - 4) See Division 16 - Power System Design for additional information.
 - b. See program requirements for compactor sizes and quantities.
3. Walk-in Cooler/Freezer
 - a. Insulated cold storage rooms shall be prefabricated, foamed-in place, free standing walk-in rooms, designed for easy, accurate, indoor on-site assembly over a recessed slab.
 - b. Refrigeration system components include a fully automatic outdoor air -cooled condensing unit and a ceiling mounted evaporator unit in the refrigerated room.
 - c. Prefabricated floor, ceiling, and wall sections shall contain at least 4 inches of insulation.

- d. Depress kitchen slab at walk-in cooler/freezer to provide equal cooler/freezer and finish kitchen floor elevations. Depth shall include thicknesses for floor insulation, quarry tile over a galvanized steel floor, and setting bed.
 - e. Stainless steel finish floor overlay panels shall be used only for renovation projects without a depressed slab.
 - f. Cold storage room floors shall be designed to carry 600 pounds per square foot loading and be finished with quarry tile.
 - g. Doors:
 - 1) The freezer door shall open into the cooler and the cooler door shall open into the kitchen.
 - 2) Provide vision panels in the cooler door and the freezer doors.
 - 3) Doors shall be self-closing.
 - h. Provide wet-trap floor drains for condensation.
 - i. Provide at least 8'-6" clear kitchen ceiling height for walk-in cooler/freezer rooms.
4. Custom Fabricated Food Service Equipment
- a. At food service areas, provide custom stainless steel fabricated equipment including, but not limited to the following, necessary accessories listed below:
 - 1) Cook's table with 1 compartment sink and overhead utensil rack.
 - 2) Baker's table with 1 compartment sink and overhead utensil rack.
 - 3) Vegetable/salad sink, 3 compartments.
 - 4) Pot washing sink, 3 compartments with overflow/scraping compartment.
 - 5) Worktables wired for electric with outlet.
 - 6) Pot racks, wall mounted.
 - 7) Serving counters/bays
5. Serving Line Equipment and Units
- a. Serving line aisle widths shall be at least 42 inches wide.
 - b. Stainless steel serving line equipment shall include:
 - 1) Milk box/Beverage Counter: Refrigerated according to program requirements. Provide floor drain near unit as needed/required.
 - 2) Top and Tray Slide: Counter top unit with 3 die formed inverted ridge tray slide.
 - 3) Hot Food Section: Dry, moist, electric, with 12 inch by 20 inch openings according to program requirements to fit standard cafeteria pans.
 - 4) Cold Food Section: Refrigerated frost top with a perimeter drain and refrigerated storage below with adjustable shelves.
 - 5) Protector Cases: Plexiglas front and ends installed over hot food section.
Display Cases: 18 inch wide unit with Plexiglas shelves and sneeze guards.
 - 7) Cashiers Stand: With footrest, cash drawer, and electrical and data connections routed to underside of cabinet base.
 - c. Interior/external serving bays shall include:
 - 1) A serving counter at least 9'-0" long with utility space for hot/cold equipment according to program requirements.
 - 2) Under counter electrical capability for mobile units and drop-in counter top equipment.
 - 3) Under counter shelving.

- 4) Point-of-sale (POS) station with electrical and data connections routed to underside of cabinet base.
 - 5) Roll-thru refrigerated and heated units.
 - d. Fronts, soffits, and walls of serving lines shall be designed with decorative themed colors and tile. If tile is not used on fronts and sides, edges must be finished with stainless steel angles.
6. Food Preparation, Holding and Dispensing Equipment
 - a. Food preparation equipment includes, but is not limited to:
 - 1) Floor mounted 60 quart mixer with a power bowl lift, bowl and beater accessories. (See the UMBS Committee for specific requirements)
 - 2) Ice Maker Daily Production Capacities:
 - a) Facility shall have a capacity of: 1,000 lbs.
 - 3) Mobile Can Storage and Dispenser Racks.
 - 4) Stationary Can Storage and Dispenser Racks.
 - 5) Inclined Can Rack
7. Cooking Equipment
 - a. Cooking equipment for food service shall include, but not limited to the following:
 - 1) Double stacked convection ovens with porcelain steel liners, stainless steel doors with glass panels and stainless steel front, left side, right side, top and back panels.
 - 2) Convection steamer with filtration equipment at boiler.
 - 3) Steam Kettle: Stainless steel unit, gas fired, complete with hot and cold water and filter system.
 - 4) Tilting/braising pan located according to program requirements.
 - 5) Hoodless fryer located according to program requirements.
 - 6) Deep fry combination with fryer drain cabinet and built-in filter system.
 - 7) Electric heavy-duty 2 burner range with polished stainless steel cabinet base, 6 inch stainless steel legs and adjustable bullet feet.
 - 8) Roll-thru refrigerated units.
 - 9) Roll-thru heated unit
 - b. Cooking equipment for Instructional Food Lab Commercial Cooking Center:
 - 1) Convection Oven: Stainless steel.
 - 2) Deep fat fryer with adjustable legs.
 - 3) Griddle with adjustable legs for mounting.
 - 4) Convection Steam Cooker with in-line water conditioner and legs for mounting.
8. Food Service Shelving
 - a. Selection, quantity, and sizes of shelving shall be decided by the UMBS Committee, program requirements, and configuration of specific project floor plans.
 - b. Shelving shall be freestanding, unless indicated as mobile.
 - c. Install first shelf 10 inches above finish floor with remaining shelves equally spaced.
 - d. Dry Storage Shelving:
 - 1) Bright chrome open-wire shelving or smooth polypropylene with steel core posts and traverses.
 - 2) Minimum weight bearing of 400 pounds at corners and 600 to 800 pounds on straight shelving.

- 3) Shelving shall be guaranteed against rust.
 - 4) Shelf widths shall be between 18 to 24 inches by length to fit individual plan.
 - 5) Stationary shelving shall be 5 tiers high with a post height of 74 inches.
 - 6) Mobile shelving shall be 4 tiers high with a post height of 63 inches, high density stem type casters with at least 2 casters having brakes.
9. Cold Storage and Freezer Shelving:
- a. High density polymer or polypropylene construction.
 - b. Units shall be easy to clean, guaranteed against rust, and able to withstand -35 degree F temperatures.
 - c. Shelving shall be attached to posts marked with 1 to 4 inch increments.
 - d. Shelf widths shall be between 20 to 24 inches by length to fit individual plan.
 - e. Capacity of corner shelves shall be at least 400 pounds and straight shelves shall have a capacity of at least 600 pounds.
10. Pot Pan Shelving shall be standard bright stainless steel open-grid shelving with stainless steel posts.
- a. Shelving and posts shall be non-corrosive and guaranteed against rust.
 - b. Shelf widths shall be 18, 21, or 24 inches by length to suit the project.
 - c. Stationary shelving shall be 5 tiers high with a post height of 74 inches.
 - d. Mobile shelving shall be 4 tiers high with a post height of 63 inches.
 - e. Casters shall be high density stem type with at least 2 casters having brakes.
11. Quality of materials, shop drawing reviews, equipment integrity, and installation shall be a major concern, as UM does not normally receive replacements for as long as thirty years.
12. Building construction quality in food storage, preparation, and serving areas is extremely important. Eliminate gaps between building materials which would allow pests access through floors, walls, or roofs.
13. Equipment and its installation shall be UL listed, if applicable.
14. Installers, service personnel, and contractors for new or existing equipment with refrigerant use shall comply with Environmental Protection Agency (EPA) regulations regarding technician certification and recycling/recovery equipment. See Division 15.

11 51 23 Library Stack Systems

Verify with the UMBS Committee requirements.

11 52 13 Projection Screens

1. Typical projection screens for instructional spaces shall be as follows:
 - a. 70 inches by 70 inches of a durable, matte white, fireproof, viewing surface.

- b. Projection screens shall be manually operated.
 - c. Projection screens shall be wall mounted and not attached to instructional boards. Locate as high as possible to allow bottom edge of projection screen to reach chalk/marker trough of instructional board. Coordinate location of clocks, speakers, robes, and audible alarms.
2. Stage movie screens shall be as follows:
 - a. 15 feet by 15 feet of a durable, matte white, fireproof, viewing surface.
 - b. Stage movie screens shall be roll down and electrically operated.
 - c. Locate screen directly behind the house curtain, concealed from view in roll-up position, and centered on the stage.

11 53 13 Laboratory Fume Hoods and Equipment

1. Please contact the University of Miami for specific equipment and casework requirements. Select equipment and casework according to program requirements.
2. Provide certified performance test reports of materials, equipment, and testing procedures by an independent commercial testing laboratory of the following equipment:
 - a. Safety cabinets
 - b. Fume hoods
 - c. Instructor demonstration tables
 - d. Science tables
 - e. Work tops
 - f. Sink and cup drains
 - g. Mechanical service fittings
3. Laboratory casework, accepted by the UMBS Committee, shall be provided by a single laboratory furniture company.
4. Accessible components shall have a forward approach for accessibility. Parallel wheelchair approach for side access is not acceptable. See accessibility codes for clearances and allowable heights.
5. Faucets, student centers, and other equipment require prior UM acceptance. A combined vandal resistant cold water/gas faucet shall be used in science laboratory student sinks and work stations.
6. Provide tamperproof fasteners and fittings on equipment.
7. Use vacuum breaker fittings on gas, water, or water related items.
8. Laboratory sinks and cup drains shall be black, epoxy resin.
9. Laboratory casework shall include, but not be limited to:
 - a. Tables and Worktops:

- 1) Tops shall be solid epoxy resin tops and sinks and designed to contain spills.
 - b. Cabinets:
 - 1) Provide a clear oak or other clear wood exterior and concealed plywood construction.
 - 2) Flake board, particleboard, and other types of wood composition board are not allowed.
 - 3) Display cabinets shall have sliding wood framed doors with safety glass. Swinging glass doors are not allowed.
 - 5) Provide locks at doors and drawers according to program requirements. Locks within a room shall be keyed alike.
10. Laboratory equipment includes, but not limited to, the following:
 - a. Student Stations:
 - 1) Specify steel support structure and solid epoxy resin tops and sinks.
 - 2) Accessible student stations shall have a forward approach for accessibility. Parallel wheelchair approach for side access is not acceptable. See accessibility codes for clearances and allowable heights.
 - b. Fume Hoods:
 - 1) Provide a forward approach for accessibility, supplemental air hood, epoxy resin work surface, natural gas, cold water, epoxy resin cup sink, acid waste, electricity, and vapor-proof light.
 - 2) Fume hoods shall comply with SAMA, ASHRAE, NFPA, and other applicable codes.
 - 3) Fume hoods shall be located within the laboratory to allow unimpeded exit in case of a fire or explosion within the fume hood. Locate hoods away from paths of egress.
 - 4) Provide unifacial and bifacial fume hoods according to program requirements. Fume hood selection will dictate room layout due to access requirements of each fume hood type.
 - 5) Locate fume hoods away from high traffic areas and provide sufficient aisle space for access.
 - 6) Safety devices such as drench shower/eye wash stations and fire extinguishers shall be located near the fume hood. Locate a floor drain at each drench shower/eye wash station.
 - 7) Fume hood exhaust systems shall be coordinated with the room emergency exhaust system and the supplemental outside air supply, and not interconnected with other ventilation duct systems.
 - 8) Locate emergency exhaust fan switch within 15 feet of the instructor's desk and on the primary egress path.
 - 9) When the emergency exhaust fan is turned on:
 - a) Fume hood exhaust fans shall remain in operation.
 - b) According to NFPA, fume hood supply fans shall automatically shut down.
 - 10) Locate hoods to avoid cross currents and air turbulence at fume hood face due to ventilating inlets or high traffic.
 - 11) At instructor designated fume hoods and at chemistry labs, provide for normal

- laboratory usage with an average face velocity of 100 fpm and a minimum at any one point of 80 fpm.
- 12) At science demonstration classrooms and at physics and biology labs, provide for low toxicity usage with an average face velocity of 75-80 fpm and a minimum at any one point of 50-60 fpm.
 - 13) Fume hood design shall allow for safe and efficient operation during normal laboratory conditions within acceptable specified tolerances when connected to an exhaust system.
 - 14) Dead air pockets and reverse air currents are not allowed along surface of hood interiors.
 - 15) Exhaust and supply system shall be roof mounted with vertical discharge stack on exhaust blower.
 - 16) Required airflow shall be achieved when adjustable baffles are at full-open position.
 - 17) Vision panels shall be safety glass. Polycarbonates, such as "Lexan", are not allowed for glazing materials at view panels.
- c. Safety Components:
- 1) Provide safety cabinets with an emergency shower, eyewash fountain, and storage space for first aid kit, fire blankets, fire extinguisher, and sand bucket. The safety cabinet shall be ADA accessible, easily reached from all areas of the lab, and away from egress paths.
 - 2) An emergency shower shall have a pull valve and pull cord to be held under the shower to wash away chemical contamination. Locate a floor drain at the emergency shower.
 - 3) Eye wash fittings shall have push type flag valves and soft stream heads.
 - 4) Provide a 6 foot long rubber drench hoses and hose spray fittings for deck mounting at instructor demo desk and according to program requirements.

11 61 43 Stage Curtains

1. See UMBS Committee program requirements for specific curtains at auditoriums, cafeterias, language arts labs (little theaters), and CCTV production rooms.
2. Curtain fabrics shall be inherently flame resistant according to FBC stage requirements and NFPA requirements. A sewn-on permanent label shall name the manufacturer and state the fabric is non-combustible.
3. Provide a minimum of 50 percent additional fabric for fullness and box pleats. Provide double bottom hems, canvas chain pocket, and chains at full-length curtains.
4. Provide heavy-duty steel tracks and battens with support assemblies not exceeding 6'-0" on center.
5. Provide a pipe grid the full-length of the proscenium opening plus 5'-0" at each side as shown in the UMBS Committee Appendix - Stage Drawings. The pipe grid shall be at 4'-0" on center for hanging the longitudinal battens for the curtain tracks and lighting. Stage curtains shall include:

- a. House (Grand) Curtain:
 - 1) Center bi-parting curtain with manual pulley operation, hung 8 inches behind the front hard wall for the full-length of proscenium opening plus 3'-0" at each side.
 - 2) Two-way traversing, heavy-duty, steel track and accessories.
 - 3) Polyester velour fabric of a solid color or other accepted color.
- b. House Valance:
 - 1) Stationary valance designed to conceal the house curtain tracks and lighting pipes. Hang 4 inches behind the front hard wall and extend 18 to 24 inches below and 6 inches above the proscenium for the full-length of proscenium opening plus 1'-6" at each side.
 - 2) Polyester velour fabric the same color as the house curtain.
 - 3) School initials or monogram may be sewn on the valance.
- c. Leg Curtains:
 - 1) Black polyester fabric, full-length curtains on stationary battens.
 - 2) 6'-0" length with 2'-0" on stage and 4'-0" off stage.
- d. Border Curtains:
 - 1) Black polyester fabric curtains on stationary battens located in front of leg curtains.
 - 2) Provide border curtains with an overall height as the house valance for the full-length of the proscenium opening plus 6'-0" at each side.
- e. Travelers:
 - 1) Black polyester fabric, full-length, center bi-parting curtain with manual pulley operation.
 - 2) Stack stage right and left with 2'-0" remaining on stage.
- f. Back wall Curtain:
 - 1) Black polyester fabric, full-length, center bi-parting curtain with manual pulley operation.
 - 2) Full-length proscenium opening plus 4'-0" at each side.
- g. Back wall Valance:
 - 1) Black polyester fabric valance on a stationary batten.
 - 2) Provide back wall valance with an overall height as the house valance for the full-length of the proscenium opening plus 4'-0" at each side.
- h. Cyclorama:
 - 1) Light blue polyester fabric suitable for theater light projection.

11 66 23 Gymnasium Equipment

Verify with UMBS Committee requirements.

11 66 53 Gymnasium Dividers

Verify with UMBS Committee requirements.

11 82 26 Facility Waste Compactors

1. Compactor use must be approved by the UMBS Committee prior to specifying.
2. Operational Theory
 - a. The waste compactor is served by wheeled “mini-dumpsters” towed behind a powered utility vehicle. The waste compactor’s hydraulically operated forklift arms pick up each mini-dumpster and dump into a receiving bin for trash compaction.
 - b. The outside dimension of the wheeled “mini-dumpster” is 7’-8”. Pedestrian walkways and roads shall be designed with this feature in mind, taking into consideration that each individual building must be accessed and serviced by these “mini-dumpsters”.
 - c. The forklift end of the waste compactor is the same end that is picked up by the delivery truck making the opposite end the end that gets emptied. Consideration shall also be given to providing circulation for the towed mini-dumpster and allowing proper access to the compactor. Exact placement within the service yard, adequate screening and site circulation shall accommodate these features.
3. Location
 - a. Waste compactors shall be located within service yards and placed proximal to kitchens and custodial receiving areas.
 - b. Provide minimum of 50’ unobstructed, straight-in approach to face of dumpster.
4. Site screening option
 - a. If deemed necessary due to location of service yard with respect to surrounding neighborhood, an 8’-0” high reinforced concrete block wall may be placed around the waste compactor.
 - b. Minimum inside dimensions shall be 12’-0” wide x 32’-0” long. Place concrete filled steel pipe bollards around inside perimeter to protect inside of block walls.
5. Pad Construction
 - a. Provide 12’-0” wide x 32’-0” long x 6” thick, concrete pad for waste compactor.
 - b. Pad shall be constructed of 3000 psi concrete reinforced with #3’s spaced at 12” each way on compacted granular base.
6. Approach Apron
 - a. Provide 16’-0” wide x 10’-0” deep x 6” thick, 3000 psi concrete slab approach apron reinforced with #3’s, spaced at 12” each way on compacted granular base.
 - b. Paint diagonal striping on apron with yellow traffic marking paint and label “NO PARKING ZONE” as indicated.
7. Protection
 - a. Protect enclosure and dumpsters with 8’-0” long x 6”Ø steel pipe bollards filled with concrete. Bollards shall be embedded in 3’-0” deep x 12”Ø concrete footing. See drawings for quantity and location.
8. Utilities
 - a. Water: Provide hose bib in adjacent vicinity. Ensure water drains to area catch basin.

- b. Electrical: Provide 60A, 3 Phase 230-V service.
9. Collection Vehicle Data
- a. Roadways shall be designed for refuse trucks weighing 20 tons.
 - b. Trucks are 40 – 50' in length, depending on manufacturer, and require a 76'-0" turning radius measured to the outside front wheel.

DIVISION 12 FURNISHINGS

This chapter identifies criteria for the selection of furnishings with the purpose of establishing minimum standards, acceptable to UM, to be used as the basis of design for UM Coral Gables campus buildings.

- 12.1 General Requirements
 - 12.1.1 Submittals
 - 12.1.2 Workmanship requirements
- 12.2 Codes
- 12.3 Standards
- 12.4 Design Criteria
- 12.5 Specific Requirements (organized by CSI MasterFormat® 2012 Numbers & Titles)

12.1 General Requirements

Only those sections that are used in typical projects are listed below.

The design and selection of furnishings, in concert with other building components, shall produce a building that meets the programmed sustainability rating (LEED rating) of the specific project. These objectives are in line with the objectives of all Divisions and should be coordinated with requirements in Division 1 Section “Sustainable Design Requirements.”

12.1.1 Submittals

Submittals shall include product data, samples, mock-ups, sustainability data, shop drawings, coordination drawings, and maintenance materials submittals.

12.1.2 Workmanship requirements

Refer to specific requirements included herein.

12.2 Codes

1. Florida Building Code.
2. City of Coral Gables, Local Codes and Ordinances.

12.3 Standards

Refer to specific requirements included herein.

12.4 Design Criteria

Refer to specific requirements included herein.

12.5 Specific Requirements (organized by CSI MasterFormat® 2012 Numbers & Titles).

12 21 13	Horizontal Louver Blinds
12 24 13	Roller Window Shades
12 36 40	Stone Countertops
12 36 61	Simulated Stone Countertops
12 48 16	Entrance Floor Grilles
12 61 00	Fixed Audience Seating
12 93 00	Site Furnishings

12 21 13 Horizontal Louver Blinds

Design Standards

General

This section addresses the requirements for manually operated horizontal louver blinds.

1. Use of motorized blinds must be approved by the UMBS Committee.
2. Slats must be aluminum (those with recycled content preferred).
3. Perforated slats are not acceptable.
4. A single neutral color per building shall be selected from manufacturer’s standards.
5. Approved Manufacturers: Hunter Douglas Contract, Levelor Contract, Springs Window Fashions.

Performance Standards

1. Fabrication must comply with WCMA A100.1.
2. Nominal slat thickness shall be no less than 0.008 in.
3. Slat width shall be 1 inch, with 20 mm tape spacing.
4. Headrail shall be equal to Hunter Douglas CD80 integrated headrail system.
5. Lifetime Warranty required.
6. Blinds shall be installed level and plumb in accordance with the manufacturer’s written instructions. The installer shall ensure unencumbered operation of window sash hardware.

12 24 13 Roller Window Shades**Design Standards**

General

This section provides general guidelines for manually operated woven mesh roller window shades.

1. Use of motorized shades must be approved by the UMBS Committee.
2. Approved Product: MechoShades/5 Manual Drive System manufactured by MechoShade Systems, Inc. System. Mecho Slimline not approved for use.
3. Approved Dealer/Installer: Verify with the UMBS Committee.
4. Shadeband material shall be light-filtering, woven stain and fade resistant fabric. Opaque fabrics are not approved.
5. Approved shadeband material: Mechoshade Thermoveil 0900, 1300 and 1500 series. These series contain PVC but currently perform better than the non-PVC EcoVeil option. Only one color per building shall be specified.
 - a. Selection of openness factor should be determined based upon the window orientation and room use. Various degrees of openness may be required in a building. A general guideline for selection is as follows:
 - (1) 5% openness for general purpose
 - (2) 1-3% for rooms requiring room darkening
 - (3) 3% for windows with west orientation
 - b. Darker colors will provide a better view and light control.
 - c. The Design Professional shall provide large shadeband samples for approval prior to specification.
 - d. Up the bolt shadeband orientation is preferred.
6. Shades shall be flush, overhead mounted with an aluminum fascia or installed in a pocket with a bottom closure panel. Drywall pockets are preferred.
7. Unless required by window condition, the direction of shadeband roller shall be regular, from back of roller to keep the shade close to the window.
8. Indicate all required blocking the contract documents.

Performance Standards

- 1, Woven mesh shades shall comply with the following requirements.
 - a. Roller shades shall be fabricated to comply with WCMA A 100.1.
 - b. Shadeband material shall comply with NPFA 701.

2. Installer shall field verify all dimensions; install shades level and plumb in accordance with the manufacturer's written instructions; and insure unencumbered operation of window sash hardware. Metal parts of shade units shall be isolated from concrete mortar to prevent galvanic action.
3. Drawings and specifications shall provide the location and size of the window to receive shades or blinds and details of installation, such as wall-mounted within jambs, surface-mounted, ceiling-mounted, and mounted within pockets or behind valances.
4. Provide the following details:
 - a. Details of shade assembly mounting details, including wiring diagrams for motorized systems
 - b. Position of shades or blinds in relationship to glass or frame surface
 - c. Special conditions at external and internal corners
 - d. Elevations of special installation situations
 - e. Finish (indicated on schedule)
 - f. Type of shade and/or blinds operation and location of controls
5. Shop drawings shall show locations and size of shades, installation details, elevations indicating division between shade units, and location of shade pulls.

12 36 40 Stone Countertops

Design Standards

General

This section provides guidelines for the use of granite countertops and backsplashes. Marble is not permitted without UM approval.

1. Granite surfaces must have factory polished finish; slight pitting is unacceptable.
2. Samples from actual slab shall be provided to the UMBS Committee for approval.
3. Stone must be obtained from a single quarry source.
4. Joint locations must be indicated on drawings. Avoid mitered joints and joints located near cutouts.
5. Continuous support must be provided under countertop. A subtop, made of a sturdy material such as plywood, sized to limit deflection to not more than 1/720 of the span, is the preferred form of support. Where cabinets are not used for support, framing must be provided and must also be rigid enough to limit deflection to no more than 1/720 of the span.

Performance Standards

1. Material must comply with ASTM C 615.
2. Use Water-Cleanable Epoxy Adhesive that complies with ANSI A118.3 and has a VOC content of 65 g/L or less.
3. Use Water-Cleanable Epoxy Grout that complies ANSI A118.3, chemical-resistant, water-cleanable, tile-setting and -grouting epoxy.
4. Specify colorless stain-resistant sealer as recommended by stone producer.

12 36 61 Simulated Stone Countertops**Design Standards**

General

This section provides general guidelines for solid surface material and quartz agglomerate countertops and backsplashes.

1. Simulated stone countertops and backsplashes are acceptable for use for general use conditions including toilet room countertops and window sills. For installations where excessive heat, chemicals, sharp knives or tools will be used verify manufacturer's warranty before proceeding with selection.
2. Use of integral sinks requires approval from the UMBS Committee.
3. Consider products with recycled content such as Avonite Surfaces Recycled Collection.
4. Products that need to be sealed to prevent staining are not acceptable.
5. Use of solid wood edges and trim is not acceptable.
6. Color selection should be neutral.
7. Specify polished finishes for quartz agglomerate as warranties may not apply to products with honed finishes. Honed finishes require more daily maintenance and are not appropriate for high traffic areas.

Performance Standards

1. Simulated stone materials selected must comply with ANSI SS1.
2. Composite wood and agrifiber products must be made without the use of urea-formaldehyde binders or adhesives.

3. Wood materials used in fabrication must be FSC certified.

12 48 16 Entrance Floor Grilles

Design Standards

General

This Section includes the guidelines for the design and materials selection of entrance floor mats and frames and/or entrance floor grilles and frames of the following types:

1. Recessed floor mats or recessed floor grille, including drain pan fabricated from aluminum or stainless steel.
2. Straight grille pattern is preferred.
3. Joints in floor gratings/mats are not permitted unless dimensions exceed maximum available length. Request from fabricator that dimensions exceeding available sized and requiring joints must be approved by Architect and the UMBS Committee before fabrication. Design should use available sizes.

Product Standards

1. Approved Products:
 - a. Exterior Application: (suggestion) Stainless steel grille with stainless steel frame made of 85% post consumer stainless steel; 1/8 o.c. wire spacing; hidden lockdowns. 1-1/8 inch deep grid. Approved Manufacturer: Construction Specialties GridLine G6 or KD Kadee Industries Kadee 98.
 - b. Interior Application: UMBS Committee to select desired options from attached catalog.
2. Fasteners: Fabricated from stainless steel.

Performance Standards

1. Drawings must show locations and recesses in concrete slab for installation of floor mats/grilles.
2. Exterior installation must show drain pan.
3. The installer shall have at least a five-year documented experience in projects of the same size and type.
4. Submittals:
 - a. The Architect shall request shop drawings showing layout and types of floor mat and frames, full-scale sections of typical installations, details of patterns or designs, anchors, and accessories. Shop drawings to include joints, if required.

- b. The Architect shall coordinate shop drawing submittal with concrete work shop drawings showing oversized recess for deferred installation of frames.
- c. The Architect shall request samples for initial selection purposes in form of manufacturer's color charts consisting of actual sections of floor mat and frame materials, showing full range of colors, textures, finishes, and patterns available, for each type of floor mat and frame indicated. Request sample of joints if applicable.

12 61 00 Fixed Audience Seating

Design Standards

General

This section provides guidelines for upholstered fixed assembly seating for auditoriums and lecture halls. It also includes lecture hall tables furnished as part of seating installation.

1. Fixed auditorium seating layouts shall indicate number of seats, aisle widths, accessible aisle seats, wheelchair and companion seat locations, armrest locations, and other options as required by program.
2. Lecture hall seating layouts shall indicate number of seats and fixed tables, aisle widths, wheelchair clearance at tables, back to back clearance of tables and other options as required by program.
3. Fixed seating shall provide all seated people with a clear unobstructed view to the front of the theatre. The need for a tier or raked floor shall be determined by the Design Professional and the UMBS Committee.
4. Fixed seating should be secured to the floor. Rail mounted systems are not acceptable.
5. In auditoriums each seating row should be offset or staggered by one-half width to improve visibility.
6. Seating layouts shall optimize space utilization. Center aisles should be avoided, as the best viewing seats will be lost. The location of aisles shall be determined not only by sightline considerations but also by the requirements for good access both between the rows and to and from the room. Cross aisles to provide better student access to seating is highly desirable.
7. Lecture halls shall have fixed continuous tables with modesty panels. The need for modular power and data systems shall be determined by the UMBS Committee. Type of chair (either movable or fixed) is to be determined on a project by project basis.
8. Accessible fixed tables should be supplied with stackable chairs so stations may be used as regular seating when not in use by individuals using wheelchairs.

9. Provide mock-up sample of all products for UMBS Committee approval.

Product Standards

1. Selection of fixed seating and tables shall take into account durability, ease of maintenance/part replacement, and ergonomic features.
2. Specify single-source responsibilities. Obtain seating, accessories, mounting components, including layout, field dimensions, installation and coordination responsibilities from a single manufacturer. US-made products preferred.
3. All specified seating products must have a demonstrated history in a similar institutional setting for a minimum of 15 years.
4. Manufacturer must have a sustainability program in place and meet the requirements of IEQ 4.4 and IEQ 4.5. Products that contribute to Materials and Resource credits are preferred.
5. Fixed auditorium seating components shall be ADA compliant and selected from the manufacturers standard product options and shall include:
 - a. Floor mounted one-piece cast iron standards
 - b. Steel inner back, padded upholstered outer plastic back with ergonomic support
 - c. Plastic armrests
 - d. Decorative end panel over durable core at aisles
 - e. Painted steel seat bottom, upholstered molded polyurethane seat cushion with serpentine springs. Self-rising seat mechanism.
 - f. Multiple seat and back width options.
 - g. Clear aisle space with folding tablet arms must meet Life Safety code NFPA 101
 - h. The folding tablet arm support mechanism shall be robust and require minimum maintenance. The tablet surface will have a durable laminated writing surface, on a hardwood plywood core, with rounded edges. 10% must be mounted on the left hand side of aisle seats. Size of tablet to be determined on a per project basis.
 - i. Use of seat numbers and other options shall be determined by the Design Professional and UM.
 - j. Fabrics for upholstered seating must be carefully chosen for suitability in terms of appearance and durability. Fabrics must be commercial upholstery grade, with a minimum of 100,000 double rubs, Wyzenbeek method, and approved by the manufacturer for the intended purpose. Selected fabrics shall be stain resistant. Special care should be taken by the seat manufacturer to ensure that the fabric can be treated with a stain resistant compound and that the treatment is compatible with the permanent adhesive bonding of padding materials.
6. Fixed tables shall be ADA compliant and selected from the manufacturers standard product options and shall include:
 - a. Tables are to be custom manufactured to the specific room size for each project. Multiple table configurations must be offered.
 - b. Epoxy powder coat painted metal legs with steel floor attachment plate.

- c. Table top shall be 1-1/4" thick consisting of a 45 lb/cu ft density particle board core to which a .050" high pressure laminate has been bonded to the top surface with a .050" backing sheet bonded to the bottom surface for a balanced construction. Composite wood products must be made without urea formaldehyde.
 - d. Table end corners shall have radius edges.
 - e. Table edges shall be 3mm polypropylene adhered to the edge with permanent heat cured adhesive.
 - f. Wood spline and tight joint fasteners shall be used to join adjacent table surfaces forming a continuous table top.
 - g. Modesty panels shall be specified; chair support, aisle end panels, power and data units and other options shall be specified if requested by the UMBS Committee.
7. Acceptable Manufacturers:
- a. American Seating Col.
 - b. Hussey Mfg. Co.
 - c. Irwin

Performance Standards

1. Seating products must be manufactured to comply with ASTM F 851 and BIFMA X5.4.
2. Fire-Test- Response Characteristics of Upholstered Chairs:
 - a. Fabric: Class 1 according to DOC CS 191-1953 or 16 CFR 1610, tested according to California Technical Bulletin 117.
 - b. Padding: Comply with California Technical Bulletin 117.
 - c. Full-Scale Fire Test: Comply with California Technical Bulletin 133.
3. Comply with ADA –ABA Accessibility Guideline, Life Safety NFPA 101, Florida Building Code or International Building Code (whichever is more stringent) for accessibility, aisle and egress requirements.
4. Comply with recommendations of seating manufacturer for secure and proper installation.
5. Install chairs using manufacturer's recommended hardware and fasteners. Chairs in curved rows shall be installed at a smooth radius.
6. Mounting bolts and assembly hardware shall be cut, capped and/or otherwise finished to achieve both a finished appearance to the installation and eliminate protrusions and sharp edges which could cut and tear.

12 93 00 Site Furnishings

Design Standards

1. Refer to the UMBS Committee Standards for layout and installation requirements. Contact U-Bike Manager.
2. Rack location and minimum count per project LEED requirement.

Product Standards

Recommended Bike Rack: Bola, Landscapeforms.

Performance Standards

All standard units made from ASTM A53/A500 SCHD 40 steel pipe (2.375"OD x .154 wall), hydraulically bent with a mandril, hot-dipped galvanized after fabrication.

DIVISION 13 SPECIAL CONSTRUCTIONS

This chapter identifies criteria to program and design of both special construction components as defined herein for UM buildings with the purpose of establishing minimum standards, acceptable to UM, to be used as the basis of design and use for UM Coral Gables Campus buildings.

- 13.1 General Requirements
 - 13.1.1 Submittals
 - 13.1.2 Workmanship Requirements
- 13.2 Codes and Standards
- 13.3 Design Criteria
- 13.5 Specific Requirements (Organized by CSI Master Format 2012 Number and Titles).

13.1 General Requirements

Before the start of construction on new buildings and/or major renovations, the Contractor shall provide a drawing for each building floor level showing the coordination of all structural, architectural and MEP items. This includes, but is not limited to: Structural members, floor plates, architectural ceilings, soffits, smoke barriers, fire walls, vertical shafts, sleeves, fire dampers, HVAC ductwork and equipment, plumbing piping and equipment, fire protection piping and equipment, alarm systems, communications, electrical distribution and equipment, lighting, controls, BMS, lighting protection, security systems, etc.

The design use and implementation of special equipment shall provide in a manner to foster an efficient environment for the users and should be considered with the following objectives during the design process:

1. Cost
2. Life cycle
3. Longevity
4. Aesthetics
5. Maintenance
6. Warranty
7. Occupant Safety
8. Sustainable Designs

Quality of materials, shop drawings, reviews, equipment integrity and installation shall be a major concern of the A/E, as University of Miami. All special construction items are intended for long term usage for the general public designed with specific emphasis for the occupants, disabled and custodial use.

13.1.1 Submittals

Submittal shall include product data, Green Sustainable (LEED) Submittals, Shop drawings, samples and closeout submittals as defined in applicable specification sections.

13.1.2 Workmanship Requirements

Refer to specific requirements included herein.

13.2 Code and Standards

1. Florida Building Code (FBC)
2. National Fire Protection Code (NFPA)
3. Underwriter’s Laboratory (UL)
4. American Society of Civil Engineers (ASCE / SEI 7).
5. American with Disabilities Act and Accessibility Guidelines (ADA).
6. Specific product manufacturer requirements
7. City of Coral Gables Ordinances, Zoning and Architectural Requirements

13.3 Design Criteria

Refer to specific requirements under each section included herein.

**13.4 Specific Requirements
(Organized by CSI Master Format® 2012 Numbers & Titles)**

13 24 16	Saunas
13 27 00	Vaults

13 24 16 Sauna

Design Standards

This section provides general guidelines and recommendations for the design and selection of modular and precut saunas.

1. Field Conditions
 - a. Environmental Limitations: Do not install saunas until building is enclosed, wet work in spaces is complete and dry, and HVAC system is operating and will maintain temperature and relative humidity at occupancy levels during the remainder of the construction period.
 - b. Field Measurements: Verify all openings and dimensions for precut saunas by field measurements before fabrication and indicate complete measurements on Shop Drawings.
 - c. Locate any concealed framing, blocking, and reinforcements that support precut saunas by field measurements before being enclosed and indicate measurements on Shop Drawings.

2. Warranty
 - a. Provide and specify a five (5) year warranty from the date of substantial completion of the project in which the manufacturer agrees to repair or replace components of sauna heaters that fail in materials or workmanship within specified warranty period that includes heating elements, controls and safety mechanisms. Also include deterioration of corrosion of metals or metal finishes.

3. Green Sustainable (LEEDS) Submittals
LEED Submittals (When Required):
 - a. Certificates for Credit MR 7: Chain-of-custody certificates indicating that wood and wood-based products comply with forest certification requirements. Include documentation that manufacturer is certified for chain of custody by an FSC-accredited certification body. Include statement indicating cost for each certified wood product.
 - b. Product Data for Credit EQ 4.4: For composite wood products, provide documentation indicating that product contains no urea formaldehyde.
 - c. Laboratory Test Reports for Credit EQ 4: For composite wood products, documentation indicating that products comply with the testing and product requirements of the California Department of Health Services' "Standard Practice for the Testing of Volatile Organic Emissions from Various Sources Using Small-Scale Environmental Chambers."

4. Sauna System Description(s)
 - a. Electrical Components, Devices, and Accessories: Listed and labeled as defined in NFPA 70, by a qualified testing agency, and marked for intended location and application.
 - b. Safety Glazing Labeling: Where safety glazing labeling is indicated, permanently mark glazing with certification label of the SGCC, the manufacturer, or another certification agency acceptable to authorities having jurisdiction. Label shall indicate manufacturer's name, type of glass, thickness, and safety glazing standard with which glass complies.

5. Modular Saunas
 - a. Provide manufacturer's standard demountable, panelized system complete with framing, insulation, vapor retarders, prehung door, and trim; designed to be freestanding.
 - b. Framing: 2-by-2-inch-nominal kiln-dried, Douglas fir.
 - c. Insulation: 3-1/2-inch fiberglass batt with integral foil face or with separate foil vapor retarder.
 - d. Interior Wall and Ceiling Paneling: 1-by-4-inch-nominal V-joint, tongue-and-groove wood boards of species and grade indicated; sanded smooth; kiln dried to no more than 12 percent moisture content.
 - 1) Wood Species: White Aspen (no knots).

- e. Exterior Wall Finish: 11/32-inch thick, grade B lumber or rough-sawn mahogany hardwood plywood prepared to receive gypsum board and owner indicated wall finish if so requested.
- f. Flooring: Manufacturer's standard removable 1-by-4-inch-nominal wood duckboards, of same species as interior paneling, spaced not more than 1/2 inch apart and mounted on preservative-pressure-treated wood sleepers.
- e. Wood Doors: Manufacturer's standard prehung door assembly as follows:
 - 1) Door Wood Species: Same wood species as interior paneling.
 - 2) Jamb, Casing, and Threshold Wood Species: Same wood species as interior paneling.
 - 3) Size: 36 by 80 inches.
 - 4) Glass Vision Panel: Insulating-glass unit made from two lites of 3-mm-thick, clear, tempered float glass with 1/4-inch airspace.
 - a) Provide decorative etched glass door panel showing University of Miami logo.
 - 5) Low-Emitting Materials: Fabricate doors with adhesives and composite wood products that do not contain urea formaldehyde.
 - 6) Low-Emitting Materials: Fabricate doors with adhesives and composite wood products that comply with the testing and product requirements of the California Department of Health Services' "Standard Practice for the Testing of Volatile Organic Emissions from Various Sources Using Small-Scale Environmental Chambers."
 - 7) All-Glass Doors (optional): Manufacturer's standard prehung door assembly of 8-mm-thick, clear, tempered float glass; mounted on 2-inch thick same wood species as interior paneling for jambs and head.
 - a) Provide decorative etched glass door panel showing University of Miami logo.
 - b) Size: 36 by 80 inches.
 - 8) Door Hardware: Provide one pair of brass butt hinges, one self-closing brass center hinge and two wood door pulls of same wood species as interior paneling for each door.
 - 9) Sidelights: Insulating-glass units made from two lites of 3-mm-thick, clear, tempered float glass with 1/4-inch airspace. Provide jamb and casing of same wood species as interior paneling.
 - 10) Benches: Fabricate from S4S, 1-by-4-inch-nominal wood, spaced not more than 1/2 inch apart and supported by 2-by-4-inch-nominal wood framing; of same wood species as interior paneling.
 - 11) Base and Trim: Same wood species as interior paneling.
- 6. Precut Saunas
 - a. Provide manufacturer's standard precut components, vapor retarder, prehung door, and trim; designed for installation over existing framing.
 - b. Interior Wall and Ceiling Paneling: 1-by-4-inch-nominal, V-joint, tongue-and-groove wood boards of species and grade indicated; sanded smooth; kiln dried to no more than 12 percent moisture content.
 - 1) Wood Species: White Aspen (no knots).

- c. Wood Doors: Manufacturer's standard prehung door assembly as follows:
 - 1) Door Wood Species: Same wood species as interior paneling.
 - 2) Jamb, Casing, and Threshold Wood Species: Same wood species as interior paneling.
 - 3) Size: 36 by 80 inches.
 - 4) Glass Vision Panel: Insulating-glass unit made from 2 lites of 3-mm-thick, clear, tempered float glass with 1/4-inch airspace.
 - a) Provide decorative etched glass door panel showing University of Miami logo.
 - 5) Materials: Fabricate doors with adhesives and composite wood products that do not contain urea formaldehyde.
 - 6) Low-Emitting Materials: Fabricate doors with adhesives and composite wood products that comply with the testing and product requirements of the California Department of Health Services' "Standard Practice for the Testing of Volatile Organic Emissions from Various Sources Using Small-Scale Environmental Chambers."
 - d. All-Glass Doors: Manufacturer's standard prehung door assembly of 8-mm-thick, clear, tempered float glass; mounted on 2-inch thick jambs and head.
 - 1) Provide decorative etched glass door panel showing University of Miami Logo.
 - 2) Size: 36 by 80 inches.
 - e. Door Hardware: Provide one pair of brass butt hinges, one self-closing brass center hinge and two wood door pulls of same wood species as interior paneling for each door.
 - f. Sidelights: Insulating-glass units made from two lites of 3-mm-thick, clear, tempered float glass with 1/4-inch airspace. Provide jamb and casing of same wood species as interior paneling.
 - g. Benches: Fabricate from S4S, 1-by-4-inch-nominal wood, spaced not more than 1/2 inch apart and supported by 2-by-4-inch-nominal wood framing; of same wood species as interior paneling.
 - h. Base and Trim: Same wood species as interior paneling.
7. Heaters and Controls
- a. Sauna Heater: Manufacturer's standard electric convection unit with stainless-steel elements, stainless-steel interior, stainless-steel exterior, and wire protective top grill. Provide heat-tested, shatter-resistant igneous rocks that are in direct contact with and completely cover heating-unit coils.
 - 1) Capacity: Determined by manufacturer for sauna size indicated.
 - 2) Power Supply: 120 or 208 or 240-V ac depending on availability.
 - 3) Mounting: Wall mounted with bracket or Corner mounted with bracket or Floor mounted with integral floor stand or legs subject to manufacturer recommendations and the intended application.
 - 4) Built-in Mechanical Controls: Manufacturer's standard system mounted integral with heater unit, with thermostat that will limit room temperature to 194 F. degrees and the following features:
 - a) Dial timer that automatically shuts off heater after 60 minutes.

- b) Dial time-delay that allows heater to be preset up to nine hours in advance.
 - 5) Remote Mechanical Controls: Manufacturer's standard system designed for recessed wall mounting, with thermostat and the following features:
 - a) Heater switch
 - b) Light switch
 - c) Heat-indicator light
 - d) Adjustable temperature control
 - e) Dial timer that automatically shuts off heater after 60 minutes.
8. Materials
- a. Certified Wood: Saunas fabricated with wood and wood-based materials produced from wood obtained from forests certified by an FSC-accredited certification body to comply with FSC STD-01-001, "FSC Principles and Criteria for Forest Stewardship."
 - b. Wood Species and Grades: Provide lumber of grades indicated according to DOC PS 20 and the ALSC National Grading Rule provisions of the grading agency indicated.
 - 1) White Aspen: WCLIB or WWPA; Clear Heart.
 - 2) Redwood: RIS; Clear All Heart, VG (Vertical Grain).
 - 3) Douglas Fir: WCLIB or WWPA; Superior, VG (Vertical Grain).
 - 4) Western Hemlock: WCLIB or WWPA; B & BTR - 1 & 2 Clear, VG (Vertical Grain).
 - 5) Alaska Yellow Cedar: WCLIB or WWPA; B & BTR - 1 & 2 Clear.
 - c. Softwood Plywood: DOC PS 1.
 - d. Hardwood Plywood: HPVA HP-1 made with adhesive containing no urea formaldehyde.
 - e. Tempered Float Glass: ASTM C 1048, Kind FT (fully tempered), Condition A (uncoated), Type I (transparent glass, flat), Quality Q3 (glazing select), Class 1 clear.
 - f. Insulating-Glass Units: Factory-assembled units consisting of sealed lites of glass separated by a dehydrated interspaced, qualified according to ASTM E 2190, and complying with other requirements specified.
 - g. Fasteners: Stainless steel or hot-dip galvanized.
 - h. Vapor Retarder: Laminated aluminum foil and kraft-paper vapor barrier with water-vapor transmission rate of no more than as tested according to ASTM E 96/E 96M.
9. Accessories
- a. Provide the following accessories are to be implemented into the design. Provide wood accessories of same wood species as interior paneling unless otherwise indicated.
 - b. Signage should be incorporated into the unit to serve as a warning constructed in the approved materials shall be mechanically attached to the sauna room on the outside stating that:
 - “Warning: do not exceed 30 minutes in sauna. Excessive exposure can be harmful to health. Any person with poor health should consult a physician before entering sauna.”

10. Fabrication
 - a. Fabrication and installation of Saunas shall consider the following fabrication method within this building standard:
 - b. Fabricate saunas to dimensions, profiles, and details indicated. Sand boards smooth and ease edges to a radius of not less than 1/16 inch
 - c. Nail or screw and glue bench components together from bottom side.
 - d. Countersink or conceal all metal fasteners.
 - e. Secure glass in wood frames with removable stops.
 - f. Flush mount junction boxes for heater, control panel, and light fixtures with concealed connecting electrical conduit in modular sauna panels.

13 27 00 Vaults

Design Standards

This section provides general guidelines and recommendations for the specific applications: for factory-formed and field-assembled, modular vault panels and vault doors.

1. Submittals
Delegated-Design Submittal: In addition to the specification section submittal requirements. The additional submittal requirements are to be included for installed products indicated to comply with design loads, include structural analysis data signed and sealed by the qualified professional engineer responsible for their preparation.
2. Delivery, Storage, and Handling
 - a. Deliver modular vault doors wrapped and crated to provide protection during transit and Project-site storage. Do not use non-vented plastic.
 - b. Deliver keys to University of Miami by registered mail or overnight package service.
 - c. Environmental Limitations: Do not deliver or install modular vaults until spaces are enclosed and weather tight, wet work in spaces is complete and dry, and temporary HVAC system is operating and maintaining ambient temperature and humidity conditions at occupancy levels during the remainder of the construction period.
 - d. Field Measurements: Verify actual dimensions of openings by field measurements before fabrication.
3. Materials
 - a. Steel Plate, Shapes, and Bars: ASTM A 36/A 36M
 - b. Steel Sheet: ASTM A 1008/A 1008M, Commercial Steel (CS), Type B
 - c. Stainless-Steel Sheet: ASTM A 666, Type 304
 - d. Aluminum Extruded Bar and Tube: ASTM B 221
 - e. Aluminum Plate and Sheet: ASTM B 209

- f. No shrink Grout: ASTM C 1107, factory-packaged, nonmetallic aggregate grout; noncorrosive; no staining; mixed with water to consistency suitable for application and 30-minute working time.
4. Modular Security Vault Panel
- a. General: Listed and labeled for burglary resistance according to UL 608. Burglary Classification: Class M, 15 minutes net working time.
 - b. Concrete Vault Panels: Modular, interlocking, precast, reinforced, concrete panels with integral penetrations for sprinklers; conduits for power, signal, and communication systems; and ventilating ports. Factory prime paint exposed surfaces of metal pan.
 - c. Panel Connections: Fabricate vault panels with cast-in steel connection plates.
 - d. Ventilating Ports: Comply with UL 680; with same burglary classification as vault walls; located as indicated on Drawings. Fabricate ports integral with special wall panel.
5. Modular Fire Vault Panels
- a. Insulated Panels: Fabricated from ceramic insulation in expanded metal frame; with galvanized-steel sheet vapor barrier on inside vault wall panel face and ceramic insulation gaskets for between-panel connections; with integral penetrations for sprinklers; conduits for power, signal, and communication systems; and ventilating ports.
 - 1) Rating: Class 125, 2 hour(s).
 - b. Standard: Comply with NFPA 232, "Protection of Records."
6. Vault Door and Frame Assemblies
- a. Security Vault Door Assembly: Comply with UL 608; listed and labeled for burglary resistance; with same burglary classification as vault walls.
 - 1) Clear Opening Size: 36 inches wide by 78 inches high.
 - b. Vault Door: Fabricated from all-welded, insulated steel sheet construction thickness as required for rating; with jambs and head shaped to interlock with frame; with full-height, stainless-steel locking bars that engage vertical jambs; with emergency vault ventilator.
 - 1) Cladding: Manufacturer's standard stainless-steel sheet for hinge cover and door and frame surfaces with stainless-steel finish.
 - 2) Provide the following factory-installed features:
 - a) Door contact alarm device
 - b) Heat detector
 - c) Emergency vault ventilator complying with UL 680, with same burglary classification as vault door.
 - d) Pass-through port
 - e) Automatic mechanism that prevents accidental lock-in
 - c. Frame: Beveled entrance frame, tapered no more than 10 degrees, fabricated from stainless-steel sheet of thickness required by UL listing; with removable rear architrave and adjustable wall flange to accommodate wall thicknesses indicated, fabricated to match frame material and finish.
 - 1) Security Door Frame: Designed for grouted installation.

- d. Emergency Vault Ventilators: Comply with UL 680; with same burglary classification as vault walls.
7. Vault Door Hardware and Accessories
- a. General: Provide hardware components as required for specified UL listing.
 - b. Hinges: No fewer than three roller-thrust-bearing hinges of design, size, and weight required for smooth operation of door and to allow full, clear door opening; with hinge cover(s).
 - c. Door Bolts: Permanently lubricated, not less than 11/16 inches in diameter, and fabricated from nickel-plated steel. On each vertical side of door, provide five door bolts that engage frame when extended. Bolts shall automatically retract when handle is operated and automatically extend when door closes.
 - d. Handle: Manufacturer's standard
 - e. Combination Locks for Security Door: Dual-control, UL 768, Group 2, three-tumbler, key change, mechanical type, capable of no fewer than one million possible combinations; with UL 887 listed, three-movement, 144-hour time lock; equipped with UL 140 relocking device that automatically locks bolt when lock is subjected to mechanical attack.
Provide drill-resistant metal plate for protection of lock case and locking mechanism.
 - f. Relocking Devices: UL 140 listed, designed to automatically lock door bolts when vault door is subjected to mechanical or torch attack.
 - g. Escape Mechanisms: Provide emergency operation of lock from vault side of vault door by means of inside door release fabricated from stainless-steel rod.
 - h. Door Closer: Automatic, with electromagnetic system and sensor that releases door on detection of heat or smoke; with 180-degree, hold-open position.
 - i. Sills: Reinforced, formed stainless-steel plate.
 - j. Door Stop: Tube length style.
 - k. Trim: Stainless steel, chromium-plated steel, or other trim standard with vault door manufacturer.
 - l. Day Gates: Manufacturer's standard gate; full width of door opening and designed to restrict entry through modular vault door; with piano-type or self-closing gravity hinges that swing gate into room.
 - 1) Locks: Equip gates with cylinder-type lock, controlled by key on no secure side and by knob on secure side.
 - 2) Stainless-Steel Gates: Round or square, vertical, stainless-steel bar grille; with manufacturer's standard finish.
 - 3) Aluminum Gates: Round or square, vertical, aluminum bar grille; with clear anodic finish.
 - m. Fabricate modular vault panels and vault doors to work as an integrated system that complies with burglary classification indicated.
 - n. Fabricate vault panels from materials and of size, thickness, and perimeter profile required for a complete vault system that complies with UL listing. Design, engineer, and fabricate supplemental structural members as required for spans indicated.
 - 1) Security Vault Panels: Factory prepared with cutouts and pipe sleeves for communication, and signal wiring penetrations.

8. Paint Finishes
 - a. Finish: Manufacturer's standard factory-applied, baked-on paint finish applied to door, frame, and wall flanges.
 - b. Color and Gloss: As selected by Architect from manufacturer's full range.

9. Installation
 - a. Concrete Vault Panels: Connect adjoining vault wall panels by bolting interior, adjoining cast-in plates as required by manufacturer.
 - 1) Five-Sided Construction: Connect vault wall panels to supporting slab by welding continuous 1-1/2-by-1-1/2-inch steel angle to cast-in steel plate in wall panels and bolting to supporting slab.
 - 2) Connect vault wall panels to vault ceiling panels and to each other at vertical corners by welding continuous 1-1/2-by-1-1/2-inch steel angles to cast-in steel plates in wall panels.
 - b. Lightweight, Metal-Clad Laminated Vault Panels: Connect adjoining vault wall panels by bolting interior side and vertical corners of adjoining panels, as required by manufacturer.
 - 1) Five-Sided Construction: Connect vault wall panels to supporting slab by welding continuous 1-1/2-by-1-1/2-inch steel angle to wall panels and bolting angle to supporting slab.
 - 2) Connect vault wall panels to vault ceiling panels at vertical corners by welding.
 - c. Install modular vaults according to manufacturer's written instructions for clearance between exterior of vault panels and other construction.
 - d. After vault is installed, grout perimeter of vault recess flush with top of slab.

10. Demonstration
 - a. Engage a factory-authorized service representative to train University of Miami maintenance personnel to adjust, operate, and maintain modular vault doors.

DIVISION 14 CONVEYING EQUIPMENT

This chapter identifies criteria to program and design of conveying equipment components as defined herein for UM buildings with the purpose of establishing minimum standards, acceptable to UM, to be used as the basis of design and use for new and existing multi-story UM Coral Gables Campus structures.

- 14.1 General Requirements
 - 14.1.1 Submittals
 - 14.1.2 Workmanship Requirements
- 14.2 Codes
- 14.3 Standards
- 14.4 Design Criteria
- 14.5 Specific Requirements (Organized by CSI Master Format 2012 Number and Titles).

14.1 General Requirements

Before the start of construction on new buildings and/or major renovations, the Contractor shall provide a drawing for each building floor level showing the coordination of all structural, architectural and MEP items. This includes, but is not limited to: Structural members, floor plates, architectural ceilings, soffits, smoke barriers, fire walls, vertical shafts, sleeves, fire dampers, HVAC ductwork and equipment, plumbing piping and equipment, fire protection piping and equipment, alarm systems, communications, electrical distribution and equipment, lighting, controls, BMS, lighting protection, security systems, etc.

The design use and implementation of conveying equipment shall provide in a manner to foster an efficient environment for the users and should be considered with the following objectives during the design process by both in-house and outside design and construction professionals:

1. Cost
2. Life cycle costs and expected service life.
3. Long-term vs. short term building ownership and expectations
4. Aesthetics
5. Maintenance
6. Warranty
7. Occupant Safety

The design of conveying equipment, in concert with other building components, shall produce a building that meets the programmed sustainability rating (LEED rating) of the specific project.

14.1.1 Submittals

Submittal shall include product data, submittals, shop drawings, samples and closeout submittals as defined in applicable specification sections.

14.1.2 Workmanship Requirements

Refer to specific requirements included herein.

14.2 Codes

1. Florida Building Code (FBC)
2. City of Coral Gables Ordinances, Zoning and Architectural Requirements

14.3 Standards

1. Bureau of Elevators of the Department of Business Regulations according to Chapter 399 of the Florida Statutes.
2. National Electric Code (NEC)
3. Components, accessories, fabricated parts, and structure requirements shall comply with ANSI / ASME A17.1-1990, ASME A17.2 ASME A17.2.2, ASME A17.2.3 and ANSI A117.1-1986.
4. National Fire Protection Code (NFPA) Sections 101, 252, 70 and 72.
5. Underwriter's Laboratory (UL)
6. American with Disabilities Act and Accessibility Guidelines (ADA).
7. Specific product manufacturer requirements

14.4 Design Criteria

1. Quality of materials, shop drawings, reviews, equipment integrity and installation shall be a major concern. All conveying equipment systems are intended for long term usage of the general public with elevators designed with specific emphasis for the disabled, furniture and equipment transportation and custodial use. When possible elevator components and parts shall be American made.
2. Wheel chair lifts and stairway chair lifts shall not be used in new construction.
3. When the program requires using conveying equipment specifically elevators of all types the elevator speed, size and other requirements shall be determined by an elevator manufacturer's traffic analysis.
4. All elevator drawings and specifications will be reviewed inspected, and permitted by the Elevator Inspections Division of the Miami-Dade County Building and Zoning Department according to the Bureau of Elevators of the Department of Business Regulations State of Florida.

BUILDING STANDARDS

University of Miami

2017 Edition

5. Elevators that face one another, the minimum width between entrances shall no less than 10'-0". Elements that create queues, such as exhibit, directories, etc., shall not be placed in elevator lobbies.
6. Provide or upgrade, as required, elevator controllers, necessary equipment and connections to comply with recall and fire service requirements at projects with elevator ADA upgrades, a fire replacement fire alarm system, or an upgrade fire alarm system. A simple expansion of the system or adding devices zones will not require recall and fir service compliance modifications.
7. The University of Miami, for the most part, governs new construction. It is understood that requirements cannot be met on all renovations / modernizations. Where new equipment is provided the applicable standard will apply. Where it is cost effective or required to retain existing equipment, said equipment shall be brought up to code compliance standard and in like new condition.
8. All equipment must be maintainable by industry trained elevator mechanics. Acceptance of new technologies will only be considered in conjunction with an intensive formal training program conducted by the equipment manufacture installer. Training shall parallel that provide to the installers technicians and include both classroom and field (hands-on) instruction.
9. Maintainability requirement includes the ability to procure replacement parts as well as special tools. The University will not consider equipment that requires special adjusting, trouble shooting, etc., and tools that cannot be purchased through normal purchasing channels. Special tools provided to the university shall include all top level, solid state diagnostic tools and related software documentation which the equipment manufacturer and installer supplies to his adjusters and service personnel. All tools or diagnostic equipment provided as part of the elevator installation shall remain the property of the University of Miami.
10. Please refer to the following minimum requirements for elevator systems to be used at University of Miami:
11. Controls:
 - a. Provide an on/off barrel type key switch at call station of each floor at elevators not for general use.
 - b. Provide corridor push buttons and call stations at each floor for elevators intended for general use at schools or other type of facilities.
 - c. Provide vandal resistant push button targets at cab interior and call stations in hall.
12. Elevator pits shall be waterproofed and designed to provide dry pit area and include the following:

- a. The floor shall be approximately level.
 - b. Fully submersible sump pump and sump pit below hoist way pit floor level with flush metal cover. Provide FBC required sump pit size.
 - c. Size sump pump for a minimum of 3000 gallons/hour per elevator. Coordinate pump size with Architect to assure the pump will completely fit within the sump pit and function correctly.
 - d. Metal ladder, if pit is deeper than 3'-0".
 - e. One grounded duplex receptacle.
 - f. No plastic PVC or plastic pipes in pit.
 - g. An elevator floor pit drain is not acceptable. Elevator pit must have a floor sump pit and pump to a sanitary sewer through a 2" air gap or directly through an oil / water separator to storm sewer or to grade outside the building line each in accordance with discharge permit, regulations and statutes. Coordinate sump pit when applicable with the Architect, Structural Engineer and Electrical Engineer. If an oil/water separator is not feasible, a "smart-pump" or oil minder will be accepted.
13. Elevator Machine Rooms:
- a. The machine room design shall contain only equipment related to the elevator operations as required by ASME A17.1.
 - b. Preferred location is next to the elevator hoist way on the lowest level served by elevator if using hydraulic. Preferred location for traction elevators is directly overhead or adjacent at top floor.
 - c. Provide and indicate 2 hour fire rating for floors, walls and ceiling construction.
 - d. Machine room door (exiting to the interior of the building) shall be a "B" label, fire rated 1-1/2" hour with automatic closure, latching door hardware, panic hardware exit device from interior of the room, and key operated hardware from outside of the room only.
 - e. Provide at least 7'-0" minimum vertical below all solid items (including the lift beam for electric traction elevators) headroom verified as to need by elevator manufacturer. Provide a maximum machine floor to ceiling height of 12'-0".
 - f. Provide adequate ventilation while maintaining required two hour fire rating at walls and roof.
 - g. Constant cooling and heating to maintain temperature range between 65 and 85 degrees F. Maximum relative humidity 85% non-condensing. Must include thermostat.

- h. Provide Class ABC Fire extinguisher.
- i. Provide 1-1/2 hour rated door equipped with a 2-0" x 2-0" inch fusible link louver.
- j. Pipes, ducts and conduits not required for elevator operations are not allowed in the elevator equipment room.
 - 1) Coordinate with designated University of Miami information Technology Services (ITS)-network expansion services will install wire to the elevator equipment room jack.
 - 2) Contractor shall install wire from elevator equipment room jack to elevator speakerphone.
 - 3) Provide sprinkler connected shunt trips for the elevator disconnect.
- 14. Hoist way serving 3 or more floors shall provide positive venting of smoke and hot gases to the exterior. Locate a minimum of 3 square feet of vent area in the hoist way walls for each elevator cab.
- 15. Hoist way door entrances frames, headers and sills shall be grout filled to maintain fire ratings.
- 16. A vandal proof emergency line powered speaker phone shall be installed inside the cab to comply with applicable codes and standards.
 - a. Provide text and Grade II Braille labeling for "EMERGENCY PHONE" and "PUSH TO TALK" signage according to ADA and DCA requirements.
- 17. Elevator alarm button shall be connected to through facility's security system alarm system.
- 18. Provide a 6" radius elevator alarm bell with weather proof mounting at building exterior with an "Elevator Emergency" sign as required by code. The bell shall be connected to emergency power in the elevator room.
- 19. Specify the manufacturer's authorized representative to submit a signed letter acknowledging one of the following:
 - a. Intent to supply University of Miami authorized maintenance contractor with special tools, instructions, computer programs, and any other items necessary to service and maintain elevator.
 - b. Service or maintenance of the elevator does not require specials tools, computer programs, or any other special items, and in the case special tools are required, these tools shall be provided to the Owner.

**14.5 Specific Roofing Requirements
(Organized by CSI Master Format® 2013 Numbers & Titles)**

14 10 00	Dumbwaiter
14 21 00	Electric Traction Elevators
14 21 13	Electric Traction Freight Elevators

14 24 00	Hydraulic Elevators
14 24 13	Hydraulic Freight Elevators
14 41 19	Stairway Chairlifts
14 42 00	Wheelchair Lifts

14 10 00 Dumbwaiter

These sections provide general guidelines and recommendations for the specific applications.

1. Warranty
 - a. Provide and specify a five (5) year warranty from the date of substantial completion of the project in which the manufacturer agrees to repair or replace components of dumbwaiters that fail in materials or workmanship within specified warranty period. Provide a 12 month’s full maintenance by skilled employees or dumbwaiter installer. Include quarterly preventative maintenance, repair or replacement of worn or defective components, lubrication, cleaning and adjusting as required for proper dumbwaiter operations. All parts and supplies shall be manufacturer’s authorized replacement parts and supplies.

2. LEED Submittals:
 - a. "Product Data for Credit EQ 4.4: For composite wood products, documentation indicating that product contains no urea formaldehyde.
 - b. Laboratory Test Reports for Credit EQ 4: For composite wood products, documentation indicating that products comply with the testing and product requirements of the California Department of Health Services' "Standard Practice for the Testing of Volatile Organic Emissions from Various Sources Using Small-Scale Environmental Chambers."

3. Dumbwaiter Description:
 - a. Provide equipment that complies with ASME A17.1.
 - b. Electrical Components, Devices, and Accessories: Listed and labeled as defined in NFPA 70, by a qualified testing agency, and marked for intended location and application.
 - c. Fire rated Door and frame assemblies are to comply with NFPA 80 that are listed and labeled by UL or another testing and inspecting agency acceptable to authorities having jurisdiction, for fire protection rating as indicated, based on testing according to NFPA 252 or UL 10B.

4. Power Dumbwaiters
 - a. Provide manufacturer’s standard pre-engineered, electric or hydraulic dumbwaiter system as per manufacturer’s recommendation for the applicable application and use after manufacturer evaluation.
 - b. Car Platform Size, Height and Rated Load: the UMBS Committee has expressed a minimum car platform size of 36” wide by 36” deep x 36” car inside height clear inside dimensions as a minimum for design standards with a rated load 100 lbs.

- c. Self Supporting Structure: Powered dumbwaiters shall be manufactured to a standard that contains a self supporting structure that is made from steel with self supporting hoist way framing that supports vertical loads of unit only at base with lateral supports only at landing levels.
 - d. Rated Speed: Rated speed shall be no less than 25 fpm.
 - e. Electric Power Supply: Powered dumbwaiter shall use 120 V, 60 Hz, 1 phase, 240 V 60 HZ, 1 phase or 208 V, 60 Hz, 3 phases depending on power availability.
 - f. Electric Driving Machine: this component selection should be provided by the indicated manufacture depending on the use and application of the power dumbwaiter intended use.
 - g. Car recommended manufacturer standard of construction for the following component is recommended:
 - 1) Enclosure: Sound deadened steel panels with welded joints using plywood with a plastic laminate finish.
 - 2) Shelves: two (2) removable shelves matching finish of the walls.
 - 3) Light Fixture: provide manufacturer's light fixture, located in ceiling near front of car.
 - h. Car Entrance: Manually operated vertically biparting doors and the following supplemental features are desired.
 - 1) Automatic Hoist Way-Door Operations: Equip car entrance with connecting linkages to operate hoist way doors at each landing when car is present.
 - 2) Car-Door Vision Panel: Glazed port through car door aligning with vision panel in hoist way door.
 - 3) Material and Finish: Match car-enclosure walls.
 - i. Plastic Laminate Finish: provide manufacturer's standard finish.
5. Other Components
- a. Access Door and Frame: provide manufacturer's standard.
 - 1) Fire Rating: provide a 1 hour with a 30 minute temperature rise of 450 deg. F.
 - b. Control System for Power Dumbwaiters: provide a manufacturer's standard fully automatic, call and send microprocessor control system that responds to momentary push-button signals at each landing and as follows:
 - 1) Cars shall not respond to station calls for service while in transit, for a predetermined time after arrival at a landing, and when doors are open.
 - 2) Noninterference Timer: Adjustable, limited period of time receiving station to gain access to car before it responds to net station call for service.
 - 3) Parking: When delivery has been completed and doors are closed and no calls for service are registered, return car automatically for parking at lowest landing unless specified otherwise by University of Miami for any specific building program.
 - c. Signal Equipment for Power Dumbwaiters: Manufacturer's standard signal equipment at each landing push-button station; including call button, send button for each landing served, and illuminated "car in use" light that flashes when car arrives at landing until door is opened in a recessed station.

- d. If multiple dumbwaiters are to be used then a Master Control Station for Dumbwaiters shall be used as a control station for each dumbwaiter or group of dumbwaiters, located where indicated on the contract documents. Provide keyed switches and pilot lights for shutdown / startup and emergency stop buttons.

14 21 00 Electric Traction Elevators**14 21 13 Electric Traction Freight Elevator****Design Standards**

1. Electric Traction Passenger & Freight Service Elevators
 - a. This section provides general guidelines and recommendations for the specific applications: for electric traction elevators.
 - b. The primary use of the elevator is for students, staff and visitors that are handicapped and not able to use a stairway. The secondary use is for the transport of items that are too bulky or oversized to be moved from floor to stairway. Elevator is not intended for high use and not to be used as a normal means of vertical transportation.
 - c. Electric traction elevators should be considered when building heights exceed 60 feet of travel distance in height and a cab speed of 350 feet per minute or above are required in the building design.
 - d. AV VVVF motor control shall have at least a five year track record of proven performance service.
 - e. Consider the use of an electric traction elevator when budget and energy efficiency are a required component in the building design process of Sustainable Designs (LEED) are a desired component for the indicated building.
 - f. Provide a design where the location of all elevators should be accessible from all locations of the facility.
 - g. Provide a minimum of one 2,500 pound capacity electric traction elevator. Include a 10'-0" clear high car enclosure and 4'-0" wide x 8'-0" high two-speed opening side door and wall padding option for freight use. If the elevator is to be needed for continued university operations, Provide an additional back-up 2,500 pound capacity electric traction elevator with a 10'-0" clear high car enclosure and 3'-6" wide x 8'-0" high opening center door and wall padding for freight use.
2. Quality Assurance
 - a. Installer Qualifications: Elevator manufacturer or an authorized representative who is trained and approved by manufacturer.
 - b. Manufacturer Qualifications: ten (10) years of experience in the manufacturing and installation of electric traction elevators.
 - c. Preinstallation Conference: Elevator manufacturer or the elevator installer shall attend the pre-construction conference and clarify components, conditions, schedules, project coordination, testing and certification with the General Contractor.

3. Life Expectancy
 - a. It is anticipated that new installation or renovated installation will be capable of providing at least 20 years of dependable service before renovation is again considered. The above assumes that a quality, full maintenance program remain in effect throughout the life of the equipment.

4. Submittals
 - a. Delegated-Design Submittal: In addition to the specification section submittal requirements. The additional submittal requirements are to be included for installed products indicated to comply with design loads, include structural analysis data signed and sealed by the qualified professional engineer responsible for their preparation.
 - b. The elevator manufacturer shall provide analysis design criteria and projected populations to conduct a vertical transportation equipment analysis.
 - c. Product Data and Samples: include product data for all elevator components.
 - d. Shop Drawings: include floor plan, elevations, sections and large scale details indicating service at each landing, hoist way, layout of equipment, layout of equipment and signals, cars, guide rails, hoist beam, requirements, access door, hoist way doors and frames, electrical characteristic and connection requirements complying with current State of Florida standards at the time of submittal.
 - e. Warranty Requirements: One (1) year from the date of substantial completion.
 - f. Maintenance Service: One (1) year from the date of Substantial completion, performed during 24 hour emergency call back service for one (1) year commencing on the date of substantial completion. Systematically examine, adjust, clean and lubricate all equipment. Maintain elevator machine room, hoist way and pit in clean condition.

5. New Installation Requirements
 - a. Attend meetings to consult with the Architect and/or University, and design team members to discuss the project program and establish design requirements. Unique requirements of the building or anticipated occupancy and their influence on the vertical transportation systems are identified at this time.
 - b. Establish the analysis design criteria.
 - c. Utilize the selected design criteria and projected populations to conduct a vertical transportation equipment analysis. Select and recommend the most viable alternatives.
 - d. Submit a written report based upon the analysis and preliminary planning indicated on the schematic architectural drawings. Report shall include:
 - 1) A definition of the selected design criteria and terms.
 - 2) Establish criteria to obtain proper levels of vertical transportation service.
 - 3) Results of computer and/or manual study and analysis calculations.
 - 4) Recommended solutions
 - 5) Deviations from the UMBS Committee Building Standards covering vertical transportation equipment, if any.

6. Modernization Requirements
- a. Conduct a detailed survey of the present elevator equipment to determine its condition and potential for reuse in the modernization program.
 - b. Perform a computerized elevator group data logger survey on the elevator groups of three cars or more to determine the “before” modernization average system response times.
 - c. Investigate the building requirements for elevator service and analyze the needs of the present and projected tenants.
 - e. Provide the UMBS Committee with a written report documenting the survey and analysis results. The report shall contain:
 - 1) Recommendations on the types of equipment needed for modernization.
 - 2) A summary of the present equipment that can be retained.
 - 3) Modernization options.
 - 4) Identify current Code requirements, non-code complying building conditions and disabled accessibility requirements.
 - 5) Identify related work required by other trades.
 - 6) Provide a cost estimate for the recommended elevator modernization.
Provide a schedule for the modernization activities.
7. Freight / Service Elevators
- a. Most structures built on the University of Miami campus will not require a dedicated freight / service elevator. In any event, service would require an analysis and presented for the review by the UMBS Committee.
 - b. The following criteria will apply to the use of a freight / service elevator:
 - 1) Any office building with a total gross floor area approaching 250,000 sq. ft. should be designed to include one dedicated freight / service elevator.
 - 2) An additional freight / service elevator should be recommended for each additional 350,000 sq. ft. gross floor area.
 - 3) Classrooms buildings, especially those containing labs, should be considered on an individual basis.
 - 4) Freight / service elevators should be hospital shaped with a minimum 5,000 lbs. They should be applied with a minimum 10'-0" clear high car enclosure and 4'-0" wide x 8'-0" high, two speed side opening doors.
 - c. In situations which demand the application of a swing / passenger freight / service elevator:
 - 1) It is imperative that swing car be in group operation during peak traffic periods. This shall be accomplished via automatic time clock.
 - 2) Anticipate that the interior finishes of the designated swing car will be damaged by freight / service handlers and not present a good appearance to passengers. Durable stainless steel finishes shall be employed along with freight pads or covers.
 - 3) The best application for a swing car is to have reverse opening in service lobbies at all floors or at least the first floor lobby. This keeps freight out of the main lobbies restricts passenger usage of the elevator and eliminates false corridor call registration which will occur if the normal front door passenger doors are also used for freight / service.

- 4) Swing service cars should be considered in dormitories of five (5) or more stories.
 - 5) At campus settings, true freight elevators are usually considered to support food service functions or transport palletized materials. Due to costs and space considerations, analysis reports shall provide through justification for this type of installation.
7. Approved Manufacturers
- a. Geared and gearless elevators:
 - 1) ThyssenKrupp, Inc.
 - 2) Otis, Inc.
 - 3) Schindler, Inc.
 - 4) KONE, Inc.
8. Microprocessor Group, Car and Motion Control Systems
- a. Group Automatic Operation with Demand –Based Dispatching: provide reprogrammable group automatic system that assigns cars to hall calls based on dispatching program designed to minimize passenger waiting time. System automatically adjusts to demand changes for different traffic conditions including heavy incoming. Heavy two way, heavy outgoing, and light hours as variations of normal two way traffic.
 - 1) ThyssenKrupp, Inc. TAC50
 - 2) Otis, Inc. Elevonic
 - 3) Schindler, Inc. Miconic TX
 - 4) KONE, Inc. KCM 831
 - 5) MCE and CEC Controllers
 - b. Optional Controls: Touchscreen Control Systems
 - a. Use of touchscreen controls shall be reviewed and approved by UMBS prior to design approval.
 - b. Implementation shall involve the implementation of the following components into the design consisting of:
 - i. Touchscreen panels (ADA compliant, low voltage, bright, resolution including wide angle 178° horizontally and vertically). Using a LCD integral touch-sensitive glass panel and watertight bezel model 21 inch screen minimum.
 - ii. CPU Panels solid state device (to control the system).
 - iii. Elevator interface Unit (EIU) for communication with elevator controller.
 - iv. Service port (to access the system for maintenance of configuration with two keyed switches).
 - v. Keypads or buttons (as required for code compliance) using ADA standards and accessible design and ASME A17.1-2007 that is vandal resistant.
 - c. All touch screens control systems shall be provided by the elevator manufacturer specific to the elevator manufacturer being installed as new construction project or renovation, upgrade.

- d. Refer to the following page indicated photograph of a typical touch screen control elevator cab configured for touchscreen use.

Typical Elevator Touchscreen control configuration for design purposes.



9. Power Requirements
- a. Typically 480V, 3-Phase, 60 Hertz. Power requirements should be carefully confirmed on all modernization projects.
10. Materials
- a. Steel:
- 1) Sheet Steel (Furniture Steel for exposed work): Stretcher-leveled. Cold rolled, commercial-quality carbon steel, complying with ASTM A366, matte finish.
 - 2) Sheet Steel (for unexposed work) hot rolled, commercial-quality carbon steel, pickled and oiled, complying with ASTM A568 and A569.
 - 3) Structural Steel Shapes and Plates: ASTM A7, ASTM and A36.
 - 4) Stainless Steel: Type 302 or 304 complying with ASTM A167, with standard tempers and hardness required for fabrication, strength and durability.
 - 5) Satin Stainless Steel, No. 4: bright directional polish (satin finish). Graining directions as shown or, if not shown, in longest dimension
 - 6) Polished Stainless Steel, No. 8: reflective polish (mirror finish).
 - 7) Textured Stainless Steel: 5WL pattern with .050 inches means pattern depth with bright directional polish (satin finish).
 - 8) Random Stainless Steel: Non-directional, random swirl pattern.
- b. Bronze:
- 1) Stretcher-leveled, re-squared sheets composed of 60% copper and 40% zinc similar to Muntz metal Alloy Group 2, with standard temper and hardness required for fabrication, strength and durability. Clean and treat bronze surfaces before mechanical finish. After completion of the final mechanical finish on the fabricated work, use a chemical cleaner to produce finish matching Architect's sample:
 - 2) Polished Bronze: bright-polished bronze, clear coated (US9) finish with clear organic lacquer coating recommended by fabricator.
 - 3) Fine Satin (Brushed) Bronze: fine satin bronze, clear coated (US10) with clear organic lacquer coating recommended by fabricator. Provide graining direction as shown or, if not shown, in longest direction.
 - 4) Acid-Etched Pattern: provide a bright polished (US9) background selectively acid etched, matte-textured, custom pattern as shown. Acid selection and dilution (if required) recommended by fabricator. After final finishing, coat bronze with clear-organic lacquer coating recommended by fabricator.
- c. Aluminum:
- 1) Aluminum extrusions per ASTM B2221: Sheet and plate per ASTM B209.
- d. Wood:
- 1) Plastic Laminate: ASTM E84, Class A and NEMA LD3.1, fire rated grade (GP-50), Type 7, 0.050" .005" thick: color and texture as follows:
 - 2) Exposed Surfaces: Color and texture selected by Architect.
 - 3) Concealed Surfaces: Manufacturer's standard color and finish.
 - 4) Particle board shall not contain urea formaldehyde. Fire-retardant Treated Particle Board Panels: Minimum ¾" thick backup for natural finished wood and plastic laminate veneered panels, edged and faced as shown, provided

- with suitable anti-warp backing; meet ASTM E84 Class “I” rating with a flame spread rating of 100 or less, registered with local authorities for the application for elevator finish materials.
- 5) Natural Finish Wood Veneer: Standard thickness, 1/40” thoroughly dried conforming to ASME / HPMA HP-1983, Premium Grade, place veneer, tapeless spliced with grain running in direction shown, belt and polished sanded, book matched. Species and finish designated and approved by Architect.
11. Paint: Clean exposed metal of oil, grease, scale and other foreign matter and factory paint one shop coat of Manufacturer’s standard rust-resistant primer. After erection, provide one finish coat of the industrial enamel paint. Galvanized metal need not be painted.
- Prime Finish: Clean all surfaces receiving baked enamel finish of oil, grease and scale. Apply one coat of rust-resistant mineral paint followed by a filler coat over uneven surfaces. Sand smooth and apply final coat of mineral paint.
 - Baked Enamel: prime finish as above. Apply and bake 3 additional coats of enamel in the selected solid color. Powder coat is an acceptable alternative.
 - Marble: Refer to appropriate Specification Section.
 - Carpet: Refer to appropriate Specification Section.
 - Glass: laminated safety glass, minimum 9/16” thick, conforming to ANS! Z97.1.
12. Car Performance
- Speed: Traction Elevator 3% of contract speed under any loading condition.
 - Capacity: Safely lower, stop and hold up to 125% of the rated load.
 - Stopping Accuracy: Traction Elevators: ¼” under any loading condition.
 - Door Opening Time*: Seconds from start of opening to fully open: 4’-0” wide, side opening doors: Traction 2.5 seconds.
*Values based on a 7’-0” to 7’-6” high doors. For 7’-6” to 8’-6” high doors, add the following factor to door open and door close time: .5 seconds for width up to 42” and 1 second for widths over 42”.
 - Door closing Time: Seconds from start of closing to fully close: Door closing time shall be adjusted within Code limits. Shop drawings provided by installer shall indicate pertinent weight data and door close time calculations.
 - Start-to-stop Motion Time* Seconds from start of hoist machine motion until machine motion comes to a complete stop with car level and stopped at next successive floor under any loading conditioning or travel direction (12’-0” typical floor height; adjust .2 seconds per foot of travel on traction equipment:
 - Traction at 200 f.p.m.: 6.5 seconds
 - Traction at 350 f.p.m.: 5.6 seconds.
 - Traction at 450 f.p.m.: 5.2 seconds
 Values are based upon a 3’6” wide, center opening doors. If necessary adjust per “d” above.
 - Floor-to-Floor performance Time*: Seconds from start of doors closing until doors are ¾” (2 open for side opening doors) and car level and stopped at next successive floor under any loading condition or travel on traction equipment.
 - Traction at 200 f.p.m.: 10.0 seconds
 - Traction at 300 f.p.m.: 9.1 seconds
 - Traction at 450 f.p.m.: 8.7 seconds.

- h. Ride Quality (Geared Traction):
 - 1) Horizontal acceleration within car during all riding and door operating conditions; not more than 15 mg peak to peak in the 1-10 Hz. Range.
 - 2) Acceleration and Deceleration; Smooth constant and not more than 3 feet/second/second with an initial ramp between 0.5. and .75 second.
 - 3) Sustained Jerk: Not more than 6 feet/second/second squared.
- i. Airborne Noise: Measured noise level of elevator equipment and its operation shall not exceed 50 dBa in elevator lobbies and 60 dBa inside elevator car under any condition including door operation and car ventilation exhaust blower at its highest speed.

14 24 00 Hydraulic Elevators**14 24 13 Hydraulic Freight Elevators****Design Standards**

This section provides general guidelines and recommendations for the specific applications: for hydraulic elevators.

1. The primary use of the elevator is for students, staff and visitors that are handicapped and not able to use a stairway. The secondary use is for the transport of items that are too bulky or oversized to be moved from floor to stairway. Elevator is not intended for high use and not to be used as a normal means of vertical transportation.
2. Hydraulic elevators should be considered when building heights do not exceed 60 feet of travel distance in height (considered low rise) and when a cab speeds of 200 feet per minute or below are required in the building design.
3. Consider the use of a hydraulic elevator when budget and energy efficiency are a required component in the building design process of Sustainable Designs (LEED) are a desired component for the indicated building.
4. Provide a design where the location of all elevators should be accessible from all locations of the facility.
5. Provide a minimum of one 2,500 pound capacity hydraulic elevator. Include a 10'-0" clear high car enclosure and 4'-0" wide x 8'-0" high two-speed opening side door and wall padding option for freight use. If the elevator is to be needed for continued university operations, Provide an additional back-up 2,500 pound capacity electric traction elevator with a 10'-0" clear high car enclosure and 4'-0" wide x 8'-0" high opening center door and wall padding for freight use. The Hydraulic elevators addressed shall be of the following types:
 - a. Direct Plunger Hydraulic Elevator
 - 1) Direct Plunger Hydraulic elevator may be employed for a travel distance up to 60 feet with the following considerations:

- 2) Contract speed shall not exceed 200 feet per minute.
 - 3) Elevator analysis must demonstrate that a hydraulic application will meet the the UMBS Committee Criteria for proper elevator service.
 - 4) Calculations to determine anticipated up-starts per hour per hour shall accompany the elevator analysis reports. U-starts per hour shall not exceed 120.
 - 5) Machine rooms, where possible. Shall be located at the bottom terminal floor, adjacent to the hoist way.
- b. Hole-less Hydraulic Elevator Equipment:
- 1) Cantilevered units will not be considered. Dual jacks will be provided on all installation.
 - 2) Telescoping jacks will not be considered.
 - 3) Travel distances shall not exceed 30 feet.
- c. Quality Assurance
- 1) Installer Qualifications: Elevator manufacturer or an authorized representative who is trained and approved by manufacturer.
 - 2) Manufacturer Qualifications: ten (10) years of experience in the manufacturing and installation of hydraulic elevators.
 - 3) Pre-installation Conference: Elevator manufacturer or the elevator installer shall attend the pre-construction conference and clarify components, conditions, schedules, project coordination, testing and certification with the General Contractor.
- d. Life Expectancy
- 1) It is anticipated that new installation or renovated installation will be capable of providing at least 20 years of dependable service before renovation is again considered. The above assumes that a quality, full maintenance program remain in effect throughout the life of the equipment.
- e. Submittals
- 1) Delegated-Design Submittal: In addition to the specification section submittal requirements. The additional submittal requirements are to be included for installed products indicated to comply with design loads, include structural analysis data signed and sealed by the qualified professional engineer responsible for their preparation.
 - 2) The elevator manufacturer shall provide analysis design criteria and projected populations to conduct a vertical transportation equipment analysis.
 - 3) Shop drawings: include floor plan, elevations, sections and large scale details indicating service at each landing, hoist way, layout of equipment, layout of equipment and signals, cars, guide rails, hoist beam, requirements, access door, hoist way doors and frames, electrical characteristic and connection requirements complying with current State of Florida standards at the time of submittal.
 - 4) Warranty Requirements: One (1) year from the date of substantial completion.
 - 5) Maintenance Service: One (1) year from the date of Substantial completion, performed during 24 hour emergency call back service for one (1) year commencing on the date of substantial completion. Systematically examine, adjust, clean and

lubricate all equipment. Maintain elevator machine room, hoist way and pit in clean condition.

- f. New Installation Requirements
 - 1) Attend meetings to consult with the Architect and/or University, and design team members to discuss the project program and establish design requirements. Unique requirements of the building or anticipated occupancy and their influence on the vertical transportation systems are identified at this time.
 - 2) Establish the analysis design criteria.
 - 3) Utilize the selected design criteria and projected populations to conduct a vertical transportation equipment analysis. Select and recommend the most viable alternatives.
 - 4) Submit a written report based upon the analysis and preliminary planning indicated on the schematic architectural drawings. Report shall include:
 - a. A definition of the selected design criteria and terms.
 - b. Establish criteria to obtain proper levels of vertical transportation service.
 - c. Results of computer and/or manual study and analysis calculations.
 - d. Recommended solutions.
 - e. Deviations from the UMBS Committee Building Standards covering vertical transportation equipment, if any.
 - g. Modernization Requirements
 - 1) Conduct a detailed survey of the present elevator equipment to determine its condition and potential for reuse in the modernization program.
 - 2) Perform a computerized elevator group data logger survey on the elevator groups of three cars or more to determine the “before” modernization average system response times.
 - 3) Investigate the building requirements for elevator service and analyze the needs of the present and projected tenants.
 - 4) Provide the UMBS Committee with a written report documenting the survey and analysis results. The report shall contain:
 - a. Recommendations on the types of equipment needed for modernization.
 - b. A summary of the present equipment that can be retained.
 - c. Modernization options
 - d. Identify current Code requirements, non-code complying building conditions and disabled accessibility requirements.
 - e. Identify related work required by other trades.
 - f. Provide a cost estimate for the recommended elevator modernization program. Provide a schedule for the modernization activities.
6. Freight / Service Elevators
- a. Most structures built on the University of Miami campus will not require a dedicated freight / service elevator. In any event, service would require an analysis and presented for the review by the UMBS Committee.
 - b. The following criteria will apply to the use of a freight / service elevator:
 - 1) Any office building with a total gross floor area approaching 250,000 sq. ft. should be designed to include one dedicated freight / service elevator.
 - 2) An additional freight / service elevator should be recommended for each additional 350,000 sq. ft. gross floor area.

- 3) Classrooms buildings, especially those containing labs, should be considered on an individual basis.
 - 4) Freight / service elevators should be hospital shaped with a minimum 5,000 lbs. They should be applied with a minimum 10'-0" clear high car enclosure and 4'-0" wide x 8'-0" high, two speed, and side opening doors.
 - c. In situation which demands the application of a swing / passenger freight / service elevator, it is imperative that swing car be in group operation during peak traffic periods. This shall be accomplished via automatic time clock.
 - d. Anticipate that the interior finishes of the designated swing car will be damaged by freight / service handlers and not present a good appearance to passengers. Durable stainless steel finishes shall be employed along with freight pads or covers.
 - e. The best application for a swing car is to have reverse opening in service lobbies at all floors or at least the first floor lobby. This keep freight out of the main lobbies restricts passenger usage of the elevator and eliminates false corridor call registration which will occur if the normal front door passenger doors are also used for freight / service.
 - f. Swing service cars should be considered in dormitories of five (5) or more stories.
 - g. At campus settings, true freight elevators are usually considered to support food service functions or transport palletized materials. Due to costs and space considerations, analysis reports shall provide through justification for this type of installation.
7. Approved Manufacturers
 - a. Hydraulic Elevators:
 - b. ThyssenKrupp, Inc.
 - c. Otis, Inc.
 - d. Schindler, Inc.
 - e. KONE, Inc.
 8. Microprocessor Group, Car and Motion Control Systems
 - a. Group Automatic Operation with Demand –Based Dispatching: provide reprogrammable group automatic system that assigns cars to hall calls based on dispatching program designed to minimize passenger waiting time. System automatically adjusts to demand changes for different traffic conditions including heavy incoming. Heavy two way, heavy outgoing, and light hours a s variations of normal two way traffic.
 - 1) ThyssenKrupp, Inc. TAC 20
 - 2) Otis, Inc. Elevonic
 - 3) Schindler, Inc. Miconic TX
 - 4) KONE, Inc. KCM 831
 - 5) MCE and CEC Controllers
 9. Power Requirements
 - a. Typically 480V, 3-Phase, 60 Hertz. Power requirements should be carefully confirmed on all modernization projects.

10. Materials

a. Steel:

- 1) Sheet Steel (Furniture Steel for exposed work): Stretcher-leveled. Cold rolled, commercial-quality carbon steel, complying with ASTM A366, matte finish.
- 2) Sheet Steel (for unexposed work) hot rolled, commercial-quality carbon steel, pickled and oiled, complying with ASTM A568 and A569.
- 3) Structural Steel Shapes and Plates: ASTM A7, ASTM and A36.
- 4) Stainless Steel: Type 302 or 304 complying with ASTM A167, with standard tempers and hardness required for fabrication, strength and durability.
- 5) Satin Stainless Steel, No. 4: bright directional polish (satin finish). Graining directions as shown or, if not shown, in longest dimension
- 6) Polished Stainless Steel, No. 8: reflective polish (mirror finish).
- 7) Textured Stainless Steel: 5WL pattern with .050 inches means pattern depth with bright directional polish (satin finish).
- 8) Random Stainless Steel: Non-directional, random swirl pattern.

b. Bronze:

- 1) Stretcher-leveled, re-squared sheets composed of 60% copper and 40% zinc similar to Muntz metal Alloy Group 2, with standard temper and hardness required for fabrication, strength and durability. Clean and treat bronze surfaces before mechanical finish. After completion of the final mechanical finish on the fabricated work, use a chemical cleaner to produce finish matching Architect's sample.
- 2) Polished Bronze: bright-polished bronze, clear coated (US9) finish with clear organic lacquer coating recommended by fabricator.
- 3) Fine Satin (Brushed) Bronze: fine satin bronze, clear coated (US10) with clear organic lacquer coating recommended by fabricator. Provide graining direction as shown or, if not shown, in longest direction.
- 4) Acid-Etched Pattern: provide a bright polished (US9) background selectively acid etched, matte-textured, custom pattern as shown. Acid selection and dilution (if required) recommended by fabricator. After final finishing, coat bronze with clear-organic lacquer coating recommended by fabricator.
- 5) Aluminum: extrusions per ASTM B2221: Sheet and plate per ASTM B209.

c. Wood:

- 1) Plastic Laminate: ASTM E84, Class A and NEMA LD3.1, fire rated grade (GP-50), Type 7, 0.050" .005" thick: color and texture as follows:
- 2) Exposed Surfaces: Color and texture selected by Architect.
- 3) Concealed Surfaces: Manufacturer's standard color and finish.
- 4) No urea formaldehyde fire-retardant Treated Particle Board Panels: Minimum $\frac{3}{4}$ " thick backup for natural finished wood and plastic laminate veneered panels, edged and faced as shown, provided with suitable anti-warp backing; meet ASTM E84 Class "I" rating with a flame spread rating of 100 or less, registered with local authorities for the application for elevator finish materials.

- 5) Natural Finish Wood Veneer: Standard thickness, 1/40" thoroughly dried conforming to ASME / HPMA HP-1983, Premium Grade, place veneer, tapeless spliced with grain running in direction shown, belt and polished sanded, book matched. Species and finish designated and approved by Architect.
- d. Paint:
 - 1) Clean exposed metal of oil, grease, scale and other foreign matter and factory paint one shop coat of Manufacturer's standard rust-resistant primer. After erection, provide one finish coat of the industrial enamel paint. Galvanized metal need not be painted.
 - 2) Prime Finish: Clean all surfaces receiving a baked enamel finish of oil, grease and scale. Apply one coat of rust-resistant mineral paint followed by a filler coat over uneven surfaces. Sand smooth and apply final coat of mineral paint.
 - 3) Baked Enamel: prime finish as above. Apply and bake 3 additional coats of enamel in the selected solid color. Powder coat finish is also acceptable.
- e. Marble: Refer to appropriate Specification section.
- f. Carpet: Refer to appropriate Specification section.
- g. Glass:
 - 1) Laminated safety glass, minimum 9/16" thick, conforming to ANSI Z97.1.

11. Car Performance

- a. Hydraulic Elevator: 10% of contract speed under any loading condition.
- b. Capacity: safely lower, stop and hold up to 125% of rated load.
- c. Door Opening Time*: Seconds from start to fully open:
- d. 3'-6" wide single-speed, center opening door: Hydraulic 2.1 seconds
- e. 4'-0" wide, single speed center opening doors: Hydraulic 2.2 seconds.
- f. 3'-6" wide side opening doors: Hydraulic 2.3 seconds.
- g. 4'-0" wide, side opening doors: Hydraulic 3.5 seconds.
- h. *Values based on a 7'-0" to 7'-6" high doors. For 7'-6" to 8'-6" high doors, add the following factor to door open and door close time: .5 seconds for width up to 42" and 1 second for widths over 42".
- i. Door closing Time: Seconds from start of closing to fully close: Door closing time shall be adjusted within Code limits. Shop drawings provided by installer shall indicate pertinent weight data and door close time calculations.
- j. Start-to-stop Motion Time* Seconds from start of hoist machine motion until machine motion comes to a complete stop with car level and stopped at next successive floor under any loading conditioning or travel direction (12'-0" typical floor height; adjust .2 seconds per foot of travel on traction equipment:
 - 1) Hydraulic at 100 f.p.m.: 7.0 seconds
 - 2) Hydraulic at 125 f.p.m.: 6.1 seconds.
 - 3) Hydraulic at 150 f.p.m.: 5.2 seconds
 - a. Values are based upon a 3'6" wide, center opening doors. If necessary adjust per "d" above.
- k. Floor-to-Floor performance Time*: Seconds from start of doors closing until doors are $\frac{3}{4}$ " (2 open for side opening doors) and car level and stopped at next successive floor under any loading condition or travel on traction equipment.

- 1) Hydraulic at 100 f.p.m.: 14.0 seconds
- 2) Hydraulic at 125 f.p.m.: 13.0 seconds
- 3) Hydraulic at 150 f.p.m.: 12.5 seconds

14 41 19 Stairway Chairlifts

1. Vertical platform lifts or inclined wheelchair lifts are not allowed at new construction. Provide lifts only as part of a renovation to existing construction and with UMBS Committee approval.
2. Vertical platform lifts or inclined wheelchair lifts shall be provided at stages only if accessibility to a stage cannot be obtained by means of a ramp at renovation or remodeling projects due to space restrictions.
3. For future portable vertical lifts, see program requirements for locations with required provisions at music classrooms with risers.
4. Lifts shall not be installed in a required means of exit.
5. Floor penetrations are not allowed.
6. Platform floors and ramps shall be slip resistant.
7. Provide platform / wheelchair lift with key or key card unlocking and constant pressure controls for operation.
8. Platform / wheelchair lifts shall be sized according to accessibility requirements.
9. Static load ratings shall comply with ANSI/ASME A17.1.
10. Lift machinery shall be designed and constructed with secure shielding devices for the pulling chain, cable, or other operating machinery. Equipment with exposed chains, rollers, sprockets, cables, and other potential pinch points will not be accepted for use in school facilities.
11. Switch controls shall include call / send, up / down, emergency stop, reset, and power folding when applicable.
12. Platform / wheelchair lifts shall be UL listed and of weatherproof construction.
13. Platform / wheelchair lifts shall be capable of both attendant and user control operation.
14. Platform / wheelchair lifts shall be connected to emergency power and able to be lowered by manual operation.

15. Platform / wheelchair lifts require model and manufacturer acceptance by University of Miami
 - 1) Hydraulic at 100 f.p.m.: 7.0 seconds

16. Ranked in order of preference, platform / wheelchair lifts may be one of the following:
 - a. Portable Vertical Platform Lift:
 - 1) A portable vertical platform lift is not-in-contract (NIC).
 - 2) Lift shall have solid transparent sidewalls and gates at least 42 inches high above car platform.
 - 3) Provide perimeter obstruction sensors at the platform bottom surface to stop the unit.
 - 4) Provide a folding self-contained ramp.
 - 5) Install tamperproof gate locks interlocks to:
 - a) Prevent platform movement from a landing unless the gate or door is closed and locked.
 - b) Prevent gate or door opening unless the platform is at the appropriate landing.
 - 6) Provide a loading dock plate to bridge the gap between the lift and the stage.
 - 7) Attach permanently affixed wheels.
 - 8) The lift location, shall be adjacent to power requirements, be on a level surface, and not reduce required egress while in use.
 - b. Vertical Platform Lift:
 - 1) The hoistway shall be guarded by a solid enclosure, fixed or telescoping, extending from the lower landing to a minimum 42 inches above the upper landing when the platform is in the raised position.

 - 2) Gate locks shall be tamperproof interlocks to:
 - a) Prevent platform movement from landing unless the gate or door is closed and locked.
 - b) Prevent gate or door opening unless the platform is at the appropriate landing.
 - 3) Platform guard enclosure shall be solid and be at least 42 inches high above car platform.
 - 4) Lifts shall have obstruction sensors at the platform bottom surface to stop the unit.
 - 5) Provide a lift speed of 9.6 to 12 feet per minute.

14 42 00 Wheelchair Lifts

1. Stair Mounted Inclined Platform Wheelchair Lifts are not allowed at new construction. Provide only as part of a renovation to existing construction and with UMBS Committee approval:
 - a. Wheelchair lift installations are not allowed at required egress stairs.
 - 1) Lifts are only allowed in a stair not required for exit calculations.

- 2) A lift may be used in non-protected stair.
 - b. The lift platform and guardrails shall be capable power folding and unfolding when not in use or when traveling to a call location.
 - c. Lifts shall have directional obstruction sensors at leading and bottom surfaces of platform to stop the unit.
 - d. A sign shall be posted on the lift saying: "NEVER LEAVE LIFT UNATTENDED ON THE STAIRS – EMERGENCY POWER AVAILABLE"
 - e. Provide a lift speed of 15 to 20 feet per minute.
2. Fire-Rated, Runway-Enclosure Door Assemblies: Assemblies shall comply with NFPA 80 that are listed and labeled by a qualified testing agency, for fire-protection ratings indicated, based on testing at as close to neutral pressure as possible according to NFPA 252.
 - a. Temperature-Rise Limit: Provide doors that have a maximum transmitted temperature end point of not more than 450 deg F above ambient after 30 minutes of standard fire-test exposure.

DIVISION 21 FIRE SUPPRESSION

- 21.1 General Requirements
 - 21.1.1 Submittals
- 21.2 Codes
- 21.3 Standards
 - 21.3.1 Fire Protection System Design Standards
- 21.4 Fire Suppression Design Criteria
 - 21.4.1 General Requirements
 - 21.4.2 Water Based Fire Protection Systems
 - 21.4.3 Non-Water Based Fire Suppression Systems
- 21.5 Specific Fire Suppression Requirements
(Organized by CSI MasterFormat 2013 Numbers & Titles)

21.1 General Requirements

This chapter identifies criteria for the program and design of fire suppression systems with the purpose of establishing minimum standards, acceptable to UM, to be used as the basis of design for UM Coral Gables campus buildings. The design of the fire suppression systems shall comply with the following general objectives:

1. Life Safety – for the public, building occupants and emergency responders by minimizing fire related injuries as well as prevent loss of life.
2. Property Protection – Minimize damage to buildings and its contents from fire.
3. Continuity of Operations – Provide ongoing production or operating capabilities where deemed necessary by the university.
4. Historic Preservation – ensure that intended or unintended operation of fire protection measures do not result in damage or loss of character-defining spaces, features and finishes of existing structures that have been identified by the university as having a historic level of significance.

Building service for typical structures is considered to be 50 years.

21.1.1 Submittals

Submittals shall include coordinated shop drawing plans, technical specifications and reports as well as calculations and engineering judgment statements submitted to the authority having jurisdiction.

21.2 Codes

1. Florida Fire Prevention Code
2. Florida Building Code: Building and Existing Building editions

21.3 Fire Protection System Design Standards

Fire Protection Engineering Documents shall be provided in accordance with Florida Administrative Code (FAC) of the state of Florida statutes as follows:

Department 61:	Department Of Business and Professional Regulation
Division 61G-15:	Board of Professional Engineers
Rule Chapter:	Responsibility Rules of Professional Engineers Concerning The Design of Fire Protection Systems

Applicable codes and standards should be the most recent editions adopted by the State, County and City. The primary documents for these systems are as follows:

1. National Fire Protection Association (NFPA) standards including but not limited to the following:
 - a. No. 1 Uniform Fire Code
 - b. No. 10 Standard for Portable Fire Extinguishers
 - c. No. 13 Standard for the Installation of Sprinkler Systems
 - d. No.13R Standard for the Installation of Sprinkler Systems in Residential Occupancies up to and Including Four Stories in Height.
 - e. No. 14 Standard for the Installation of Standpipe, Private Hydrants, and Hose Systems
 - f. No. 20 Standard for the Installation of Stationary Pumps for Fire Protection
 - g. No. 24 Standard for the Installation of Private Fire Service Mains and their Appurtenances
 - h. No. 2001 Standard on Clean Agent Fire Extinguishing Systems

These requirements are considered minimum for satisfactory system performance during a fire condition. Insurance carrier requirements for the premises may supersede these minimal requirements mandated by the codes and standards. As such, specific property loss prevention required by the insurance carrier shall be confirmed and incorporated accordingly into the fire suppression system design. In the event that applicable codes and standards fail to address specific protection requirements, alternative research and testing as permitted by chapter 471 of the Florida Statutes shall be utilized to demonstrate equivalency. The use of systems, methods, or devices of equivalent or superior quality, strength, fire resistance, effectiveness, durability and safety shall be approved by the authority having jurisdiction.

21.4 Fire Suppression Design Criteria

21.4.1 General Requirements

1. Scope of design for a fire protection system shall be provided protection from fire throughout all proposed building areas. Systems include where applicable the following:
 - a. A supervised automatic wet sprinkler system installed in accordance with NFPA 13
 - b. A wet standpipe system installed in accordance with NFPA 14
 - c. A fire pump system installed in accordance with NFPA 20
 - d. A clean-agent fire extinguishing system installed in accordance with NFPA 2001
2. Structural support required by the fire protection system shall be accounted for as a superimposed dead load on the structural design. Hanging, bracing and restraint of the fire protection system shall be provided in accordance with NFPA 13 and manufacturer recommendations of system components. The superimposed dead load shall be stated as required on the structural engineering documents.
3. Requirements for interlocks, safety related devices, indicators and alarms shall be in accordance with the architectural and fire alarm system designs.
4. All fire suppression system components except for piping and fittings shall be cataloged with a component description, its location and its identification. This information shall be submitted to the University for record and used by operations and maintenance personnel.
5. Install or permanently fasten labels to all fire protection system equipment where it is accessible and visible.

21.4.2 Water Based Fire Protection Systems

1. Water based fire protection systems include wet automatic sprinkler systems, wet standpipe systems and fire pump systems.
2. Point of service shall be provided from the underground municipal water supply or existing fire protection system water supply.

21.4.3 Non-Water Based Fire Suppression Systems

1. A Clean-Agent Fire-Extinguishing System shall be considered only and be an engineered system for total flooding of the hazard area. System consists of a

single-zone above and/or below the ceiling and raised floor of the protected space.

**21.5 Specific Fire Suppression Requirements
(Organized by CSI MasterFormat 2013 Numbers & Titles**

21 11 00	Facility Fire-Suppression Water-Service Piping
21 12 00	Fire Suppression Standpipes
21 13 13	Wet-Pipe Sprinkler Systems
21 22 00	Clean-Agent Fire-Extinguishing Systems
21 31 13	Electric-Drive, Centrifugal Fire Pumps
21 34 00	Pressure-maintenance Pumps
21 39 00	Controllers for Fire-Pump Drivers

21 11 00 Facility Fire-Suppression Water Service Piping

Section includes fire-suppression water-service piping and related components outside the building and service entrance piping through floor into the building and service entrance piping through wall into the building.

Design Standards

1. Point of service shall be provided from the underground municipal water supply or existing fire protection system water supply.
2. Public water supply flow test data shall be provided and include the following information:
 - a. Date of test
 - b. Time of test
 - c. Elevation of outlet
 - d. Static pressure
 - e. Residual pressure
 - f. Hydrant flow
 - g. Available flow at 20 PSI residual
 - h. Friction coefficient
 - i. Hydrant Location
3. Valving of the fire protection system as well as flow and tamper switch designations for the valves shall be specified on the fire protection drawing plans and shall be supervised in accordance with NFPA 13-8.15.1.1.2.1 (2002 Edition). Sprinkler zone control valves and test/drain valve assemblies shall be located wherever possible within exit stairs. Valves shall be located a maximum of 7-feet above the floor level as per NFPA 13-8.16.4.2.

4. Installer shall confirm that there are no conditions in the water supply that may lead to microbial induced corrosion (MIC).
5. Backflow prevention device selection shall prevent the reverse flow of fire protection system water supply from being pumped or siphoned into the potable water supply.
6. A backflow prevention device shall be located and oriented such that it is not in proximity to the main entry of the building. In cases where this is not possible, the device shall be installed such that it is an unobtrusive location, in harmony with the aesthetic nature of the building entry.
7. The isolation valves for the backflow prevention device shall be considered in lieu of a post indicator valve to comply with applicable code for control of the water supply to the fire protection system if the backflow prevention device is serving one building only.
8. Fire Department Connection finish, whether free-standing or wall-mounted shall be coordinated with shall be coordinated with the project architect.

Product Standards

1. Ductile-Iron Pipe and Fittings
Provide products by one of the following:
 - a. Anvil International, Inc
 - b. Shurjoint Piping Products
 - c. Star Pipe Products
 - d. Victaulic Company
2. Tubular-Sleeve Pipe Couplings
Provide products by one of the following:
 - a. Cascade Waterworks Manufacturing
 - b. Dresser, Inc.; Dresser Piping Specialties
 - c. Ford Meter Box Company, Inc. (The); Pipe Products Division
 - d. JCM Industries
 - e. ROMAC Industries Inc
 - f. Smith-Blair, Inc.; a Sensus company
 - g. Viking Johnson
3. Gate Valves
Provide products by one of the following:
 - a. American AVK Company; Valve & Fittings Division
 - b. American Cast Iron Pipe Company; American Flow Control Division
 - c. American Cast Iron Pipe Company; Waterous Company Subsidiary
 - d. Clow Valve Company; a division of McWane, Inc
 - e. Crane Co.; Crane Valve Group; Jenkins Valves

- f. Crane Co.; Crane Valve Group; Stockham Division
 - g. East Jordan Iron Works, Inc.
 - h. Hammond Valve
 - i. Kennedy Valve; a division of McWane, Inc.
 - j. M&H Valve Company; a division of McWane, Inc.
 - k. Milwaukee Valve Company
 - l. Mueller Co.; Water Products Division
 - m. NIBCO Inc.
 - n. Shurjoint Piping Products
 - o. Troy Valve; a division of Penn-Troy Manufacturing, Inc
 - p. Tyco Fire & Building Products LP
 - q. United Brass Works, Inc.
 - r. U.S. Pipe
 - s. Watts Water Technologies, Inc.
4. Tapping-Sleeve Assemblies
Provide products by one of the following:
- a. American Cast Iron Pipe Company; Waterous Company Subsidiary
 - b. Clow Valve Company; a division of McWane, Inc.
 - c. East Jordan Iron Works, Inc.
 - d. Flowserve
 - e. Kennedy Valve; a division of McWane, Inc.
 - f. M&H Valve Company; a division of McWane, Inc.
 - g. Mueller Co.; Water Products Division
 - h. U.S. Pipe
5. Post Indicator Valves
Provide products by one of the following:
- a. American AVK Company; Valves & Fittings Division
 - b. American Cast Iron Pipe Company; American Flow Control Division
 - c. American Cast Iron Pipe Company; Waterous Company Subsidiary
 - d. Clow Valve Company; a division of McWane, Inc.
 - e. Crane Co.; Crane Valve Group; Stockham Division
 - f. Kennedy Valve; a division of McWane, Inc.
 - g. Mueller Co.; Water Products Division
 - h. NIBCO Inc.
 - i. Tyco Fire & Building Products LP
6. Fire Hydrants
- a. Provide products by one of the following:
 - b. American Cast Iron Pipe Company; American Flow Control Division
 - c. American Cast Iron Pipe Company; Waterous Company Subsidiary
 - d. American Foundry Group, Inc.
 - e. Clow Valve Company; a division of McWane, Inc.
 - f. East Jordan Iron Works, Inc.

- g. Kennedy Valve; a division of McWane, Inc.
 - h. M&H Valve Company; a division of McWane, Inc.
 - i. Mueller Co.; Water Products Division
 - j. Troy Valve; a division of Penn-Troy Manufacturing, Inc.
 - k. U.S. Pipe
7. Fire Department Connections
- a. Provide products by one of the following:
 - b. Elkhart Brass Mfg. Company, Inc.
 - c. Fire-End & Croker Corporation
 - d. Guardian Fire Equipment, Inc.
 - e. Kidde Fire Fighting
 - f. Potter Roemer
 - g. Reliable Automatic Sprinkler Co., Inc.

21 12 00 Fire Suppression Standpipes

Design Standards

1. Standpipe system shall be provided for the proposed building as required by applicable codes and standards. A class I automatic, wet standpipe system shall be provided for the purpose of maintaining system pressure and delivering the standpipe system demand without intervention and use from fire department apparatus.
2. Piping material for standpipe systems shall be schedule 40.
3. Hose connections adjacent to standpipes shall be arranged such that the valve does not project into the required stair width at the landing.
4. Hose connections located outside exit stairways shall be wall-mounted within cabinets. Pipe escutcheons shall be installed inside the cabinet where the water-supply piping penetrates the cabinet. These hose connections shall be arranged along the path of egress with the valves installed such that connection of fire hose is possible.
5. Hose Connection outlets shall be male hose threads with lugged cap, gasket, and chain. Hose valve threads shall be in accordance with NFPA 1963 and match City of Coral Gables fire-department threads.
6. Structural support required by the standpipe system shall be accounted for as a superimposed dead load on the structural design. Hanging, bracing and restraint of the fire protection system shall be provided in accordance with NFPA 14 and manufacturer recommendations of system components. The superimposed dead load is stated as required on the structural engineering documents.

Product Standards

1. Check Valves

Provide products by one of the following:

- a. AFAC Inc.
- b. American Cast Iron Pipe Company; Waterous Company Subsidiary
- c. Anvil International, Inc.
- d. Clow Valve Company; a division of McWane, Inc.
- e. Crane Co.; Crane Valve Group; Crane Valves
- f. Crane Co.; Crane Valve Group; Jenkins Valves
- g. Crane Co.; Crane Valve Group; Stockham Division
- h. Fire-End & Croker Corporation
- i. Fire Protection Products, Inc.
- j. Fivalco Inc.
- k. Globe Fire Sprinkler Corporation
- l. Groeniger & Company
- m. Kennedy Valve; a division of McWane, Inc.
- n. Matco-Norca
- o. Metraflex, Inc.
- p. Milwaukee Valve Company
- q. Mueller Co.; Water Products Division
- r. NIBCO Inc.
- s. Potter Roemer
- t. Reliable Automatic Sprinkler Co., Inc.
- u. Shurjoint Piping Products
- v. Tyco Fire & Building Products LP
- w. United Brass Works, Inc.
- x. Venus Fire Protection Ltd.
- y. Victaulic Company
- z. Viking Corporation
- aa. Watts Water Technologies, Inc.

2. Iron OS&Y Gate Valves

Provide products by one of the following

- a. American Cast Iron Pipe Company; Waterous Company Subsidiary
- b. American Valve, Inc.
- c. Clow Valve Company; a division of McWane, Inc.
- d. Crane Co.; Crane Valve Group; Crane Valves
- e. Crane Co.; Crane Valve Group; Jenkins Valves
- f. Crane Co.; Crane Valve Group; Stockham Division
- g. Hammond Valve
- h. Milwaukee Valve Company
- i. Mueller Co.; Water Products Division
- j. NIBCO Inc.
- k. Shurjoint Piping Products

- l. Tyco Fire & Building Products LP
 - m. United Brass Works, Inc.
 - n. Watts Water Technologies, Inc.
3. Indicating-Type Butterfly Valves
Provide products by one of the following
- a. Anvil International, Inc.
 - b. Fivalco Inc.
 - c. Global Safety Products, Inc.
 - d. Kennedy Valve; a division of McWane, Inc.
 - e. Milwaukee Valve Company
 - f. NIBCO Inc.
 - g. Shurjoint Piping Products
 - h. Tyco Fire & Building Products LP
 - i. Victaulic Company
4. Angle Valves and Globe Valves
Provide products by one of the following
- a. Fire Protection Products, Inc.
 - b. United Brass Works, Inc.
5. Ball Valves
Provide products by one of the following
- a. Affiliated Distributors.
 - b. Anvil International, Inc.
 - c. Barnett
 - d. Conbraco Industries, Inc.; Apollo Valves
 - e. Fire-End & Croker Corporation
 - f. Fire Protection Products, Inc.
 - g. Flowserve
 - h. FNW
 - i. Jomar International, Ltd.
 - j. Kennedy Valve; a division of McWane, Inc.
 - k. Kitz Corporation
 - l. Legend Valve
 - m. Metso Automation USA Inc.
 - n. Milwaukee Valve Company
 - o. NIBCO Inc.
 - p. Potter Roemer
 - q. Red-White Valve Corporation
 - r. Southern Manufacturing Group
 - s. Stewart, M. A. and Sons Ltd.
 - t. Tyco Fire & Building Products LP
 - u. Victaulic Company
 - v. Watts Water Technologies, Inc.

6. Nonadjustable-Valve Hose Connections
Provide products by one of the following
 - a. AFAC Inc.
 - b. Elkhart Brass Mfg. Company, Inc.
 - c. Fire-End & Croker Corporation
 - d. Fire Protection Products, Inc.
 - e. GMR International Equipment Corporation
 - f. Guardian Fire Equipment, Inc.
 - g. Kennedy Valve; a division of McWane, Inc.
 - h. Mueller Co.; Water Products Division
 - i. NIBCO Inc.
 - j. Potter Roemer
 - k. Tyco Fire & Building Products LP
 - l. Wilson & Cousins Inc.

Performance Standards

1. Minimum residual pressure at each hose-connection outlet shall be NPS 2-1/2 Hose Connections: 100 psig.
2. Maximum residual pressure at required flow at each hose-connection outlet is as follows unless otherwise indicated for a NPS 2-1/2 (DN 65) Hose Connection shall be 175 psig.

21 13 13 Wet-Pipe Sprinkler Systems

Design Standards

1. Classification of occupancy as per NFPA 13 shall be as follows:
 - a. Offices, residential areas, classrooms, reading areas, study rooms, activity rooms, bar/snack area, sauna, locker rooms, and fitness centers shall be classified as light hazard in accordance with NFPA 13. Reading and stack area, composed of individual bookshelves, tables and chairs shall be classified as light hazard in accordance with NFPA 13.
 - b. Kitchen areas, electrical rooms, storage rooms, pump rooms, mechanical rooms and automobile parking areas shall be classified as ordinary hazard group 1 in accordance with NFPA 13.
 - c. Library large stack room areas, high density file rooms, machine shops and stages shall be classified as Ordinary Hazard Group 2 in accordance with NFPA 13.
2. Fire protection system design shall be as follows:
 - a. Wet pipe automatic sprinkler system and wet standpipe system throughout premises as required by applicable codes and standards.

- b. Control rooms, communication equipment rooms and telecommunication rooms shall be provided with a pre-action type of sprinkler system in lieu of wet-pipe sprinkler protection should non-water based fire suppression be disavowed by the University with a clean agent fire extinguishing system.
- c. Generator rooms shall be provided with high temperature sprinklers.
- d. Building areas provided with ceilings shall be protected with concealed type sprinklers. Color of cover plate assemblies shall be coordinated with ceiling finishes.
- e. Sprinkler piping provided in exterior areas such as covered walkways shall be galvanized.
- f. Sprinkler piping throughout building premises shall be concealed with the exception of exposed ceiling areas.
- g. Sprinkler piping shall be schedule 40 steel pipe.
- h. Areas subject to frequent remodeling shall consider the use of flexible sprinkler hose fittings to facilitate the relocation of sprinklers when the area undergoes a modification.
- i. The roof/ceiling construction assembly of exterior areas, including balconies, terraces and breezeways, where the area beneath is not utilized to store or handle combustibles and comprised of noncombustible material shall have sprinkler protection omitted as permitted by NFPA 13.

Product Standards

- 1. Check Valves
Provide products by one of the following:
 - a. AFAC Inc.
 - b. American Cast Iron Pipe Company; Waterous Company Subsidiary
 - c. Anvil International, Inc.
 - d. Clow Valve Company; a division of McWane, Inc.
 - e. Crane Co.; Crane Valve Group; Crane Valves
 - f. Crane Co.; Crane Valve Group; Jenkins Valves
 - g. Crane Co.; Crane Valve Group; Stockham Division
 - h. Fire-End & Croker Corporation
 - i. Fire Protection Products, Inc.
 - j. Fivalco Inc.
 - k. Globe Fire Sprinkler Corporation
 - l. Groeniger & Company
 - m. Kennedy Valve; a division of McWane, Inc.
 - n. Matco-Norca
 - o. Metraflex, Inc.
 - p. Milwaukee Valve Company
 - q. Mueller Co.; Water Products Division
 - r. NIBCO Inc.
 - s. Potter Roemer
 - t. Reliable Automatic Sprinkler Co., Inc.

- u. Shurjoint Piping Products
 - v. Tyco Fire & Building Products LP
 - w. United Brass Works, Inc.
 - x. Venus Fire Protection Ltd.
 - y. Victaulic Company
 - z. Viking Corporation
 - aa. Watts Water Technologies, Inc.
2. Iron OS&Y Gate Valves
Provide products by one of the following:
- a. American Cast Iron Pipe Company; Waterous Company Subsidiary
 - b. American Valve, Inc.
 - c. Clow Valve Company; a division of McWane, Inc.
 - d. Crane Co.; Crane Valve Group; Crane Valves
 - e. Crane Co.; Crane Valve Group; Jenkins Valves
 - f. Crane Co.; Crane Valve Group; Stockham Division
 - g. Hammond Valve
 - h. Milwaukee Valve Company
 - i. Mueller Co.; Water Products Division
 - j. NIBCO Inc.
 - k. Shurjoint Piping Products
 - l. Tyco Fire & Building Products LP
 - m. United Brass Works, Inc.
 - n. Watts Water Technologies, Inc.
3. Indicating-Type Butterfly Valves
Provide products by one of the following:
- a. Anvil International, Inc.
 - b. Fivalco Inc.
 - c. Global Safety Products, Inc.
 - d. Kennedy Valve; a division of McWane, Inc.
 - e. Milwaukee Valve Company
 - f. NIBCO Inc.
 - g. Shurjoint Piping Products
 - h. Tyco Fire & Building Products LP
 - i. Victaulic Company
4. Ball Valves
Provide products by one of the following:
- a. Affiliated Distributors.
 - b. Anvil International, Inc.
 - c. Barnett
 - d. Conbraco Industries, Inc.; Apollo Valves
 - e. Fire-End & Croker Corporation

- f. Fire Protection Products, Inc.
 - g. Flowserve
 - h. FNW
 - i. Jomar International, Ltd.
 - j. Kennedy Valve; a division of McWane, Inc.
 - k. Kitz Corporation
 - l. Legend Valve
 - m. Metso Automation USA Inc.
 - n. Milwaukee Valve Company
 - o. NIBCO Inc.
 - p. Potter Roemer
 - q. Red-White Valve Corporation
 - r. Southern Manufacturing Group
 - s. Stewart, M. A. and Sons Ltd.
 - t. Tyco Fire & Building Products LP
 - u. Victaulic Company
 - v. Watts Water Technologies, Inc.
5. Freestanding, Fire-Department Connections
Provide products by one of the following:
- a. AFAC Inc.
 - b. Elkhart Brass Mfg. Company, Inc.
 - c. GMR International Equipment Corporation
 - d. Guardian Fire Equipment, Inc.
 - e. Potter Roemer
6. Branch Outlet Fittings
Provide products by one of the following:
- a. Anvil International, Inc.
 - b. National Fittings, Inc.
 - c. Shurjoint Piping Products
 - d. Tyco Fire & Building Products LP.
 - e. Victaulic Company
7. Flow Detection and Test Assemblies
Provide products by one of the following:
- a. AGF Manufacturing Inc.
 - b. Reliable Automatic Sprinkler Co., Inc.
 - c. Tyco Fire & Building Products LP
 - e. Victaulic Company
8. Branch Line Testers
Provide products by one of the following:
- a. Elkhart Brass Mfg. Company, Inc.
 - b. Fire-End & Croker Corporation

- c. Potter Roemer
9. Flexible Sprinkler Hose Fittings
Provide products by one of the following:
- a. Fivalco Inc.
 - b. FlexHead Industries, Inc.
 - c. Gateway Tubing, Inc.
10. Sprinklers
Provide products by one of the following:
- a. Globe Fire Sprinkler Corporation.
 - b. Reliable Automatic Sprinkler Co., Inc.
 - c. Tyco Fire & Building Products LP
 - d. Venus Fire Protection Ltd.
 - e. Victaulic Company
 - f. Viking Corporation

Performance Standards

1. Sprinkler water supply and hose stream for the occupancy classifications shall be as follows:
- a. Light Hazard classification shall utilize density/area curve method (NFPA 13 for a density of 0.10 gallons per minute (GPM) for a minimum remote area of 1500 square feet (ft²). The total combined inside and outside hose stream shall be 100 GPM in accordance with NFPA 13.
 - b. Ordinary Hazard Group 1 classification shall utilize density/area curve method (NFPA 13 for a density of 0.15 gallons per minute (GPM) for a minimum remote area of 1500 square feet (ft²). The total combined inside and outside hose stream shall be 250 GPM in accordance with NFPA 13.
 - c. Ordinary Hazard Group 2 classification shall utilize density/area curve method (NFPA 13 for a density of 0.20 gallons per minute (GPM) for a minimum remote area of 1500 square feet (ft²). The total combined inside and outside hose stream shall be 250 GPM in accordance with NFPA 13.
2. A 10 percent margin of safety for the design pressure of the fire protection system shall be included as part of the calculated demand of the system. The demand shall also include losses through water-service piping, valves, and backflow prevention devices.
3. Sprinkler temperature ratings shall be 155 degrees Fahrenheit throughout all areas of the building except as follows:
- a. Sauna shall have a temperature rating of 286 degrees Fahrenheit
 - b. Skylight area shall have a temperature rating of 175 degrees Fahrenheit
 - c. Elevator pit and machine room space shall have a temperature rating of 175 degrees Fahrenheit.

4. Sprinkler spacing and locations shall be in accordance with sprinkler layout as indicated on fire protection drawing plans.
5. A combination standpipe/riser providing water supply to the sprinkler system shall be provided wherever possible within exit stairs. These risers can also be located in spaces along the perimeter of a building where Fire Department access is provided.
6. Valving of the fire protection system as well as flow and tamper switch designations for the valves shall be specified on the fire protection drawing plans and shall be supervised in accordance with NFPA 13. Sprinkler zone control valves and test/drain valve assemblies shall be located wherever possible within exit stairs. Valves shall be located a maximum of 7-feet above the floor level to ensure accessibility.
7. Fire protection system components identified in the fire protection drawing plans shall be Underwriters Laboratories listed and Factory Mutual approved where applicable to ensure quality of system components. Components shall also be provided in accordance with performance requirements indicated in the fire protection technical specifications.

21 22 00 Clean Agent Fire Extinguishing Systems

Design Standards

1. Clean-Agent Fire Extinguishing System basis of design shall consider the use of FM-200 (HFC-227 EA) or inergen (IG-541) as the extinguishing agent to be utilized.
2. A clean-agent and concentration suitable for normally occupied areas shall be utilized.
3. Total corresponding clean-agent flooding quantity shall be determined in accordance with NFPA 2001 Sections 5.4 and 5.5 and manufacturer data.
4. The basis of design shall include a main and a reserve clean agent cylinder supply configuration to provide 100% of the total flooding capacity.
5. Clean-Agent Fire Extinguishing Systems shall be designed for class B and C fires as appropriate for areas being protected.
6. Clean-Agent Fire Extinguishing System shall be single-zoned and provided with verified smoke detection in the protected areas. Verified smoke detection ensures that clean-agent discharge does not occur without the actuation of two smoke detectors in the protected areas.
7. System Operating Sequence: Smoke and duct smoke detection shall report to a fully Programmable Microprocessor-Based Control Panel programmed to operate as follows:
 - a. Clean Agent Smoke Detection System

- 1) Actuating First Detector: Visual indication on Annunciator Panel, energize audible alarms and visual alarms (slow pulse), shut down air conditioning and ventilating systems serving protected areas, close doors in protected areas, and send signal to Fire Alarm System.
 - 2) Actuating second detector: visual indication on Annunciator Panel, energize audible and visual alarms (fast pulse), shut down power to protected equipment, start time delay for extinguishing agent discharge for 30 seconds, and discharge extinguishing agent.
 - 3) Extinguishing agent will operate audible alarms and strobe lights inside and outside the protected area.
8. Manual stations shall immediately discharge extinguishing agent when activated.
 9. The system shall be configured such that operating abort stations will delay extinguishing-agent discharge while the system was activated, and resetting of switches would be required to prevent agent discharge. Release of hand pressure on the switch will cause agent discharge if the time delay has expired.

Product Standards

1. HFC 227ea Clean Agent: Heptafluoropropane
Provide products by one of the following
 - a. DuPont
 - b. Great Lakes Chemical Corporation; a Chemtura company
2. IG-541 Clean Agent: Mixture of nitrogen, argon, and carbon dioxide inert gases
Provide products by one of the following
 - a. Ansul Incorporated

Performance Standards

1. The design concentration for the extinguishing system shall have a minimum hold time of 10-minutes.
2. Design calculations shall be completed considering the enclosure volume to be maintained at a temperature of 70°F and a pressure of 1 ATM.
3. FM-200 (HFC-227ea)
 - a. Discharge HFC 227ea shall occur within 10 seconds and maintain 7.1 percent concentration by volume at 70 degrees Fahrenheit for 10-minute holding time in hazard areas. HFC 227ea concentration in hazard areas greater than 9.0 percent immediately after discharge or less than 5.8 percent throughout holding time will not be accepted without written authorization from Owner and authorities having jurisdiction.

- b. Minimum calculated working pressure shall be 620-psig and 360-psig for an initial charging pressure.
4. Inergen (IG-541)
 - a. Discharge IG-541 within 60 seconds and maintain 38 percent concentration by volume at 70 degrees Fahrenheit for 10-minute holding time in hazard areas.
 - b. IG-541 concentration in hazard areas greater than 40 percent immediately after discharge or less than 32 percent throughout holding time will not be accepted without written authorization from Owner and authorities having jurisdiction.
 - c. Minimum calculated working pressure shall be 2175-psig upstream from orifice union, 1000-psig downstream from orifice union, and 2175-psig for an initial charging pressure.

21 31 13 Electric Drive Centrifugal Fire Pumps

Design Standard

1. The use of horizontal split case fire pumps shall be used to achieve required design pressures for the proposed fire protection system.
2. Vertical in-line fire pumps shall be considered where small design flows are required.
3. A Fire pump test header shall be located such that it is not in proximity to the main entry of the building. In cases where this is not possible, the device shall be installed such that it is an unobtrusive location, in harmony with the aesthetic nature of the building entry.

Product Standard

1. In-Line Fire Pumps
Provide products by one of the following
 - a. A-C Fire Pump Systems; a business of ITT Industries
 - b. Corcoran Piping System Co.
 - c. Patterson Pump Company; a subsidiary of the Gorman-Rupp Company
 - d. Peerless Pump, Inc.
 - e. Pentair Pump Group; Aurora Pump
 - f. Pentair Pump Group; Fairbanks Morse
 - g. Plad Equipment, Ltd.
 - h. Reddy-Buffaloes Pump Company
 - i. S.A. Armstrong Limited
2. Horizontally Mounted, Single Stage, Split-Case Fire Pumps
Provide products by one of the following
 - a. A-C Fire Pump Systems; a business of ITT Industries
 - b. Corcoran Piping System Co.
 - c. Patterson Pump Company; a subsidiary of the Gorman-Rupp Company
 - d. PACO Pumps; Grundfos Pumps Corporation, U.S.A.

- e. Peerless Pump, Inc.
 - f. Pentair Pump Group; Aurora Pump
 - g. Reddy-Buffaloes Pump Company
 - h. Ruhrpumpen, Inc.
 - i. S.A. Armstrong Limited
3. Vertically Mounted, Single Stage, Split-Case Fire Pumps
Provide products by one of the following
- a. A-C Fire Pump Systems; a business of ITT Industries
 - b. Patterson Pump Company; a subsidiary of the Gorman-Rupp Company
 - c. Peerless Pump, Inc.
 - d. Pentair Pump Group; Aurora Pump
 - e. Reddy-Buffaloes Pump Company
4. Relief Valves
Provide products by one of the following
- a. BERMAD Control Valves
 - b. CLA-VAL Automatic Control Valves
 - c. Kunkle Valve; a part of Tyco International Ltd.
 - d. OCV Control Valves
 - e. Watts Regulator Company; a division of Watts Water Technologies, Inc.
 - f. Zurn Plumbing Products Group; Wilkins Water Control Products
5. Flowmeter Systems
Provide products by one of the following
- a. Emerson Process Management; Rosemount Division.
 - b. Fire Research Corp.
 - c. Gerand Engineering Co.
 - d. Hydro Flow Products, Inc.
 - e. Hyspan Precision Products, Inc.
 - f. Meriam Process Technologies
 - g. Preso Meters; Division of Racine Federated Inc.
 - h. Reddy-Buffaloes Pump Company
 - i. Victaulic Company

Performance Standards

1. Fire pumps shall be selected to supply a design flow in the range of operation from 90% to 150% of its rated capacity.

21 34 00 Pressure Maintenance Pumps**Design Standards**

1. Pressure maintenance pumps shall be provided for every fire pump system to maintain the fire protection system pressure and minimize fire pump operation due to water supply leakage from underground piping systems.

Product Standards

1. Multistage, Pressure-Maintenance Pumps
Provide product by one of the following
 - a. A-C Fire Pump Systems; a business of ITT Industries
 - b. Grundfos Management A/S; Grundfos Pumps Corporation U.S.A.
 - c. PACO Pumps; Grundfos Pumps Corporation U.S.A.
 - d. TACO Incorporated

Performance Standards

1. Pressure maintenance pumps shall be selected to supply one percent of the fire pump rated capacity and have a pressure rating that is 10 psig greater than the pressure rating of the fire pump system.

21 39 00 Controllers for Fire Pump Drivers**Design Standards**

1. Controllers shall be of the across-the-line method of starting or of the reduced voltage starting utilizing the following methods
 - a. Primary Reactor
 - b. Primary Resistance
 - c. Autotransformer
 - d. Solid State Soft Start/Stop
2. Controllers shall be installed within sight of their respective drivers. Units located indoors shall be provided with a NEMA 12 rated dust tight, drip tight enclosure. Units located outdoors shall be provided with a NEMA 4 rated water tight enclosure.
3. Controllers for pressure maintenance pumps shall be provided with pump running and power available/failure contacts.

Product Standards

1. Full-Service Controllers
Provide products by one of the following:
 - a. Aquarius Fluid Products, Inc.
 - b. ASCO Power Technologies, LP; Firetrol Products
 - c. Eaton Electrical Inc.; Cutler-Hammer Business Unit
 - d. Hubbell Incorporated; Hubbell Industrial Controls
 - e. Joslyn Clark Corporation
 - f. Master Control Systems, Inc.
 - g. Metron, Inc.
 - h. Tornatech

2. Pressure-Maintenance-Pump Controllers
Provide products by one of the following:
 - a. Aquarius Fluid Products, Inc.
 - b. ASCO Power Technologies, LP; Firetrol Products
 - c. Eaton Electrical Inc.; Cutler-Hammer Business Unit
 - d. Hubbell Incorporated; Hubbell Industrial Controls
 - e. Joslyn Clark Corporation
 - f. Master Control Systems, Inc.
 - g. Metron, Inc.
 - h. Tornatech

Performance Standards

1. Provide controllers with a withstand rating of 200,000 Amperes at 480 Volts or less and 100,000 Amperes at 600 Volts.

DIVISION 22 PLUMBING

This chapter identifies criteria for the Plumbing Systems design for the University of Miami (UM) Buildings, with the purpose of establishing minimum standards, acceptable to UM, to be used as the basis of design for UM Coral Gables Campus.

- 22.1 General Requirements
 - 22.1.1 General Plumbing Requirements
 - 22.1.2 Submittals
- 22.2 Codes and Standards
 - 22.2.1 Plumbing Design Standards
 - 22.2.2 Cold Water Flow Rates
- 22.3 Plumbing Design Criteria
 - 22.3.1 Performance Standards
 - 22.3.2 Products Standards
- 22.4 Utility Coordination
- 22.5 Mechanical Rooms (for plumbing equipment)
- 22.6 Specific Plumbing requirements
(Organized by CSI MasterFormat® 2012 Numbers & Titles)

22.1 General Requirements

All work shall be designed by a Professional Engineer licensed in the State of Florida.

Before the start of construction on new buildings and/or major renovations, the Contractor shall provide a drawing for each building floor level showing the coordination of all structural, architectural and MEP items. This includes, but is not limited to: Structural members, floor plates, architectural ceilings, soffits, smoke barriers, fire walls, vertical shafts, sleeves, fire dampers, HVAC ductwork and equipment, plumbing piping and equipment, fire protection piping and equipment, alarm systems, communications, electrical distribution and equipment, lighting, controls, BMS, lighting protection, security systems, etc.

UM buildings plumbing systems must be designed to comply with the following objectives:

1. Sustainable Design, reducing total building energy and water consumptions.
2. Flexibility to allow for major and minor alterations which will occur during the typical building's life span, without causing major disruptions to other areas of the building.
3. High level of integration between architecture and the engineering systems using the latest advancements in technology.
4. User's comfort.
5. Ease of maintenance.
6. Solutions with the best value considering a life cycle cost analysis to account for the total project cost.

The design of the plumbing systems, in concert with other building components, shall produce a building that meets the programmed sustainability rating (LEED rating) of the specific project.

22.1.1 General Plumbing Requirements

Plumbing drawings shall include floor plans and isometric drawings for the following systems to the extent of 5 feet beyond the building perimeter:

1. Domestic water
2. Sanitary building drainage
3. Storm drainage
4. Liquefied petroleum gases (LPG) or compressed natural gas (CNG)
5. Fuel oil
6. Acid resistant piping and dilution tank
7. HVAC condensate piping
8. Boilers and domestic hot water generators including boilers necessary for space heating
9. Heating and domestic water heat exchangers and storage tanks
10. Compressed air, excluding HVAC controls
11. Steam and condensate return
12. Solar energy
13. Miscellaneous piping
14. Rainwater collection

22.1.1 Submittals

Submittals shall include product data, samples, and shop drawings which are coordinated with all corresponding disciplines. The Design Professional must ensure that all submittals and shop drawings are coordinated with other disciplines. In addition, provide the following:

1. Submittals shall include coordinated shop drawings including all systems using same spaces.
2. Provide written specifications indicating type of fixtures and manufacturers, including submittal of data sheets of fixtures and warranties.
3. Provide a set of prints and clearly mark, as the job progresses, including all changes and deviations from that shown on Contract Drawings. Drawings shall be kept up-to-date during construction and in addition to field measurements shall include; change orders, field instructions and all other changes.

22.2 Codes and Standards

The Plumbing design shall comply with the requirements of the applicable authorities having jurisdiction, and with the in-force edition at the time of the project of the following codes and standards:

22.2.1 Plumbing Design Standards

1. Florida Building Code, (FBC).
2. National Fire Protection Association (NFPA).
3. City of Coral Gables, Local Codes and Ordinances
4. American with Disabilities Act (ADA)
5. American Society of Plumbing Engineers Standards (ASPE)

22.2.2 Cold Water Flow Rates

1. Water closets: 1.28 GPF maximum
2. Urinals: 0.125 GPF maximum
3. Lavatories: 0.5 GPM maximum
4. Showers: 2.0 GPM maximum

22.3 Design Criteria

1. Gas lines shall not be installed in student residential areas.
2. Shut-off valves for all systems, cold water, hot water, etc. shall be tagged and numbered.
3. Location of any valve or other component above a suspended ceiling shall include a location marker permanently attached to the ceiling grid system.
4. All permanently installed equipment or appliance shall be of industrial quality. Warranty for such equipment shall be reviewed and approved by the UMBS Committee.
5. Hose bibbs are not required in bathrooms where janitor closets are located nearby. All floor drains shall have non-mechanical priming systems.
6. Hose bibbs or hose connections shall be protected with a vacuum breaker to prevent backflow.
7. Exterior hose bibbs shall be recessed wall hydrants, loose keyed, flanged, chrome plated, independently valved, vacuum breaker equipped, and at the building perimeter or courtyards at intervals not to exceed 150 feet.
8. Each restroom shall be equipped with a main shut off valve, located for easy access and maintenance.
9. Concrete housekeeping pads shall be provided for all floor mounted pumps, water heaters, etc. and shall be 4 inches high minimum.

10. A piping and valve chart/legend shall be provided by the contractor at the end of construction. A copy of this chart shall be affixed in a visible place inside the mechanical room.
11. Provide cleanouts at end of laterals serving water closets.
12. Provide clean outs at all changes of direction 90° and higher, at bottom of all vertical risers and on horizontal lines at intervals not to exceed 100 feet.
13. Provide cleanouts at vertical risers serving urinals.
14. All shut off valves and cleanouts serving toilets should have access panels.
15. All toilet rooms having more than two fixtures should have floor drains and hose bibbs.
16. All floor drains in toilet rooms shall have trap re-sealers attached to flush valve tailpieces. All other floor drains shall be resealed using mechanical trap re-sealers. Show location of resource on plans.
17. All fixtures should have support carriers.
18. Water closets at public toilets shall be wall mounted unless existing conditions require floor mounted toilets. All other water closets shall be as deemed appropriate for the specific condition and function intended.
19. Faucets at the lavatories shall be of the solar powered and wireless type: Sloan Solis EAF-275-15M.
20. Water coolers shall be all stainless steel finish, all sides.
21. Minimum chase and wall requirements for plumbing fixtures:
 - a. Water closets: Wall hung horizontal carrier, back to back. Clear space between chase walls shall be not less than 24 inches.
 - b. Water closets: Wall hung horizontal carrier. Single clear space between chase walls or rough thick single wall shall be not less than 14 inches.
 - c. Wall for other types of fixtures shall not be less than 6 inches thick.
 - d. Installation of all fixtures shall be in accordance with all applicable codes, including ADA where required.
 - e. Locate pipe chases clear of structural elements.
 - f. Fixtures in common chase shall be installed back to back or aligned to facilitate installation.
22. Provide a dousing shower and eyewash for emergency use at water treatment areas for chillers and other areas according to OSHA.

23. Locate an exterior master shut-off valve underground in a lockable valve box near each building served.
24. Elevated water storage tanks are prohibited.
25. Provide domestic water pressure booster systems where street pressure is insufficient to maintain required water pressure levels.
26. Flush valves at gang water closets shall be solar powered, wireless type: Sloan RESS-C 1.6/1.1 GPF.
27. Flush valves at gang urinals shall be solar powered, wireless type: Sloan RESS-U 0.125. GPF
28. University of Miami Plumbing Requirements for “Gender Inclusive” Bathroom Standards.
 - a) All new construction and major renovations shall provide a separate, private restroom with a lock that would meet multiple needs of any gender that complies with the requirements listed under the Florida Building Code 5th Edition (2014) for fixtures. These types of restrooms should be identified as inclusive facilities. All design shall be reviewed and approved by Facilities Management Design & Construction Department.
 - b) Inclusive restrooms shall comply with the requirements of the Florida Building Code 6th Edition (2017) Accessibility Code and ADAAD requirements issued by the Department of Justice and Department of Transportation under the “American Disabilities Act”.
 - c) Signage requirements and standards are per Facilities Management Design & Construction for use by the design professional for incorporation into the design.
 - d) Baby diaper changing stations shall be provided in all inclusive restrooms, in compliance with “The Baby Diaper-Changing Accommodations Ordinance (Section 8A-114) of the Miami-Dade County Code).
 - e) The preferred location of inclusive restrooms shall be near the building main entrance / lobby areas on the ground floor.
 - f) Inclusive restrooms shall contain accommodations for an automatic door opener in the design.

22.3.1 Performance Standards

1. The plumbing systems shall be designed to comply with the Florida Building Code’s energy and the performance goals.
2. Factory performance testing and start-up services will be required for large system components like boiler plants, domestic water heaters, and laboratory equipment and booster pump systems.

3. The contractor shall provide certified test reports confirming required performance to the Facilities Management of the University.
4. Booster pumping equipment:
 - a. Provide a domestic water pump pressure booster system only if available street pressure is insufficient to serve the plumbing fixture requirements.
 - b. Variable flow pressure booster systems shall be provided completely assembled and wired.
 - c. For applications with less than 100 pounds per square inch (psi) boost, and flow (as sized by Hunter's curve) of 300 gallons per minute (gpm) or less, specify a duplex close-coupled end-suction booster with variable frequency drive (VFD) controls and a remote mounted 100 to 200 gallon tank. Each pump should be sized for 50 percent capacity minimum, and trim the impeller to horsepower.
 - d. For higher flows but still less than 100-psi boost, specify triplex or quadruplex end suction boosters with no more than 300 gpm per pump. For example, a 400-gpm booster should be a triplex with a minimum 133 gpm per pump. A 1,000-gpm booster should be a quadruplex with 250 gpm per pump.
5. Equipment nameplates: Metal nameplates permanently fastened to equipment and having data engraved or stamped.
6. Piping System: Install pipe markers on each system. Include arrows showing normal direction of flow.

22.3.2 Products Standards

1. Piping:
 - a. Sanitary waste and storm drainage: (Below Ground) Six stories or less:
 - 1) Service weight cast iron hub and spigot with neoprene gaskets or PVC Piping Sch 40 to a point 5'-0" outside of building.
 - b. Sanitary waste and storm drainage; (Above Ground) service weight hub-less cast iron with stainless steel and neoprene seals.
 - c. Domestic water:
 - 1) Above ground: copper type "L"
 - 2) Below ground: 3" and smaller copper type "K"
 - 3) Below ground – 4" and larger ductile iron.
2. Valves:
 - a. Brass body gate or ball valves with full post opening in copper pipe.
 - b. Semi-steel or cast iron body valves for ferrous metal pipe only.
3. Plumbing Fixtures
Appendix to Section 224000

4. Water Closets:
 - a. Wall Hung Water Closet:
 - 1) White vitreous china, top spud, siphon jet flush action, 1.1 gpf maximum, elongated bowl.
Afwall by American Standard.
Zurn 25615.
Toto or approved equal.
 - 2) Flush Valve: Sloan Solis RESS-C-1.6/1.1 dual flush 1.1 gpf
 - 3) Seat: Elongated, open front less cover.
 - (1.) 95 by Olsonite.
 - (2.) Lustra K-4670-C by Kohler.
 - (3.) 50ESS by Sperzel.
 - (4.) SC514 by Toto.
 - b. Wall Hung Water Closet, HC Accessible (for replacement at existing conditions with non ADA carrier):
 - 1) White vitreous china, top spud, siphon jet flush action, 1.1 gpf, and elongated bowl.
 - (1.) Afwall by American Standard.
 - 2) Flush Valve: Sloan Solis RESS-C-1.6/1.1 dual flush 1.1 gpf
 - 3) Seat: Elongated, open front less cover.
 - (1.) 95 by Olsonite.
 - (2.) 9500C by Church.
 - (3.) 50ESS by Sperzel.
 - (4.) SC514 by Toto.
 - c. Floor Mounted Water Closet:
 - 1) White vitreous china, top spud, siphon jet flush action, 1.1 gpf and elongated bowl.
 - (1.) Madera 1.1 gpf by American Standard.
 - (2.) Zurn, back outlet, Z5635-BWL.
 - (3.) or approved equivalent.
 - 2) Bolt Caps: by American Standard or accepted equivalent.
 - 3) Flush Valve: Sloan Solis RESS-C-1.6/1.1 dual flush 1.1 gpf
 - 4) Seat: Elongated, open front less cover.
 - (1.) 95 by Olsonite.
 - (2.) Lustra K-4670-C by Kohler.
 - (3.) 50ESS by Sperzel.
 - (4.) SC514 by Toto.
 - 5) Seat, HC Accessible: 3" or 4-5/8" high seat lift, elongated, closed front, hollow core heavy duty plastic, vinyl coated offset mounting bracket by Bemis or accepted equivalent.
 - d. Floor Mounted Water Closet, HC Accessible:
 - 1) White vitreous china, top spud, siphon jet flush action 1.1 gpf, and elongated bowl.

- (1.) Madera 17 inches high, 12 inches rough – by American Standard.
 - (2.) Zurn, back outlet, Z5635-BWL.
 - (3.) or approved equivalent.
 - 2) Bolt Caps: by American Standard or accepted equivalent.
 - 3) Flush Valve: Sloan Solis RESS-C-1.6/1.1 dual flush 1.1 gpf
5. Urinal:
 - a) Siphon Jet Flush Action: Wall hung, 0.125 gpf max. vitreous china, $\frac{3}{4}$ " top inlet spud.
 - 1) Allbrook 6550.501.020 by American Standard.
 - 2) Dexter K5016-T by Kohler.
 - b) Optional Blowout Flush Action, Wall hung, 1 $\frac{1}{4}$ " top inlet spud
 - 1) Lynbrook 0.85 6601.012 by American Standard
 - 2) Stainwell K 4972-et T by Kohler.
 - c) Flush Valve: Sloan RESS-U, 0.125 GPF
 - d) Flush valve for optional blowout flush action: Sloan RESS-U, 1.0 GPF
6. Service Sink:
 - a) Enameled cast iron, 22 inches x 18 inches, plain back, rim guard.
 - 1) Lakewell 7692.008 by American Standard.
 - 2) Bannon K-6719 by Kohler.
 - b) Fitting: Exposed yoke, wall mounted, vacuum breaker, top brace, stops in shanks.
 - 1) 8350.243 by American Standard
 - 2) Knoxford K-8906-RP by Kohler.
 - c) "P" Trap: Strainer, outlet to wall.
 - 1) 7798.020 by American Standard.
 - 2) K-6673 by Kohler.
7. Mop Receptor:
 - a) Molded resin, 24 inches x 24 inches x 10 inches, rim guards, center drain.
 - 1) Model MSR-2424 by Florestone.
 - 2) Model MSB-2424 by Fiat.
 - b) Fitting: Exposed yoke, wall mounted, vacuum breaker, top brace, stops in shanks.
 - 1) Heritage 8354.112 by American Standard.
 - 2) Kinlock K-8907by Kohler.
 - 3) 8350.243 by American Standard
 - 4) 897-RCF by Chicago Faucets.
 - 5) Pro Flo PF118 by Kohler

- 6) Knoxford K8905
 - c) Drain assembly: Acorn Drain Gasket KDG2 and drain, or accepted equal.
8. Lavatories:
- a) Wall Hung (HC Lav):
 - 1) Vitreous China, 20 inches x 18 inches, 3 hole, 4 inch centers, with lug holes for concealed carrier arms.
 - (1.) Roxalyn 0195.073 by American Standard.
 - (2.) Chesapeake K-1729 by Kohler.
 - (3.) Accepted equivalent.
 - 2) Use electronic sensor type faucets at public toilets: Sloan Solis Systems, Solar Powered EAF-275 OR eaf-275 15M
 - 3) Cold Water Fitting, accessible: Single lavatory fitting, self closing metering, adjustable time cycle, push handle, vandal resistant aerator.
 - (1.) 1340M.105 by American Standard.
 - (2.) 333-669 by Chicago Faucets
 - (3.) K-7504 by Kohler.
 - 4) Hot and Cold Water Fitting, accessible: 4 inch centers, 4 inch spout, 2- 2 ½" lever Handles, 1.5 gpm flow maximum, vandal resistant aerator.
 - (1.) 5502.140 by American Standard.
 - (2.) 802-317ABPC by Chicago Faucets.
 - (3.) K-7404-K/K-16010-4 by Kohler
 - 5) Hot Water Guard:
 - (1.) White, Handi-Lav-Guard Insulation Kit 102/105 by Truebro.
 - (2.) White, Handi-Shield Original Series by Plumberex, Palm Springs, CA.
 - (3.) Use manufacturer's vandal resistant fasteners.
 - 6) Supply Pipe: 3/8" rigid riser with loose key control. By McGuire or accepted equivalent.
 - 7) "P" Trap: Adjustable offset with tubing drain to wall, cleanout plug and wall escutcheon. By McGuire or accepted equivalent.
 - 8) Floor Mounted Carrier Arms: Josam 17100-M-628 or accepted equivalent.
 - b) Countertop Mounted Lav (HC Lav):
 - 1) Solid surface, 20 inches x 17 inches, integrally molded bowl, 4 inch centers.
 - (1.) Aqualyn 0476.028 by American Standard
 - (2.) Pennington K-2196 by Kohler
 - 2) Use electronic sensor type faucets at public toilets: Sloan Solis Systems, Wireless EAF-275 OR EAF-275 15
 - 3) Cold Water Fitting: Single lavatory fitting, self closing metering, adjustable time cycle, push hand, vandal resistant aerator.

- (1.) 1340.105 by American Standard
 - (2.) 333-669 by Chicago Faucets
 - (3.) K-7504-C by Kohler.
 - 4) Hot and Cold Water Fitting: 4 inch centers, 4 inch spout, 2- 2 ½” lever handles, 1.5 gpm flow, vandal resistant aerator.
 - (1.) 5502.140 by American Standard
 - (2.) 802-317ABPC by Chicago Faucets
 - (3.) K-7404-K/K-16010-4 by Kohler.
 - 5) Supply Pipe: 3/8” rigid riser with loose key control. By McGuire or accepted equivalent.
 - 6) “P” Trap: Adjustable with tubing drain to wall, cleanout plug and wall escutcheon. By McGuire or accepted equivalent.
 - 7) Hot Water Guard: White, Handi Lav-Guard Insulation Kit 102/105 by Truebro.
 - 8) Grid drain: Perforated, chrome plated, 1- ¼” tailpiece. By McGuire or accepted equivalent.
9. Sinks:
- a) Double Compartment Stainless Steel Sink:
 - 1) 33 inches x 22 inches, 8 inches deep, 18 gage, Type 302 stainless steel, self-rimming.
 - (1.) LR-3322 by Elkay
 - (2.) Accepted equivalent
 - 2) Cold Water Fitting: Gooseneck faucet, single hole inlet, 8 inch swing spout, vandal resistant aerator, 2- ½” lever handle.
 - (1.) 350-GN8A-E12VP-369 by Chicago Faucets.
 - (2.) Accepted equivalent
 - 3) Hot and Cold Water Fitting: Gooseneck faucet, 8 inch centers, 8 inch spout, vandal resistant aerator, 2- ½” lever handles.
 - (1.) 7420.801 by American Standard
 - (2.) 895-317GN8AE35 ABCP by Chicago Faucets or accepted equivalent.
 - b) Single Compartment Stainless Steel Sinks:
 - 1) Type 302 stainless steel, 18 gage, self-rimming.
 - 2) Sizes and model numbers by Elkay or accepted equivalent:

Length x Width (inches)	Depth (inches)	Model #
(SK-1) 25 x 22	8.0	LR-2522
(SK-2) 31 x 22	7.5	LR-3122
(SK-3) 17 x 22	10.0	DLR-1722-10
(SK-4) 22 x 22	10.0	DLR-2222-10
(SK-5) 25 x 22	10.0	DLR-2522-10
(SK-6) 31 x 22	11.5	DLR-3122-12

- 3) Cold Water Fitting: Gooseneck faucet, single hotel inlet, 5- 3/8" spout, 2- 1/2" lever handle, vandal resistant aerator.
 - (1.) 7100-271H.002 by American Standard
 - (2.) 895-317GN2AFCABCP by Chicago Faucets
 - (3.) Bardney K-7895 by Kohler
 - 4) Hot and cold Water Fitting: Gooseneck faucet, single hole inlet, 5- 3/8" spout, 2- 1/2" lever handles, vandal resistant aerator.
 - (1.) 443.420.075 by American Standard
 - (2.) 895-317GN2AFCABCP by Chicago Faucets
 - (3.) Triton K-7305-KE by Kohler.
 - 5) Supply Pipes: Flexible risers and loose key controls. 2303.063 by American Standard.
 - 6) "P" Trap: Adjustable with tubing drain to wall, cleanout plug and wall escutcheon: K-8998 or K-8999 by Kohler or accepted equivalent.
 - 7) Grid Drain: Perforated with 1- 1/2" diameter tailpiece: LK18 by Elkay or accepted equivalent.
- c) Wash Sink:
- 1) Type 304 Stainless Steel, 14 gauge, 64 inches x 18 inches, drilled back
 - (1.) S96-080 by Bradley, or equal.
 - (2.) S93-649 Semi-circular 'Washfountain' by Bradley, or equal.
 - 2) Fitting: Exposed yoke, wall mounted, and vacuum breaker, stops in shanks
 - (1.) Chicago 1100-317ABCP
 - (2.) ZURN Z871G4-XL
 - 3) Solids Interceptor: Gasketed cover, stainless steel screens: 61040A by Josam or accepted equivalent. Josam clay or plaster interceptor Model 61030 under sink.
10. Electric Water Coolers:
- a) Wall mounted, 2 stream mound building projector, self-closing valve with automatic stream regulator, polished chrome plated brass bubbler, push bars in front and on both sides, for handicapped and standard use. All stainless steel body.
 - 1) Halsey Taylor: Model HAC8FS
 - 2) Haws: Model H1011.8 'Hi-Lo' or H1107.8
 - 3) Oasis: Model P8AC

- b) No lead shall be allowed in the manufacture of any piece of equipment within the water coolers, nor in any piping joint or connection within the unit.
- c) Provide dual units when required for accessibility compliance.

22.4 Utility Coordination

1. Sanitary, domestic, storm and gas load calculations shall be provided to the civil engineer; as well as plumbing systems required and proposed location for such utilities.
2. Location of utilities serving the plumbing systems and any other equipment must be coordinated with the architect and civil engineer to avoid conflicts and must consider all owner and local requirements, specifically clearance and accessibility.

22.5 Mechanical Rooms (for plumbing equipment)

1. Mechanical rooms shall be lockable and accessible only to qualified persons; and not accessible to professors, students or used for storage.
2. Mechanical rooms shall be sized to accommodate all the plumbing equipment to be installed. Provide the minimum size required to accommodate all necessary equipment in accordance with the Codes and for easy maintenance access. The door to mechanical room doors shall swing out.
3. When choosing the location for the mechanical room, consider the noise, heat output, ventilation requirements, power requirements, drainage, water and fuel.
4. Provide sufficient access to the room to allow for the replacement of the largest piece of equipment.
5. Within the mechanical room, provide 40% additional space for future equipment.
6. Locate mechanical rooms so that they are clear of columns, beams, shear walls, stairways, duct shafts, elevators and other obstructions to permit a clear running of the plumbing lines to assigned spaces.
7. Rooms shall be sprinklered, and located in fully sprinklered facilities.
8. Provide and attach mechanical equipment to 4 inch high minimum housekeeping concrete pad. Extend pad at least 6 inches beyond the equipment's outline. Vibration isolation may be required for larger pads.

**22.6 Specific Plumbing Requirements
(Organized by CSI MasterFormat® 2012 Numbers & Titles)**

22 05 16	Expansion Fittings and Loops for Plumbing Piping
22 05 17	Sleeves and Sleeves Seals for Plumbing Piping
22 05 19	Meters and Gages for Plumbing Piping
22 05 23	General Duty Valves for Plumbing Piping
22 05 29	Hangers and Supports for Plumbing Piping and Equipment
22 05 53	Identification for Plumbing Piping and Equipment
22 07 16	Plumbing Equipment Insulation
22 07 19	Plumbing Piping Insulation
22 11 16	Domestic Water Piping
22 11 23	Domestic Water Pumps
22 13 16	Sanitary Waste and Vent Piping
22 13 23	Sanitary Waste Interceptors
22 14 29	Sump Pumps
22 15 13	General Service Compressed Air Piping
22 15 19	General Service Packaged Air Compressors and Receivers
22 33 00	Electric Domestic Water Heaters
22 34 00	Fuel Fired Domestic Water Heaters
22 40 00	Plumbing Fixtures
22 45 00	Emergency Plumbing Fixtures
22 47 13	Drinking Fountains and Remote Water Coolers

22 05 16 Expansion Fittings and Loops for Plumbing Piping

Design Standards:

1. All connections and changes in direction of the sanitary drainage system shall be made with approved drainage fittings.

Product Standards:

1. Preferred manufacturers: Mueller, Nibco, Elkhart or Propress.

Performance Standards:

1. Compatibility: Products shall be suitable for piping service fluids, materials, working pressures, and temperatures.
2. Capability: Products to absorb 200 percent of maximum axial movement between anchors.

22 05 17 Sleeves and Sleeve Seals for Plumbing Piping**Design Standards:**

1. Annular spaces between sleeves and pipes shall be filled or tightly caulked in an approved manner. Annular spaces between sleeves and pipes in fire-resistance-rated assemblies shall be filled or tightly caulked in accordance with the Code requirements. Any pipe that passes under a footing or through a foundation wall shall be provided with a relieving arch, or a pipe sleeve that shall be built into the foundation wall. The sleeve shall be two pipe sizes greater than the pipe passing through the wall.

Product Standards:

1. Preferred manufacturers: Advance Products and Systems, Inc, Zurn or Pipeline Seal and Insulator, Inc.

22 05 19 Meters and Gages for Plumbing Piping**Design Standards:**

1. Provide sub-metering connected to EMS at points of building service.
2. Provide pressure gauge fittings at top floor of facilities.

Product Standards:

1. Preferred manufacturer for Test-Plug Kits: Nibco.
2. Preferred manufacturer for Thermometers: Watts Regulators Co or Weiss Instruments, Inc.

Performance Standards:

1. Water meter selection shall be based on a 5 to 8 psig pressure drop at peak design flows and not maximum capacity, regardless of pressure drop.

2. For LEED projects, the OPR will indicate the BMS system to monitor the sub-metering of energy consuming equipment. This relates also to EAC 5 Measurement and Verification.

22 05 23 General Duty Valves for Plumbing Piping

Design Standards:

1. Provide high quality ball valves and fittings.
2. Provide isolation valves on each floor and bathrooms with ID tags.
3. Provide isolation valves at all branch take-offs from main distribution line.
4. Preferred ball valves: full port
5. Provide a valve location plan at the equipment room, showing what they control.
6. Install valves with unions or flanges at each piece of equipment arranged to allow service, maintenance, and equipment removal without system shutdown.
7. Equipment or hose bibbs typically not receiving service stops shall be provided with valves.
8. All valves shall be accessible.
9. Locate valves for easy access and provide separate support where necessary.

Product Standards:

1. Preferred manufacturers:
 - a. Mueller
 - b. Nibco
 - c. Elkhart
 - d. Propress.

22 05 29 Hangers and Supports for Plumbing Piping and Equipment

Design Standards:

1. Provide non corroding materials only.
2. Base the spacing of hangers on the strength and modulus of elasticity of each piping material.

3. Provide rigid support sway bracing when the pipes are 4" or larger and the change in direction is greater than 45 degrees.
4. Anchor pipe as to restrain drainage piping from axial movement.
5. Piping shall be isolated from incompatible materials.

Product Standards:

1. Preferred manufacturers:
 - a. Allied Tube & Conduit.
 - b. Flex-Strut Inc.
 - c. GS Metals Corp.
 - d. Thomas & Betts Corporation.
 - e. Unistrut Corporation; Tyco International, Ltd.

Performance Standards:

1. Structural Performance: Plumbing piping and equipment hangers and supports shall withstand the effects of gravity loads and stresses within limits and under working conditions and not be detrimental to the pipe they support.

22 05 53 Identification for Plumbing Piping and Equipment

Design Standards:

1. Label all piping per industry standards at equipment room and 10' o.c. thereafter.
2. Provide ID tags at all valves and plumbing equipment.

Product Standards:

1. Provide metal labels for equipment.
2. Stencil material and paint for piping.
3. Provide aluminum Tags for valves.

Performance Standards:

1. Piping and equipment shall be labeled as per current industry standards.

22 07 16 Plumbing Equipment Insulation**Design Standards:**

1. Provide insulation for the unfired hot water storage tanks to conserve energy.
2. Protect the insulation against physical damage by adding a strong jacket or delaying installation of the insulation on the piping system.
3. When installing insulation in a corrosive environment, select the proper jacket which will withstand the most severe conditions.
4. Select the proper insulation to fit in confined spaces.

Product Standards:

1. Preferred manufacturers:
 - a. CertainTeed Corp.; Duct Wrap.
 - b. Knauf Insulation; Duct Wrap.
 - c. Manson Insulation Inc.; Alley Wrap.
 - d. Owens Corning; All-Service Duct Wrap.

Performance Standards:

1. Install equipment insulation to achieve the following:
 - a. Reduction of heat or cooling temperature loss through the piping.
 - b. Elimination of condensation.
 - c. Personnel protection by keeping the surface temperature low enough to touch.
 - d. Protection of equipment from abrasion or damage from external forces.

22 07 19 Plumbing Piping Insulation**Design Standards:**

1. Provide fiberglass insulation for all hot water lines.
2. Provide foam rubber insulation for all condensate piping.
3. Provide fiberglass insulation for all horizontal roof drain lines above ceilings.
4. Protect the piping system's insulation against physical damage.
5. When installing insulation in a corrosive environment, select the proper jacket which will withstand the most severe conditions.

6. Select the proper insulation to fit in confined spaces.

Product Standards:

1. CertainTeed Corp.; Duct Wrap.
2. Knauf Insulation; Duct Wrap.
3. Manson Insulation Inc.; Alley Wrap.
4. Owens Corning; All-Service Duct Wrap.

Performance Standards:

1. Install equipment insulation to achieve the following:
 - a. Reduction of heat or cooling temperature loss through the piping.
 - b. Elimination of condensation.
 - c. Personnel protection by keeping the surface temperature low enough to touch.
 - d. Protection of equipment from abrasion or damage from external forces.
 - e. Consider the appearance of the pipe, where aesthetics are important.
 - f. Reduction of noise from the piping system.

22 11 16 Domestic Water Piping**Design Standards:**

1. The use of PVC or CPVC in domestic water distribution is prohibited.
2. Gate valves are not allowed in the domestic water system.
3. Flow velocity shall not be greater than 8 feet per second.
4. Control the flow velocity of the water distribution system to reduce the possibility of water hammer.
5. Provide water hammer arrestors at all fixture groups.
6. Emergency water supply shall have a locked and labeled valve at fixture branch feed line. There shall not be any additional valves or stops downstream of the locked and labeled valve.

Product Standards:

1. Domestic water:
 - a. Above ground: copper type “L”
 - b. Below ground: 3” and smaller copper type “K”
 - c. Below ground – 4” and larger ductile iron.

Performance Standards:

1. The primary goal of the building cold water service and distribution system is to provide adequate flow, pressure and volume suitable for human consumption at every device that uses water, even when the system is at peak demand.
2. All hot water distribution pipe and tubing shall have a minimum pressure rating of 100 psi at 180 degrees or as required to meet building static head.
3. The piping system, components and fixtures in a water distribution system shall be designed to withstand a minimum working pressure of pressure of 80 psi or as required to meet building static head.
4. Prior to disinfection, connection to faucets and equipment, and installation of pipe insulation, the domestic water system should be hydrostatically tested for leakage.

22 11 23 Domestic Water Pumps**Design Standards:**

1. Where the water pressure in the public water main is insufficient to supply the minimum pressure and quantities specified by code, the supply shall be supplemented by a water pressure booster system.
2. Provide water booster pumps on by-pass for use if primary system fails.
3. Provide pressure level alarms at all domestic water pumps.
4. Variable flow pressure booster systems shall be provided completely assembled and wired.
5. For applications with less than 100 pounds per square inch (psi) boost, and flow (as sized by Hunter's curve) of 300 gallons per minute (gpm) or less, specify a duplex close-coupled end-suction booster with variable frequency drive (VFD) controls and a remote mounted 100 to 200 gallon tank. Each pump should be sized for 50 percent capacity minimum, and trim the impeller to horsepower.

6. For higher flows but still less than 100-psi boost, specify triplex or quadruplex end suction boosters with no more than 300 gpm per pump. For example, a 400-gpm booster should be a triplex with a minimum 133 gpm per pump. A 1,000-gpm booster should be a quadruplex with 250 gpm per pump.

Product Standards:

1. Preferred manufacturers:
 - a. Grundfos
 - b. Bell & Gosset

Performance Standards:

1. High efficiency pumps shall be specified.

22 13 16 Sanitary Waste and Vent Piping**Design Standards:**

1. Every building in which plumbing fixtures are installed shall be connected to a public sewer, where available, or an approved sewage disposal in accordance with the current code and local ordinances.
2. Provide floor drains in all restrooms and janitor closets.
3. In addition to cleanouts requirements by the Florida Building Code, provide additional cleanouts on laterals that serve three or more fixtures in a less visible area.
4. Provide acid resistant piping system for science labs separate from sanitary waste and vent lines until neutralized. Provide acid neutralizing tank, to be located outside building, below grade. Continue acid waste piping beyond neutralization tank to a point where it is washed by minimum of two water closets.
5. The vent system for a chemical waste system shall be independent of the sanitary vent system and shall terminate separately through the roof to the open air.
6. Provide sanitary vent systems in locations where the use of passive venting is not possible. Where there are no connections to waste and vent chemical systems, air admittance valves may be used.

Product Standards:

1. Piping:
 - a. Sanitary waste and storm drainage: In buildings six stories or less (below ground):
 - 1) Service weight cast iron hub and spigot with neoprene gaskets or PVC Piping Sch 40 to a point 5'-0" outside of building.
 - b. Sanitary waste and storm drainage; (above ground)
 - 1) Service weight hub-less cast iron with stainless steel and neoprene seals.
 - c. Acid resistant piping shall be polypropylene with electro-fusion pipe joints.
2. Air admittance valves:
 - a. Studor Inventive Technology (Studor Vent).

Performance Standards:

1. Specify and install components which are capable of withstanding a minimum working pressure, of 10-foot head of water.

22 13 23 Sanitary Waste Interceptors**Design Standards:**

1. Interceptors and separators shall be provided to prevent the discharge of oil, grease, sand and other substances harmful or hazardous to the building drainage system, the public sewer, or sewage treatment plan or processes.
2. Locate interceptors as close as feasible to the exterior wall of the served area.
3. Waste lines normally receiving grease waste shall be routed through the interceptor.
4. Individual grease interceptor capacity shall be at least 750 gallons.
5. Maximum individual grease interceptor capacity shall not exceed 1,250 gallons.
6. Provide multiple 1,250 gallon capacity interceptors in series for required capacities above 1,250 gallons.

Product Standards:

1. Grease interceptors:
 - a. Precast concrete
2. Oil interceptor:
 - a. Precast concrete

- b. Factory fabricated, cast iron or steel body; with removable sediment bucket or strainer, baffles, vents and flow-control fitting on inlet.

Performance Standards:

1. The interceptors, as the name indicates, shall intercept substances that have been separated from the waste water, which is then discharged, leaving behind the separated material in the interceptor itself.

22 14 29 Sump Pumps**Design Standards:**

1. Where the drainage system or portions thereof cannot discharge by gravity to the sewer, the drainage shall be collected in a tightly sealed and vented sump and pumped to a gravity sewer or drain.
2. The sump must be sized to provide adequate holding capacity and to limit the retention period of the waste.
3. The minimum capacity of the sump must be such that the pumping equipment operates for at least 15 seconds per pumping cycle to prevent short cycling, thereby extending the life of the equipment.
4. A check valve and full open valve, located on the discharge side of the check valve, shall be installed in the pump or ejector discharge piping between the pump or ejector and the gravity drainage system.

Product Standards:

1. Preferred manufacturer:
 - a. Goulds

Performance Standards:

1. The sump pump capacity and head shall be appropriate to anticipate future use requirements.
3. Sump pit shall be not less than 18 inches in diameter and 24 inches in deep, unless otherwise approved.

22 15 13 General Service Compressed Air Piping**Design Standards:**

1. Automatic water traps with shut-off valves and piped drains shall be provided at the following locations:
 - a. Air lines exiting the air compressor.
 - b. Compressor storage tank.
 - c. First air riser from the compressor and risers over 1 story in height.
 - d. End of the main line branch.
 - e. Provide a petcock at the bottom of piping riser/drops without an automatic water trap, and at the bottom of each air outlet.
2. Provide 1 inch in 40 feet slope down in the airflow direction of air lines and avoid water collection pockets. Reverse slopes are not allowed. Air branch lines shall be taken from only the top of the main line.
3. In anticipation of expansion, consideration should be given to oversizing some components, such as filters, dryers, and main pipes, to avoid costly replacement in the future and to save downtime while expansion is underway.
4. Information about pressure and flow rate parameters for individual equipment and tools shall be obtained from the manufacturer, end user, facility planner, or owner.
5. Provide refrigerated after cooler at compressor discharge.

Performance Standards:

1. Compressed air system must be designed (controlled, regulated, and sized) to ensure that an adequate volume of air at a pressure and purity that will satisfy users requirements is delivered at any outlet, particularly the most hydraulically remote, during the period of heaviest use.

22 15 19 General Service Packaged Air Compressors and Receivers**Design Standards:**

1. Air compressors shall be located in a mechanical equipment room.
2. Compressors shall be tank mounted and sized to accommodate the diverse requirements.
3. Compressors 3HP and larger shall be two stage.
4. Receivers should be sized on the basis of system demand and compressor size, using the starts per hour and running time best suited for the project.

Product Standards:

1. Preferred manufacturer
 - a. Ingersoll-Rand; Air Solution Group.

Performance Standards:

1. Compressed air system must be designed (controlled, regulated, and sized) to ensure that an adequate volume of air at a pressure and purity that will satisfy users requirements is delivered at any outlet, particularly the most hydraulically remote, during the period of heaviest use

22 33 00 Electric, Domestic Water Heaters**Design Standards:**

1. Hot water of a desired temperature should be readily available at any fixture.
2. Domestic hot water shall be limited to 110 degrees F; temperature at food preparation areas per Health Authority requirements.
3. Tankless water heaters may be used at custodial sinks and remote fixture locations requiring hot water. Hot water shall be thermostatically controlled and shall not exceed 100 degrees F. Heater capacity shall be as per manufacturer's recommendation.
4. Provide domestic hot water hot water recirculation systems at kitchen and other high hot water demand systems where piping runs exceed 60 feet.
5. Minimum insulation thickness at domestic hot water mains shall be 1 inch thick.
6. Water heaters and storage tanks shall be located and connected so as to provide access for observation, maintenance, service and replacement.

Product Standards:

1. Preferred manufacturer:
 - a. Lochinvar Corporation.

4. A.O. Smith products shall not be used.

Performance Standards:

1. Domestic water heating system must be designed to ensure that an adequate volume of hot water at the prescribed temperature to all fixtures and equipment is delivered at all times at any outlet, particularly the most hydraulically remote, during the period of heaviest use.
2. The system shall perform its function safely.

22 34 00 Fuel Fired, Domestic Water Heaters**Design Standards:**

1. Hot water of a desired temperature should be readily available at any fixture.
2. Domestic hot water shall be limited to 110 degrees F.
3. Hot water at food preparation areas per Health Authority requirements.
4. Provide domestic hot water hot water recirculation systems at kitchen and other high hot water demand systems where piping runs exceed 60 feet.
5. Utilize high efficiency, closed combustion heaters when possible.
6. Minimum insulation thickness for domestic hot water mains shall be 1 inch thick.
7. Water heaters and storage tanks shall be located and connected so as to provide access for observation, maintenance, service and replacement.

Product Standards:

1. Preferred manufacturer:
 - a. PVI Industries, Inc.
 - b. Lochinvar Corporation.
2. A.O. Smith products shall not be used.

Performance Standards:

1. Domestic water heating system must be designed to ensure that an adequate volume of hot water at the prescribed temperature to all fixtures and equipment is delivered at all times at any outlet, particularly the most hydraulically remote, during the period of heaviest use.

22 40 00 Plumbing Fixtures**Design Standards:**

1. All fixtures and accessories to be "hands free operation. See section 22.3.2.
2. All fixtures sensors to be hard wired, unless otherwise noted.
3. Provide a janitor's closet (30 sq. ft. minimum) on each floor with a mop sink and floor drain
4. Waterless urinals use is prohibited.
5. No substitution allowed on preferred manufacturers.

Product Standards:

1. Lavatory faucets: See section 22.3.2-8.
2. New water closet flush valves: Sloan Optima. See section 22.3.2-4.
3. New urinal flush valves: See section 22.3.2-5.
4. Retrofit water closet flush valves: Sloan Optima, model # RESS-C-MC with courtesy flush override.
5. Retrofit urinal flush valves: Sloan Optima, model # RESS-U-MC with courtesy flush override.

Performance Standards:

See section 22.3.2.

22 45 00 Emergency Plumbing Fixtures**Design Standards:**

1. Water supplies for drench hoses, emergency showers and eyewashes shall be from an independent secure source not prone to inadvertent shutoff.

2. The emergency water supply to each area or room shall be equipped with a single, rising stem branch shut-off valve, chained and locked in the open position, labeled "EMERGENCY WATER SUPPLY".
3. The emergency water supply piping shall be at least 1-1/2" diameter.
4. Emergency water supply shall not have additional valves or stops downstream of the locked and labeled valve.
5. Identify emergency plumbing fixtures with highly visible signs. Area around them shall be well illuminated.

Product Standards:

1. Preferred manufacturers:
 - a. Acorn Safety
 - b. Bradley Corporation
 - c. Guardian Equipment
 - d. Speakman Company

Performance Standards:

1. Minimum flushing fluid:
 - a. Self-Contained Emergency Shower: 20 GPM at 30 PSI for 15 minutes.
 - b. Self-Contained Eyewash: 0.4 GPM at 30 PSI for 15 minutes.
 - c. Eye/Face wash equipment: 3 GPM at 30 PSI for 15 minutes.
2. Valve should easily activate in a second or less and remain open until it is intentionally turned off.

22 47 13 Drinking Fountains and Remote Water Coolers**Design Standards:**

1. Water coolers shall be all stainless steel finish, top, front and sides, see sections 22.3.2-10.
2. Double height units shall be provided to comply with accessibility requirements.
3. Water coolers at exterior program required locations shall have weatherized stainless steel finishes, secured remote chillers, vandal resistant components.

Product Standards:

1. Preferred manufacturers:
 - a. Oasis

- b. Halsey-Taylor
- c. Haws

Performance Standards:

1. No lead shall be allowed in the manufacture of any piece of equipment within water coolers or in any piping joint or connection within the unit.

DIVISION 22SW PLUMBING (Site Work)

This chapter identifies criteria for Water Supply, Fire Protection and Sanitary Sewer design for the University of Miami (UM) Buildings and on the site, with the purpose of establishing minimum standards, acceptable to UM, to be used as the basis of design for UM Coral Gables Campus.

- 22.1 General Requirements
 - 22.1.1 Submittals
- 22.2 Codes and Standards
 - 22.2.1 Water Supply and Fire Protection
 - 22.2.2 Sanitary Sewers
- 22.3 Design Criteria
 - 22.3.1 Water Supply and Fire Protection
 - 22.3.3 Sanitary Sewers
- 22.4 Specific Plumbing (Site work) requirements (organized by CSI MasterFormat® 2012 Numbers & Titles)

22.1 General Requirements

All work shall be designed by a Professional Civil Engineer licensed in the State of Florida.

Before the start of construction on new buildings and/or major renovations, the Contractor shall provide a drawing for each building floor level showing the coordination of all structural, architectural and MEP items. This includes, but is not limited to: Structural members, floor plates, architectural ceilings, soffits, smoke barriers, fire walls, vertical shafts, sleeves, fire dampers, HVAC ductwork and equipment, plumbing piping and equipment, fire protection piping and equipment, alarm systems, communications, electrical distribution and equipment, lighting, controls, BMS, lighting protection, security systems, etc.

The following information shall be obtained from the UM Project Manager:

1. Site surveys
2. Underground utilities information
3. Geotechnical investigation reports

The following information shall be obtained from the Miami-Dade Water and Sewer Department:

1. Water Main As-Builts

The following information shall be obtained from the City of Coral Gables Department of Public Works:

1. Sanitary Sewer As-Builts

The design of the Water Supply, Fire Protection and Sanitary Sewer systems must be implemented to have minimum impact on adjacent buildings, paved areas, vegetation or

existing waterways and aquifer. The design of water, fire protection and sanitary sewer systems shall conform to all applicable codes and regulations.

UM Coral Gables Campus Water Supply, Fire Protection and Sanitary Sewer systems design must comply with the following objectives:

1. Provide water main and their appurtenances to fulfill all the building's domestic water requirements and all of the fire protection requirements as to flows and pressures.
2. Life safety for the public, building occupants and emergency responders by minimizing fire related injuries as well as prevent loss of life.
3. Minimize fire damage to all buildings and their contents.
4. Provide sanitary sewers and their appurtenances to fulfill all of the building's sanitary sewer requirements.
5. Flexibility to allow for major and minor alterations which will occur during the typical building's life span, without causing major disruptions to other areas of the building.
6. High level of integration between architecture and the engineering systems using the latest advancements in technology.

Water Supply, Fire Protection and Sanitary Sewer systems design, in concert with other building components, shall produce a building that meets the programmed sustainability rating (LEED rating) of the specific project.

22.1.1 Submittals

Submittals shall include product data, samples, and shop drawings which are coordinated with all corresponding disciplines. The Design Professional must ensure that all submittals and shop drawings are coordinated with other disciplines.

22.2 Codes and Standards

22.2.1 Water Supply and Fire Protection

The design for Water Supply and Fire Protection Systems shall comply with the requirements of the applicable authorities having jurisdiction and with the in-force edition at the time of the project of the following codes and standards:

1. American Society of Testing and Materials (ASTM) Standards
2. American Water Works Association (AWWA)
3. Miami-Dade County Health Department
4. Miami-Dade County Permitting, Environment and Regulatory Affairs - Plans Review and Development Approval Division
5. City of Coral Gables Fire Department
6. City of Coral Gables Department of Public Works
7. Miami-Dade Water and Sewer Department (MWASD)
8. National Fire Protection Association (NFPA)

9. Florida Fire Prevention Code
10. American National Standards Institute (ANSI)
11. NSF International
12. Florida Building Code

22.2.2 Sanitary Sewers

The Sanitary Sewer system shall be designed to comply with the requirements of the applicable authorities having jurisdiction and with the in-force edition at the time of the project of the following codes and standards:

1. American Society of Testing and Materials (ASTM) Standards
2. Miami-Dade County Permitting, Environment and Regulatory Affairs - Plans Review and Development Approval Division
3. City of Coral Gables Department of Public Works
4. American National Standards Institute (ANSI)
5. NSF International
6. Florida Building Code

22.3 Design Criteria

22.3.1 Water Supply and Fire Protection

1. Water and fire mains shall be located outside the building.
2. Connections to existing water or fire mains via tapping sleeves and tapping valves for service lines shall have a diameter of two and a half (2 1/2) inches or larger.
3. Connection to existing water mains via corporation stops for service lines shall have a diameter less than two and a half (2 1/2) inches.
4. Fire hydrants shall be provided at a maximum allowable spacing of three hundred (300) feet.
5. Line sized double detector check valves for fire service lines.
6. Line sized reduced pressure backflow preventers for domestic water service lines.
7. Line sized reduced pressure vacuum breakers for irrigation lines.
8. Water meters shall be placed within concrete vaults or cast iron water meter boxes for domestic service lines.

22.3.2 Sanitary Sewer Systems

1. Sanitary sewers shall be located outside the building.
2. Precast concrete sanitary manholes shall be provided at a maximum spacing of three hundred (300) feet center to center, when necessary.
3. Provide Wye connection of service lines to existing sanitary sewers.

22.4 Specific requirements (organized by CSI MasterFormat® 2012 Numbers & Titles)

22 11 13	Facility Water Distribution Piping
22 13 13	Facility Sanitary Sewers

22 11 13 Facility Water Distribution Piping

Design Standards

1. The design of the facility water distribution piping shall include the following:
 - a. Water supply and fire protection systems quality standards:
 - (1) Quality Standard for Materials, Installations, Tests, Flushing, and Valve and Hydrant Supervision for Fire Service Main Piping: NFPA 24.
 - (2) Quality Standard for Plastic Potable-Water-Service Piping: NSF 14.
 - (3) Quality Standard for Water-Service Piping and Specialties for Domestic Water: NSF 61.
 - b. Piping materials:
 - (1) Underground water service piping NPS 3/4 to NPS 3
 - (a) Soft copper tube and copper soldier-joint fittings.
 - (b) Polyethylene pipe (PE) and insert fittings (NPS 2 or smaller).
 - (c) PVC, schedule 80 pipe and PVC schedule 80 socket fittings.
 - (2) Underground water service piping NPS 4 to NPS 8
 - (a) Ductile-iron cement mortar lined push-on-joint, flanged and mechanical-joint pipe and fittings.
 - (b) PVC, schedule 80 pipe and PVC schedule 80 socket fittings.
 - (c) PVC, AWWA C-900 and C-905 pipe and PVC fittings.
 - (3) Underground water main piping NPS 8 to NPS 16
 - (a) Ductile-iron cement mortar lined push-on-joint, flanged pipe and fittings.
 - (4) Aboveground water service piping NPS 3/4 to NPS 3
 - (a) Galvanized steel pipe and fittings.
 - (5) Aboveground fire service piping NPS 4 to NPS 8
 - (a) Ductile-iron cement mortar lined flanged and mechanical joint piping and fittings.
 - (6) Vault water service piping NPS 3/4 to NPS 8
 - (a) Soft copper tube and copper solder joint fittings.

- (b) Polyethylene pipe (PE) and insert fittings (NPS 2 or smaller).
 - (c) PVC, schedule 80 pipe and PVC schedule 80 socket fittings.
- (7) Piping specialties:
 - (a) Transition fittings.
 - (b) Tubular sleeve pipe couplings.
 - (c) Split-sleeve pipe couplings.
 - (d) Dielectric fittings.
- (8) Corrosion protection pipe encasement:
 - (a) Polyethylene encasement if required by MWASD.
- (9) Corrosion protection pipe coating:
 - (a) Asphalt coating.
- 2. The Design professional shall specify the following:
 - a. Gate valves smaller than 3-inches:
 - (1) All bronze: non-rising stem, 150 psig.
 - b. Gate valves larger than 3-inches:
 - (1) Cast iron body resiliently seated and metal seated: Non-rising stem, 150 psig.
 - c. Corporation Stops:
 - (1) NPS 1-1/4 to NPS 2 Minimum pressure rating 150 psig.
 - (2) Body Material: Brass or bronze with ball or ground-key plug.
 - (3) End Connections: Matching piping.
 - (4) Stem: With wide-tee head.
 - d. Tapping valves:
 - (1) Cast Iron body compatible with drilling machine, 150 psig.
 - e. Tapping sleeves:
 - (1) Ductile iron sleeve compatible with drilling machine .
 - f. Water meters:
 - (1) Shall be provided by WASD.
 - g. Water meter boxes and vaults:
 - (1) Water meter boxes and covers: Cast Iron.
 - (2) Vaults: Precast concrete with galvanized steel hatches.
 - h. Backflow preventers:
 - (1) Reduced Pressure Backflow Preventers for water service.
 - (2) Double Detector Check Valves for Fire Service. (Also, refer to Division 21 FIRE SUPPRESSION)
 - (3) Pressure Vacuum Breakers for irrigation.

- i. Fire hydrants (Also, refer to Division 21 FIRE SUPPRESSION):
 - (1) Dry barrel as per Coral Gables Fire Department Standards.

- i. Free standing fire department connections:
 - (1) Two inlet as per Coral Gables Fire Department Standards.

22 13 13 Facility Sanitary Sewers

Design Standards

- 1. The facility sanitary sewers shall be designed as follows:
 - a. Specification of piping materials:
 - (1) PVC Pipe PSM SDR 35 sewer pipe and fittings.
 - (2) PVC AWWA C-900 and C-905 pressure pipe and fittings.
 - (3) Ductile-iron virgin polyethylene lined push-on-joint and mechanical-joint pipe and fittings.

 - b. Design of appurtenances:
 - (1) Manholes:
 - (a) Standard precast concrete.
 - (b) Resilient type connectors
 - (c) Cast iron frame and cover
 - (d) Manhole cover inserts.

 - (2) Cleanouts:
 - (a) Heavy duty top loading classification.
 - (b) Four inch thick concrete collar.

DIVISION 23 HEATING VENTILATION AND AIR CONDITIONING

This chapter identifies criteria for the Heating, Ventilation and Air Conditioning design in University of Miami (UM) buildings and site structures with the purpose of establishing minimum standards, acceptable to UM, to be used as the basis of design for UM Coral Gables Campus.

- 23.1 General Requirements
 - 23.1.1 Submittals
- 23.2 Codes and Standards
- 23.3 Heating, Ventilation and Air Conditioning Design Criteria
- 23.4 Utility Coordination
- 23.5 Distribution System
- 23.6 Mechanical Rooms
- 23.7 Specific Mechanical Requirements (organized by CSI Masterformat® 2012 Numbers & Titles)

23.1 General Requirements

All work shall be designed by a Professional Mechanical Engineer licensed in the State of Florida.

Before the start of construction on new buildings and/or major renovations, the Contractor shall provide a drawing for each building floor level showing the coordination of all structural, architectural and MEP items. This includes, but is not limited to: Structural members, floor plates, architectural ceilings, soffits, smoke barriers, fire walls, vertical shafts, sleeves, fire dampers, HVAC ductwork and equipment, plumbing piping and equipment, fire protection piping and equipment, alarm systems, communications, electrical distribution and equipment, lighting, controls, BMS, lighting protection, security systems, etc.

UM Coral Gables Campus and UM Buildings heating, ventilation and air conditioning design must comply with the following objectives:

1. Sustainable Design.
2. Flexibility to allow for major and minor alterations which will occur during the typical building's life span, without causing major disruptions to other areas of the building.
3. High level of integration between architecture and the engineering systems using the latest advancements in technology.
4. Solutions with the best value considering a life cycle cost analysis to account for the total project cost.

The design of the heating, ventilation and air conditioning system, in concert with other building components, shall produce a building that meets the programmed sustainability rating (LEED rating) of the specific project.

23.1.1 Submittals

Submittals shall include product data, samples, and shop drawings which are coordinated with all corresponding disciplines. All submittals, unless otherwise indicated, shall adhere to the requirements outlined in Section 013300 – Submittals. The Design Professional must ensure that all submittals and shop drawings are coordinated with other disciplines. In addition, submittals shall follow the guidelines listed below:

1. Submittals related to more than one section of this division of the specifications shall be bound together and submitted simultaneously; partial submittals covering less than one section will not be checked. Partial submittals of piping and ductwork shop drawings may be made.
2. The initial submittal shall include a complete listing of all submittals for the project in three ring binders with index and tabbed sectional dividers indicating the contents of each section. Provide dividers for each specification section and for each type of equipment in each section. Divider tabs shall be typed and shall include the specification section number and the name of the equipment.
3. Include performance curves on all pumps and fans rated over 3 HP and curves or tables for smaller units. Any deviations from specified equipment shall be clearly noted in red, and such deviations shall be noted in the Contractor's transmittal letter.
4. Before furnishing electric motors, heaters and other equipment that includes electrically operated components, the Contractor shall verify that the voltage, phase and Hertz ratings conform to the electrical characteristics of the circuits shown for the equipment on the electrical drawings. For all electric equipment, submit signed statement the electrical requirements have been coordinated with the requirements on the electrical drawings.
5. Submit field test report for each inspection and test specified in this division, for information. Describe inspections and tests, list observations, indicate corrective action taken, and state conclusions and recommendations for future action.
6. Shop drawings of ductwork and piping layouts shall be as described in the applicable section.
7. The Contractor shall cross-check shop drawings of ductwork, piping and equipment against each other and against the contract drawings to avoid interference and coordinate the work.
8. One additional copy of all final corrected shop drawings and product data submissions for HVAC systems shall be furnished labeled "for the Test & Balance Agency".

9. Product data submittals shall be made on the following items:
 - a. All items with the manufacturers specified.
 - b. All items with motors or electrical equipment or burners or automatic controls.
 - c. Valves, stops, hydrants, and tanks.

10. Submittals shall include the following information:
 - a. Product data:
 - (1) Equipment capacity at design conditions.
 - (2) Shipping weight.
 - (3) Installed weight.
 - (4) Operating weight.
 - (5) Furnished specialties and accessories.
 - (6) Installation instructions.
 - (7) Start-up instructions.
 - b. Shop drawings shall indicate the following:
 - (1) Equipment dimensions.
 - (2) Weight distribution.
 - (3) Required clearances.
 - (4) Methods of assembly.
 - (5) Location and size of all field connections.
 - c. Wiring diagrams:
 - (1) Required power supply.
 - (2) Control ladder diagram including interlocks.
 - (3) Clearly differentiate between factory-installed wiring and field-wiring.

11. Sleeve and Insert Layout Drawings: Submit drawings to show the size and locations of all mechanical equipment sleeves and openings through structural elements for piping and ducts. Submit drawings showing inserts located in post tensioned or pre-stressed structural elements for support of piping, ducts and mechanical equipment.

12. Project Record Documents: In addition to the requirements outlined in Section 017800, upon completion of installation, submit three copies of record (as-built) documents. Provide the specified number of copies on both paper and as electronic media.
 - a. Drawings shall be submitted in both DWG or DXF and PDF format.
 - b. Approved submittal data, as-built information, construction test reports, checklists, manufacturer O & M manuals and training manuals shall be submitted as Adobe PDF files. PDF files shall be organized with Bookmarks. Provide Bookmarks for each Specification Section, each type of equipment. PDF shall be generated directly from Adobe and shall be word searchable. Scanned images are not acceptable.
 - c. The documents shall be submitted for approval prior to final completion and shall include:

- (1) Buried Piping: Mark the actual installed depths (invert elevations) of all buried piping and show the measured horizontal distances from permanent features such as building walls on record drawings. Mark all changes in the location of piping, ducts and equipment in accordance with Section 018000 - Project Record Documents.
 - (2) Shop Drawings, corrected for as-built condition, for all systems including piping and ductwork.
- d. Operating and Maintenance Manuals
- (1) Provide manuals as required by Section 016100 - Product Requirements as described under heading of Operating and Maintenance Data. Use multiple binders if a single binder would exceed 2-1/2 inches in thickness. Arrange the data in the same sequence as the specification sections; delete or mark through extraneous data. Furnish 4 copies of manuals for work in Division 23.
 - (2) Provide tab pages with metal or plastic reinforced holes to separate each major item or closely related group of items with typed item names on the tabs. Supply a table of contents at the beginning of each volume listing all items, the manufacturers and the name, address and phone number of the nearest authorized service representative.
 - (3) Manuals shall be submitted to A/E for approval within two weeks of approval of submittal data.
 - (4) Manuals shall include the following:
 - (a) Valve lists for the various piping systems.
 - (b) Schedule of all air filters.
 - (c) Equipment performance curves and tables (from submittal data).
 - (d) Control diagrams of factory wired equipment.
 - (e) Temperature control system product data and shop drawings.
 - (f) Warranties and guarantees that extend more than one year from the date of Substantial Completion, bound in Copy No. 1.
 - (5) Approved submittal data for all equipment, manuals shall be provided that include:
 - (a) Equipment start-up and shutdown procedures.
 - (b) Troubleshooting procedures.
 - (c) Parts list.
 - (d) Equipment servicing.
 - (e) Preventative maintenance schedules and procedures.
 - (f) List of special tools required for maintenance.
 - (g) Maintenance instruction.
 - (h) Lubrication requirements.

3. Quality Assurance
 - a. All work shall comply with the Building Codes
 - b. Manufacturer's Qualifications: Firms regularly engaged in manufacture of mechanical products of types and sizes required, and whose products have been in satisfactory use in similar service for not less than 5 years unless specified otherwise in another section of this specification.
 - c. Installer's Qualifications: Firm with not less than 5 years of experience installing equipment and products similar to that required for this project unless specified otherwise in another section of this specification
4. Asbestos Prohibition
 - a. Asbestos and asbestos-containing products shall not be used.
5. Manufacturers
 - a. Manufacturers listed in this specification will only be considered provided they comply with all of the requirements of the Drawings and Specifications. A manufacturer's listing in this specification does not ensure that the manufacturer's product meets the requirements of the Drawings and Specifications.
 - b. All equipment and materials shall be new unless noted otherwise.

23.2 Codes and Standards

The design of mechanical systems, shall comply with the requirements of the applicable authorities having jurisdiction, and with the in-force edition at the time of the project of the following codes and standards:

1. Florida Building Code, Mechanical; including all Referenced Standards.
2. ASHRAE Standards
3. National Fire Protection Association (NFPA).
4. City of Coral Gables, Local Codes and Ordinances
5. American Disabilities Act (ADA) Latest Edition.

23.3 Design Criteria

1. Cooling needs served by UM chilled water loop.
2. Dedicated chilled water system, water cooled or air cooled, connected to the EBMS, only where the campus chilled water loop is not accessible. If this option is used, provisions shall be made for future connection to the campus' chilled water system expansion.
3. Dedicated direct expansion equipments, using split type or package roof top type systems. This is the last choice and must be approved in writing by the University of Miami Building Standards (UMBS) Committee.

- 4, Design Parameters:
 - a. Outdoor Design Conditions:

(1)	Summer (General) (1.0% DB/WB)	91°F DB / 79°F WB
(2)	Summer (Dedicated Outdoor Air Units) (0.4% DB, 0.4% Evap WB)	91°F DB, 80°F WB
(3)	Condensing Units (0.4% DB + 4°F)	95°F DB
(4)	Evaporative Cooling Equipment (0.4% Evap WB + 1°F)	81°F WB
(5)	Winter (99.0% DB)	46°F DB
(6)	ASHRAE 90.1 Weather Zone:	1A
 - b. Indoor Design Conditions:
The follow summary is for general information only; specific conditions are indicated in the calculations, herein:

(1)	Classrooms, Offices, Auditoriums	(Summer)	74°F/50% rh. (uncontrolled)
		(Winter)	70°F.
(2)	Laboratories	(Summer)	74°F/50% rh. (controlled)
		(Winter)	70°F.
(3)	Electrical Rooms, Telecommunication Rooms, Mechanical Rooms	(Summer)	76°F/50% rh.
		(Winter)	68*
(4)	Other types of spaces:	ASHRAE 55 Latest Edition	
 - c. Ventilation Requirements: Outdoor Air (min.): Complies with edition in effect of ASHRAE Standard 62.1 or Florida Mechanical Code. Compliance with ASHRAE 62.1 “Ventilation Rate Procedure” is required for all LEED projects.
 - d. Minimum Envelop Heat Transfer Coefficients: Complies with edition in effect of ASHRAE Standard 90.1.
 - e. Electrical Power Limits: If actual quantities are not available; lighting power densities shall be per ASHRAE Standard 90.1 and miscellaneous equipment shall be per ASHRAE Fundamentals “Nonresidential Heating and Cooling Load Calculations”.
5. The noise criteria for HVAC design shall conform to latest editions of ASHRAE Handbooks. Acceptable acoustics are determined by the use of a space and the requirements of its occupants.
6. The HVAC system for every new project shall consider a safety factor of 50% unless otherwise indicated, in writing, by UM Authorities.
7. Direct driven equipment with variable frequency drives (VFD) are the preferred choice for HVAC equipment selection. Belt driven equipments are also acceptable.

8. Non-metal HVAC ductwork is not allowed.
9. Approved manufacturers for major HVAC equipment shall be: Trane, York, McQuay and Carrier. Other manufacturers are subject to UMBS Committee approval.
10. Provide access doors for all maintenance items above inaccessible ceilings and into inaccessible walls. Provide fire rated access doors as required to maintain the fire rating.
11. Locate filter boxes and equipment that requires maintenance, outside of the critical areas served, so that items can be serviced without disrupting operations in the room or releasing contaminants into space.
12. Locate fan coil units, terminal boxes, and other equipment containing water over hallways rather than occupied or critical spaces wherever possible. Where necessary to locate such equipment over such spaces, provide secondary drain pans.
13. In atriums or other multi-story open to roof areas, maintenance and accessibility shall be a consideration when mounting fans, lights and other equipment above the floor.
14. Primary manufacturer/model number to be specified for various types of mechanical equipment is specified herein. Provide a minimum of two additional and equivalent value manufacturers and model numbers for each primary manufacturer and model number listed.
15. Process cooling requirements shall be addressed by a dedicated process cooling system.
16. Process cooling shall not be achieved using the building chilled water system, the campus chilled water system or the building domestic water system.

23.4 Utility Coordination

Detailed information of Chilled Water pipes size and location shall be provided to the UM civil engineer for coordination with other utilities and connection to UM's Chilled Water loop.

23.5 Air Distribution System

1. The air distribution system for new projects shall be variable volume type using single duct VAV (Variable Air Volume) boxes with electric heating for perimeter areas. The core areas shall be provided with cooling only, except as required to

meet ASHRAE 62.1 Minimum Ventilation Standards. Non-typical spaces shall be designed according to their specific requirements.

2. All HVAC ducts shall be made of galvanized sheet metal in accordance to the latest edition of SMACNA Standards. All ductwork shall be constructed to meet required pressure classification. Flexible ducts are allowed to connect the main trunk to the air terminals only. Flexible ducts exceeding 10 feet in length are not acceptable. All HVAC ducts shall be insulated using a minimum R-Value of 6.
3. Ductwork dedicated to special services, such as kitchen exhaust, acid fumes exhaust, clothes dryer exhaust, etc., shall be constructed in strict compliance with applicable codes and standards.
4. Provide aluminum ducts, grilles and diffusers in showers or other areas of high humidity.
5. Where fume hoods are present, provisions must be made for make-up-air, such as hoods being of the "add-air" or "auxiliary-air" design and including a motor operated shut off valve in the exhaust stack. All laboratories' make-up air shall be pre-conditioned to conform to ASHRAE and IAQ standards.
6. The use of ceiling return plenums shall be avoided.
7. No interior duct insulation (liner) shall be used. Utilize duct sound attenuators for noise control. Sound attenuator liners shall be protected by an acrylic coating and by internal perforated sheet metal to avoid exposed fibers in airstreams.
8. Duct insulation shall be by use of one of the following:
 - a. Exterior duct wrap.
 - b. Factory fabricated double wall metal duct with solid metal inner wall with insulation between walls.
 - c. Factory fabricated double wall metal duct with perforated metal inner wall with insulation between walls and 2 mil thick Mylar between inner liner and insulation. (Use this method only where noise is of particular concern)
 - d. Double wall construction shall be specified for Air Handling Units, Fan Coil Units, Variable Air Volume Boxes or other Terminal Boxes. Insulation shall be between the inner and outer walls. The inner wall shall be solid metal (not perforated) so that no insulation is exposed to the air stream.
 - e. Ductwork that is exposed to the weather shall be double wall, smooth inside and out, insulated, with flanged connections. Joints shall be insulated and the outside panel painted with weather resistant paint or is stainless steel exterior.

23.6 Mechanical Rooms

1. Mechanical rooms shall be lockable and accessible only to qualified persons; and not accessible to professors, students or used for storage.
2. Mechanical rooms shall be sized to accommodate all the mechanical equipment to be installed, including recommended installation clearances, maintenance space and coils pull out space for air handling units. Minimum size shall be as required by Code to accommodate all necessary equipment. Provide Mechanical Room with double doors swinging out.
3. Return and outside air duct connections to air handlers shall be ducted. Do not use room as a return air plenum. Mechanical rooms shall be air conditioned.
4. When choosing the location for the mechanical room, consider the noise, heat output, ventilation requirements, power requirements, drainage, water and fuel.
5. Provide sufficient access to the room to allow for the replacement of the largest piece of equipment.
6. Locate mechanical rooms so that they are clear of columns, beams, shear walls, stairways, duct shafts, elevators and other obstructions to permit a clear running of the HVAC ductwork and piping.
7. Rooms shall be sprinklered and located in fully sprinklered facilities.

23.7 Laboratory Buildings

1. "Manifolding" or mixing of general laboratory exhaust and exhaust directly from fume hoods is allowable as long as it is accomplished in compliance with any applicable building and life safety codes. Fumes and general exhaust must be separate in all new construction.
2. Where fume hoods and general room exhaust streams are combined, the duct shall be round stainless steel type 316 ductwork with welded seams and flanged or welded connections. The stainless steel ductwork shall be run from the point of collection (hood connection or room exhaust grille/inlet) to the main riser for that portion of the building. Ducts risers may be constructed of stainless steel. Additional anti-corrosion coating shall be provided whenever the duct system conveys highly corrosive fumes. Where exhaust streams are NOT combined, only the fume hood exhaust ductwork need be run in stainless steel, coated, or other suitable anti-corrosion materials.
3. No heat recovery wheels (or any other technology which does not completely separate the exhaust and intake airstreams) will be considered for energy recovery building exhausts which handle fume hood exhaust, whether combined or not.

4. Variable air volume control dampers controlling the exhaust flow from fume hoods and general room exhaust shall fail OPEN upon loss of control power or control air.
5. Emergency generators shall be sized to provide adequate power for all exhaust fans serving combined fume hood and general room exhaust systems. Supply air handler outside air intake louvers shall fail or power OPEN to prevent excessive negative building pressurization upon loss of primary power source. Supply air handlers do not have to be included in emergency generator capacity. Where fume hood exhaust is separate from general room exhaust, only the fume hood exhaust fans need to be included in calculating the emergency generator capacity.
6. Co-mingled or combined fume hood and general room exhaust systems must be considered and designed as “hazardous exhaust systems” in accordance with the International Mechanical Code, and other applicable building and life safety codes.
7. Avoid excessive negative pressure differential between the zone of fire origin (ZOFO) during an alarm and the surrounding spaces. The pressure differential between the ZOFO and the surrounding spaces shall be 0.05 in wg.

**23.8 Specific Mechanical Requirements
(organized by CSI Masterformat® 2012 Numbers & Titles)**

23 05 14	Wiring, Motors, Starters and Variable Frequency Drives for HVAC Equipment
23 05 16	Expansion Fittings and Loops for HVAC Piping
23 05 19	Meters and Gages for HVAC Piping
23 05 23	General-Duty Valves for HVAC Piping
23 05 29	Hangers and Supports for HVAC Piping and Equipment
23 05 48	Vibration and Seismic Controls for HVAC Piping and Equipment
23 05 53	Identification for HVAC Piping and Equipment
23 05 93	Testing, Adjusting, and Balancing for HVAC
23 07 00	HVAC Insulation
23 08 00	Commissioning Of HVAC
23 09 00	Instrumentation and Control for HVAC
23 09 93	Sequence of Operations for HVAC Controls
23 11 13	Facility Fuel-Oil Piping
23 11 23	Facility Natural-Gas Piping
23 11 26	Facility Liquefied-Petroleum Gas Piping

23 21 13	Hydronic Piping
23 21 23	Hydronic Pumps
23 23 00	Refrigerant Piping
23 25 00	HVAC Water Treatment
23 31 13	Metal Ducts
23 31 19	HVAC Casings
23 33 00	Air Duct Accessories
23 34 23	HVAC Power Ventilators
23 36 00	Air Terminal Units
23 37 13	Diffusers, Registers, and Grilles
23 37 23	HVAC Gravity Ventilators
23 41 00	Particulate Air Filtration
23 41 33	High-Efficiency Particulate Filtration
23 57 00	Heat Exchangers for HVAC
23 64 16	Centrifugal Water Chillers
23 64 23	Scroll Water Chillers
23 64 26	Rotary-Screw Water Chillers
23 64 27	Magnetic Bearing Chillers
23 64 28	Chiller Plant Requirements
23 65 00	Cooling Towers
23 72 00	Air-To-Air Energy Recovery Equipment
23 73 13	Modular Central-Station Air-Handling Units
23 74 13	Packaged, Outdoor, Central-Station Air-Handling Units
23 74 33	Packaged, Outdoor or Rooftop Air Conditioning Units
23 81 13	Packaged Terminal Air-Conditioners
23 81 23	Computer-Room Air-Conditioners
23 81 26	Split-System Air-Conditioners
23 82 16	Air Coils
23 82 19	Fan Coil Units

23 05 14 Wiring, Motors, Starters and Variable Frequency Drives for HVAC Equipment

Design Standards:

1. Motors for HVAC equipments shall provided sufficient capacity to start, accelerate, and operate connected loads at designated speeds, at installed altitude and environment,

with indicated operating sequence, and without exceeding nameplate ratings or considering service factor.

2. Motors for HVAC equipment shall bear a nameplate with the rated voltage, phase and frequency (in Hertz).

Product Standards:

1. Acceptable Manufacturers:
 - a. ABB.
 - b. AC Tech.
 - c. Allen Bradley.
 - d. Eaton Electrical Inc.; Cutler-Hammer Business Unit.
 - e. General Electric Company; GE Consumer & Industrial - Electrical Distribution.
 - f. Rockwell Automation, Inc.; Allen-Bradley Brand.
 - g. Siemens Energy & Automation, Inc.
 - h. Square D; a brand of Schneider Electric.
 - i. Toshiba International Corporation.
 - j. Yaskawa Electric America, Inc; Drives Division.

Performance Standards:

1. Electric Wiring
 - a. All wiring shall conform to the requirements outlined in the specifications, Division 26, Electrical.
2. Motors and Starters
 - a. Motors larger than 1/2 HP shall be 3 phase, unless noted otherwise on the drawings; 1/2 HP and smaller shall be single phase unless otherwise indicated. Motors and other electrically operated equipment shall be nameplate rated to operate with the voltage, phase and Hertz indicated on the Electrical Drawings. Motor nameplate ratings shall be 200 V for 208 V circuits, 230 V for 240 V circuits, 265 V for 277 V circuits and 460 V for 480 V circuits.
 - b. All three phase motors shall be designed for inverter duty unless noted otherwise.
 - c. All three phase motors shall meet or exceed the NEMA Premium nominal energy efficiency ratings.
 - d. Actual motor full load amperes shall not exceed full load ampere ratings as listed in NEC Article 430.
 - e. Job installed starters shall be Joslyn-Clark, Allen-Bradley, Square D, Gould, General Electric, Cutler Hammer/Westinghouse or Siemens.

- f. Starters for 3 phase motors shall be magnetic type and shall be as follows (unless otherwise indicated):
- (1) NEMA 1 enclosure, combination line starter with fused disconnect and thermal overload protection on all 3 phases. Starters outdoors shall have rainproof NEMA 3R enclosures. (Where fused disconnects are specified, provide fuses per Division 16 - Disconnect Switches.)
 - (2) 24 V coil or 120 V coil (to agree with control circuit - not to exceed 120 V) and control transformer built-in, with fuses in primary leads and in hot secondary lead, other secondary grounded.
 - (3) Two sets of auxiliary contacts plus additional interlock contacts as required for specified performance.
 - (4) Provide red running lights for all starters.
 - (5) H.O.A. control for all automatically controlled starters and remotely controlled starters. Furnish ON-OFF selector switch where there is no automatic, remote or interlock control.
 - (6) Additional starter specifications are given in other sections.
 - (7) The Short Circuit Ampere Interrupting Capacity Rating shall be as indicated on the Electrical Drawings. Coordinate the AIC rating with the electrical engineer. If AIC rating greater than 5000 amp (for starter sizes 0 thru 3) or greater than 10,000 amps (for starter sizes 4 and larger), specify a fused combination starter.
- g. Starters for single phase motors shall be manual type motor rated switches with thermal overload device (except omit overload device from switches for motors with built-in overload protection) and NEMA type 1 enclosure except for installation in toilets or public spaces or when noted for flush mounting. In such locations, furnish jumbo stainless steel flush plate and pull box. Provide red running lights for all starters.
- (1) Single phase motors remotely controlled by Building Management Control System or central Temperature Control System shall be provided with H.O.A control switch.
- h. Furnish starters (motor control switches) for all motors supplied with mechanical equipment except where starters are indicated in motor control centers on the Electrical Drawings, which are specified in the Electrical Division.
3. Variable Frequency Drives (VFD)
- a. Variable Speed Drives shall vary the speed of the induction motors. The motor speed control shall be UL, ETL or CSA approved.
 - b. The variable frequency power and logic unit shall be completely solid state with a pulse width modulated (PWM) output waveform. VVI, six-step, and current source drive are not acceptable. and shall transform 3 phase 60 Hertz input power into frequency and voltage controlled 3 phase output power suitable to provide positive speed and torque control to standard induction motors. The variable speed drive shall be completely enclosed in a NEMA 1 enclosure,

completely assembled and tested by the manufacturer. The speed control shall be step-less throughout the speed range under variable torque load on a continuous basis. The variable frequency drive shall employ a full wave rectifier (to prevent input line notching), DC Line Reactor, capacitors, and insulated Gate Bipolar Transistors (IGBT's) as the output switching device (SCR's, GTO's and Darlington transistors are not acceptable). The adjustable frequency control shall have a power factor of 0.98 or better and a drive efficiency of 0.97 percent or better at all operating speeds and loads.

- c. The Short Circuit Ampere Interrupting Capacity (AIC) Rating shall be indicated as required on the Electrical Drawings.
- d. The following features and adjustments for self-protection and reliable operation shall be included:
 - (1) PI set-point controller shall be standard in the drive, allowing a pressure or flow signal to be connected to the VFD, using the microprocessor in the VFD for the closed loop control.
- e. Surge Protection: The VFD shall be provided with protection against under voltage and overvoltage, including low energy lightning surges introduced on the primary AC source. This shall include:
 - (1) Input AC overvoltage protection for over 120% of rated voltage.
 - (2) Input AC under-voltage protection for below 65% of rated voltage.
- f. In addition to the items listed above, also provide the following:
 - (1) Current limit to 110% of the inverter rating, but not trip on momentary overload.
 - (2) Instantaneous overcurrent trip at 225% of inverter rating.
 - (3) Undervoltage trip at 65% of rated voltage.
 - (4) Overvoltage trip for DC voltage at 130% of rated voltage.
 - (5) Overtemperature trip for the inverter at 70 degree C.
 - (6) Ground fault trip, either running or at start.
 - (7) Adjustable motor overload (I squared T) trip (60 -100%).
 - (8) Adjustable current limit.
 - (9) The drive shall employ current limit circuits to provide trip free operation.
 - (10) Adjustable volts per hertz (+10%, -10%).
 - (11) Adjustable accelerate/decelerate rate (1-300 sec.).
 - (12) Adjustable minimum and maximum speeds (0-100%).
 - (13) Adjustable offset and gain of input signal.
 - (14) Two (2) programmable analog outputs proportional to Frequency, Motor Speed, Output Voltage, Output Current, Motor Torque, Motor Power (KW), DC Bus voltage, or Active Reference.
 - (15) Input signal inversion.
- g. Contacts to indicate enabled current limit and fault conditions.
 - (1) Control shall be capable of operation without a motor connected.

- h. Speed command input shall be via:
 - (1) Keypad.
 - (2) Two analog inputs, each capable of accepting a 0-20 mA, 4-20 mA, 0-10 V signal. Input shall be isolated from ground, and programmable for different uses. Analog inputs shall have a programmable filter to remove any oscillation of the reference signal. The filter shall be adjustable from 0.01 to 10 seconds. The analog input shall be able to be inverted, so that minimum reference corresponds to maximum speed, and maximum reference corresponds to minimum speed. The minimum and maximum values (gain and offset) shall be adjustable within the range of 0-20 mA and 0-10 Volts. The active analog input shall have loss of reference protection.
 - (3) Floating point input shall accept a three-wire input from a Dwyer Photohelic (or equivalent type) instrument.
- i. Door interlocked disconnect switch, fused.
- j. Contactor bypass switch with 3 contactors, motor overload relay, safety circuit terminal strip, "power on" light, mode selector and indicator lights, normal operation/test selector, and safety circuit trip light.
- k. Built-in digital display to indicate output frequency, voltage and current, speed, % torque, % power, elapsed time, and KWH.
- l. Alpha Display or Status Lights : Power On, Enabled, Overtemperature, Current Limit, Undervoltage, Overvoltage, Overcurrent and External Fault Trip.
- m. Auto restart: In the event of a momentary or sustained power loss, the control shall shut down safely without component failure. Upon return of power, the system shall automatically return to normal operation, if the system is in the "On" condition. On return to normal operation, the system shall be protected against, or able to restart into, a rotating motor, forward or reverse, and regain positive speed control without shutdown or component failure.
- n. Isolation: Current and voltage signals shall be isolated from logic circuitry.
- o. Logic: Drive logic shall be microprocessor based.
- p. Short circuit protection: In the event of a phase-to-phase short circuit or short to ground, the control shall shut down safely without component failure.
- q. Power interruption: In the event that an input or output power contactor is opened or closed while the control is activated, no damage to the control shall result.
- r. Output frequency shall not vary with +10% input voltage changes or with temperature changes within the ambient specification of 0 deg C to 40 deg C.

- s. Start/stop control: The controller shall be constructed to be started or stopped by the following:
 - (1) A start-stop push button on the door.
 - (2) Contacts for connection to a two-wire circuit to thermal overload switches in the motor, freeze-stat, smoke detector and time switch or other remote on-off control.
 - (3) Contacts for connection to remote on-off control and interlocked components such as dampers and valves.
- t. Speed control: Provide a sensing device in the motor control that will increase or decrease the fan motor speed from 2 to 10 VDC or 4 to 20 mA signal. The motor speed control shall be field adjustable for speed increase/decrease timing.
- u. AC reactor/DC Link Choke to improve the power factor and suppress the harmonic current of the inverter while in operation. Comply with IEEE 519 – Harmonic Analysis for particular jobsite including total voltage harmonic distortion and total current distortion.
- v. The VFD manufacturer shall provide calculations, specific to this installation, showing total harmonic voltage distortion is less than 5%. Input line filters shall be sized and provided as required by the VFD manufacturer to ensure compliance with IEE 519-1992, “Guide for Harmonic Control and Reactive Compensation for Static Power Converters”. The acceptance of this calculation must be completed prior to VFD installation.
- w. Prior to installation, the VFD manufacturer shall provide the estimated total harmonic distortion (THD) caused by the VFD’s. The result shall be based on a computer aided circuit simulation of the total actual system, with the information obtained from the power provider and the user.
- x. If the voltage THD exceeds 5%, the VFD manufacturer is to recommend the additional equipment required to reduce the voltage THD to an acceptable level. Existing harmonic distortion must be measured by an independent organization to assure compliance prior to the VFD evaluation.
- y. Provisions for stop and automatic re-start from external safety devices:
 - (1) After shutdown from any external safety such as fire alarm or freeze-stat, VFD shall automatically re-start when external fault or safety is cleared. Provide logic to automatically re-start VFD when external safeties are cleared.
- z. Serial Communications:
 - (1) The VFD shall have an RS-485 port as standard.
 - (2) The VFD shall be able to communicate with PLC’s, DCS’s, and DDC’s.
 - (3) Serial communication capabilities shall include, but not be limited to, run-stop control, speed set adjustment, proportional/integral PI controller adjustment, current limit, and accel/decel time adjustments.

- (4) The drive shall have the capability of allowing the DDC to monitor feedback such as output speed/frequency, current (in amps), % torque, % power, kilowatt hours, relay outputs, and diagnostic fault information.
 - (5) DCC integration shall utilize BACnet/MSTP.
- aa. Provide critical frequency jump to allow inverter to ride through resonance frequencies.
 - bb. The VFD shall be equipped with an automatic extended power loss ride-through circuit which will utilize the inertia of the load to keep the drive powered. Minimum power loss ride-through shall be one-cycle, based on full load and no inertia.
 - cc. Accessories: The variable frequency motor control units shall be provided with all accessory equipment required for self-protection, motor protection and prevention of interference in the power supply system. Units that contain SCR's or other devices that create line notching shall have isolation transformer. Provide data line module to allow RS 232 link for personal computer to allow PC control of start/stop, forward/reverse, frequency, status, and mode.

23 05 16 Expansion Fittings and Loops for HVAC Piping

Design Standards:

- 1. Expansion fittings and loops for HVAC piping shall be designed to prevent damages on piping systems due to dimensional changes that occurs for temperature variations in the fluid being carried.
- 2. Welding joints for expansion loops shall be according to ASME Boiler and Pressure Vessel Code: Section IX, "Welding and Brazing Qualifications."

Product Standards:

- 1. Materials shall be corrosion resistant.

Performance Standards:

- 1. Expansion fittings shall have the capability to absorb 200 percent of maximum piping expansion between anchors. These fittings must be compatible with the product suitable for piping system fluids, materials, working pressures, and temperatures.

23 05 19 Meters and Gages for HVAC Piping**Design Standards:**

1. Meters and gauges shall be installed in strict accordance with the manufacturer's recommendations for orientation, required straight length of upstream/downstream position. Pressure ports shall not be pointed downward to prevent the accumulation of trash and debris inside the ports

Product Standards:

1. Thermometers, General
 - a. Scale Range: Temperature ranges for services listed are as follows:
 - (1) Domestic Hot Water: 30 to 240 deg F, with 2-degree scale divisions.
 - (2) Domestic Cold Water: 0 to 100 deg F, with 2-degree scale divisions.
 - (3) Chilled Water: 0 to 100 deg F, with 2-degree scale divisions.
 - (4) Heating Hot Water: 0 to 200 deg F, with 2-degree scale divisions.
 - b. Accuracy: Plus or minus 1 percent of range span or plus or minus one scale division to maximum of 1.5 percent of range span.
 - c. 5 inch diameter face minimum, stainless steel housing.
2. Liquid-In-Glass Thermometers
 - a. Description: ASTM E 1.
 - b. Case: Die cast and aluminum finished in baked-epoxy enamel, glass front, spring secured, 9 inches long.
 - c. Adjustable Joint: Finish to match case, 180-degree adjustment in vertical plane, 360-degree adjustment in horizontal plane, with locking device.
 - d. Tube: Red or blue reading, organic-liquid filled with magnifying lens.
 - e. Scale: Satin-faced non-reflective aluminum with permanently etched markings.
 - f. Stem: Copper-plated steel, aluminum, or brass for separable socket; of length to suit installation.
3. Separable Sockets
 - a. Description: Fitting with protective socket for installation in threaded pipe fitting to hold fixed thermometer stem.
 - (1) Material: Brass, for use in copper piping.
 - (2) Material: Stainless steel, for use in steel piping.
 - (3) Extension-Neck Length: Nominal thickness of 2 inches, but not less than thickness of insulation. Omit extension neck for sockets for piping not insulated.
 - (4) Insertion Length: To extend to center of pipe.
4. Thermometer Wells
 - a. Description: Fitting with protective well for installation in threaded pipe fitting to hold test thermometer.
 - (1) Material: Brass, for use in copper piping.
 - (2) Material: Stainless steel, for use in steel piping.

- (3) Extension-Neck Length: Nominal thickness of 2 inches, but not less than thickness of insulation. Omit extension neck for wells for piping not insulated.
 - (4) Insertion Length: To extend to center of pipe.
 - (5) Cap: Threaded, with chain permanently fastened to socket.
5. Pressure Gages
 - a. Description: ASME B40.1, phosphor-bronze bourdon-tube type with bottom connection; dry type, unless liquid-filled-case type where gages are connected across pumps and chillers.
 - b. Case: Brass, or aluminum with 4-1/2-inch-diameter, glass lens.
 - c. Connector: Brass, NPS 1/4.
 - d. Scale: White-coated aluminum with permanently etched markings.
 - e. Accuracy: Grade A, plus or minus 1 percent of middle 50 percent of scale.
 - f. Range: Comply with the following:
 - (1) Vacuum: 30 inches Hg of vacuum to 15 psig of pressure.
 - (2) Fluids under Pressure: Two times the operating pressure.
 - g. Extension-Neck Length: Insulated Piping – Omit extension neck for wells for piping not insulated.
 - h. Pressure transmitters are to be selected such that the pressure range midpoint shall coincide with the anticipated normal operating pressure.
6. Pressure-Gage Fittings
 - a. Valves: NPS 1/4 brass or stainless-steel needle type.
 - b. Syphons: NPS 1/4 coil of brass tubing with threaded ends.
 - c. Snubbers: ASME B40.5, NPS 1/4 brass bushing with corrosion-resistant porous-metal disc of material suitable for system fluid and working pressure.
7. Test Plugs
 - a. Description: Nickel-plated, brass-body test plug in NPS 1/2 fitting.
 - b. Body: Length as required to extend beyond insulation.
 - c. Pressure Rating: 500 psig minimum.
 - d. Core Inserts: Two self-sealing valves, suitable for inserting 1/8-inch OD probe from dial-type thermometer or pressure gage.
 - e. Core Material for Air, Water, Oil, and Gas: 20 to 200 deg F, chlorosulfonated polyethylene synthetic rubber.
 - f. Core Material for Air and Water: Minus 30 to plus 275 deg F, ethylene-propylene-diene terpolymer rubber.
 - g. Test-Plug Cap: Gasketed and threaded cap, with retention chain or strap.
 - h. Test Kit: Pressure gage and adapter with probe, two bimetal dial thermometers, and carrying case.
 - (1) Pressure Gage and Thermometer Ranges: Approximately two times the system's operating conditions.
8. Flow-Measuring Systems
 - a. System includes calibrated flow element, separate meter, hoses or tubing, valves, fittings, and conversion chart compatible with flow element, meter, and system fluid.

- (1) Flow range of flow-measuring element and meter covers operating range of equipment or system where used.
 - (2) Display: Visual instantaneous rate of flow.
 - b. Portable Meters: Differential-pressure gage. Include two 12-foot hoses in carrying case with handle.
 - (1) Scale: Inches of water, unless otherwise indicated.
 - (2) Accuracy: Plus or minus 2 percent between 20 and 80 percent of range.
 - c. Include complete operating instructions with each meter.
 - d. Venturi Flow Elements: Differential-pressure-design, flow-element fitting made for installation in piping.
 - (1) Construction: Bronze, brass, or factory-primed steel; with brass fittings and attached tag with flow conversion data. Include ends threaded for NPS 2 and smaller elements and flanged or welded for NPS 2-1/2 and larger elements.
 - (2) Pressure Rating: 250 psig.
 - (3) Temperature Rating: 250 deg F.
9. Vortex-Shedding Flowmeters
 1. Insertion Vortex-Shedding Flowmeter: Made for installation in pipe; measures flow directly in gallons per minute.
 2. Construction: Stainless-steel probe, with integral transmitter and direct-reading scale.
 - (1) Pressure Rating: 1000 psig minimum.
 - (2) Temperature Rating: 500 deg F minimum.
 - (3) Display: Visual instantaneous rate of flow.
 - (4) Integral Transformer: For low-voltage power connection.
 - (5) Accuracy: Plus or minus 1 percent for liquids and 1-1/2 percent for gases.
 - (6) Output: 0-10 DC, 4-20 mA.
 - (7) Special: Hot tap assembly.
10. Turbine Flow Meters
 - a. Flow meter shall be four-dual turbine flow meter:
 - (1) For use as flow monitoring in central plant and distribution loop chilled water, hot water, and condenser water flow measurement applications.
 - (2) The Flow Meter shall provide analog outputs for flow rate for connection to the central control system.
 - (3) The Flow Meter shall be "hot tap" style flow sensor, which can be installed, serviced and recalibrated without system shutdown.
 - b. General Description:

Furnish and install an Insertion Flow Meter complete with all installation hardware necessary to enable insertion and removal of the flow meter under pressure without system shutdown. When dictated by short available pipe runs, the flow measurement station shall provide compensation for rotational distortion in the velocity flow profile caused by upstream conditions. Each sensor shall be covered by a manufacturer's two-year "No Fault" warranty.

- c. Accuracy & Calibration:
Each flow sensor shall be individually wet-calibrated and tagged accordingly against the manufacturer's primary volumetric standards, which must be accurate to within 0.1% and traceable to the U.S. National Institute of Standards and Technology (NIST). The manufacturer shall provide a certificate of NIST traceable wet-calibration for each sensor. Accuracy shall be as follows:
 - (1) + 0.5% of actual reading at the calibrated typical velocity
 - (2) + 1% of reading over a 10:1 turndown (from 3 to 30 ft/s)
 - (3) + 2% of reading over a 50:1 turndown (from 0.4 to 20 ft/s)
 - (4) Overall rangeability shall be from 0.17 ft/s to 30 ft/s (175:1 turndown ratio).
 - d. General Specifications:
The sensor shall have a maximum operating pressure of 400 PSI, maximum operating temperature of 200^o F and a pressure drop of less than 1 PSI at 17 feet per second flow velocity. The flow sensor shall be constructed of plated brass with standard features to include a weather-tight aluminum electronics enclosure and ½" conduit connection fitting.
 - e. Electronic Outputs:
The sensor shall have two integral analog outputs, one 0-10 VDC and one 4-20 mA, for connection to a Central Control System. The sensor shall also include integral frequency outputs for diagnostic purposes and for connection to local display. All outputs shall be linear with flow rate.
11. Flow Indicators
- a. Description: Instrument for visual verification of flow; made for installation in piping systems.
 - b. Construction: Bronze or stainless-steel body, with sight glass and plastic pelton-wheel indicator.
 - c. Pressure Rating: 125 psig.
 - d. Temperature Rating: 200 deg F.

Performance Standards:

- 1. Meters and Gauges shall be calibrated according to the manufacturer recommendations and the procedures established by the U.S. National Institute of Standards and Technology (NIST). The manufacturer shall provide a certificate of NIST traceable wet-calibration for each device.

23 05 23 General-Duty Valves for HVAC Piping

Design Standards:

- 1. Ferrous valve dimensions and design criteria shall comply with ASME B16.10 and ASME B16.34. Power piping valves shall comply with ASME B31.1. Building services piping valves shall comply with ASME B31.9.

2. Valve pressure and temperature ratings shall not be less than that required for system pressures and temperatures.
3. Ball, butterfly or gate valves shall be used for shut-off service applications. Ball valves shall be lug type.
4. Provide ball valves on chilled and hot water supply and return piping with balancing cock on return line to all air handling units. Provide ball valves and tee handle up to 3". Provide two-way modulating valves on chilled and hot water return lines at all air handling units. Provide gauge cocks and thermometer wells on supply and return piping on all air handling units.
5. In most cases, valve sizes shall be the same as upstream piping.
6. The following valve actuator types shall be used:
 - a. Gear Actuator: For quarter-turn valves NPS 8 and larger.
 - b. Handwheel: For valves other than quarter-turn types.
 - c. Handlever: For quarter-turn valves NPS 6 and smaller except plug valves.
 - d. Wrench: For plug valves with square heads. Furnish Owner with 1 wrench for every 5 plug valves, for each size square plug-valve head.
 - e. Chainwheel: Device for attachment to valve handwheel, stem, or other actuator; of size and with chain for mounting height.
7. Valves in insulated piping shall be provided with 2-inch stem extensions and the following features:
 - a. Gate Valves: With rising stem.
 - b. Ball Valves: With extended operating handle of non-thermal-conductive material, and protective sleeve that allows operation of valve without breaking the vapor seal or disturbing insulation.
 - c. Butterfly Valves: With extended neck.
8. Valve-End Connections shall be in accordance with the following:
 - a. Flanged: With flanges according to ASME B16.1 for iron valves.
 - b. Grooved: With grooves according to AWWA C606.
 - c. Solder Joint: With sockets according to ASME B16.18.
 - d. Threaded: With threads according to ASME B1.20.1.
9. The following valves shall be used for chilled water piping with a diameter of 2 inches or less:
 - a. Bronze Valves: May be provided with solder-joint ends instead of threaded ends.
 - b. Bronze Angle Valves: Class 125, bronze or nonmetallic disc.
 - c. Ball Valves: Two, three piece, full port, bronze with bronze trim.
 - d. Bronze Swing Check Valves: Class 125, bronze or nonmetallic disc.
 - e. Bronze Gate Valves: Class 125, bronze.
 - f. Bronze Globe Valves: Class 125, bronze or nonmetallic disc.

10. The following valves shall be used for chilled water piping with a diameter of 2-1/2 inches or more:
 - a. Iron Valves, NPS 2-1/2 to NPS 4: May be provided with threaded ends instead of flanged ends.
 - b. Iron Ball Valves, NPS 2-1/2 to NPS 10: Class 150.
 - c. Iron, Single-Flange Butterfly Valves, NPS 2-1/2 to NPS 12: 200 CWP, EPDM or NBR seat, aluminum-bronze stainless-steel disc.
 - d. Iron Swing Check Valves: Class 125, metal or nonmetallic-to-metal seats.
 - e. Iron Swing Check Valves with Closure Control, NPS 2-1/2 to NPS 12: Class 125, lever and spring.
 - f. Iron, Grooved-End Check Valves, NPS 3 to NPS 12: 300 CWP.
 - g. Iron, Center-Guided Check Valves: Class 125, compact-wafer, metal, resilient seat.
 - h. Iron, Plate-Type Check Valves: Class 125; single dual plate; metal, resilient seat.
 - i. Iron Gate Valves: Class 125.
 - j. Iron Globe Valves: Class 125.
 - k. Lubricated Plug Valves: Class 125, regular gland or cylindrical, threaded or flanged.
 - l. Eccentric Plug Valves: 175 CWP, resilient seating.
11. The following valves shall be used for heating water piping with a diameter of 2 inches or less:
 - a. Bronze Valves: May be provided with solder-joint ends instead of threaded ends.
 - b. Bronze Angle Valves: Class 125, bronze disc.
 - c. Ball Valves: Two piece, full regular port, bronze with bronze trim.
 - d. Bronze Swing Check Valves: Class 125, bronze disc.
 - e. Bronze Gate Valves: Class 125,.
 - f. Bronze Globe Valves: Class 125, bronze disc.
12. The following valves shall be used for heating water piping with a diameter of 2-1/2 inches or more:
 - a. Iron Valves, NPS 2-1/2 to NPS 4: May be provided with threaded ends instead of flanged ends.
 - b. Iron Ball Valves, NPS 2-1/2 to NPS 10: Class 150.
 - c. Iron, Single-Flange Butterfly Valves, NPS 2-1/2 to NPS 12: 200 CWP, EPDM or NBR seat, aluminum-bronze ductile-iron, stainless-steel disc.
 - d. Iron, Single-Flange Butterfly Valves, NPS 14 to NPS 24: 150 CWP, EPDM or NBR seat, aluminum-bronze, ductile-iron, stainless-steel disc.

Product Standards:

1. Preferred Manufacturers:
 - a. Crane Co.
 - b. Flo Fab Inc.
 - c. Hammond Valve.
 - d. Kitz Corporation.
 - e. Legend Valve.

- f. Milwaukee Valve Company.
- g. Powell Valves.
- h. Red-White Valve Corporation.
- i. Watts Regulator Co.

23 05 29 Hangers and Supports for HVAC Piping and Equipment

Design Standards:

1. Structural Performance: Hangers and supports for HVAC piping and equipment shall withstand the effects of gravity loads and stresses within limits and under conditions indicated according to ASCE/SEI 7.
2. Design supports for multiple pipes capable of supporting combined weight of supported systems, system contents, and test water.
3. Design equipment supports capable of supporting combined operating weight of supported equipment and connected systems and components.

Product Standards:

1. Pipe Hangers and Supports
 - a. Hangers for Pipe Sizes 1/2 to 1-1/2 Inches: Carbon steel, adjustable swivel, split ring.
 - b. Hangers for Pipe Sizes 2 to 4 Inches: Carbon steel, adjustable, clevis.
 - c. Multiple or Trapeze Hangers: Steel channels with welded spacers and hanger rods.
 - d. Wall Support for Pipe Sizes to 3 Inches: Cast iron hook.
 - e. Wall Support for Pipe Sizes 4 Inches and Over: Welded steel bracket and wrought steel clamp.
 - f. Vertical Support: Steel riser clamp.
 - g. Floor Support for Pipe Sizes Up to 4 Inches and All Cold Pipe Sizes: Cast iron adjustable pipe saddle, locknut, nipple, floor flange and concrete pier or steel support.
 - h. Copper Pipe Support: Carbon steel ring, adjustable, copper plated.
 - i. Shield for Insulated Piping 2 Inches and Smaller: 18 gauge galvanized steel shield over insulation in 180 degree segments, minimum 12 inches long at pipe support.
 - j. Shield for Insulated Piping 2-1/2 Inches and Larger (Except Cold Water Piping): Pipe covering protective saddles.
 - k. Shields for Vertical Copper Pipe Risers: 1/8 inch thick minimum neoprene sheet.
 - l. Use double nuts and lock washers on threaded rod supports.

- 2. Duct Hanger Straps
 - a. 1 inch x 18 gauge galvanized steel fastened with screws to rectangular ducts and with a bolt to round ducts.

- 3. Hanger Rods
 - a. Hanger rods for steel wrought iron and brass pipe shall be installed in accordance with the following schedule:

Pipe Size	Rod Diameter	Maximum Spacing
Up to 3"	3/8"	8'-0"
4"	1/2"	10'-0"
5" and Up	5/8"	10'-0"

- b. Hanger rods for copper pipe and tube shall be installed in accordance with the following schedule:

Pipe Size	Rod Diameter	Maximum Spacing
Up to 1"	3/8"	6'-0"
1-1/4" and 1-1/2"	3/8"	8'-0"
2"	3/8"	9'-0"
2-1/2"	1/2"	9'-0"
3" and 4"	1/2"	10'-0"

- 4. Roof Curbs
 - a. Curbs to be a minimum of 18 inches high for either finished flat roofs or finished pitched roofs, manufactured of 18 gauge galvanized steel shell and base with a mitered 3 inch cant, continuously welded longitudinal seams and metal corners, internally reinforced with bulkheads and spreaders on 24 inch centers, factory insulated with 1-1/2 inch thick/3 PCF density fiberglass board insulation, factory installed 2 inch x 4 inch wood nailer strip, gasketing and 18 gauge galvanized steel counter-flashing. Curb to be of the same manufacturer of the equipment that it will support. See Architectural Division.

- 5. Sleeves
 - a. Sleeves for Pipes through Non-Fire Rated Floors: 18 gauge galvanized steel.
 - b. Sleeves for Pipes through Underground Non-Fire Rated Walls and Footings: Schedule 40 PVC.
 - c. Sleeves for Pipes through Fire Rated Walls and Floors: Factory fabricated UL fire rated sleeves including seals.
 - d. Sleeves for Rectangular Ductwork: Galvanized steel.
 - e. Sleeves for Round Ductwork: Galvanized Steel.

6. Fabrication
 - a. Size sleeves large enough to allow for movement due to expansion and contraction. Provide for continuous insulation wrapping.
 - b. Design hangers without disengagement of supported pipe.
 - c. Provide copper plated hangers and supports for copper piping and 1/8 inch minimum thick neoprene sheet packing between hanger or support and ferrous piping.

23 05 48 Vibration Controls for HVAC Piping and Equipment

Design Standards:

1. Concrete Inertia Bases. Inertia bases shall be provided for reciprocating and centrifugal chillers, air compressors, all pumps, axial fans above 300 RPM, and centrifugal fans above 37.3 kW (50 hp).
2. Flexible duct connections shall be provided at fan outlets and inlets or AHU supply and return duct connections to minimize vibration transmission through ducts, except for smoke control and kitchen exhaust systems.
3. Piping Hangers and Isolation. Isolation hangers shall be used for all piping in mechanical rooms and adjacent spaces, up to a 50 ft distance from vibrating equipment. The pipe hangers closest to the equipment shall have the same deflection characteristics as the equipment isolators. Other hangers shall be spring hangers with 0.75 in deflection. Positioning hangers shall be specified for all piping 8 in and larger throughout the building. Spring and rubber isolators are recommended for piping 2 inches and larger hung below noise sensitive spaces.
4. Floor supports for piping may be designed with spring mounts or rubber pad mounts. For pipes subject to large amounts of thermal movement, plates of Teflon or graphite shall be installed above the isolator to permit horizontal sliding.
5. Anchors and guides for vertical pipe risers usually must be attached rigidly to the structure to control pipe movement. Flexible pipe connectors shall be designed into the piping before it reaches the riser.
6. Provide channel supports for multiple pipes and heavy duty steel trapezes to support multiple pipes. Hanger and support schedule shall have manufacturer's number, type and location. Comply with MSS SP69 for pipe hanger selections. Spring hangers and supports shall be provided in all the mechanical rooms.
7. Horizontal Pipe in Mechanical Rooms: Horizontal pipe in mechanical rooms, after the first three hangers, is to be evaluated for possible vibration isolation. The Engineer is to determine if vibration isolation is required, based on the specific application. If continued vibration isolation is warranted, then the hanger shall be of the steel spring and neoprene element in series.

Product Standards:

1. Preferred manufacturers:
 - a. Mason Industries
 - b. Vibration Eliminator Company, Inc.
 - c. Factory installed by HVAC equipment manufacturers.

Performance Standards:

1. Vibration isolation shall be specified, as required, to reduce vibration and noise transmission.
2. The requirements and recommendations as described in the sound and vibration control chapter of the ASHRAE Handbook HVAC Applications and other recognized industry standards shall be used as the basis of design for vibration isolation.
3. State criteria for maximum allowable equipment vibration. State type and deflection of each vibration isolator. This shall apply to all rotating equipment. The type of vibration isolator and the minimum static deflection shall be specified. In addition, the selection shall be based on location and type of equipment.

23 05 53 Identification for HVAC Piping and Equipment**Design Standards:**

1. All mechanical equipment and devices shall be clearly identified using the different methods described on section 230553 of the mechanical specifications. The identifications shall be permanent and a description of each equipment tag shall be described in the maintenance facility log.

Product Standards:

1. Metal Labels for Equipment:
 - a. Material and Thickness: Brass, 0.032-inch (0.8-mm), Stainless steel, 0.025-inch (0.64-mm) or anodized aluminum, 0.032-inch (0.8-mm) minimum thickness, and having predrilled or stamped holes for attachment hardware.
 - b. Minimum Label Size: Length and width vary for required label content, but not less than 2-1/2 by 3/4 inch (64 by 19 mm).
 - c. Minimum Letter Size: 1/4 inch (6.4 mm) for name of units if viewing distance is less than 24 inches (600 mm), 1/2 inch (13 mm) for viewing distances up to 72 inches (1830 mm), and proportionately larger lettering for greater viewing distances. Include secondary lettering two-thirds to three-fourths the size of principal lettering.
 - d. Fasteners: Stainless-steel rivets or self-tapping screws.
 - e. Adhesive: Contact-type permanent adhesive, compatible with label and with substrate.

2. Plastic Labels for Equipment:
 - a. Material and Thickness: Multilayer, multicolor, plastic labels for mechanical engraving, 1/8 inch (3.2 mm) thick, and having predrilled holes for attachment hardware.
 - b. Letter Color: White.
 - c. Background Color: Black.
 - d. Maximum Temperature: Able to withstand temperatures up to 160 deg F (71 deg C).
 - e. Minimum Label Size: Length and width vary for required label content, but not less than 2-1/2 by 3/4 inch (64 by 19 mm).
 - f. Minimum Letter Size: 1/4 inch (6.4 mm) for name of units if viewing distance is less than 24 inches (600 mm), 1/2 inch (13 mm) for viewing distances up to 72 inches (1830 mm), and proportionately larger lettering for greater viewing distances. Include secondary lettering two-thirds to three-fourths the size of principal lettering.
 - g. Fasteners: Stainless-steel rivets or self-tapping screws.
 - h. Adhesive: Contact-type permanent adhesive, compatible with label and with substrate.
3. Label Content: Include equipment's Drawing designation or unique equipment number, Drawing numbers where equipment is indicated (plans, details, and schedules), plus the Specification Section number and title where equipment is specified.
4. Equipment Label Schedule: for each item of equipment to be labeled, on 8-1/2-by-11-inch (A4) bond paper. Tabulate equipment identification number and identify Drawing numbers where equipment is indicated (plans, details, and schedules), plus the Specification Section number and title where equipment is specified. Equipment schedule shall be included in operation and maintenance data.

23 05 93 Testing, Adjusting, and Balancing for HVAC

Design Standards:

1. The Testing and Balancing contractor shall have up to date certification by Associated Air Balance Council (AABC), the National Environmental Balance Bureau (NEBB), or the Testing, Adjusting, and Balancing Bureau (TABB).
2. The A/E shall specify that factory representatives be present for startup of all major equipment, such as boilers, chillers, air-handling units, packaged pump systems, and automatic control systems.
3. Include in the Testing, Adjusting and Balancing Section of the specification, a subsection for vibration isolation acceptance tests. Detail the tests that will confirm the successful design and the proper installation of the specified equipment.

Product Standards:

1. The test and balance report shall contain detailed information of the project including testing and balance procedures for each type of system, description of measurement devices and instruments used for each parameter, final results and recommendations for system improvements.

Performance Standards:

1. A/E to specify performance testing of all systems and equipment including chillers, boilers, air-handling units, exhaust fans, water heaters, and other systems for part load and full load as per the schedules specified by the designer.
2. Ductwork Pressure and Leak Testing. Tests shall be conducted at static pressures equal to maximum design pressure of system and maximum leakage allowable shall not exceed 50 percent of that allowed in SMACNA's HVAC Air Duct Leakage Manual.
3. Piping and Equipment Pressure and Leak Testing. Leak testing shall be conducted at static pressures as required by code (or as 120 percent of maximum design working pressure of system where no code requirement exists), with maximum permissible leakage.
4. All systems shall be operating within +/- 10% of the specified design parameters.

23 07 00 HVAC Insulation**Design Standards:**

1. Insulation shall be provided in accordance with ASHRAE Standard 90.1 and Florida Energy Code. Insulation that is subject to damage or reduction in thermal resistivity if wetted shall be enclosed with a vapor seal (such as a vapor barrier jacket). All supply air ducts must be insulated and shall have a vapor barrier jacket. The insulation shall cover the duct system with a continuous, unbroken vapor seal.
2. Insulation is required for all return air systems.
3. Insulation of exhaust air systems needs to be evaluated for each project and for each system to guard against condensation formation and heat gain/loss on a recirculating or heat recovery system.
4. All exposed ductwork shall have sealed canvas jacketing. All concealed ductwork shall have foil face jacketing.
5. All duct insulation requiring a more finished appearance and/or requiring protection from damage (such as ductwork in Equipment Rooms within seven feet of the floor) shall be additionally covered with a continuous layer of pre-sized 8 oz. fiberglass cloth applied with fire resistive mastic.

6. Piping Insulation
 - a. All piping systems must be insulated in accordance with ASHRAE Standard 90.1.
 - b. All piping systems with surface temperatures below the average dew point temperature of the indoor ambient air and where condensate drip will cause damage or create a hazard shall be insulated with a vapor barrier to prevent condensation formation regardless as to whether piping is concealed or exposed. Chilled water piping systems shall be insulated with non-permeable insulation (of perm rating 0.00) such as cellular glass. All exposed and concealed piping shall have PVC jacketing.
 - c. Insulated piping lines running outdoors shall have corrugated or plain 0.016 in. aluminum jacket complete with integral longitudinal Pittsburgh seam and butt joint strips to lock out the weather. In addition to the vapor barrier, this jacket is required on cold lines.
 - d. Underground pipe insulation shall have a continuous fiber-reinforced plastic (FRP-60 mils minimum thickness) applied directly over the cellular glass or polyurethane insulation on all straight pipe and fittings. FRP jacket shall form a complete monolithic vapor/weather barrier for the entire underground piping system
 - e. Gauge cocks, temperature sensing wells, strainer caps and blow-down valves, etc., shall be insulated with carefully fitted foamed plastic insulation vapor sealed at all joints and ends.
 - f. Whenever a manufacturer offers customized foam plastic insulation for their equipment, the contractor must use this option. All serviceable items shall have removable caps or plugs that have tight fit and can be removed as required without disturbing permanent adjacent insulation. All foamed plastic insulation exposed to the weather and exposed in mechanical equipment rooms shall be painted with two coats of white latex paint. Refer to Standard Detail for strainer insulation.

Product Standards:

1. Duct Insulation preferred manufacturers:
 - a. CertainTeed Corp.; SoftTouch Duct Wrap.
 - b. Johns Manville; Microlite.
 - c. Knauf Insulation; Friendly Feel Duct Wrap.
 - d. Manson Insulation Inc.; Alley Wrap.
 - e. Owens Corning; SOFTR All-Service Duct Wrap.
2. Piping Insulation preferred manufacturers:
 - a. Aeroflex USA, Inc.; Aerocel.
 - b. Armacell LLC; AP Armaflex.
 - c. K-Flex USA; Insul-Lock, Insul-Tube, and K-FLEX LS.

Performance Standards:

1. All insulation materials shall comply with the fire and smoke hazard ratings (25 for flame spread; 50 for smoke developed) as indicated by ASTM-E84, NFPA 255 and UL 723. Accessories such as adhesives, mastics, cements and tapes shall have the same or better fire and smoke hazard ratings

23 08 00 Commissioning of HVAC**Design Standards:**

1. List the project-specific items of Mechanical equipment and systems to be commissioned.
2. List applicable standards and codes that apply to the commissioning of the equipment and systems commissioned in this section.
3. List other sections of the specifications that relate to the commissioning work of this section, and require coordination and cooperation by Contractor and all subcontractors.
4. As a minimum, the following commissioning tasks will require the cooperation, labor, materials and assistance from the Contractor and subcontractors:
 - a. Mechanical equipment installation verification
 - b. Mechanical system and equipment startup testing, adjusting and calibration
 - c. Mechanical Systems Functional Performance Testing

Product Standards:

1. Sample forms/Reports: Provide adequately detailed sample forms, checklists and report formats for all commissioning inspections, tests and reports which require the cooperation and assistance of the Contractor and subcontractors for completion.

Performance Standards:

1. Test Procedures: Provide adequately detailed test procedures for all commissioning pre-functional and functional performance tests and inspections, which require the cooperation and assistance of the Contractor and subcontractors for completion.
2. Testing and Re-Testing: Require that the Contractor and subcontractors provide all required assistance, labor, materials and supplies for specified commissioning tests. Specify that tests failed due to improper Contractor work or preparation shall be rescheduled, and all costs of re-testing will be borne by the Contractor.
3. Project Closeout: Specify that the Contractor is responsible for the satisfactory completion of all commissioning items of this section, and of Division 1 – General Commissioning Requirements, prior to approval of project closeout.

23 09 00 Instrumentation and Control for HVAC**Design Standards:**

1. Comply with ASHRAE 135 for DDC system components.

Product Standards:

1. DDC Equipment:
 - a. Operator Workstation: Microcomputer with printer.
 - b. Printer: Black-and-white, laser-jet type.
 - c. Application Software: With dynamic color graphic displays, alarm and event processing, automatic restart, and data collection.
 - d. Diagnostic Terminal Unit: Portable notebook-style microcomputer.
 - e. Control Units: Modular, comprising processor board with programmable, nonvolatile, random-access memory; local operator access and display panel; integral interface equipment; and backup power source.
 - f. Local Control Units: Modular, comprising processor board with electronically programmable, nonvolatile, read-only memory; and backup power source.
 - g. Hardwired I/O interface.
 - (1) Power supplies.
 - (2) Power line filtering.
 - h. Unitary Controllers: Unitized, capable of stand-alone operation with sufficient memory to support its operating system, database, and programming requirements, and with sufficient I/O capacity for the application.
 - i. Alarm Panels: Unitized cabinet with suitable brackets for wall or floor mounting. Indicating light for each alarm point, single horn, acknowledge switch, and test switch, mounted on hinged cover.
 - j. Analog Controllers:
 - (1) 6- or 10-stage-type step controllers.
 - (2) Remote-bulb or bimetal rod-and-tube-type, electric outdoor-reset controllers.
 - (3) Wheatstone-bridge-amplifier-type electronic controllers.
 - (4) Solid-state fan-speed controllers.
 - (5) Single- or multiple-input receiver controllers.
 - k. Time Clocks: Solid-state, programmable time control with separate programs.
 - l. Electronic Sensors: Wall, immersion, or duct mounting.
 - (1) Thermistor temperature sensors and transmitters.
 - (2) RTDs and transmitters.
 - (3) Humidity sensors.
 - (4) Pressure transmitters/transducers.
 - m. Status Sensors:
 - (1) Status inputs for fans.
 - (2) Status inputs for pumps.
 - (3) Status inputs for electric motors.

- (4) Voltage transmitters (100- to 600-V ac).
- (5) Power monitors.
- (6) Current switches.
- (7) Electronic valve/damper position indicators.
- (8) Water-flow switches.
- n. Gas Detection Equipment:
 - (1) Carbon monoxide detectors.
 - (2) Carbon dioxide sensor and transmitters.
 - (3) Oxygen sensor and transmitters.
 - (4) Occupancy sensors.
- o. Duct airflow station
- p. Thermostats:
 - (1) Combination thermostat and fan switches.
 - (2) Electric, solid-state, microcomputer-based room thermostats.
 - (3) Low-voltage, on-off thermostats.
 - (4) Line-voltage, on-off thermostats.
 - (5) Remote-bulb thermostats.
 - (6) Fire-protection thermostats.
 - (7) Immersion thermostats.
 - (8) Airstream thermostats.
 - (9) Electric, low-limit duct thermostats.
 - (10) Electric, high-limit duct thermostats.
 - (11) Heating/cooling valve-top thermostats.
- q. Humidistats: Duct-mounting and pneumatic duct-mounting type.
- r. Actuators:
 - (1) Electric motors.
 - (2) Electronic actuators.
- s. Control Valves:
 - (1) Globe Valves:
 - (a) NPS 2 and Smaller: Class 125 bronze body, bronze trim, rising stem, renewable composition disc, and screwed ends with backseating capacity repackable under pressure.
 - (b) NPS 2-1/2 and Larger: Class 125 iron body, bronze trim, rising stem, plug-type disc, flanged ends, and renewable seat and disc.
 - (c) Internal Construction: Replaceable plugs and stainless-steel or brass seats.
 - (1.) Single-Seated Valves: Cage trim provides seating and guiding surfaces for plug on top and bottom.
 - (2.) Double-Seated Valves: Balanced plug; cage trim provides seating and guiding surfaces for plugs on top and bottom.
 - (d) Sizing: 3-psig maximum pressure drop at design flow rate or the following:
 - (1.) Two Position: Line size.
 - (2.) Two-Way Modulating: Either the value specified above or twice the load pressure drop, whichever is more.

- (3.) Three-Way Modulating: Twice the load pressure drop, but not more than value specified above.
- (e) Flow Characteristics: Two-way valves shall have equal percentage characteristics; three-way valves shall have linear characteristics.
- (f) Close-Off (Differential) Pressure Rating: Combination of actuator and trim shall provide minimum close-off pressure rating of 150 percent of total system (pump) head for two-way valves and 100 percent of pressure differential across valve or 100 percent of total system (pump) head.
- (2) Butterfly Valves:
200-psig, 150-psig maximum pressure differential, ASTM A 126 cast-iron or ASTM A 536 ductile-iron body and bonnet, extended neck, stainless-steel stem, field-replaceable EPDM or Buna N sleeve and stem seals.
 - (a) Body Style: Wafer, Lug or Grooved.
 - (b) Disc Type: Nickel-plated ductile iron, Aluminum bronze, or Elastomer-coated ductile iron.
 - (c) Sizing: 1-psig maximum pressure drop at design flow rate.
- (3) Terminal Unit Control Valves (Heating Hot Water Reheat Systems Only):
Bronze body, bronze trim, two or three ports as indicated, replaceable plugs and seats, and union and threaded ends.
 - (a) Rating: Class 125 for service at 125 psig and 250 deg F operating conditions.
 - (b) Sizing: 3-psig maximum pressure drop at design flow rate, to close against pump shutoff head.
 - (c) Flow Characteristics: Two-way valves shall have equal percentage characteristics; three-way valves shall have linear characteristics.
- (4) Self-Contained Control Valves:
Bronze body, bronze trim, two or three ports as indicated, replaceable plugs and seats, and union and threaded ends.
 - (a) Rating: Class 125 for service at 125 psig and 250 deg F operating conditions.
 - (b) Thermostatic Operator: Liquid-filled integral sensor with remote adjustable dial.
- t. Dampers: AMCA-rated, opposed-blade design, for standard-pressure and low-leak applications.
- u. Air Supply:
 - (1) Tank: ASME storage tank.
 - (2) Refrigerated air dryers.
 - (3) Desiccant dryers.
 - (4) Pressure gages.

- (5) Instrument pressure gages.
- (6) Diaphragm control and instrument valves.
- (7) Gage cocks.
- (8) Relays.
- (9) Switches.
- (10) Pressure regulators.
- (11) Particle filters.
- (12) Combination filter/regulators.
- (13) Airborne oil filters.
- (14) Pressure relief valves.

23 09 93 Sequence of Operations for HVAC Controls

Design Standards:

1. The sequence of operations must define the manner and method by which HVAC equipment functions. The sequence of operation shall be designed to be implemented using the instrumentation and controls for HVAC systems specified on section 230900.
2. Sequence of operations shall be included on design drawings rather than on specifications.
3. Sequence of operations shall be accompanied by control diagrams and written description.

Product Standards:

Not applicable

Performance Standards:

1. The sequence of operation must be capable to execute the actions to be done by all mechanical equipment and coordinate their interaction without deviations of the design intent.

23 11 13 Facility Fuel-Oil Piping

Design Standards:

1. Pressurized fuel oil piping must have an automatic leak detection method. Leak detection system shall meet the requirements of EPA.
2. Fuel-Oil piping corrosion protection shall be provided to lessen or prevent the deterioration of the piping system from exposure to its contents or its environment.

3. Pipe sizing should be based on the flow rate of the product, the allowable friction loss of the fluid through the system, and the fluid velocity.
4. Piping material chosen shall be compatible with the liquids being handled.
5. Pipe should be installed in a flat and level trench, far enough underground to prevent vehicular damage.
6. For pressurized piping, use a minimum of a 2-inch size.
7. Restraint and anchors for fuel-oil piping, ASTs, and equipment, shall be designed based on performance requirements.
8. Piping system shall contain valves to operate the system properly and to isolate the equipment in the event of an emergency.
9. Piping system in connection with pumps shall contain valves to properly control the flow of liquid both in normal operation and in the event of an emergency.
10. Fuel tanks shall be aboveground on-site tanks, protected with concrete filled bollards at new facilities. Comply with NFPA 58 for locations.
 - a. Facilities requiring the replacement or relocation of fuel tanks, shall receive aboveground fuel tanks.
 - b. New underground or relocated underground fuel oil tanks are not allowed.
 - c. Locate fuel tanks as far as possible from student occupied areas.
 - d. Aboveground fuel oil lines shall be painted.

Product Standards:

1. Steel Pipe: ASTM A 53/A 53M, black steel, Schedule 40, Type E or S, Grade B.
2. Drawn-Temper Copper Tube: Comply with ASTM B 88, Type K
3. Annealed-Temper Copper Tube: Comply with ASTM B 88, Type K

Performance Standards:

1. The design, fabrication, assembly, testing, and inspection of piping system shall be suitable for the working pressures and structural stresses to be encountered by the piping system.
2. Maximum Operating-Pressure Ratings: 3-psig fuel-oil supply pressure at oil-fired appliances.
3. Piping must be tested hydrostatically at a pressure of 100 psig for a period of 30 minutes with no leakage allowed.

23 11 23 Facility Natural-Gas Piping**Design Standards:**

1. Gas service available to students shall be provided with clearly labeled master emergency shut-offs.
2. Install detectable warning tape directly above gas piping, 12 inches below finished grade. Install at 6 inches below subgrade under pavements and slabs.
3. Engineering plans shall show the proposed location of piping, the size of different branches, the various load demands, and the location of the point of delivery.
4. When additional appliances are being connected to a gas piping system, the existing piping shall be checked to determine whether it has adequate capacity.
5. Gas meter and regulators shall be located in ventilated spaces readily accessible for examination, reading, replacement, or necessary maintenance.
6. Gas piping in contact with earth or other material that could corrode the piping shall be protected against corrosion in an approved manner.
7. Piping in systems shall be run as directly as is practical from one point to another, with as few fittings as practical.
8. Prohibited Locations:
 - a. Do not install natural-gas piping in or through circulating air ducts, clothes or trash chutes, chimneys or gas vents (flues), ventilating ducts, or dumbwaiter or elevator shafts.
 - b. Do not install natural-gas piping in solid walls or partitions.
 - c. Gas lines shall not be installed in student residential areas.
 - d. Gas meter and regulators shall not be placed where they will be subjected to damage, such as adjacent to a driveway, under a fire escape, in public passages, halls, or coal bins, or where they will be subject to excessive corrosion or vibration.
 - e. Gas lines shall not be installed below slabs or in return air plenums.
9. Gas piping shall not be used as a grounding conductor or electrode.
10. Where a lighting protection system is installed, the bonding of the gas piping shall be in accordance with NFPA 780.
11. Gas piping installation shall meet all requirements of NFPA 54.

Product Standards:

1. Steel Pipe: ASTM A 53/A 53M, black steel, Schedule 40, Type E or S, Grade B.
2. Corrugated, Stainless-Steel Tubing: Comply with ANSI/IAS LC 1.
3. Preferred manufacturers:
 - a. OmegaFlex, Inc.
 - b. Parker Hannifin Corporation; Parflex Division.
 - c. Titeflex.
 - d. Tru-Flex Metal Hose Corp.
4. Cast iron pipe shall not be used.

Performance Standards:

1. Minimum Operating-Pressure Ratings:
 - a. Piping and Valves: 100 psig minimum unless otherwise indicated.
2. Gas piping system shall be of such size and so installed as to provide a supply of gas sufficient to meet the maximum demand and supply gas to each appliance inlet at not less than the minimum supply pressure required by the appliance.

23 11 26 Facility Liquefied-Petroleum Gas Piping**Design Standards:**

1. Gas service available to students shall be provided with clearly labeled master emergency shut-offs.
2. Install detectable warning tape directly above gas piping, 12 inches below finished grade. Install at 6 inches below subgrade under pavements and slabs.
3. Engineering plans shall show the proposed location of piping, the size of different branches, the various load demands, and the location of the point of delivery.
4. When additional appliances are being connected to a gas piping system, the existing piping shall be checked to determine whether it has adequate capacity.
5. Gas piping in contact with earth or other material that could corrode the piping shall be protected against corrosion in an approved manner.
6. Piping in systems shall be run as directly as is practical from one point to another, with as few fittings as practical.
7. Prohibited Locations:

- a. Do not install gas piping in or through circulating air ducts, clothes or trash chutes, chimneys or gas vents (flues), ventilating ducts, or dumbwaiter or elevator shafts.
 - b. Do not install gas piping in solid walls or partitions.
 - c. Gas lines shall not be installed in student residential areas.
 - d. Do not install gas piping below slabs or in return air plenums.
8. Gas piping shall not be used as a grounding conductor or electrode.
 9. Where a lighting protection system is installed, the bonding of the gas piping shall be in accordance with NFPA 780.
 10. All gas piping shall meet the requirements of NFPA 54.

Product Standards:

1. Steel Pipe: ASTM A 53/A 53M, black steel, Schedule 40, Type E or S, Grade B.
2. Corrugated, Stainless-Steel Tubing: Comply with ANSI/IAS LC 1.
3. Preferred manufacturers:
 - a. OmegaFlex, Inc.
 - b. Parker Hannifin Corporation; Parflex Division.
 - c. Titeflex.
 - d. Tru-Flex Metal Hose Corp.
4. Cast iron pipe shall not be used.

Performance Standards:

1. Gas piping system shall be of such size and so installed as to provide a supply of gas sufficient to meet the maximum demand and supply gas to each appliance inlet at not less than the minimum supply pressure required by the appliance.
2. Minimum Operating-Pressure Ratings:
 - a. Piping containing only vapor: 125 psig minimum unless otherwise indicated.
 - b. For Piping Containing Liquid:
 - (1) Piping between Shutoff Valves: 350 psig unless otherwise indicated.
 - (2) Piping Other Than Above: 250 psig unless otherwise indicated.
 - (3) Valves and Fittings: 250 psig unless otherwise indicated.

23 21 13 Hydronic Piping**Design Standards:**

1. Piping shall conform to applicable ASTM standards.

Product Standards:

Piping Applications

1. Hot-water heating piping, aboveground, NPS 2 and smaller, shall be the following:
 - a. Type L (B), drawn-temper copper tubing, wrought-copper fittings, and soldered joints.
 - b. Schedule 40 steel pipe; Class 150, malleable-iron fittings; and threaded joints.
2. Hot-water heating piping, aboveground, NPS 2-1/2 and larger, shall be the following:
 - a. Schedule 40 steel pipe, wrought-steel fittings and wrought-cast or forged-steel flanges and flange fittings, and welded and flanged joints.
3. Hot-water heating piping installed below ground and within slabs shall be the following:
 - a. Type K annealed-temper copper tubing, wrought-copper fittings, and soldered joints. Use the fewest possible joints and offsets.
4. Chilled-water piping, aboveground, NPS 2 and smaller, shall be the following:
 - a. Schedule 40 steel pipe; Class 150, malleable fittings and threaded joints.
5. Chilled-water piping, aboveground, NPS 2-1/2 and larger, shall be the following:
 - a. Schedule 40 steel pipe, wrought-steel fittings and wrought-cast or forged-steel flanges and flange fittings, and welded and flanged joints
6. Chilled-water piping installed belowground and within slabs shall be either of the following:
 - a. Schedule 40 steel pipe; Class 150, malleable-iron fittings; forged-steel flanges and flange fittings; and threaded joints. Piping shall be pre-insulated with 3" thick polyurethane with FRP or PVC jacket.
7. Makeup-water piping installed aboveground shall be the following:
 - a. Type L (B), drawn-temper copper tubing, wrought-copper fittings, and soldered joints.
8. Makeup-Water Piping Installed below ground and within Slabs: Type K, annealed temper copper tubing, wrought-copper fittings, and soldered joints. Use the fewest possible joints.

Performance Standards:

1. Hydronic piping components and installation provided shall be capable of withstanding minimum working pressure and temperature requirements according to the application.
2. Minimum working pressure and temperature requirements for hydronic piping components and installation are the following:
 - a. Hot-Water Heating Piping: 150 psig at 200 deg F (93 deg C).
 - b. Chilled-Water Piping: 150 psig at 200 deg F (93 deg C).
 - c. Makeup-Water Piping: 100 psig at 150 deg F.

23 21 23 Hydronic Pumps**Design Standards:**

1. Pumps shall be of a centrifugal type (End-Suction, Split-Case, Vertical In-line) and shall generally be selected to operate at 1750 RPM. Both partial load and full load must fall on the pump curve. The specified pump motors shall not overload throughout the entire range of the pump curve.

Product Standards:

1. Individual pumps serving variable flow systems with a head value exceeding 100 ft and motor exceeding 50 hp shall have controls and/or devices (such as variable speed control) that will result in pump motor demand of no more than 30% of design wattage at 50% of design water flow. Variable volume pumping shall be considered for all piping systems.
2. Preferred Manufacturers:
 - a. Bell & Gossett
 - b. Taco, Inc.
 - c. Armstrong Pumps Inc.

Performance Standards:

1. The pump shall be selected to operate in the best efficiency region of the curve.

23 23 00 Refrigerant Piping**Design Standards:**

1. Refrigerant piping shall comply with ASTM 88 Standard B280, ASHRAE 15, "Safety Code for Refrigeration Systems" and ASME B31.5, "Refrigeration Piping and Heat Transfer Components".

2. Refrigerant piping lines shall be the following according to the application:
 - a. Suction Lines NPS 1-1/2 and Smaller for Conventional Air-Conditioning Applications: Copper, Type ACR, annealed-temper tubing and wrought-copper fittings with brazed joints.
 - b. Suction Lines NPS 2 to NPS 4 for Conventional Air-Conditioning Applications: Copper, Type L (B), drawn-temper tubing and wrought-copper fittings with brazed or soldered joints.
 - c. Hot-Gas and Liquid Lines, and Suction Lines for Heat-Pump Applications: Copper, Type ACR, annealed-temper tubing and wrought-copper fittings with brazed or soldered joints.
 - d. Hot-Gas and Liquid Lines, and Suction Lines for Heat-Pump Applications: Copper, Type K or L (B), drawn-temper tubing and wrought-copper fittings with soldered joints.
 - e. Hot-Gas and Liquid Lines, and Suction Lines for Heat-Pump Applications:
 - (1) NPS 1-1/2 and Smaller: Copper, Type ACR, annealed-temper tubing and wrought-copper fittings with brazed or soldered joints.
 - (2) NPS 1-1/2 and Smaller: Copper, Type ACR L (B), drawn-temper tubing and wrought-copper fittings with brazed or soldered joints.
 - (3) NPS 2 to NPS 3: Copper, Type K (A), annealed- or drawn-temper tubing and wrought-copper fittings with brazed or soldered joints.
 - (4) NPS 4: Copper, Type K (A) or L (B), drawn-temper tubing and wrought-copper fittings with soldered joints.
3. Refrigerant piping shall be installed in accordance with ASHRAE standards. Refrigerant piping shall be insulated in accordance with ASHRAE Standard 90.1 6.4.4.1.3.
4. Nitrogen purging shall be provided during brazing. Piping shall be supported every 6-feet. A line size trap shall be provided every 25 feet of vertical lift.

Product Standards:

1. Preferred manufacturer for refrigerant piping: US Manufacturers

Performance Standards:

1. Line Test Pressure for Refrigerant R-134a:
 - a. Suction Lines for Air-Conditioning Applications: 115 psig.
 - b. Suction Lines for Heat-Pump Applications: 225 psig.
 - c. Hot-Gas and Liquid Lines: 225 psig.
2. Line Test Pressure for Refrigerant R-410A:
 - a. Suction Lines for Air-Conditioning Applications: 300 psig.
 - b. Suction Lines for Heat-Pump Applications: 535 psig.
 - c. Hot-Gas and Liquid Lines: 535 psig.

23 25 00 HVAC Water Treatment**Design Standards:**

1. The water treatment for all hydronic systems shall be designed by a qualified specialist. The design system shall address the three aspects of water treatment: biological growth, dissolved solids and scaling, and corrosion protection.
2. The methods used to treat the systems' make-up water shall have prior success in existing facilities on the same municipal water supply and follow the guidelines outlined in ASHRAE Applications Handbook.

Product Standards:

1. The system shall operate with an injection pump transferring chemicals from solution tank(s) as required to maintain the conditions described. The chemical feed system shall have BACnet self-contained controls.
2. Preferred Manufacturers:
 - a. Filtration Systems Division of Mechanical Mfg. Corporation
 - b. Miami Filters LLC
 - c. Ecolochem

Performance Standards:

1. The performance of the water treatment systems shall produce, as a minimum, the following characteristics; hardness: 0.00; iron content: 0.00; dissolved solids: 1,500 to 1,750 ppm; silica: 610 ppm or less; and a PH of 10.5 or above.

23 31 13 Metal Ducts**Design Standards:**

1. Low-pressure supply ductwork shall be sized for a static pressure drop of 0.08 inch water gage per 100 feet up to 2500 cfm and for a velocity of 1200 fpm above 2500 cfm. Low-velocity return and exhaust ductwork shall be sized for a static pressure drop of 0.08 inch water gage per 100 feet up to 4000 cfm and for a velocity of 1000 fpm above 4000 cfm.
2. Medium and high pressure supply ductwork shall be sized for a static pressure drop of 0.3 inch water per 100 feet. Air velocity shall not exceed 2000 fpm.
3. Special duct systems such as exhaust from laboratory hoods shall be made of acid resistant construction and/or coatings.

4. Duct systems serving showers and other spaces of high humidity shall be of aluminum construction.
5. Specify on plans minimum SMACNA duct construction pressure classification for all systems.

Product Standards:

1. Duct leakage rates, construction, including sheet metal thicknesses, seam and joint construction, reinforcements and hangers and supports shall comply with SMACNA's "HVAC Duct Construction Standards- Metal and Flexible". Latest Edition.

23 31 19 HVAC Casings**Design Standards:**

1. Factory-fabricated, field-assembled, double-wall casings shall be provided for HVAC equipment.
2. HVAC casing material shall comply with SMACNA's "HVAC Duct Construction Standards- Metal and Flexible," Chapter 6, "Equipment and Casings", for acceptable materials, material thicknesses, and casing construction methods. Casings shall be fabricated with more than 3-inch wg negative static pressure according to SMACNA's "Rectangular Industrial Duct Construction Standards." Casings with more than 2-inch wg positive static pressure may be fabricated according to SMACNA's "Rectangular Industrial Duct Construction Standards."
3. Double-wall, insulated, pressurized equipment casings shall be used. Casings shall consist of a solid, galvanized sheet steel exterior wall and solid, galvanized sheet steel interior wall with space between wall filled with insulation. Wall thickness shall be 2 inches. Sheet metal exterior and interior minimum wall thicknesses shall be 0.040 inch and 0.034 inch, respectively.
4. Access doors shall be fabricated as per SMACNA's "HVAC Duct Construction Standards - Metal and Flexible," and according to pressure class of the plenum or casing section in which access doors are to be installed. Doors shall open against air pressure.

Product Standards:

1. Casing Preferred Manufacturers:
 - a. Acoustical Surfaces, Inc.
 - b. AeroSonics, Inc.; a division of TUTCO, Inc.
 - c. CertainTeed Corp.; Insulation Group.
 - d. CLEANPAK International.
 - e. D&D Sound Control.
 - f. IACL.

- g. Industrial Noise Control, Inc.
- h. McGill AirSilence LLC.
- i. SEMCO Incorporated.
- j. Vibro-Acoustics.

Performance Standards:

1. Static-Pressure Classes:
 - a. Upstream from Fan(s): 2-inch wg.
 - b. Downstream from Fan(s): 4-inch wg.
2. Acoustical Performance:
 - a. NRC: 1.09 according to ASTM C 423.
 - b. STC: 40 according to ASTM E 90.
3. Structural Performance:
 - a. Casings shall be fabricated to withstand 133 percent of the indicated static pressure without structural failure. Wall and roof deflection at the indicated static pressure shall not exceed 1/8 inch per foot of width.
 - b. Fabricate outdoor casings to withstand wind load of 150 lbf/sq. ft

23 33 00 Air Duct Accessories**Design Standards:**

1. Air duct accessories provided shall be suitable for their intended use.
2. Air duct accessories shall comply with NFPA 90A, "Installation of Air Conditioning and Ventilating Systems," and with NFPA 90B, "Installation of Warm Air Heating and Air Conditioning Systems." Air duct accessories shall also comply with SMACNA's "HVAC Duct Construction Standards - Metal and Flexible" for acceptable materials, material thicknesses, and duct construction methods unless otherwise indicated.

Product Standards:

1. Backdraft and Pressure Relief Dampers/ Barometric Relief Dampers Preferred Manufacturers:
 - a. Air Balance Inc.; a division of Mestek, Inc.
 - b. American Warming and Ventilating; a division of Mestek, Inc.
 - c. Cesco Products; a division of Mestek, Inc.
 - d. Duro Dyne Inc.
 - e. Greenheck Fan Corporation.
 - f. Lloyd Industries, Inc.
 - g. Nailor Industries Inc.
 - h. NCA Manufacturing, Inc.
 - i. Pottorff; a division of PCI Industries, Inc.
 - j. Ruskin Company.

- k. SEMCO Incorporated.
 - l. Vent Products Company, Inc.
2. Manual Volume Dampers Preferred Manufacturers:
- a. Air Balance Inc.; a division of Mestek, Inc.
 - b. American Warming and Ventilating; a division of Mestek, Inc.
 - c. Flexmaster U.S.A., Inc.
 - d. McGill AirFlow LLC.
 - e. METALAIR, Inc.
 - f. Nailor Industries Inc.
 - g. Pottorff; a division of PCI Industries, Inc.
 - h. Ruskin Company.
 - i. Trox USA Inc.
 - j. Vent Products Company, Inc
3. Control Dampers Preferred Manufacturers:
- a. American Warming and Ventilating; a division of Mestek, Inc.
 - b. Arrow United Industries; a division of Mestek, Inc.
 - c. Cesco Products; a division of Mestek, Inc.
 - d. Duro Dyne Inc.
 - e. Flexmaster U.S.A., Inc.
 - f. Greenheck Fan Corporation.
 - g. Lloyd Industries, Inc.
 - h. M&I Air Systems Engineering; Division of M&I Heat Transfer Products Ltd.
 - i. McGill AirFlow LLC.
 - j. METALAIR, Inc.
 - k. Metal Form Manufacturing, Inc.
 - l. Nailor Industries Inc.
 - m. NCA Manufacturing, Inc.
 - n. Ruskin Company.
 - o. Vent Products Company, Inc.
 - p. Young Regulator Company.
4. Fire Dampers Preferred Manufacturers:
- a. Air Balance Inc.; a division of Mestek, Inc.
 - b. Arrow United Industries; a division of Mestek, Inc.
 - c. Cesco Products; a division of Mestek, Inc.
 - d. Greenheck Fan Corporation.
 - e. McGill AirFlow LLC.
 - f. METALAIR, Inc.
 - g. Nailor Industries Inc.
 - h. NCA Manufacturing, Inc.
 - i. PHL, Inc.
 - j. Pottorff; a division of PCI Industries, Inc.
 - k. Prefco; Perfect Air Control, Inc.
 - l. Ruskin Company.
 - m. Vent Products Company, Inc.
 - n. Ward Industries, Inc.; a division of Hart & Cooley, Inc.

5. Smoke Dampers Preferred Manufacturers:
 - a. Air Balance Inc.; a division of Mestek, Inc.
 - b. Cesco Products; a division of Mestek, Inc.
 - c. Greenheck Fan Corporation.
 - d. Nailor Industries Inc.
 - e. PHL, Inc.
 - f. Ruskin Company.

6. Combination Fire and Smoke Dampers Preferred Manufacturers:
 - a. Air Balance Inc.; a division of Mestek, Inc.
 - b. Cesco Products; a division of Mestek, Inc.
 - c. Greenheck Fan Corporation.
 - d. Nailor Industries Inc.
 - e. Ruskin Company.

7. Flexible Ducts Preferred Manufacturers:
 - a. Flexmaster U.S.A., Inc.
 - b. McGill AirFlow LLC.
 - c. Ward Industries, Inc.; a division of Hart & Cooley, Inc.

8. Duct Silencers Preferred Manufacturers:
 - a. Dynasonics.
 - b. Industrial Noise Control, Inc.
 - c. McGill AirFlow LLC.
 - d. Ruskin Company.
 - e. Acoustical Solutions
 - f. Vibro-Acoustics
 - g. IAC Acoustics

Performance Standards:

Duct accessories shall be designed for the following working conditions:

1. Backdraft and Pressure Relief Dampers:
 - a. Maximum Air Velocity: 2000 fpm.
 - b. Maximum System Pressure: 2-inch wg.

2. Barometric Relief Dampers:
 - a. Maximum Air Velocity: 2500 fpm.
 - b. Maximum System Pressure: 2-inch wg.

3. Fire Dampers:
 - a. Closing rating in ducts up to 4-inch wg static pressure class and minimum 4000-fpm velocity.

4. Combination Fire and Smoke Dampers:

- a. Closing rating in ducts up to 4-inch wg (1-kPa) static pressure class and minimum 4000-fpm (20-m/s) velocity.
5. Flexible Ducts:
- a. Insulated, Flexible Duct: UL 181, Class 1, 2-ply vinyl film supported by helically wound, spring-steel wire; fibrous-glass insulation; aluminized vapor-barrier film.
 - (1) Pressure Rating: 10-inch wg positive and 1.0-inch wg negative.
 - (2) Maximum Air Velocity: 4000 fpm.
 - (3) Temperature Range: Minus 10 to plus 160 deg F.
 - (4) Insulation R-value: Comply with ASHRAE/IESNA 90.1-2004.
 - b. Insulated, Flexible Duct: UL 181, Class 1, black polymer film supported by helically wound, spring-steel wire; fibrous-glass insulation; aluminized vapor-barrier film.
 - (1) Pressure Rating: 4-inch wg positive and 0.5-inch wg negative.
 - (2) Maximum Air Velocity: 4000 fpm.
 - (3) Temperature Range: Minus 20 to plus 175 deg F.
 - (4) Insulation R-Value: Comply with ASHRAE/IESNA 90.1-2004.
 - c. Insulated, Flexible Duct: UL 181, Class 1, multiple layers of aluminum laminate supported by helically wound, spring-steel wire; fibrous-glass insulation; aluminized vapor-barrier film.
 - (1) Pressure Rating: 10-inch wg positive and 1.0-inch wg negative.
 - (2) Maximum Air Velocity: 4000 fpm.
 - (3) Temperature Range: Minus 20 to plus 210 deg F.
 - (4) Insulation R-value: Comply with ASHRAE/IESNA 90.1-2004.
 - d. Insulated, Flexible Duct: UL 181, Class 1, aluminum laminate and polyester film with latex adhesive supported by helically wound, spring-steel wire; fibrous-glass insulation; aluminized vapor-barrier film.
 - (1) Pressure Rating: 10-inch wg positive and 1.0-inch wg negative.
 - (2) Maximum Air Velocity: 4000 fpm.
 - (3) Temperature Range: Minus 20 to plus 210 deg F.
 - (4) Insulation R-value: Comply with ASHRAE/IESNA 90.1-2004.
 - e. Insulated, Flexible Duct: UL 181, Class 0, interlocking spiral of aluminum foil; fibrous-glass insulation; aluminized vapor-barrier film.
 - (1) Pressure Rating: 8-inch wg positive or negative.
 - (2) Maximum Air Velocity: 5000 fpm.
 - (3) Temperature Range: Minus 20 to plus 250 deg F.
 - (4) Insulation R-value: Comply with ASHRAE/IESNA 90.1-2004.

23 34 23 HVAC Power Ventilators

Design Standards:

1. Select power ventilators to have the operation point at right side of the system curve.
2. Ratings for HVAC power ventilators shall be based on tests and procedures performed in accordance with AMCA Publication 211 and AMCA Publication 311 and comply with the requirements of the AMCA Certified Ratings Program.

3. **Ceiling-Mounted Ventilators**
Centrifugal fan (ceiling-mounted ventilator) shall be designed for installation in ceiling, wall, or concealed inline applications and shall include housing, fan wheel, grille, remote fan speed control, and accessories.
4. **Centrifugal Roof Ventilators**
Belt-driven or direct-drive centrifugal ventilators shall consist of housing, wheel, fan shaft, bearings, motor and disconnect switch, drive assembly, curb base, and accessories (i.e., bird screens, dampers, roof curbs, etc.).
5. **Utility Set Fans**
Belt-driven, centrifugal fans shall consist of housing, wheel, fan shaft, bearings, motor and disconnect switch, drive assembly, and accessories (i.e., backdraft dampers, access doors, etc.).
6. **Axial Roof Ventilators**
Belt-driven or direct-drive, axial fans shall consist of housing, wheel, fan shaft, bearings, motor and disconnect switch, drive assembly, curb base, and accessories (i.e., bird screens, dampers, roof curbs, etc.).
7. **Upblast Propeller Roof Exhaust Fans**
Belt-driven or direct-drive propeller fans shall consist of housing, wheel, butterfly type discharge damper, fan shaft, bearings, motor and disconnect switch, drive assembly, curb base, and accessories.
8. **Centrifugal Wall Ventilators**
Belt-driven or direct-drive centrifugal wall ventilators shall consist of housing, wheel, fan shaft, bearings, motor and disconnect switch, drive assembly, and accessories (i.e., bird screens, dampers, etc.).
9. Any fan whose rotational speed is not controlled by a variable frequency drive shall be equipped with a speed controller.

Product Standards:

1. All air moving devices shall be tested in accordance to ANSI/ASHRAE Standard 51 (ANSI/ACMA Standard 210)
2. The specified power ventilator motors shall not overload throughout the entire range of the system curve.
3. Preferred Manufacturers:
 - a. Loren Cook
 - b. Greenheck

Performance Standards:

1. Fans shall be factory fabricated and assembled, factory tested, and factory finished with indicated capacities and characteristics. Fans and shafts shall be statically and dynamically balanced. Fans shall be designed for continuous operation at the maximum rated fan speed and motor horsepower.
2. Fans and ventilators to be installed outdoors shall be designed to withstand a wind load of 150 lbf/sq. ft.

23 36 00 Air Terminal Units**Design Standards:**

1. Terminal units shall be pressure independent.
2. Terminal units shall be selected so that design air volume is approximately three-quarters of the terminal box's maximum capacity. Air terminal units shall be single-duct, shut-off type.
3. Volume dampers in terminal units shall be located at least 1.6 ft from the closest diffuser and the use of grille mounted balance dampers shall be restricted except for those applications with accessibility problems.
4. Terminal units shall be equipped with supply air temperature sensor and air flow measuring device.

Product Standards:

1. Preferred Manufacturers:
 - a. Titus
 - b. Trane
 - c. Envirotec

Performance Standards:

1. Terminal units shall provide the minimum and maximum air flows indicated on design documents within 10%.

23 37 13 Diffusers, Registers, and Grilles**Design Standards:**

1. Air Distribution Terminal Devices shall be designed and selected so as to integrate well into the architectural features of the ceilings, walls and soffits.

Product Standards:

1. Preferred Manufacturers
 - a. Titus
 - b. Price
 - c. Anemostat
 - d. Krueger

Performance Standards:

1. Design parameters to be considered are adequate “throw”, avoidance of “drafts”, sufficient air quantities for the space covered, and maximum separation between supply and return terminals. The following are basic terminal devices suitable for most applications:
 - a. Rectangular and square ceiling diffusers.
 - b. Ceiling linear diffuser, single or multiple slots.
 - c. Sidewall register.
 - d. Louvered or “egg-crate” ceiling return grille
 - e. Ceiling linear return, single or multiple slots.
 - f. Sidewall return grille.
2. Diffusers, registers and grilles used in variable-air-volume flow air distribution systems shall be suitable for this use..
3. All supply air grilles, registers and ceiling outlets shall be aluminum.
4. All sidewall supply grilles and registers shall be double deflection type.
5. Multi-blade volume control dampers which are adjustable by removable key from the front of each outlet shall be provided for all air distribution devices.

23 37 23 HVAC Gravity Ventilators**Design Standards:**

1. Coordinate sizes and locations of roof curbs, equipment supports, and roof penetrations with architect and structural engineer.
2. Neck velocities shall not exceed 700 feet per minute.
3. Gravity ventilators shall be provided with bird screens.

Product Standards:

1. Preferred Manufacturers:
 - a. Carnes
 - b. Greenheck

- c. JencoFan
- d. Loren Cook

Performance Standards:

1. HVAC gravity ventilators shall withstand the effects of gravity loads and wind loads within limits and under conditions indicated without permanent deformation of ventilator components, noise or metal fatigue caused by ventilator blade rattle or flutter, or permanent damage to fasteners and anchors. Wind pressures shall be considered to act normal to the face of the building.
2. HVAC gravity ventilators shall also allow for thermal movements from ambient and surface temperature changes, without buckling, opening of joints, overstressing of components, failure of connections, or other detrimental effects. Temperature change (range) to be considered shall be 120 deg F, ambient and 180 deg F, material surfaces.

23 41 00 Particulate Air Filtration**Design Standards:**

1. Particulate air filtration shall be provided in air-handling units. A pre-filter and a final filter shall be provided upstream of the air-handling unit cooling and heating coils. Fibrous shedding of the filter media shall not exceed levels prescribed by ASHRAE Standard 52.2-2007. 0.5 percent of the design supply airflow rate shall be considered as the maximum bypass leakage air around the filter media in the design of filter racks. A maximum face velocity of 500 fpm shall be used for filter sizing. The filter housing and air-handling unit components downstream of the filter housing shall not be internally lined with fibrous insulation. An externally insulated sheet metal housing or double-wall construction may be used. Fan pressure requirements shall be determined using the filter change out pressure drop. In cases where building use or occupancy generate airborne particles, vapors or gases that exceed typical concentrations special filtration components shall be used for the supply and return air. Alternatively, dedicated exhaust systems may be used to control the contaminants.
2. Panel filters have a low pressure drop, low cost, good efficiency on lint and larger particles (5 μm and larger), but low efficiency on normal atmospheric dust. This type of filter is commonly used as a pre-filter for higher efficiency filters. UL 900 Class 1 and Class 2 pleated panel features may be used. The filter media shall be cotton and synthetic fibers coated with nonflammable adhesive with a VOC content of 80 g/L or less. Media shall be bonded to frame to prevent air bypass and coated with an antimicrobial agent. Separators shall be bonded to the media to maintain pleat configuration. Welded wire grid shall be on downstream side to maintain pleat. Members on upstream and downstream sides shall be supported to maintain pleat spacing.
3. UL 900 Class 1 and 2 v-bank cell filters may also be used. V-bank cell filters consist of fibrous material constructed so individual pleats are maintained in tapered form under

rated-airflow conditions by flexible internal supports. Filter media frames shall be galvanized steel and mounting frames shall be welded galvanized steel with gaskets and fasteners.

Product Standards:

1. Filter Preferred Manufacturers:
 - a. AAF International.
 - b. Airguard.
 - c. Camfil Farr.
 - d. Columbus Industries, Inc.
 - e. CRS Industries, Inc.; CosaTron Division.
 - f. D-Mark.
 - g. Filtration Group.
 - h. Flanders-Precisionaire.
 - i. Koch Filter Corporation.
 - j. Purafil, Inc.
 - k. Research Products Corp.
 - l. Tri-Dim Filter Corporation.

Performance Standards:

1. Pre-filters shall have a MERV of 8, while final filters shall have a MERV of 13 as per ASHRAE Standard 52.2- 2007.
2. Maximum or rated face velocity for pleated panel filters shall be 300 fpm. The filter efficiency shall be 90 percent on particles 20 micrometers and larger at 500 fpm.
3. Maximum or rated face velocity for v-bank cell filters shall be 500 fpm.

23 41 33 High-Efficiency Particulate Filtration**Design Standards:**

1. High-efficiency particulate air (HEPA) filters and ultra low-penetration air (ULPA) filters are used for cleanroom and toxic-particulate applications.
2. The following high-efficiency particulate filtration components may be used:
 - a. HEPA rigid-cell box filters
 - b. HEPA V-bank cell filters
 - c. HEPA filter diffusers
 - d. HEPA filter fan modules
 - e. ULPA filters
 - f. 95 percent DOP filters

Product Standards:

1. Preferred Manufacturers:
 - a. AAF International
 - b. Airguard
 - c. Camfil Farr Co
 - d. Flanders-Precisionaire

Performance Standards:

1. HEPA and ULPA filters operate at duct velocities near 250 fpm, with resistance rising from 0.5 to more than 2.0 in. of water over the filter service life.

235700 Heat Exchangers for HVAC**Design Standards:**

1. Shell-and-tube or plate heat exchangers shall be used.
2. Shell-and-tube heat exchangers shall comply with "TEMA (Tubular Exchanger Manufacturers Association) Standards". Heat exchanger length, surface area, shell diameter, number of passes and quantity of heat exchanged shall be specified. For water-to water heat exchangers water flow rate, pressure drop, inlet/outlet temperatures, fouling factor and inlet/outlet sizes shall be specified.
3. Plate heat exchangers shall consist of frames with sufficient capacity to accommodate 20 percent additional plates. Plate heat exchangers selected shall have a 0.024 inch thick plate of Type 304 stainless steel. Heat exchanger surface area, number of plates, number of passes and quantity of heat exchanged shall be specified. For water-to water heat exchangers water flow rate, pressure drop, inlet/outlet temperatures, fouling factor and inlet/outlet sizes shall be specified.
4. Heat exchanger piping connections shall be fabricated of materials compatible with heat exchanger shell. Heat exchanger piping connections shall be consistent with the following according to pipe size:
 - a. NPS 2 and Smaller: Threaded ends according to ASME B1.20.1.
 - b. NPS 2-1/2 (DN 65) and Larger: Flanged ends according to ASME B16.5 for steel and stainless-steel flanges and according to ASME B16.24 for copper and copper-alloy flanges.

Product Standards:

1. Preferred Manufacturers:
 - a. Armstrong
 - b. TACO Incorporated
 - c. Bell&Gossett
 - d. Alpha-Laval

23 64 16 Centrifugal Compressor Water Chillers**Design Standards:**

1. Chiller full load COP and IPLV/NPLV shall be included on drawings. Chiller efficiencies shall meet or exceed the minimum requirements of ASHRAE 90.1. Chillers shall be rated in accordance with the latest edition of ARI Standard 550/590 and shall conform to the latest edition of ASHRAE 15 Safety Code. IPLU / NPLU ratings and condenser water relief shall be based on typical design temperatures encountered in South Florida.
2. Refrigerant shall be R-134a.
3. Compressors: Hermetic drive centrifugal compressor type is preferred over open drive compressor type.
4. Evaporator and Condenser:
Chiller capacity selection shall be based on a water side fouling factor of 0.00010 in the evaporator tubes and 0.00025 in the condenser tubes. Evaporator and condenser water pressure drops shall not exceed those scheduled on the Drawings.
Evaporator and condenser connections shall be flange pipe connections.
5. Controls:
Provide stand-alone direct digital controller for each chiller. Controller shall be microprocessor-based and BACnet compatible with factory packaging and testing of required control components for reliable equipment operation.
The chiller control panel shall provide control of chiller operation and monitoring of chiller sensors, actuator, relays and switches. The panel shall be a complete system for stand-alone chiller control and include controls to safely and efficiently operate the chiller. The panel shall be equipped with building automation system (BAS) interface.
6. Safeties: The chiller control panel shall monitor such safeties as motor starting and running, time between compressor motor starts, low chilled water temperature, high condenser, refrigerant pressure, low evaporator refrigerant temperature, evaporator and condenser water flows, low oil pressure, high oil temperature, and proper operation of unit controls and sensors.
7. Variable Frequency Drive: Provide where scheduled on Drawings. Justify the use of variable frequency drives by means of a Life-Cycle Cost Analysis.
8. Refrigerant Monitor: Provide calibrated, refrigerant monitor for specific refrigerant used, capable of detecting concentrations of 10 ppm for low level detection. Comply with applicable requirements of edition in effect of ASHRAE 15.
9. Chiller Purge System: Not required for chillers using R-134a refrigerant.
10. Pump-out System:

- a. Units operating with refrigerant having positive pressure at 75 degrees F (HFC-134a, etc.) shall have the capability of storing the entire refrigerant charge in the condenser or shall be provided with a pump-out system for each machine.
- b. Pump-out systems shall be complete with transfer pump, condensing unit, and tank constructed in accordance with ASME Code for Unfired Pressure Vessels bearing the National Board stamp.
- c. Pump-out systems shall be supplied and warranted by the chiller manufacturer.

Product Standards:

1. Preferred Manufacturers:
 - a. Trane
 - b. York
 - c. Carrier
 - d. McQuay
2. Chillers using Hydrochlorofluorocarbon (HCFC) type refrigerants are not acceptable.
3. Specify that a factory performance test for each chiller under full load and part load conditions in an ARI certified test facility. The manufacturer shall supply a certified test report to confirm performance as specified.
4. Notify the Owner fourteen (14) calendar days in advance to witness the performance test. Include in the bid price, all travel expenses for two (2) Owner's representatives to travel to testing facility to witness the performance test.
5. A certified test report of all data shall be submitted to the Engineer prior to Substantial Completion. An officer of the manufacturer's company shall sign the factory certified test report. Preprinted certification will not be acceptable; certification shall be in the original.

Performance Standards:

1. The selected chiller shall comply with the project sound levels requirements while running at full capacity.
2. The chiller shall perform at partial load according to ARI 550/590.
3. Efficiencies shall be as follow, comply with ASHRAE 90.1

23 64 23 Scroll Compressor Water Chillers**Design Standards:**

1. Comply with ARI 590 Certification program for scroll chillers.
2. Chiller controls shall be base on BACNET protocol of communication.

3. Refrigerant shall be R-134a or R-410a.
4. Controls: Provide stand-alone direct digital controller for each chiller. Controller shall be microprocessor-based and BACnet compatible with factory packaging and testing of required control components for reliable equipment operation.
5. The chiller control panel shall provide control of chiller operation and monitoring of chiller sensors, actuator, relays and switches. The panel shall be a complete system for stand-alone chiller control and include controls to safely and efficiently operate the chiller. The panel shall be equipped with building automation system (BAS) interface.
6. Safeties: The chiller control panel shall monitor such safeties as motor starting and running, time between compressor motor starts, low chilled water temperature, high condenser, refrigerant pressure, low evaporator refrigerant temperature, evaporator and condenser water flows, low oil pressure, high oil temperature, and proper operation of unit controls and sensors.

Product Standards:

1. Preferred Manufacturers:
 - a. Trane
 - b. York
 - c. Carrier
 - d. McQuay
 - e. AAON
2. Chillers using Hydrochlorofluorocarbon (HCFC) type refrigerants are not acceptable.
3. Specify that a factory performance test for each chiller under full load and part load conditions in an ARI certified test facility. The manufacturer shall supply a certified test report to confirm performance as specified.
4. Notify the Owner fourteen (14) calendar days in advance to witness the performance test. Include in the bid price, all travel expenses for two (2) Owner's representatives to travel to testing facility to witness the performance test.
5. A certified test report of all data shall be submitted to the Engineer prior to Substantial Completion. An officer of the manufacturer's company shall sign the factory certified test report. Preprinted certification will not be acceptable; certification shall be in the original.

Performance Standards:

1. The selected chiller shall comply with the project sound levels requirements while running at full capacity.
2. The chiller shall perform at partial load according to ARI 550/590.

3. Efficiencies shall be as follow, comply with ASHRAE 90.1

23 64 26 Rotary-Screw Compressor Water Chillers

Design Standards:

1. Comply with ARI 590 Certification program for rotary-screw water chillers.
2. Chiller controls shall be base on BACNET protocol of communication.
3. Refrigerant shall be R-134a or R-410a.
4. Controls: Provide stand-alone direct digital controller for each chiller. Controller shall be microprocessor-based and BACnet compatible with factory packaging and testing of required control components for reliable equipment operation.
5. The chiller control panel shall provide control of chiller operation and monitoring of chiller sensors, actuator, relays and switches. The panel shall be a complete system for stand-alone chiller control and include controls to safely and efficiently operate the chiller. The panel shall be equipped with building automation system (BAS) interface.
6. Safeties: The chiller control panel shall monitor such safeties as motor starting and running, time between compressor motor starts, low chilled water temperature, high condenser, refrigerant pressure, low evaporator refrigerant temperature, evaporator and condenser water flows, low oil pressure, high oil temperature, and proper operation of unit controls and sensors.

Product Standards:

1. Preferred Manufacturers:
 - a. Trane
 - b. York
 - c. Carrier
 - d. McQuay
2. Chillers using Hydrochlorofluorocarbon (HCFC) type refrigerants are not acceptable.
3. Specify that a factory performance test for each chiller under full load and part load conditions in an ARI certified test facility. The manufacturer shall supply a certified test report to confirm performance as specified.
4. Notify the Owner fourteen (14) calendar days in advance to witness the performance test. Include in the bid price, all travel expenses for two (2) Owner's representatives to travel to testing facility to witness the performance test.
5. A certified test report of all data shall be submitted to the Engineer prior to Substantial Completion. An officer of the manufacturer's company shall sign the factory certified test report. Preprinted certification will not be acceptable; certification shall be in the original.

Performance Standards:

1. The selected chiller shall comply with the project sound levels requirements while running at full capacity.
2. The chiller shall perform at partial load according to ARI 550/590.
3. Efficiencies shall be as follow, comply with ASHRAE 90.1

23 64 27 Magnetic Bearing Chillers**Design Standards:**

1. Chiller full load COP and IPLV/NPLV shall be included on drawings. Chiller efficiencies shall meet or exceed the minimum requirements of ASHRAE 90.1. Chillers shall be rated in accordance with the latest edition of ARI Standard 550/590 and shall conform to the latest edition of ASHRAE 15 Safety Code. IPLV / NPLV ratings and condenser water relief shall be based on typical design temperatures encountered in South Florida.
2. Refrigerant shall be R-123 or R-134a.
3. Compressors: Semi-hermetic oil free magnetic bearing compressor.
 - a. The compressor is to be oil-free.
 - b. The compressor shall have an integrated VFD component.
 - c. Single or multiple Compressor for redundancy.
4. Evaporator and Condenser:

Chiller capacity selection shall be based on a water side fouling factor of 0.00010 in the evaporator tubes and 0.00025 in the condenser tubes. Evaporator and condenser water pressure drops shall not exceed those scheduled on the Drawings. Evaporator and condenser connections shall be flange pipe connections.
5. Controls:
 - a. Provide stand-alone direct digital controller for each chiller. Controller shall be microprocessor-based and BACnet compatible with factory packaging and testing of required control components for reliable equipment operation.
 - b. The chiller control panel shall provide control of chiller operation and monitoring of chiller sensors, actuator, relays and switches. The panel shall be a complete system for stand-alone chiller control and include controls to safely and efficiently operate the chiller. The Panel shall be equipped with building automation system (BAS) interface. Data on Main Display Screen shall include:
 - 1) Entering and leaving chilled water temperatures.
 - 2) Entering and leaving condenser water temperatures.
 - 3) Current operating state of chiller.
 - 4) Active timer.

- 5) Chiller Enable Status.
 - 6) Chiller water flow proof status.
 - 7) Condenser water flow proof status.
 - 8) Indication of compressor readiness.
 - 9) Indication of clearance to run.
 - 10) Chiller set point.
 - 11) Total chiller kW.
 - 12) Total chiller current input.
 - 13) Three pages of data trends with Zoom functionality.
 - 14) Graphical dial indicators that clearly indicate safe and unsafe operating values.
 - 15) Graphical representation of evaporator and condenser showing gas movement when chiller is running.
 - 16) Current Alarms (announce and manual reset provision).
 - 17) Compressor actual rpm, maximum, rpm, minimum rpm.
 - 18) Compressor alarm description & fault description.
 - 19) Compressor percentage motor demand.
 - 20) Compressor safety interlocks status.
 - 21) Compressor Modbus communication health status.
 - 22) Compressor suction and discharge pressures.
 - 23) Compressor suction and discharge temperatures.
 - 24) Compressor internal cooling system temperatures and status.
 - 25) Compressor motor kW and amps.
 - 26) Compressor pressure ratio.
6. Safeties: The chiller control panel shall monitor such safeties as motor starting and running, time between compressor motor starts, low chilled water temperature, high condenser, refrigerant pressure, low evaporator refrigerant temperature, evaporator and condenser water flows, and proper operation of unit controls and sensors.
7. Variable Frequency Drive: Provide unit mounted compressor variable speed drive.
8. Refrigerant Monitor: Provide calibrated, refrigerant monitor for specific refrigerant used, capable of detecting concentrations of 10 ppm for low level detection. Comply with applicable requirements of edition in effect of ASHRAE 15.
9. Pump-out System:
- a. Units operating with refrigerant having positive pressure at 75 degrees F (HFC-134a, etc.) shall have the capability of storing the entire refrigerant charge in the condenser or shall be provided with a pump-out system for each machine.
 - b. Pump-out systems shall be complete with transfer pump, condensing unit, and tank constructed in accordance with ASME Code for Unfired Pressure Vessels bearing the National Board stamp.
 - c. Pump-out systems shall be supplied and warranted by the chiller manufacturer.

Product Standards:

1. Preferred Manufacturers:
 - a. Trane
 - b. York
 - c. Carrier
 - d. McQuay
 - e. Smardt
2. Chillers using Hydrochlorofluorocarbon (HCFC) type refrigerants are not acceptable.
3. Specify that a factory performance test for each chiller under full load and part load conditions in an ARI certified test facility. The manufacturer shall supply a certified test report to confirm performance as specified.
4. Notify the Owner fourteen (14) calendar days in advance to witness the performance test. Include in the bid price, all travel expenses for two (2) Owner's representatives to travel to testing facility to witness the performance test.
5. A certified test report of all data shall be submitted to the Engineer prior to Substantial Completion. An officer of the manufacturer's company shall sign the factory certified test report. Preprinted certification will not be acceptable; certification shall be in the original.
6. Insulate all cold surfaces with a minimum of 2" thick closed cell insulation.
7. Provide vibration isolation mounts.

Performance Standards:

1. The selected chiller shall comply with the project sound levels requirements while running at full capacity.
2. The chiller shall perform at partial load according to ARI 550/590.
3. Efficiencies shall be as follow, comply with ASHRAE 90.1
4. Sound Pressure rating shall be 76 dBA –AHRI Standard 575.
5. Integrated Part Load Value (IPLV) shall be as specified on Plans.
6. Performance shall be certified in accordance with AHRI Standard 550/590.

23 64 28 Chiller Plant Requirements**Design Standards:**

1. Chilled water Supply Temperature of 42 deg. F and delta T of 12 to 16.
2. Condenser water supply characteristics as per CTI (Cooling Tower Institute) 95 deg. F condenser water return, 85 deg. F water supply with a delta T of 10 degrees, 78 deg. F wet bulb .
3. The minimum temperature differential for coils is 12 deg. F.
4. Chiller Plant Refrigerant Monitoring:
 - a. Compliant with ASHRAE Standard 15-1 2013.
 - b. Provide Alarm System.
 - c. Provide Plant Ventilation according to the Refrigerant used in the Chiller Plant.
 - d. Provide oxygen respirators in locations compliant with Standard 15-1.
 - e. Locate sensors near Chillers as recommended by Manufacturer.
5. Chiller Plant Refrigerant Purge:
 - a. Compliant with ASHRAE Standard 15-1 2013.
 - b. Provide Plant Ventilation according to the Refrigerant used in the Chiller Plant.
 - c. Provide oxygen respirators in locations compliant with Standard 15-1.
 - d. The Refrigerant shall be vented to the outside either thru the wall or an alternate location thru the roof.
 - e. The venting pipe shall have a rupture disc assembly, a flexible steel connection, a Purge vent line and a drip leg terminating in a ¼"FLx1/4" NPT drain valve
6. Consider variable flow Chillers.
7. Consider variable flow Cooling Towers.
8. Consider variable flow pumping system.

Chiller Plant Load Efficiency Requirements**Design Standards:**

1. Compliance with ASHRAE Standard 90.1.
2. Compliance with AHRI 550/590
3. Provide equipment with lowest Kw/Ton and Life Cycle Cost available. Perform Life Cycle Cost Analysis.

Performance Standards:

1. Testing of the Chiller Plant for compliance with lowest Kw/Ton calculated in Life Cycle Cost Analysis.
2. Testing of the Chillers and Cooling Towers for water flow compliance.

3. Testing of the Pumping System for flow and head compliances.
 4. Testing and Balancing of the ventilation systems required by Standard 15.
 5. Testing of the Chiller Plant for compliance with Standard 15
 6. Make corrections to the Chiller Plant Refrigerant Monitoring Systems as required.
7. LEED Specific Criteria for HVAC Systems

As a minimum consider the following when designing to meet LEED requirements:

- a. Magnetic Bearing Chillers LEED Product points in EAc 1 and EAc 4.
- b. Type of Refrigerant, LEED Credit.
- c. Cooling Tower Chemical Management. Improving water efficiency with:
 - 1) A conductivity meter and automatic controls adjust bleed rate and maintain proper concentration at all times.
 - 2) Use make-up water at least 50% non-potable.
 - 3) Create Program to verify make-up water quantities.
 - 4) Meter make-up water.
 - 5) Recycled condensate drainage.
 - 6) Recycled Water.
 - 7) Cooling towers for air conditioning systems, such as chilled water systems, shall achieve a minimum of five cycles of concentration based on a ratio of the conductivity of the water being discharged (blowdown) divided by the conductivity of the feed (makeup) water(s), or four cycles of concentration, if the makeup water hardness exceeds 200 mg/l expressed as calcium carbonate, or shall achieve a minimum discharge (blowdown) concentration of 1500 mg/L (1500 ppm) expressed as calcium carbonate, or 175 mg/L (175 ppm) of silica measured as silicon dioxide, whichever is met first.
 - 8) Cooling towers shall be equipped with makeup and blowdown meters, conductivity controllers and overflow alarms and efficient drift eliminators that reduce drift loss to less than, or equal to, 0.001% of recirculating water in a counter-flow tower or 0.005% in a cross-flow tower.
 - 9) Use no more potable water than 2.3 gallons per ton hour (2.5 liters per kilowatt hour) for cooling tower make-up.

23 65 00 Cooling Towers

Design Standards:

1. All cooling towers shall be factory fabricated, vertical discharge, induced draft counterflow type. The manufacturers shall comply with CTI testing requirements and make sure that their equipments are rated for minimum hurricane loads of 125 psf.

2. The cooling tower(s) shall be installed on steel structural support in accordance with manufacturer's installation recommendations
3. No modular cooling towers are acceptable.

Product Standards:

1. Acceptable manufactures are:
 - a. Marley
 - b. BAC
 - c. Evapco
 - d. American Cooling Towers
2. Construction shall be stainless steel.
3. Basin Sections:
 - a. Provide cold water basin with side outlet connections consisting of suction, overflows, and drain piping.
 - b. Condenser water outlet connections with a clog resistant, lift out strainer with perforated openings sized smaller than spray nozzle orifices, mounted in assemble with an anti-cavitation device.
4. Fan Sections:
 - a. Provide ultra low noise fans.
 - b. Provide single fan propeller type with corrosion resistant cast aluminum blades, adjustable pitch, individually attached to a cast aluminum or cast iron hub.
 - c. Provide heavy gauge hot dipped galvanized wire grill type fan guard over fan cylinder.
 - d. Provide fan with vibration switch to de-energize fan in the event of excessive vibration. The vibration switch shall be tied to the Building Management System (BMS).
5. Fan Bearings
 - a. Heavy duty roller type bearings integral with gear reducer.
6. Fan Drives
 - a. Fan shall be driven through helical gear reducer. Gear reducer shall have synthetic rubber oil seals and shall be designed to require oil changes on five year intervals. Speed reducers employing pulleys and belts shall not be acceptable unless manufacturer warrants such speed reducing equipment to be maintenance free for a five (5) year period.
7. Fan Motor
 - a. Motor(s) shall be TEFC, 1.15 service factor, variable torque, and specially insulated for cooling tower duty. Motor shall operate in the shaft-horizontal position and nameplate horsepower shall not be exceeded at design operation.

- b. All cooling towers shall have variable speed driven fans.
8. Tower fill and drift eliminators
- a. Tower fill shall be lightweight and manufactured of non-corrosive material.
 - b. Drift eliminators shall be two-pass manufactured of non-corrosive honeycomb type material supported in galvanized steel framing. Maximum allowable drift loss shall be less than 0.2 percent of the water circulated.
9. Basin filtration
- a. Provide basin filtration system consisting of filters, pump and all necessary controls.

Performance Standards:

1. The cooling towers shall be designed for incoming water at 95°F degrees. Leaving water temperature shall be at least 10°F degrees lower.
2. Bearings shall be provided for a minimum of 75,000 hours of operation.
3. The drift rate shall not exceed 0.005% of the circulating water rate.
4. The cooling tower shall be provided with a five years total tower warranty.

23 72 00 Air-To-Air Energy Recovery Equipment**Design Standards:**

1. Design documents shall include summer and winter performance of energy recovery equipment including entering and leaving dry bulb and wet bulb temperatures, and energy recovery effectiveness.
2. Coordinate with other disciplines to ensure provisions for maintenance including a nearby hose bibb.
3. Insulation shall comply with NFPA 90A requirements for flame spread and smoke generation.
4. Unit cabinet and exterior components shall be tested and certified weatherproof.
5. Provide filters for every air intake. Filters shall be disposable.
6. All electrical components, devices, and accessories listed and labeled as defined in NFPA 70 Article 100 by a testing agency shall be acceptable to authorities having jurisdiction and shall be marked for intended use.

Product Standards:

1. Manufacturer[s]: Subject to compliance with requirements, provide units by one of the following:
 - a. AnnexAir
 - b. Des Champs
 - c. Semco
 - d. Venmar Ventilation

Performance Standards:

1. Manufacturer shall provide an 18-month warranty on all parts and labor, and a 5-year on the enthalpy wheel excluding labor.

23 73 13 Modular Indoor Central-Station Air-Handling Units**Design Standards:**

1. The minimum wall thickness for modular units shall be 2". The minimum wall thickness for custom units with fiberglass insulation shall be 4", except 2" foam insulated panels are permitted if such panels match the performance of 4" thick fiberglass insulated panels.
2. For units above 10,000 CFM, each access section shall be illuminated.
3. Drain pans shall be designated as above floor type. Avoid floor recessed drain pans due to the difficulty of replacement. Drain pans shall be stainless steel. Plastic drain pans are acceptable in units of less than 2000 CFM. Drain pans shall be sloped.
4. Access sections shall be provided to allow up and down stream access to every unit component. For example, an access module shall be provided between each heating coil and cooling coil section; both the air entering and air leaving side of each coil shall be visible for inspection. The designer must accommodate these access sections when fitting units into the available space.
5. For large custom and modular units (> 20,000 CFM), in particular those with a large outside air component, consider (with the U-M Design Coordinator) providing an access section between the pre and final filters of adequate size to allow the final filters to be replaced from the upstream side without removing the pre-filters. As an alternative to the above, a hinged pre-filter section may be specified. For hinged pre-filter configurations, also specify a gap between the pre-filter and final filter frames to allow a static pressure tap to be installed so that a separate pressure drop reading may be taken across the pre and final filter banks.

6. Hinged access doors are required in each access section.
7. Maximum face velocities shall be based on any future capacity allowance for the AHU.
8. For units 10,000 CFM or greater, coil tracks and individual coil access panels shall be specified.
9. Coils shall have a maximum fin spacing of 10 FPI. When this criterion cannot be met, provide two coils piped in a series arrangement.
10. When multiple coils are stacked vertically, each coil in the stack shall be equipped with a balancing valve.
11. Units shall be provided with ultra violet section with access panels.
12. Units shall include pre-filters and final filters, except in very small, non-critical units. Filters shall be disposable.
13. Limit fans speeds to 1200-1400 RPM.
14. Forward curved fans shall not be specified accept when air foil or backward inclined or plenum fans are available. When plenum fans are utilized, specify a “guard cage” around the fan for safety. The impacts on fan performance of such cages as well as impacts from any inlet mounted back draft dampers shall be evaluated when selecting such fans. Specify multiple direct drive, VFD controlled, plenum fans whenever possible.
15. All coils must be treated with a factory applied corrosion inhibitor coating.
16. The evaporator coil shall be provided with a stainless steel drain pan.

Product Standards:

1. Preferred Manufacturers:
 - a. Trane
 - b. York
 - c. Carrier
 - d. McQuay

Performance Standards:

1. Units casing shall be leak free, as well as the units coil.
2. The unit shall deliver the specified airflow (+/-10%) once installed.
3. Submittal data shall include certified sound power data for all air handling units for review and approval. Submit ratings in the eight-octave bands for radiated casing, discharge supply opening and discharge return opening sound power levels. AHU's shall not exceed the following sound power levels.

23 74 13 Packaged, Outdoor, Central-Station Air-Handling Units**Design Standards:**

1. Consult the Architect and the UM Design Manager to determine if a custom paint color or screening is required.
2. Design documents shall require unit a factory roof curb to be included. Whenever units are to be installed above sound and/or vibration sensitive areas, specify insulated roof curbs with vibration isolation base rails.
3. The minimum wall thickness for modular units shall be 2". The minimum wall thickness for custom units with fiberglass insulation shall be 4". 2" foam insulated panels are permitted if such panels match the performance of 4" thick fiberglass insulated panels.
4. Units shall meet Florida Building Code requirements for outdoor equipment wind ratings.
5. For units above 10,000 CFM, each access section shall be illuminated.
6. Drain pans shall be designated as above floor type. Avoid floor recessed drain pans due to the difficulty of replacement. Drain pans shall be stainless steel. Plastic drain pans are acceptable in units of less than 2000 CFM. Drain pans shall be sloped.
7. Access sections shall be provided to allow up and down stream access to every unit component. For example, an access module shall be provided between each heating coil and cooling coil section; both the air entering and air leaving side of each coil shall be visible for inspection. The designer must accommodate these access sections when fitting units into the available space.
8. For large custom and modular units (> 20,000 CFM), in particular those with a large outside air component, consider (with the U-M Design Coordinator) providing an access section between the pre and final filters of adequate size to allow the final filters to be replaced from the upstream side without removing the pre-filters. As an alternative to the above, a hinged pre-filter section may be specified. For hinged pre-filter configurations, also specify a gap between the pre-filter and final filter frames to allow a static pressure tap to be installed so that a separate pressure drop reading may be taken across the pre and final filter banks.
9. Hinged access doors are required in each access section.
10. Maximum face velocities shall be based on any future capacity allowance for the AHU.
11. For units 10,000 CFM or greater, coil tracks and individual coil access panels shall be specified.

12. Coils shall have a maximum fin spacing of 10 FPI. When these criteria cannot be met, provide two coils piped in a series arrangement.
13. When multiple coils are stacked vertically, each coil in the stack shall be equipped with a balancing valve.
14. Units shall be provided with ultra violet section with access panels.
15. Units shall include pre-filters and final filters, except in very small, non-critical units. Filters shall be disposable.
16. Limit fans speeds to 1200-1400 RPM.
17. Forward curved fans shall not be specified when air foil or backward inclined or plenum fans are available. When plenum fans are utilized, specify a “guard cage” around the fan for safety. The impacts on fan performance of such cages as well as impacts from any inlet mounted back draft dampers shall be evaluated when selecting such fans. Specify multiple direct drive, UFD controlled, plenum fans whenever possible.
18. All coils must be treated with a factory applied corrosion inhibitor coating.
19. The evaporator coil shall be provided with a stainless steel drain pan.

Product Standards:

1. Preferred Manufacturers:
 - a. Trane
 - b. York
 - c. Carrier
 - d. McQuay

Performance Standards:

1. Units casing shall be leak free, as well as the units coil.
2. The unit shall deliver the specified airflow (+/-10%) once installed.
3. Submittal data shall include certified sound power data for all air handling units, for review and approval. Submit ratings in the eight-octave bands for radiated casing, discharge supply opening and discharge return opening sound power levels.

23 74 33 Packaged, Outdoor or Rooftop Air Conditioning Units

Design Standards:

1. Packaged unit controls shall be base on BACNET protocol of communication.

2. Refrigerant shall be R-410a or equal. The units, completely factory assembled and tested, piped, internally wired, shall be fully charged with refrigerant R-410A (or equal), compressor oil and shipped in one piece.
3. Design documents shall require unit a factory roof curb to be included. Whenever units are to be installed above sound and/or vibration sensitive areas, specify insulated roof curbs with vibration isolation base rails.
4. Exterior surfaces of unit shall be phosphatized, zinc-coated steel (1.25 oz. per square foot minimum), with baked enamel finish. Screws shall be coated with zinc-plus-zinc chromate and with neoprene washers where sealing is required.
5. Hinged access doors shall provide access to control components, filters, outside/return air dampers, evaporator coil, and supply and exhaust fan sections. Access doors and removable panels shall be double wall construction with 2 lb density insulation sandwiched between galvanized steel panels and complete with neoprene gaskets.
6. Drain shall be provided on each side of the evaporator section. Drain pans shall be stainless steel, sloped.
7. Units serving variable air volume air distribution systems shall be suitable for their intended use and shall be equipped with variable frequency drives to modulate supply fan speeds. Units serving variable air volume systems shall be equipped with compressors that are capable of modulating between 10% and 100% of cooling capacity. Units shall be provided with hot gas bypass.
8. Obtain approval from UM authorities whenever a packaged variable air volume system that uses a change-over bypass is intended.
9. Where applicable for building air relief, require a factory installed exhaust fan and required dampers.
10. Filters shall be disposable.
11. All coils must be treated with a factory applied corrosion inhibitor coating.
12. The evaporator coil shall be provided with a stainless steel drain pan.

Product Standards:

1. Preferred manufacturers:
 - a. Trane
 - b. AAON
 - c. Carrier
 - d. Yoork
 - e. McQuay

Performance Standards:

1. Warranty Period for Compressors: Five years from date of Substantial Completion.
2. Warranty Period for Heat Exchangers: Ten years from date of Substantial Completion.

23 81 13 Packaged Terminal Air-Conditioners**Design Standards:**

1. The following packaged terminal air conditioner configurations may be used if suitable for their intended use:
 - a. Through-the-wall and freestanding air conditioners.
 - b. Cooling-only units.
 - c. Heat-pump units.
 - d. Cooling units with electric heat.
 - e. Cooling units with hydronic heat.
 - f. Cooling units with indirect-fired gas heat.
2. Packaged terminal air-conditioners are typically used to provide total cooling functions for a room or zone and are specifically for through-the-wall installation.
3. Packaged terminal air-conditioners shall be factory-assembled and tested, self-contained units with room cabinet, electric refrigeration system and temperature controls. Unit shall be fully charged with refrigerant R-410A and filled with oil. Unit shall have a cord-connected or hardwired chassis.
4. Unit refrigeration system shall consist of a direct-expansion indoor coil with capillary restrictor and hermetically sealed scroll compressor with vibration isolation and overload protection. Indoor and outdoor coils shall consist of seamless copper tubes mechanically expanded into aluminum fins with capillary tube distributor on indoor coil.
5. Drain pan construction and connections shall comply with ASHRAE 62.1.
6. Filters shall be disposable.
7. The outdoor coil must be treated with a factory applied corrosion inhibitor coating.

Product Standards:

1. Preferred Manufacturers:
 - a. Carrier
 - b. ClimateMaster
 - c. General Electric
 - d. McQuay International
 - e. Trane

Performance Standards:

1. Packaged terminal air-conditioners shall comply with applicable requirements in ASHRAE 62.1, and ASHRAE 90.1.

23 81 23 Computer-Room Air-Conditioners**Design Standards:**

1. The units (CRAC Units) dedicated to serve computer rooms shall be independent from other systems. Cross connections with other systems shall be provided for back-up purposes, and must be tied to the Building Management System (BMS).
2. Redundancy on computer room air conditioning systems shall be provided to compensate for failures and maintenance without reducing the required cooling capacity.
3. Where Chilled water is available provide dual coil CRAC Units (Chilled water and DX)
4. Designer shall require CRAC units with humidifiers whenever the anticipated relative humidity (based on psychrometric analysis) is below 30%.
5. Whenever the heat dissipation density from computer equipment is unreasonably high, consider using in-rack cooling systems as opposed to air distribution systems to address the equipment loads. However, even when in-rack cooling systems are present, CRAC units are required to address loads from the building envelope, lighting, occupants, UPS and other computer equipment not contained in racks.
6. Obtain approval from the UMBS Committee for the main cooling source of any in-rack cooling system.
7. CRAC units, as well as any powered component of an in-rack cooling system shall be included in the emergency generator power.
8. Filters shall be disposable.

Product Standards:

1. Preferred manufacturers:
 - a. Liebert Corporation
 - b. APC
2. Computer Room Air Conditioning Units shall be built and tested in accordance with ANSI/ASHRAE Standard 127.

Performance Standards:

1. CRAC Units shall be capable to overcome the computer room load on a year round 24/7 schedule and maintain a maximum temperature of 70°F and relative humidity between 30% and 50%.
2. Units shall comply with applicable requirements in ASHRAE 62.1, and ASHRAE 90.1.

23 81 26 Split-System Air-Conditioners**Design Standards:**

1. Split-system air conditioners shall provide sufficient capacity to cool the proposed space or building. Split-system air-conditioning units consist of separate evaporator-fan and compressor-condenser components. Units shall utilize refrigerant R-410.
2. Outdoor coils must be treated with a factory applied corrosion inhibitor coating.
3. The evaporator coil shall be provided with a stainless steel drain pan.

Product Standards:

1. Preferred Manufacturers:
 - a. Carrier
 - b. Trane
 - c. McQuay
 - d. YORK

Performance Standards:

1. Units shall comply with applicable requirements in ASHRAE 62.1 and ASHRAE 90.1.

23 82 16 Air Coils**Design Standards:**

1. Water, and refrigerant coils selected shall be tested and rated according to ARI 410 and ASHRAE 33.
2. All coils must be treated with a factory applied corrosion inhibitor coating.

Product Standards:

1. Preferred Manufacturers:
 - a. Aerofin Corporation
 - b. Carrier
 - c. McQuay
 - d. Trane.
 - e. USA Coil & Air

Performance Standards:

1. Coils shall be suitable for their intended use and shall provide the performance specified in design documents without unwanted variations.

23 82 19 Fan Coil Units

Design Standards:

1. Fan coil units shall be factory-packaged and tested according to ARI 440, ASHRAE 33, and UL 1995.
2. Coordinate finishes of exposed units with architects and university authorities.
3. Provide fan coil unit with a stainless steel drain pan.

Product Standards:

1. Preferred Manufacturers:
 - a. Carrier
 - b. International Environmental Corporation
 - c. McQuay
 - d. Trane
 - e. York

Performance Standards:

1. Units shall comply with applicable requirements in ASHRAE 62.1 and ASHRAE 90.1.
2. Units shall be provided with three row cooling coils, minimum.

THIS DOCUMENT IS PROVIDED TO THE PROJECT DESIGN ENGINEER AS A BASIS OF DESIGN DOCUMENT. THE ENGINEER IS SOLELY RESPONSIBLE FOR THE FINAL DESIGN AND IMPLEMENTATION OF THIS SPECIFICATION. FURTHER SPECIFICATION DETAILS ARE EXPECTED TO BE PROVIDED BY THE ENGINEER OF RECORD. THE ENGINEER SHOULD MODIFY THIS DOCUMENT AS REQUIRED TO MEET SPECIFIC PROJECT REQUIREMENTS WHICH COULD INCLUDE, BUT NOT BE LIMITED TO, SPECIAL CONTROLLERS, ADDITIONAL SENSOR TYPES, AND ADDITIONAL INSTALLATION REQUIREMENTS. THE ENGINEER SHALL ALSO FOLLOW THE STANDARD CONTROL DIAGRAM TEMPLATES (APPENDIX A.1), STANDARD SEQUENCES (APPENDIX A.2) AND STANDARD POINT LIST (APPENDIX A.3) WHEN DESIGNING THE CONTROL SYSTEM. DEVIATIONS FROM THIS OR ANY OTHER ASSOCIATED UM CONSTRUCTION STANDARDS SHALL BE COMMUNICATED TO THE UM PROJECT MANAGER IN WRITTEN FORM USING A "REQUEST FOR REVISION / DEVIATION FROM UM STANDARDS" FORM AND IN SUFFICIENT TIME FOR REVIEW, DISCUSSION, AND APPROVAL BY UM FACILITIES PRIOR TO ISSUANCE OF THE FINAL CONSTRUCTION DOCUMENT PACKAGE.

1 GENERAL

- 1.1 Related Documents: Drawings and general provisions of the Contract, including General and Supplementary Conditions and other Division 01 Specification Sections apply to this Section.
- 1.2 Extent of Building Automation System Integration (EBMS) work required by this section is indicated on drawings and by requirements of this section. This contractor is also referred herein as the EBMS Contractor and shall coordinate all work with the Building Level Control (BLC) Contractor.
- 1.3 Provide the following electrical work as work of this section: wiring incidental to server and auxiliary devices.
- 1.4 Refer to other Division 23 09 00 Section for installation of Building Automation System components (BAS) executed by the BLC Contractor, not work of this Section.
- 1.5 Reference additional standard point list documents (Appendix A.3) for additional requirements and supplemental information.
- 1.6 General Description: Provide an EBMS that will serve as the unifying integrated supervisory management system for the project. The EBMS will function as the single point of interface to the BLC system and provide advance supervisory level algorithmic control over such sub-systems.
- 1.7 Provide the following support for Commissioning: as work of this Section, complying with the requirements of this Section. Contractor shall provide all services as required to assist the Commissioning Agent in all verification activities related to the EBMS and the integration of the BLC System.

IN GENERAL, THE UM STANDARD IS TO COMMISSION ALL PROJECTS. COORDINATE CX REQUIREMENTS WITH UM PROJECT MANAGER AND ENSURE APPROPRIATE SPEC SECTIONS ARE INCLUDED AND REFERENCED IN THIS SECTION.

1.8 Codes and Standards:

1.8.1 Electrical Standards: Provide electrical products which have been tested, listed and labeled by UL and comply with NEMA standards.

1.9 Supervisory Level Control:

1.9.1 The EBMS will function as the upper level supervisory controlling mechanism for all BLC functions. The EBMS will control such parameters as set points, operating mode control, scheduling, trending, alarm processing, and time dependent command initiation. The overall implementation of the EBMS will allow for improved efficiencies while maintaining building conditions through supervisory level control.

1.9.2 The EBMS system will issue supervisory level information to the BLC system via open communication protocols (BACnet/IP). The BLC system will, upon receipt of the supervisory level information, implement its internal logic to achieve the desired function. Any disruption of communication between the EBMS and the BLC system shall result in the continued operation of the local building controller at the last known supervisory command.

1.10 Ownership of Proprietary Material

1.10.1 Project specific software and documentation shall become the University of Miami property. This includes, but is not limited to:

1.10.1.1 Graphics

1.10.1.2 Record drawings

1.10.1.3 Database

1.10.1.4 Application specific software

1.10.1.5 Application programming code

1.11 Codes and Standards:

1.11.1 Electrical Standards: Provide electrical products which have been tested, listed and labeled by UL and comply with NEMA standards.

1.11.2 NEMA Compliance: Comply with NEMA standards pertaining to components and devices for electric control systems.

1.11.3 Federal Communication Commission (FCC): All digital equipment shall have been tested and made to comply with limits for Class A computing device pursuant to Subpart J of Part 15 of FCC Rules, which are designed to provide reasonable protection against interference when operated in commercial environment. All manufacturer's literature

shall so note, and all equipment shall be so labeled, to indicate this compliance.

1.11.4 BACnet: Comply with ASHRAE 135 Data Communication Protocol for Building Automation and Control Networks' where applicable to EBMS hardware and software.

1.12 Definitions and Abbreviations:

1.12.1 A/E - Architect/Engineer

1.12.2 AI - Analog Input

1.12.3 AO - Analog Output

1.12.4 Analog - A continuously variable system or value not having discrete levels. Typically exists within a defined range of limiting values (e.g. temperature).

1.12.5 Auto-Tune - Software routine used to adjust tuning parameters based on historical or real-time data

1.12.6 ASC - Application Specific Controller

1.12.7 BLC - Building Level Control system supervisory building level control system and the primary means of communication outside the building.

1.12.8 Control Sequence - A BLC system pre-programmed arrangement of software algorithms, logical computation, target values and limits as required to attain the defined operational control objectives.

1.12.9 DDC - Direct Digital Control

1.12.10 Binary - A two-state system where an 'ON' condition is represented by one discrete signal level and an 'OFF' condition is represented by a second discrete signal level each separated by a defined deadband. Binary Inputs and Binary Outputs are discrete (e.g. fan status).

1.12.11 DI - Discrete Input

1.12.12 DO - Discrete Output

1.12.13 Discrete A two state condition on/off, normal/alarm dirty/clean etc.

1.12.14 EBMS – Enterprise Building Management system

1.12.15 GUI - Graphical User Interface

1.12.16 IP - Internet Protocol

1.12.17 HOA - Hand Off Auto

1.12.18 LOT - Local Operator Terminal

1.12.19 Modulating - Movement of a control device through an entire range of values proportional to an infinitely variable input value.

1.12.20 Node - DDC panel, user workstation, or other control device connected to communications network.

1.12.21 OWS - Operator's Work Station (desktop PC with Intranet / Internet capability)

1.12.22 PDA - personal digital assistant or Smart Phone

1.12.23 Peer-to-Peer - Mode of communication between controllers in which each device connected to network has equal status and each shares its database values with all other devices connected to network.

1.12.24 Point - Analog or discrete instrument with addressable database value.

1.12.25 Protocol - The term 'protocol' and its derivatives when used in this Section shall mean a defined set of rules and standards governing the on-line exchange of data between control systems of the same or different manufacturers.

1.12.26 Router - Device for implementation of Network Layer Protocol (i.e. BACnet/IP)

- 1.12.27 Software - The term 'software' and its derivatives when used in this Section shall mean all programmed digital processor software, preprogrammed firmware and project specific digital process programming and database entries and definitions as generally understood in the control industry for real-time, on-line, integrated control system configurations.
- 1.12.28 Thin Client B A client computer or client software in client-server architecture networks which depends primarily on the central server for processing activities, and mainly focuses on conveying input and output between the user and the remote server.
- 1.12.29 Thick (Fat or Rich) Client B A client computer in client-server architecture networks which typically provides rich functionality independently of the central server. The thick client still requires at least periodic connection to a network or central server.
- 1.12.30 Tier 1 - LAN and/or WAN communication network. Building to building communication or high speed communication level running within a specific building (i.e. Ethernet).
- 1.12.31 Tier 2 - Building level communication or low speed tier running under a building level controller supervisory controller.
- 1.12.32 UM B University of Miami.
- 1.13 Submittals:
- 1.13.1 Product Data: Submit manufacturer's technical product data for each device and software packaged furnished, indicating dimensions, capacities, performance characteristics, electrical characteristics, version number, finishes of materials and any other characteristic required by this Section. Include installation instructions and start-up instructions. Provide technical specification data for each component and software module organized with major tabs to separate major sections and a master index indicating all elements of submittal. Product cut sheets shall indicate specific parts and software package proposed for project.
- 1.13.2 Shop Drawings: Submit shop drawings for the EBMS containing the following information:
- 1.13.2.1 Schematic flow diagram of system showing all equipment and devices to be integrated. Diagram shall include a detailed network diagram of all project controllers residing on the UM Ethernet and shall be coordinated with BLC contractor.
- 1.13.2.2 Points schedule for each real and virtual point to be integrated into the EBMS, including: tag, point type, point name, display units, and address. Coordinate with BLC Contractor.
- 1.13.2.3 Samples of all system graphics including floor plans, system diagrams and associated menu penetrations to show graphical hierarchy, proposed point data locations, and functional interrelationships. The project shall include the development of all building and updated campus site plan graphics.
- 1.13.2.4 Detailed bill of material list for each system and software component identifying quantity, part number, description, and optional features selected.

- 1.13.2.5 Provide an alarm response matrix indicating points to be alarmed, alarm limits or activation triggers. Provide a proposed master/slave event statement describing the enhanced alarming triggers and responses.
- 1.14 Test Reports and Verification Submittals:
- 1.14.1 Submit system verification letter from manufacturer's representative stating that all EBMS components have been installed, checked, calibrated, started up and verified for proper operation with the BLC contractor. State that the Owner training has been completed and provide a roster of attendees.
- 1.15 O&M Data Submittals:
- 1.15.1 Maintenance Data: Submit inspection requirements, periodic preventive maintenance recommendations, and fault diagnosis, instructions for repair or replacement of defective software. Include product data, and a copy of all approved submittals in O&M Manual.
- 1.15.1.1 In addition to the maintenance data requirements, provide a description of the information flow to and from panels and devices and describe the overall communications network.
- 1.15.2 Software Manual: Provide the following in a separate bound software manual with tabs separating each section. Provide the scanned software manual on CD or DVD media.
- 1.15.2.1 Complete description of operating system including all text definitions, commands, configuration programs, printouts, logs, database functions and passwords. Describe general operating procedures, starting with system overview and proceeding to detailed description of each software command feature with sample printed displays and system function description for each option. Include instructions on verifying errors, status, changing passwords and initiating or disabling control programs.
- 1.15.2.2 Complete description of programming language including all commands, configuration programs, and testing. Describe general programming procedures, starting with system overview and proceeding to detailed description of each software command feature. Include instructions on creating or modifying any control algorithm or parameter, debugging, etc. This shall include all control functions, algorithms, mathematic equations, variables, setpoints, time periods, messages, and other information necessary to load, alter, test and execute custom or pre-written programs. Factory standard technical manuals shall be provided in lieu of copied subsections. Existing manuals shall be updated or replaced to be current with latest software version.
- 1.15.3 Electronic Data: Submit a copy of all software. Install all product operational and maintenance data as-built control diagrams, and as-built sequences in electronic PDF format (Acrobat latest version- 6.0 or greater) on EBMS server (documents provided by BLC Contractor). Provide means to access this information using intuitive operator

interaction (quick links from relevant system graphics). Install and link all as-built network diagrams to specific system web page (provided by BLC Contractor). Install and link all as-built HVAC as-built ductwork and piping plans to specific floor plan graphic (provided by A/E). The intent of this requirement is to give the operator a way to access product and as-built information from the associated system web page (e.g. AHU system). Upon successful completion of acceptance testing, submit a minimum of two archive copies of all accepted versions of source code and compiled code for all application programs and data files on CD or DVD media.

- 1.15.4 Service: Submit name, address, and telephone number of company that will provide training and 7 day a week 24 hour a day warranty period service for the system.

2 PRODUCTS

- 2.1 Acceptable Manufacturers: Subject to compliance with requirements, provide EBMS software specific to: Siemens Industry, Apogee only.

- 2.2 General: Provide EBMS software as required for a complete installation. Except as otherwise indicated, provide manufacturer's standard system software as indicated by published information, designed and constructed as recommended by manufacturer. Provide an EBMS with the following indicated functional and constructed features.

2.3 Systems Description:

- 2.3.1 The existing EBMS is a complete system designed for use on Intranets and the Internet. The EBMS Contractor shall be responsible for coordination with the University of Miami IT staff to ensure that the EBMS will perform in the Owner=s environment without disruption to any of the other activities taking place on that WAN.

- 2.3.2 This Contractor shall provide all required system software to support a server/client architecture, designed around the open standards of web services. The BLC system will be configured with all software/hardware required to interface at the intranet level (Tier 1) using the ASHRAE 135 BACnet/IP protocol. The intent of the thin-client architecture is to provide the operator(s) complete access to the EBMS via a web browser. The thin-client web browser Graphical User Interface (GUI) is browser and operating system agnostic, meaning it supports modern browsers, and Microsoft Windows. (Automatic downloads to support specific applications are acceptable).

- 2.3.3 The EBMS consists of an existing communication network, existing server, with all points addressable and modifiable from server and any connected thin client machine. The EBMS is fully expandable with the addition of hardware and/or software.

- 2.3.4 Where necessary and as dictated in this section, servers are to be used for the purpose of providing a location for archiving system configuration data, historical data such as trend data, alarm reporting and operator transactions. All data stored will be stored in a standard data base platform.

2.4 System Performance:

2.4.1 Performance Standards: Any newly connected system shall conform to the following minimum performance standards. Systems shall be tested using manufacturer=s recommended hardware and software for operator workstation (server and browser for web-based systems).

2.4.1.1 Graphic Display: A graphic with 20 dynamic points shall display with current data within 10 sec.

2.4.1.2 Graphic Refresh: A graphic with 20 dynamic points shall update with current data within 10 sec.

2.4.1.3 Alarm Response Time: An object that goes into alarm shall be annunciated at the EBMS clients within 15 sec.

2.4.1.4 Multiple Alarm Annunciations: Each client on the network shall all receive alarms within 15 sec of the alarm event.

2.5 EBMS Architecture

2.5.1 The EBMS is designed for use on Intranets and the Internet. All networking technology used at the Tier 1 level is off the shelf, industry standard technology fully compatible with other UM provided network equipment.

2.5.2 The EBMS supports up to 25 simultaneous users.

2.5.3 The primary components of the system is the EBMS operations and historical server located at the highest level of the network architecture. The EBMS network shall, at a minimum, be comprised of the following:

2.5.3.1 One Desktop Operator PCs fixed desktop located at **XXXXX** coordinated by the Owner.
CONSULTANT TO COORDINATE DESKTOP PC REQUIREMENTS AND LOCATION WITH UM PROJECT MANAGER.

2.5.3.2 Network processing, data storage and communication equipment.

2.5.3.3 Intelligent and addressable elements and end devices.

2.5.3.4 Third-party equipment interfaces.

2.5.3.1 EBMS Integration Capabilities: The EBMS system has been designed around an open architecture with the capabilities to support a multi-protocol environment. To accomplish this effectively, the system is capable of utilizing the following standard protocols: High speed Ethernet communication using TCP/IP protocol.

- 2.5.3.2 BACnet/IP communication according to the latest ANSI/ASHRAE 135-BACnet standard.
- 2.5.3.3 The system will also support all standard HVAC communication protocols to integrate a wide variety of third-party devices. (*Lon RS485, Modbus/IP, WEB services*).
- 2.5.4 Remote Building Interfaces: This Contractor shall integrate real-time data from the BLC system supplied by other trades as required using BACnet/IP as the standard means of integration. The EBMS system shall include the necessary hardware equipment and software to allow data communications between the EBMS and systems supplied by the specific BLC Vendor. The 3rd party vendor contractor supplying other systems shall provide the necessary hardware and software and shall cooperate fully with this contractor (also known as the Control Systems Integrator) in a timely manner at their cost to ensure complete data integration. It shall be the responsibility of this Contractor to coordinate all trades to ensure all aspects of integration have been achieved.
- 2.6 Operator Interface Software:
- 2.6.1 General: The EBMS operator interface shall make use of colors, graphics, icons, embedded images, animation, text based information and data visualization techniques to enhance and simplify the use and understanding of the EBMS by authorized users.
- 2.6.2 User access to the EBMS is protected by a flexible and Owner re-definable software-based password access protection system. Password protection is multi-level and partitionable to accommodate the varied access requirements of the different user groups. Update access privileges for each authorized user and provide the means to establish general password groups to which an individual will then be assigned. Once assigned to the group, each individual will assume all the capabilities and restrictions of that group. Provide the means to provide on-line management of password access under the control of a master password and coordinate with UM Facilities for each project.
- 2.6.3 The operator interface incorporates functions including, but not necessarily limited to, the following:
- 2.6.3.1 User access for selective information retrieval and control command execution.
- 2.6.3.2 Monitoring and reporting.
- 2.6.3.3 Alarm, non-normal, and return to normal condition annunciation.
- 2.6.3.4 Operator override and adjust control actions.
- 2.6.3.5 Information archiving, manipulation, formatting, display and reporting.
- 2.6.3.6 On-line access to system as-built control diagrams, sequence of operation and product manuals.

- 2.6.3.7 Means for the controlled re-programming, re-configuration of EBMS operation and for the manipulation of EBMS database information.
- 2.6.3.8 Producing reports and displays making use of simple English language descriptions and readily understood acronyms, abbreviations and the like to assist user understanding and interpretation. All text naming conventions shall be consistent in their use and application throughout the EBMS and shall be consistent with current UM naming standards.

2.6.1 Client Operator Workstation :(OWS)

CONSULTANT TO COORDINATE DESKTOP PC REQUIREMENTS AND LOCATION WITH UM PROJECT MANAGER.

- 2.6.1.1 The client fixed OWS shall provide the primary means of communication with the EBMS from within the facility and shall be used for all building management operations, engineering, management, audit, reporting and other related functions.
- 2.6.1.2 Provide a commercially available desktop PC with Microsoft Windows operating system (Windows 7 or later version), standard engineering tool software, required cables, LCD backlit display and a full-featured keyboard. The OWS shall connect to the building LAN network and provide the local operator with a standard WEB based interface. The OWS shall not require any special database uploads/downloads and shall automatically synchronize database info when connected to EBMS server. Provide a user-friendly, English language-prompted interface for quick access to system information, not codes requiring look-up charts.
- 2.6.1.3 The hardware platform for operator workstations shall, at a minimum consist of:
- 2.6.1.3.1 PC processor with minimum 64-bit word structure
- 2.6.1.3.2 Minimum 2 Ghz processor speed.
- 2.6.1.3.3 Minimum 8 GB of RAM.
- 2.6.1.3.4 Hard drive with a minimum of 500 GB of usable space.
- 2.6.1.3.5 Removable high-speed data storage and export device(s) such as Read/Write CD ROM or equal
- 2.6.1.3.6 Two USB ports in addition to those used for keyboard and mouse.
- 2.6.1.3.7 Full ASCII keyboard and digital Mouse with USB connections.
- 2.6.1.3.8 10/100 Mbps Ethernet NIC (network interface card).

2.6.1.3.9 Full color, flat screen LCD monitor, minimum 17 inches diagonal screen, minimum 1280 x 1024 resolution, 0.26 or better dot pitch and minimum 120 Hz refresh rate

2.6.1.3.10 Full color laser printer as required for the functional requirements and duty of the application.

2.6.1.3.11 Connection of the OWS to the network shall not interrupt nor interfere with normal network operation in any way, prevent alarms from being transmitted to server or preclude centrally initiated commands and system modification.

2.6.1.3.12 OWS access to EBMS system shall be password-controlled.

2.6.1.4 Provide UPS for OWS. UPS shall maintain control upon loss of normal power and where applicable, until emergency power supply is brought on line.

2.6.1.4.1 Select UPS for minimum of 30 minutes backup time for load connected.

2.6.1.4.2 Upon sensing loss of normal power, transfer time shall be 8 milliseconds maximum.

Operating Temperatures: 0 to 104°F
Relative Humidity: 0 to 95% RH, non-condensing
Recharge Time: 8 hours, typical

2.6.2 EBMS Server Hardware:

2.6.2.1 The server hardware shall be upgraded as needed to support the additional project point database and historical storage requirements.

2.6.3 Navigation Screens:

2.6.3.1 The system shall display multiple navigation trees or graphical screens to aid the operator in navigating all systems and points connected.

2.6.4 Remote Notification:

2.6.4.1 Shall allow enunciation of Alarm Status, and System Event information to various notification devices such as alphanumeric pagers, smart phones, e-mail, and cell phones via text messaging services.

2.6.4.2 Alarm processing shall be a coordinated effort between the EBMS Contractor and the BLC Contractor. This contractor shall coordinate all alarm settings with the BLC Contractor and Owner.

- 2.6.4.3 Alarms shall be processed within the EBMS environment using real time data obtained directly from the BLC system. The alarm management portion of the operator interface software shall, at a minimum, provide the following functions.
- 2.6.4.3.1 Provide an audit trail on server hard drive for alarms by recording user acknowledgment, deletion, or disabling of an alarm. The audit trail shall include the name of the user, the alarm, the action taken on the alarm, and a time/date stamp and be stored in an activity log for long term storage and future access.
- 2.6.4.3.2 The EBMS shall annunciate diagnostic alarms indicating system failures and non-normal operating conditions.
- 2.6.5 Notification Messages:
- 2.6.5.1 Must allow for the configuration of the level of detail included in a remote notification message from concise to verbose, in the alarm message sent to each contact person.
- 2.6.5.2 A user-defined delay may be set to wait a period of time after the point goes into alarm before the notification is sent to the remote device.
- 2.6.5.3 Allow operators to manually send instant messages to notification devices, independent of alarm activity and regardless of a device=s scheduled availability.
- 2.6.6 Notification Device Scheduling:
- 2.6.6.1 Each of the UM staff members may have several devices available for remote notification. Each of these devices may be assigned different availability schedules for notification, for example, matching HVAC zone mechanic=s availability schedule. This will allow contacts to be extremely mobile, by notifying the selected devices and personnel during set hours of the day.
- 2.6.7 Group Notification:
- 2.6.7.1 For ease of setup and notification, a collection of devices can be combined into a group of selected notification messages. Remote notification will notify all members within a group of selected notification messages.
- 2.6.8 Escalation Lists:
- 2.6.8.1 Devices and groups can be combined as stages in an escalation list.
- 2.6.8.2 With an escalation list, a notification message will be sent to each stage one at a time, after a user-defined delay for each stage.
- 2.6.8.3 Remote Notification will escalate to notify subsequent stages in the list if the current stage does not respond within the defined delay period.

- 2.6.8.4 Escalation can be stopped by a manual operator command, upon acknowledgement of the alarm, upon the point returning to normal, or an optional call-in feature to stop escalation via a phone.
- 2.6.9 Paging Service Providers:
 - 2.6.9.1 Allow operators to define local TAP-compliant alphanumeric paging and SMS service providers (Telelocator Alphanumeric Protocol)
- 2.6.10 Optimization:
 - 2.6.10.1 Remote notification will allow devices to combine alarm and system event messages, minimizing notifications received by devices.
 - 2.6.10.2 Remote notification shall operate regardless if an operator is logged on the EBMS system.
- 2.6.11 Archival (Historical) System:
 - 2.6.11.1 Provide a means of archiving, managing, processing and retrieving business critical data for a range of information management / reporting needs including analysis, compliance and management reporting.
 - 2.6.11.2 Application programs shall be specifically designed for installations with high data volumes, offline storage capabilities and significant client access flexibility.
 - 2.6.11.3 All archived data records shall be retained indefinitely utilizing online and offline archiving technologies.
 - 2.6.11.4 Provide storage for the following types of electronic data:
 - 2.6.11.4.1 Trend data with change of value (COV) filtering capability: Point=s values are generated by control and monitoring systems when the value changes by a specified amount.
 - 2.6.11.4.2 Interval Data: Point values are generated by control and monitoring systems on a predefined interval.
 - 2.6.11.4.3 Summary: Point values are calculated at regular intervals based on the values of another point residing in the archival system or calculated result of a formula. An example of a summary point would be the daily maximum temperature of one day's worth of 15-minute samples or the average watts/sq.ft. value of a typical day.
- 2.6.12 Alarm Management:
 - 2.6.12.1 Alarm Routing shall allow the user to send alarm notification to selected printers or workstation location(s) based on time of day, alarm severity, or point type.

- 2.6.12.2 Alarm Notification shall be presented to each workstation in a tabular format application, and shall include the following information for each alarm point: name, value, alarm time & date, alarm status, priority, acknowledgement information, and alarm count. Each alarm point or priority shall have the ability to sound a discrete audible notification.
- 2.6.12.3 Alarm Display shall have the ability to list & sort the alarms based on alarm status, point name, ascending or descending alarm time.
- 2.6.12.4 Directly from the Alarm Display, the user shall have the ability to acknowledge, silence the alarm sound, print, or erase each alarm. The interface shall also have the option to inhibit the erasing of active acknowledged alarms, until they have returned to normal status. The user shall also have the ability to command, launch an associated graphic or trended graphical plot, or run a report on a selected alarm point directly from the Alarm Display.
- 2.6.12.5 Each alarm point shall have a direct link from the Alarm Display to additional user-defined point informational data. The user shall have the ability to also associate two real-time electronic annotations or notes to each alarm.
- 2.6.12.6 Alarm messages shall be customizable for each point, or each alarm priority level, to display detailed instructions to the user regarding actions to take in the event of an alarm. Alarm messages shall also have the optional ability to individually enunciate on the workstation display via a separate pop-up window, automatically being generated as the associated alarm condition occurs. The system shall have the ability to modify the priority text based on operator preference.
- 2.6.12.7 It is the intent of this specification to limit all alarm processing to within the EBMS environment. Alarm processing within the BLC is not permitted.
- 2.6.12.8 The operator shall have the ability to inhibit any alarm. The inhibit action shall be recorded in the system activity log.
- 2.6.12.9 All alarm message events shall be configured to print upon a request from the operator.
- 2.6.13 Reports:
- 2.6.13.1 Reports shall be generated and directed to one or more of the following: user interface displays, printers or archive files at the user's option. Refer to Part 3 Execution section for a list of project required reports.
- 2.6.14 System Configuration & Definition:
- 2.6.14.1 A Collapsible tree, dynamic system architecture diagram/display application of the site-specific EBMS architecture showing status of controllers, PC workstations and networks shall be provided. This application shall include the ability to add and

configure workstations, Building Controllers, as well as 3rd party integrated components. Symbols/icons representing the system architecture components shall be user-configurable and customizable, and a library of customized icons representing 3rd party integration solutions shall be included. This application shall also include the functionality for real-time display, configuration and diagnostics connections to Building Controllers.

2.6.15 Dynamic Color Graphics:

- 2.6.15.1 Provide means to generate an unlimited number of graphic displays. This contractor is responsible for all building system graphics, and shall update the UM site map with new building specific links. The contractor shall also submit sample graphics for review by the Engineer and Owner.
- 2.6.15.2 The operator interface shall allow users to access the various system schematics and floor plans via a graphical penetration scheme, menu selection, point alarm association, or text-based commands. Graphics software shall permit the importing of AutoCAD or scanned pictures for use in the graphics package. The penetration hierarchy shall start with the campus building map, building site graphic, proceed to a multi-floor building graphic, then to an individual floor, and then to a specific system.
- 2.6.15.3 Dynamic temperature values, humidity values, flow values and status indication shall be shown in their actual respective locations within the system schematics or graphic floor plan displays, and shall automatically update to represent current conditions without operator intervention and without pre-defined screen refresh rates.
- 2.6.15.4 Provide the user the ability to display real-time point values by animated motion or custom picture control visual representation. Animation shall depict movement of mechanical equipment, or air or fluid flow. Picture Control shall depict various positions in relation to assigned point values or ranges. A library (set) of animation and picture control symbols shall be included within the operator interface software graphics application. Animation shall reflect, ON or OFF conditions, and shall also be optionally configurable for up to five rates of animation speed.
- 2.6.15.5 Sizable analog bars shall be available for monitor and control of analog values; high and low alarm limit settings shall be displayed on the analog scale. The user shall be able to "click and drag" the pointer to change the setpoint.
- 2.6.15.6 Provide the user the ability to display blocks of point data by defined point groups; alarm conditions shall be displayed by flashing point blocks.
- 2.6.15.7 Equipment state or values can be changed by clicking on the associated point block or graphic symbol and selecting the new state (on/off) or setpoint.
- 2.6.15.8 State text for digital points shall be user-defined up to eight characters.

2.6.15.9 Colors shall be used to indicate status and the status of the equipment changes including alarm states. The state colors shall be user definable.

2.6.15.10 Advanced linking within the Graphics application shall provide the ability to navigate to outside documents (e.g., .doc, .pdf, .xls, etc.), Internet web addresses, e-mail, external programs, and other workstation applications, directly from the Graphics application window with a mouse-click on a customizable link symbol.

2.6.15.11 The Windows environment of the PC operator workstation shall allow the user to simultaneously view several graphic pages at one time to analyze total building operation or to allow the display of a graphic associated with an alarm to be viewed without interrupting work in progress.

2.6.16 System Activity Log

2.6.16.1 The system shall maintain a log of all operator activity, system messages, alarms and alarm acknowledgments.

2.6.16.2 Operator activity is defined as any action by an operator such as changing the value of an application parameter, modifying a program, acknowledging an alarm, logging on, logging off, etc. Any change in the system caused by operator action shall be part of the log. The log shall include the event, the time of the event, the part of the system affected, and an identification of the operator and the OWS from which the change was made.

2.6.16.3 When the activity deals with a value change, both the original and new values shall be part of the event record.

2.6.16.4 The Activity Log shall be exportable to a report format that is printable.

2.6.16.5 Only the System Administrator shall be able to modify the historical event log.

2.6.16.6 The Activity Log shall have a search function with assignable criteria to identify subsets of the activity log such as all points placed under manual control, etc.

2.6.17 Schedules:

2.6.17.1 The system shall provide multiple schedule input forms for automatic time-of-day scheduling and override scheduling of EBMS operations. All scheduling applications shall reside within the EBMS environment and not in the BLC system. At a minimum, the following schedule types shall be accommodated.

2.6.17.1.1 Weekly schedules

2.6.17.1.2 Temporary override schedules

2.6.17.1.3 Special "Only Active If Today Is A Holiday" schedules

2.6.17.1.4 Monthly schedules

2.6.17.2 Schedules shall be provided for each system or sub-system in the EBMS. Each schedule shall include all commandable points residing within the BLC system. Each point may have a unique schedule of operation relative to the system use schedule, allowing for sequential starting and control of equipment within the system. Scheduling and rescheduling of points shall be accomplished easily via the system schedule spreadsheets.

2.6.17.3 Monthly calendars for a 12-month period shall be provided that allow for simplified scheduling of holidays and special days in advance. Selection of holidays and special days shall automatically reschedule equipment operation as previously defined on the weekly schedules.

2.7 Microsoft Office Integration:

2.7.1.1 The Data Management system includes the following Microsoft Office Integration:

2.7.1.2 Microsoft Excel Add-in to connect as a client application and retrieve data.

2.7.1.3 Points and groups available to users for access via Excel. Access is restricted for data records not available to specific users.

2.7.1.4 Allows users to retrieve data and launch Excel Graphic functions.

2.7.1 Energy Monitoring and Control:

2.7.1.1 The utility data management/reporting system supports all utility consumption and demand data information.

2.7.1.2 Supports both English and SI units for utility demand/consumption.

2.7.1.3 Provides a user interface to add/remove utility data and other configuration information.

2.7.1.4 Provides reports in HTML format.

2.7.1.5 Provides automated checks and messaging for missing/invalid data.

2.7.1.6 Provides a graphical user interface for creating, viewing and managing reports.

2.7.1.7 Reports can be run automatically on a scheduled EBMS or manually on demand.

2.7.1.8 Scheduled report output options include printers or electronic file.

2.7.1.9 Provides utility data rollups from multiple meters.

- 2.7.1.10 Provides multi-level; secure access to data and functions using user accounts.
- 2.7.1.11 The utility data management system/reporting system is capable of operating independently of the BLC system.
- 2.7.1.12 User access to the utility management system is supported without requiring user access to the BLC system or its graphical user interface.
- 2.7.1.13 Provide the following utility data organizational features:
- 2.7.1.13.1 Physical Meter Definition B Assign demand and consumption points from the data management system to meter objects. Meter object properties include meter name, account name, consumption data source, demand data source, meter rate, and energy type.
- 2.7.1.13.2 Virtual Meter Definition B Create a non-physical meter from a mathematical expression using other virtual meters or physical meters. Virtual meter objects include Meter Name, account name, meter rate, energy types and meter formula.
- 2.7.1.13.3 Meter Grouping B A graphical user interface to group meters by function, use, or physical layout without custom programming. The meter grouping hierarchy shall contain at least three levels and include parameters such as group name, group function, group physical area, and group account number.
- 2.7.1.13.4 Meter Disabling B A capability to temporarily disable meters from inclusion in reports without custom programming.
- 2.7.1.13.5 Definitions - Users shall be able to define accounts, area types, area functions, energy types, energy units, average rates, holidays and service providers using a graphical user interface.
- 2.7.1.13.6 Rates - User shall be able to define multiple average rates for multiple utility types. Average rates shall be capable of being updated daily.
- 2.7.1.14 Provide the following Utility Data Report types and functions:
- 2.7.1.14.1 Demand Profile Reports B Rollups of utility demand displayed in 3D, XY or YZ charts. Demand can be single meter values or rollups of multiple meters or meter groupings as required.
- 2.7.1.14.2 Average Demand Reports B Average utility demand over a specified period for various day types or groups of days. Demand can be single meter values or rollups of multiple meters or meter groupings as required.
- 2.7.1.14.3 Peak Demand Reports B Peak utility demand over a specified period for various day types or groups of days. Demand can be single meter values or rollups of multiple meters or meter groupings as required.

- 2.7.1.14.4 Consumption Reports B Provides daily reporting of utility consumption for all utility types. Consumption can be based on a single meter value or rollups of multiple meters or meter groupings as required. Consumption reports can have graphical and tabular information.
- 2.7.1.14.5 Allocation Reports B Provides utility cost and consumption allocation. Allocation reports can be run for any level of meters or groups as required. Allocation reports include both report period values, fiscal year to date values and cost per unit of area.
- 2.7.1.14.6 Allow reports to be generated at any level of meters including virtual meters, meters, meter groupings or group groupings. Reports at higher levels will roll up demand/consumption for groups/meters within their groups.
- 2.7.1.14.7 Provide reports for any date range available in the data management system. The data management system shall provide an informative message is data is off-line and needs to be brought on-line.
- 2.8 BACnet Communications: The EBMS uses the UM Wide Area Network (WAN) for communication to the BLC system. The communication protocol between the server and the Building Level Controllers shall be BACnet/IP. Proprietary networks (networking between buildings and central server) and proprietary protocols are not acceptable. The EBMS shall act as the primary BBMD and shall limit BACnet data traffic to within the building level network until a remote request for information is requested or when a message must be transmitted outside the building level network.
- 2.9 System Security:
- 2.9.1 User access is secured using individual security passwords and user names.
- 2.9.2 Passwords shall restrict the user to the objects, applications, and system functions as assigned by the system manager.
- 2.9.3 User Log On/Log Off attempts shall be recorded in system activity log.
- 2.9.4 The system shall protect itself from unauthorized use by automatically logging off following the last keystroke. The delay time shall be user-definable.
- 2.10 Building Level Controllers (BLC) (Provided under BLC Contract)
- 2.10.1 The BLC shall perform the function of managing all building system functions, including but not limited to: communications, global programs, database management, and overall supervision.

3 EXECUTION

3.1 General:

3.1.1 Coordinate timely delivery of materials and supervise activities of other trade contractors. The associated building BLC vendor will provide up to **[40 hrs]** of system support.

CONSULTANT SHALL COORDINATE TRAINING REQUIREMENTS WITH UM PROJECT MANAGER

3.2 Contractor responsibility matrix:

3.2.1 The following matrix delineates AP@ as primary and AS@ as secondary, the scope of work for the EBMS Contractor, BLC Contractor, Engineer and the Owner.

Task	BLC Contractor	EBMS Contractor	Engineer	Owner
Enterprise System		P		S
Building Level Hardware / Software Application Engineering	P	S		
Building Level Control System Shop Drawings				
Production	P	S		
Review/Approval		S	P	S
WEB Page Development (Active Server)		P		S
Web Services Management		P		S
Database Creation				
Building Level	P	S		
Enterprise Level	S	P		
Security Authorization				
Building Level	P			S
Enterprise Level		P		S
Building to Enterprise Installation Verification	S	P		
Hardware IP Address	S	S		P
Alarms	S	P		S
Control	P	S		S
Campus Communication Link	S	P		
Owner Training				
Building Level	P	S		S
Enterprise Level	S	P		S
Software Licensing				
Building Level	P			S
Enterprise Level		P		S
Software Upgrades				
Building Level	P			S
Enterprise Level		P		S

- 3.3 Examine areas and conditions under which the EBMS is to be installed. Do not proceed with work until unsatisfactory conditions have been corrected in manner acceptable to installer.
- 3.4 Installation of EBMS:
- 3.4.1 General: All work shall be installed and operationally checked by factory-trained competent technicians skilled in the testing and adjustment of the specific manufacturer's devices and equipment.
- 3.5 Programming:
- 3.5.1 Point Naming: System point names shall be modular in design, allowing easy operator interface without the use of a written point index. Point Naming standard shall be agreed upon between Owner and Control System Integrator.
- 3.5.2 Software Programming:
- 3.5.2.1 Provide programming for the BLC system interfaces. This Contractor shall provide all other supervisory system programming necessary for the supervisory operation of the entire system.
- 3.5.3 Operator Interface:
- 3.5.3.1 Show terminal equipment information on a summary table. Provide dynamic information for each point shown.
- 3.5.3.2 The EBMS contractor shall provide all the labor necessary to install, initialize, start up, and troubleshoot all operator interface software and its functions as described in this section. This includes any operating system software, the operator interface database, and any third-party software installation and integration required for successful operation of the operator interface.
- 3.5.3.3 Contractor shall provide necessary programming to create all reports, trending files, schedules, graphics, alarm reports, and system specific as-built plan links.
- 3.6 Servers:
- 3.6.1 Server is an existing virtual machine managed by UM.
- 3.7 Programming of the EBMS:
- 3.7.1 Schedules: The Contractor shall obtain operational schedules for the controlled equipment from the Owner. Submittal data relevant to operational schedules shall be forwarded from the Contractor to the Owner and Engineer. Upon receipt of approval, the Contractor shall proceed with installation, setup, and check out of the various

- control and monitoring systems. Having completed component and system installation, the Contractor shall submit a written request to the Engineer to inspect and approve their satisfactory operation.
- 3.7.2 **Graphics:** Provide only the color graphic software package satisfying the requirements of this specification. All building level graphics shall be generated for project.
- 3.7.2.1 Provide a color graphic system flow diagram display for each system with all points as indicated on the point list. Provide a color graphic display for each floor in the facility. Indicate each HVAC zone, color coded to indicate zone values and status. User shall be able to access the various system schematics and floor plans via a graphical penetration scheme and/or menu selection starting with a site plan, building riser, or floor plan. User shall be able to penetrate from floor plan to associated HVAC system or room terminal unit.
- 3.7.2.2 Create color graphic floor plan displays and system schematics for each piece of mechanical equipment, including, but not limited to, air handling units, chilled water systems, hot water systems, and room level terminal units. All system graphics shall include links to as-built control diagrams, sequenced, and product technical literature.
- 3.7.2.3 The operator interface shall allow users to access the various system schematics and floor plans via a graphical penetration scheme, menu selection, point alarm association, or text-based commands. Graphics software shall permit the importing of AutoCAD or scanned pictures for use in the system.
- 3.7.2.4 Dynamic temperature values, humidity values, flow values and status indication shall be shown in their actual respective locations within the system schematics or graphic floor plan displays, and shall automatically update to represent current conditions without operator intervention and without pre-defined screen refresh rates.
- 3.7.2.5 Display real-time point values by animated motion or custom picture control visual representation wherever possible. Animation shall depict movement of mechanical equipment, or air or fluid flow. Picture Control shall depict various positions in relation to assigned point values or ranges. Animation shall reflect, ON or OFF conditions, and shall also be optionally configurable for up to five rates of animation speed.
- 3.7.2.6 Sizable analog bars shall be available for monitor and control of analog values; high and low alarm limit settings shall be displayed on the analog scale. The user shall be able to "click and drag" the pointer to change the setpoint. Setpoints and controlled variables shall be positioned on graphic adjacent to each other.
- 3.7.2.7 Establish linked blocks of miscellaneous program point data by defined point groups; alarm conditions shall be displayed by flashing point blocks.
- 3.7.2.8 Equipment state or values shall be changed by clicking on the associated point block or graphic symbol and selecting the new state (on/off) or setpoint.

- 3.7.2.9 Colors shall be used to indicate status and change as the status of the equipment changes. The state colors shall be user definable.
- 3.7.2.10 Real time performance levels shall be represented in all graphics (floor plan and systems). Green shall indicate optimal performance and red shall be indicative of a performance failure requiring investigation and correction.
- 3.7.2.11 Link all BLC system provided as-built control diagrams, sequences and product technical data. Link all HVAC duct plans and piping plans to their respective floor plans.
- 3.7.3 The BLC contractor shall work with the CSI to implement long term trending for all physical input and output points and all set-points. The initial trend interval settings shall be set to 15 minutes. In addition, the Contractor shall increase the resolution of all control loop trending to every 5 minutes during the testing/acceptance phase (minimum of 2 weeks). Control loop trending shall include controlled variable, setpoint, and output from actuated device. Coordinate all trending requirements with the CSI.
- 3.7.4 Alarming:
- 3.7.4.1 The BLC contractor shall work with the CSI Contractor to define the specific system reactions for each point. Alarms shall be enhanced and prioritized to minimize nuisance reporting and to speed operator response to critical alarms. A minimum of six priority levels shall be provided for each point. The Contractor shall initially define all point priority levels for handling of all system alarms. Users shall have the ability to manually inhibit alarm reporting for each point. All system logic needed to support the alarm reactions shall be developed under this section.
- 3.7.4.2 Certain advanced features and functional requirements of this section cannot be achieved via standard alarming (Intrinsic Alarming) functionality alone). Coordination and implementation will be required by both the BLC and CSI to achieve the required results. The BLC contractor shall be responsible for the creation of any required Event Enrollment Objects at the building level that are required for Enhanced Alarming implementation (Algorithmic Change Reporting). Through the use of these Event Enrollment Objects and Algorithmic Change Reporting the following minimum event type algorithms shall be available:
- 3.7.4.2.1 CHANGE_OF_BITSTRING
 - 3.7.4.2.2 CHANGE_OF_STATE
 - 3.7.4.2.3 CHANGE_OF_VALUE
 - 3.7.4.2.4 COMMAND_FAILURE
 - 3.7.4.2.5 FLOATING_LIMIT
 - 3.7.4.2.6 OUT_OF_RANGE
 - 3.7.4.2.7 BUFFER_READY
 - 3.7.4.2.8 CHANGE_OF_LIFE_SAFETY
 - 3.7.4.2.9 UNSIGNED_RANGE

- 3.7.4.3 In conjunction with the algorithmic change reporting, intrinsic reporting of alarm may be required to indicate certain required conditions. Again, detailed coordination will be required between the BLC and the CSI to implement this strategy. The BLC shall ensure the local points are created with the required intrinsic reporting features enabled and allow the CSI to adjust the level of these features via the BACnet standard Write Property Service. E.g. High Limit of a temperature sensor. The fact the point is alarm able shall be set up by the BLC but the actual level of alarm could be set or adjusted by the CSI.
- 3.7.4.4 The BLC contractor shall work with the CSI Contractor to create enhanced alarm programs for all applicable system points. These points shall be programmed for appropriate seasonal high or low alarm limits. Enhanced alarm programs shall prevent nuisance alarms from occurring when the associated system has been deactivated. For example: a) All zone alarms shall be disabled when the associated AHU serving these zones has been disabled. b) Alarms shall occur only while systems are active and being supplied with chilled/hot water or steam at normal operating temperatures and pressures. Alarms shall have accurate descriptions and response instructions, so that alarms may be quickly associated with an appropriate graphic display. All system logic needed to support the alarm enhancement strategies shall be developed under this section.
- 3.7.4.5 Coordination will be required during the creation of any required Notification Class Objects. Notification Class Objects contain the information required for the distribution of alarm notifications across the BACnet System. Since these points most likely reside in the building level controllers the BLC will lead the creation of these objects. Again, the CSI will have the ability to make parameter adjustments on these objects via BACnet standard Write Property Services. This may include such adjustments as modifying the Recipient List of the Notification or any of the other modifiable parameters as outlined by the BACnet Standard.
- 3.7.4.6 To implement the suppression of Alarm generation and notification, Command Objects may be required. Again, the creation of any required Command Objects will be led by the BLC. Adjustment to the Command Objects can be made by the CSI. These CSI allowable modifications must adhere to the BACnet Standard.
- 3.7.4.7 Enhanced alarming shall include the following points:
- 3.7.4.7.1 All analog variables used within a control loop (PID). Alarms shall be based on a user defined offset of the established setpoint value and the feedback value. The user shall have the ability to adjust the offset and alarm delay.
- 3.7.4.7.1.1 As outlined in the BACnet Standard 13-2008; "Starting in the NORMAL state, if the value of the referenced property becomes greater than Setpoint_Reference + High_Diff_Limit for a period of time greater than the Time_Delay parameter, the Event Enrollment object sets the Event_State property to the HIGH_LIMIT state and generates a TO-OFFNORMAL transition. The Event Enrollment object generates a

TO-NORMAL transition and sets the Event_State property to NORMAL when the referenced property returns to a value less than Setpoint_Reference + High_Diff_Limit - Deadband for a period of time greater than the Time_Delay parameter. In each case, the event notification shall show an 'Event Type' of FLOATING_LIMIT. Starting in the NORMAL state, if the value of the referenced property becomes less than Setpoint_Reference - Low_Diff_Limit for a period greater than the Time_Delay parameter, the Event Enrollment object sets the Event_State property to the LOW_LIMIT state and generates a TO-OFFNORMAL transition. The Event Enrollment object generates a TO-NORMAL transition and sets the Event_State property to NORMAL when the referenced property returns to a value greater than Setpoint_Reference - Low_Diff_Limit + Deadband for a period of time greater than the Time_Delay parameter. In each case, the event notification shall show an EventType of FLOATING_LIMIT.”

- 3.7.4.7.2 All binary points used as equipment feedback and which have a corresponding ON/OFF command point.
- 3.7.4.7.3 All AHUs and associated energy sources (chilled water, hot water, steam, etc...).
- 3.7.4.7.4 All terminal units and associated AHUs: Disable all associated terminal unit alarms upon proof that the associated AHU is off.
- 3.7.4.8 Alarm reports and messages shall be directed to a user-defined list of operator devices or PCs based on time (after hour destinations) and/or based on priority.
- 3.7.4.9 In addition to the point's descriptor and the time and date, the Contractor shall create, print, display and store an alarm message for each point to more fully describe the alarm condition or to direct operator response. Alarm events may be configured to send an alarm message to a specified client e-mail address, cellular phone number via SMS text messaging
- 3.7.1 Point Control: Provide all points as listed on vendor provided point list. All BLC system points shall be programmed to allow EBMS override.

CONSULTANT SHALL CUSTOMIZE SUMMARY REPORTS TO REFLECT ACTUAL SYSTEMS AND APPLICATIONS

- 3.7.2 Reports: Reports shall be developed and generated as described below. All reports shall be customized for the specific project and application. All system summary reports shall be linked to the specific system graphic, floor plan and/or home page as required.
 - 3.7.2.1 General system summary reports
 - 3.7.2.1.1 All points in the BLC.
 - 3.7.2.1.2 All points in a user-defined group of points including per system log reports.
 - 3.7.2.1.3 All points currently in alarm in the BLC system.

3.7.2.1.4 All schedules.

3.7.2.1.5 All points under override condition.

3.7.2.2 System summary reports.

3.7.2.2.1 Include an AHU terminal unit summary report for each AHU that serves multiple terminal units. The summary report shall include the following information

Air Terminal Summary Report									
Room #	CFM Actual	CFM Stpt	% Error	Min CFM Stpt	Max CFM Stpt	Reheat Valve Command	Htg Stpt	Temp Actual	Clg Stpt
TOTAL									

3.7.2.2.2 Include a chilled water summary report for each building. The summary report shall include the following information

Chilled Water Summary Report							
AHU #	Supply Air Actual	Supply Air Stpt	CHW Coil Ret Temp ¹	CHW Coil Sup Temp ²	CHW Valve Command	CHW Valve Feedback	% Error

Note 1: Obtained directly from the associated AHU return water temperature sensor

Note 2: Obtained from the main building chilled water supply sensor

3.7.2.2.3 Include a heating hot water summary report for each building. The summary report shall include the following information

Hot Water Summary Report		
AHU/Terminal #	Heating Coil Supply temp	Htg Valve Command

3.7.2.2.4 Include an AHU laboratory summary report for each AHU that serves multiple laboratories. The summary report shall include the following information

Air Terminal Summary Report										
Lab #	CFM Supply Actual	CFM General Actual	CFM Fume Actual	CFM Offset Stpt	CFM Offset Actual	% Error	Reheat Valve Command	Htg Stpt	Temp Actual	Clg Stpt
TOTAL										

CONSULTANT TO EDIT PER SPECIFIC PROJECT SYSTEMS BEING INSTALLED

3.8 Graphical Standard Guidelines: Reference Appendix B for additional guidelines and sample graphics.

3.8.1 Legend: The legend screen will show and define the color coding scheme for the graphics and provide instructions to help the operator with various viewing commands. There shall be links to the site map and previous screen links in the top left corner. Bottom of the page shall contain the following outdoor readings: Dry bulb, relative humidity and wet bulb and include time and date information.

3.8.2 Site Map: After initiating the building automation graphics the first screen to appear will be the UM Campus site map. The site map shall display all buildings and indicate buildings not connected/integrated to the EBMS as a gray object. The UM buildings connected to the EBMS shall be colored with one of two colors B red or green. The green colored buildings shall show the user that there are no alarms active in the building, while red color shall indicate that one or more of building systems are in an alarm mode.

3.8.2.1 In order to see the full name of each building the user shall be able to hover the cursor over the building icon (bringing up the full name of the building), this feature will only be assigned to the integrated buildings. Each building icon will act as an active link to transfer the user to the buildings home screen.

3.8.2.2 At the bottom of the screen will be displayed current outdoor air conditions (temperature, humidity), this information is acquired from a location coordinated by UM Facilities.

3.8.2.3 The bottom of the screen will also contain current time and date information.

3.8.2.4 Top left corner of the screen will have a link to the previous screen.

- 3.8.3 Home Screen: The building home screen shall provide the user with various building energy and building pressurization data. A picture of the building will appear in the upper left hand corner of the screen adding to the esthetic character of the graphic, the picture will not act as an active link.
- 3.8.3.1 Under the building picture shall be several links to building systems, floor plans, air systems, water systems, miscellaneous systems and/or energy reports as applicable to the project. When the Air Systems cell is activated, for example, it will expand and show all AHUs, EFs and standalone FCUs which serve the building. Floor plan cell will expand, listing links to all floors. The Water Systems cell will expand to show heating hot water system, chilled water system and/or domestic hot water system. The Energy report link will show current building energy data: Building kW, kWh, tons, kton-hr, Btu/h, Btu w/sqft, sqft/ton, or as installed. Miscellaneous Systems cell will expand to show all remaining systems having graphics which were not covered by previous cells (i.e. compressed air, vacuum, equipment alarms, etc).
- 3.8.3.2 The alarm bell located further below the building picture will be an indicator and an active link. Bell will have one of two colors green or red. Green color will inform the user that all building systems are operating normally, while a red color will notify the user that there are systems within the building which are in alarm mode. The alarm bell red color activation will be adjusted per user preference to trigger only if high priority alarms exist in the building. The bell alarm activation will be coordinated to correspond to building color on the site map. It will also allow for a direct link to the alarm management screen.
- 3.8.3.3 Energy demand gauges will display current energy consumption for each measured utility. The gauges scale and resolution will be adjusted to correspond to peak design conditions. The indicator arrows will show the same value as displayed in a cell below the gauge.
- 3.8.3.4 Top left hand corner of the screen will have two links to previous screen and the site map.
- 3.8.4 Large Area Floor Plan Graphic: When a link to a particular floor is selected, the screen will show an overall floor plan view divided into sections. This intermediate screen is necessary in larger buildings where detailed floor plan views with room numbers and sensors displaying room air conditions are not possible due to space limitations. In the case of a building with floor plans containing few rooms per floor, this screen can be omitted. The floor plan will accurately represent the as-built layout of rooms in the building.
- 3.8.4.1 The divisions of the partial floor plan sections should be based on the zones served by different air handling equipment whenever possible. If that strategy does not produce the desired effects, the second best option is to divide the floor plan into equal parts.

- 3.8.4.2 Each section shall have a link to take the user to a more detailed floor plan screen. In the bottom left hand corner of the screen are links to other floors arranged in a vertical tree. The user shall be able to link to any floor from this tree.
- 3.8.5 Floor Plan Section: The floor plan section screen shows the floor plan layout in more detail with room numbers and sensors displaying room environmental conditions. Each sensor and room number act as a link to the corresponding room system graphic. All sensors indicated space conditions shall be displayed including but not limited to: temperature, humidity, CO₂, etc...
- 3.8.5.1 The bottom left hand corner of the screen features links to different floors described previously, as well as a key plan of the sectioned view of the overall floor plan (if used). Each section acts as an indicator and a link. The user can move between section screens by selecting the appropriate link. Bottom of the page will have links to associated as-built HVAC and piping plans.
- 3.8.6 Office: When user selects a link to an office space (by clicking on a room sensor) the graphics screen will bring up a detailed view of the room air terminal and associated sensors. The Screen title block will list the room number (where thermostat is installed) and air terminal name. Supply airflow sensor will have the airflow, airflow set-point and velocity pressure listed. Zone temperature will be listed with effective/actual (after local adjustments) heating and cooling set-points and if the temperature deviates outside those set-points the point will go into alarm mode. A parameter list block will act as a link to all points not displayed on the screen (typically setup parameters, tuning parameters, timers, etc.). The user will have the ability to change all set-points and settings. All analog inputs will be read-only type points with the user having the option of taking the readings out of service. Bottom of the page will have links to associated as-built reference material.
- 3.8.7 General Lab: When user selects a link to a general lab space the graphics link will bring up a room with relevant air terminals (supply, general exhaust, fume, etc.) and their associated control points. Air terminals will have their respective tags displayed on their icons, (per as-built drawings). The air terminals command position and air terminal feedback will be listed next to each air terminal.
- 3.8.7.1 The screen title block will list the room number with the air valves.
- 3.8.7.2 The air change rate information shall be calculated and based on the room volume and the air flowing out or into the room. Positive rooms shall use the total supply and negative rooms shall use the total exhaust when calculating air changes per hour.
- 3.8.7.3 Zone temperature will have its effective/actual (after local adjustment) heating and cooling set-points listed, if temperature deviates outside those values the point will go into alarm mode.

- 3.8.7.4 All analog points will have their corresponding set-points displayed, the parameter list button will be a link to all settings not shown on the room screen. The user will be able to change all settings, and all analog and binary inputs will be read only points with the user having the ability to take them out of service.
- 3.8.8 Air Handling Unit Supply: AHU screen title will show the equipment name and location.
- 3.8.8.1 All analog points will have their corresponding set-points displayed on the equipment graphic. When the input values are outside their respective set-points, their cells will turn red to show the user that the reading is in an alarm state.
- 3.8.8.2 The user will be allowed to override all settings, all inputs will be read only with an option of taking their value out of service.
- 3.8.8.3 The outside air damper and return air dampers will have their % open value command and feedback (if applicable) displayed in their indicator cells. The supply air damper status shall be dynamical making the damper blades move with respect to feedback information.
- 3.8.8.4 Fan status will be shown by color coding the fan wheel green and dynamically spinning the fan wheel when the fan is ON, when fan is OFF the fan wheel will not spin and the fan wheel color will be blue. When fan is in alarm mode (feedback does not match command). When AHU is equipped with fan array, all fans shall be shown. VFD box above the fan will provide the user with active links to variable frequency drive integrated information. Supply fan VFD command cell will display the speed of the drive in 0-100%, if the VFD is allowed to exceed 60Hz during normal operation, 100% will correspond to the maximum speed the VFD is allowed to go to. Actual fan hz will be displayed.
- 3.8.8.5 Cooling/heating coil valve command indicator cells will display the % open command of valve full span and feedback value. Chilled water returning from the cooling coil will have its temperature displayed in the indicator cell.
- 3.8.8.6 Filter status will be indicated in the cell and shall flash red when in an alarm state. Filter DP device settings shall be included in graphic when pressure settings are set locally.
- 3.8.8.7 Low temperature alarm, high static alarm and smoke alarm indicator cells will have a green background and display ANormal@ when in normal mode, during alarm mode the cell background color will change to red and display will read AAlarm@.
- 3.8.8.8 Information used in discharge temperature reset control loop such as maximum zone temperature and humidity will be displayed in the corner of the screen.
- 3.8.9 Variable Fan Speed Exhaust System with Bypass Damper: Exhaust fan screen title will show the equipment name and location.

- 3.8.9.1 All analog inputs shall have their corresponding set-points listed either on the equipment graphic or in the system parameter box. When the input values are outside their respective set-points, their indicator cells will turn red to show the user that the reading is in alarm mode.
- 3.8.9.2 The user shall be allowed to override all settings, all inputs will be read only with an option of taking their value out of service.
- 3.8.9.3 The bypass dampers shall have their % open value and feedback displayed in their indicator cells. The damper status shall be dynamic by making the damper blades move when damper is closed and open when damper is open.
- 3.8.9.4 Fan status will be shown by dynamically spinning the fan wheel when the fan is ON, when fan is OFF the fan wheel will not spin. When fan is in alarm mode (feedback does not match command) the data point will be red. When AHU is equipped with fan array, all fans shall be shown. VFD box above the fan will provide the user with active links to variable frequency drive integrated information. Supply fan VFD command cell will display the speed of the drive in 0-100%, if the VFD is allowed to exceed 60Hz during normal operation, 100% will correspond to the maximum speed the VFD is allowed to go to. Actual fan hz will be displayed.
- 3.8.9.5 Low static alarm indicator cells will have a green background and display `ANormal@` when in normal mode, during alarm mode the cell background color will change to red and display will read `Alarm@`.
- 3.8.10 Chilled Water and Hot Water System: Chilled water system screen title shall show the system name and location.
- 3.8.10.1 All analog inputs shall have their corresponding set-points listed either on the equipment graphic or in the system parameter box. When the input values are outside their respective set-points, their indicator cells shall turn red to show the user that the reading is in alarm mode.
- 3.8.10.2 The user shall be allowed to override all settings; all inputs will be read only with an option of taking their value out of service.
- 3.8.10.3 Valves will have their % open value and feedback displayed in the indicator cells. The pump isolation valve status will be indicated by indicator cell.
- 3.8.10.4 Pump status will be shown by dynamically spinning the impeller wheel when the pump is ON, when pump is OFF the impeller wheel will not spin. Pump status will be derived from the output power reading of the VFD. When pump is in alarm mode (feedback does not match command) the data point will be red. VFD box above the pump will provide the user with active links to variable frequency drive integrated points. Pump VFD command cell will display the speed of the drive in 0-100% increments. Indicator cell displaying pumps lead-lag (primary/standby) listing will be shown below each pump, as the pump rotation occurs, the indicator cells will display updated lead lag

(primary/standby) status in each cell.

3.8.10.5 Include flows and energy data when applicable.

3.8.11 Variable Frequency Drive: Upon activation of a VFD link on any of the equipment screens the user shall be directed to the VFD display screen. The name of the associated equipment will be displayed in the title block of the screen.

3.8.11.1 All available analog and binary inputs will be shown with appropriate names and units. When VFD is offline all of the indicator cells will turn black.

3.8.11.2 Additional graphics not described in this section shall be developed and designed as above. The above sections describe the design intent of the graphics package.

3.9 Owner's Instructions:

3.9.1 During system startup and at such time as acceptable performance of the EBMS equipment and software has been established, the Contractor shall provide on-site operator instruction. This instruction shall be performed during normal working hours and shall be conducted by a competent representative of the Contractor familiar with the system's software, hardware and accessories. The Contractor shall maintain a roster of all attendees at all training sessions.

3.9.2 Training Requirements:

3.9.2.1 At a time mutually agreed upon during system training as stated above, the Contractor shall give **[40]** hours of onsite instruction to the Owner's designated personnel on the operation of all software within the EBMS and describe its intended use with respect to the programmed project specific functions specified. The following sections describe the training intent as it relates to job specific function operator levels.

COORDINATE TRAINING REQUIREMENTS WITH UM PROJECT MANAGER.

3.9.2.2 Casual User Operators:

3.9.2.2.1 Proficiently operate the system.

3.9.2.2.2 Understand EBMS system architecture and configuration.

3.9.2.2.3 Understand EBMS system components.

3.9.2.2.4 Operate the workstation and peripherals.

3.9.2.2.5 Log on and off the system.

3.9.2.2.6 Access graphics, point reports, and logs.

3.9.2.2.7 Adjust and change system set points, time schedules, and holiday schedules.

3.9.2.2.8 Recognize malfunctions of the system by observation of the printed copy and graphical visual signals.

3.9.2.2.9 Understand system drawings and Operation and Maintenance manual.

3.9.2.2.10 Access data from EBMS controllers.

3.9.2.3 Advanced Operators:

- 3.9.2.3.1 In addition to the above functions.
- 3.9.2.3.2 Make and change graphics on the workstation.
- 3.9.2.3.3 Create, delete, and modify alarms, including annunciation and routing of these.
- 3.9.2.3.4 Create, delete, and modify point trend logs and graph or print these both on an ad-hoc EBMS s and at user-definable time intervals.
- 3.9.2.3.5 Create, delete, and modify reports.
- 3.9.2.3.6 Add, remove, and modify systems physical points.
- 3.9.2.3.7 Create, delete, and modify system displays, both graphical and others.
- 3.9.2.3.8 Perform EBMS controller unit operation and maintenance procedures.
- 3.9.2.3.9 Perform workstation and peripheral operation and maintenance procedures.
- 3.9.2.3.10 Perform EBMS system diagnostic procedures.
- 3.9.2.3.11 Configure hardware including PC boards, switches, communication, and I/O points.
- 3.9.2.3.12 Maintain, calibrate, troubleshoot, diagnose, and repair hardware.
- 3.9.2.3.13 Adjust, calibrate, and replace system components.

3.9.3 System Managers/Administrators:

- 3.9.3.1 In addition to the above functions.
- 3.9.3.2 Maintain software and prepare backups.
- 3.9.3.3 Interface with job-specific, third-party operator software.
- 3.9.3.4 Add new users and understand password security procedures.

- 3.9.4 Provide at least 14-day notice to Owner and Engineer of training dates. Submit a training plan including scheduled dates and times for Owner and Engineer approval at least 4 weeks in advance.

COORDINATE ALL TRAINING REQUIREMENTS WITH UM PROJECT MANAGER

- 3.10 System Verification: The manufacturer's authorized representative shall state in writing to the Engineer that the EBMS system is operating properly, all integration capabilities have been achieved, all project graphics are complete and all project reports have been configured, and Owner training has been accomplished.

3.11 Guarantee:

- 3.11.1 All components, parts, and assemblies shall be guaranteed against defects in material and workmanship for a period of one year after acceptance. Expressed warranties are conditionally based on the requirement that the items covered within the guarantee are used and maintained in accordance with the manufacturer's recommendations. Guarantee commences at time of acceptance. Acceptance shall not occur until the Owner's operators are able to use the EBMS and receive reliable information the project BLC system.

- 3.11.2 Contractor shall maintain all project software backup inventories within its local office site during the warranty period. All EBMS software, project-specific software, graphic software, database software, and firmware updates which resolve known software deficiencies shall be provided at no additional cost during the warranty period.

This chapter identifies criteria for the design of electrical systems in University of Miami (UM) buildings with the purpose of establishing minimum standards, acceptable to UM, to be used as the basis of design for UM Coral Gables Campus.

DIVISION 26 ELECTRICAL

- 26.1 General Requirements
 - 26.1.1 Submittals
 - 26.1.2 Workmanship requirements
- 26.2 Codes and Standards
 - 26.2.1 Electrical Design Standards
- 26.3 Design Criteria
 - 26.3.1 Building Energy Performance
 - 26.3.2 Lighting Control
 - 26.3.3 Electrical Systems Spare Capacity
- 26.4 Utility Coordination
 - 26.4.1 Short circuit calculations
 - 26.4.2 Service entrance
- 26.5 Distribution System
- 26.6 Electrical Rooms
- 26.7 Specific Electrical requirements (organized by CSI MasterFormat® 2013 Numbers & Titles)

26.1 General Requirements

All work shall be designed by a Professional Electrical Engineer licensed in the State of Florida.

Before the start of construction on new buildings and/or major renovations, the Contractor shall provide a drawing for each building floor level showing the coordination of all structural, architectural and MEP items. This includes, but is not limited to: Structural members, floor plates, architectural ceilings, soffits, smoke barriers, fire walls, vertical shafts, sleeves, fire dampers, HVAC ductwork and equipment, plumbing piping and equipment, fire protection piping and equipment, alarm systems, communications, electrical distribution and equipment, lighting, controls, BMS, lighting protection, security systems, etc.

UM Coral Gables Campus and UM Buildings electrical systems' design must comply with the following objectives:

1. Sustainable Design, reducing total building energy consumption, peak electrical demand and resistive losses whenever possible.
2. User comfort.
3. Ease of maintenance.
4. Flexibility to allow for major and minor alterations which will occur during the typical building's life span, without causing major disruptions to other areas of the building.
5. High level of integration between architecture and the engineering systems using the latest advancements in technology. This intent shall be extended to include the future evolution of automated office. Making this concept a reality requires a comprehensive design for engineering systems that goes beyond the requirements of the immediate building program.

6. Solutions with the best value considering a life cycle cost analysis to account for the total project cost.

The design of the electrical systems, in concert with other building components, shall produce a building that meets the programmed sustainability rating (LEED rating) of the specific project.

26.1.1 Submittals

Submittals shall include product data, samples, and shop drawings which are coordinated with all corresponding disciplines. The Design Professional must ensure that all submittals and shop drawings are coordinated with other disciplines.

26.1.2 Workmanship requirements

All work is to comply with NECA 1 and NECA 101.

26.2 Codes and Standards

26.2.1 Electrical Design Standards

The electrical systems shall comply with the requirements of the applicable authorities having jurisdiction and with the in-force edition at the time of the project of following codes and standards:

1. National Electrical Code (NFPA 70)
2. Florida Building Code in force at the time of the project; including all Referenced Standards.
3. National Fire Protection Association (NFPA) codes and standards.
4. IESNA: Illuminating Engineering Society of North America
5. IEEE: Institute of Electrical and Electronics Engineers

26.3 Design Criteria

26.3.1 Building Energy Performance

Electrical systems shall be designed in compliance with the Florida Building Code following the energy and performance goals necessary to achieve a LEED rating.

26.3.2 Lighting Control

1. Interior and exterior lighting shall be controlled with automatic control devices. Acceptable automatic control devices include:
 - a. Control device using a 365-day schedule, astronomical clock with automatic adjustments for daylight savings and leap year. Device shall have an independent program for areas of no more than 25,000 square feet but no more than one (1) floor. Provide 10 year power failure memory.

- b. An occupancy sensor which turns off the lights after 30 minutes of the space being unoccupied.
 - c. A signal from another control or alarm system that indicates the area is unoccupied.
 - d. In IT, storage and other rooms with the same pattern of utilization, the use of Digital Wall Switch Timer is preferred.
 - e. Use photo-sensor controls with exterior lighting, to insure that they are turned off when daylight is sufficient. Place photo-sensors so that they are not influenced by adjacent lighting.
2. Lighting control systems shall be controlled and programmed by the existing campus BMS using BACnet protocol.
 - a. The following lighting shall not require automatic control devices:
 - (1) Areas designed for 24-hour operation.
 - (2) Areas where patient care is rendered.
 - (3) Spaces where an automatic shutoff would endanger the safety or security of the room or building's occupants.
 3. Daylight harvesting, maintaining consistent lighting levels, shall be used whenever possible, using dimming or switching as per UM's program requirements.
 4. All classrooms and conference rooms shall receive dimmers. Provide no less than 2 zones and implement the daylight harvesting system for each room. These dimming systems shall be controlled and programmed by the existing campus BMS using BACnet protocol. Dimmers shall regulate voltage to maintain a constant light level with no visible flicker and with a dimming range from 20 to 100% of full brightness.
 5. All lighting projects shall include lighting point-by-point photometric calculations.

26.3.3 Electrical Systems Spare Capacity

The electrical system must be sized for the electrical load with additional minimum spare capacity as follows:

1. Main switchgear or switchboard: 20% spare capacity and 10% spare/space breakers.
2. Switchboards and distribution panels: 20% spare capacity and 10% spare/space breakers.
3. Panel boards for branch circuits: 20% spare capacity and 10% spare/space breakers. In case the Owner's program requirements include known future expansions, the spare capacity shall be additional to the future expansion needs.

26.4 Utility Coordination

Provide to FPL, upon initial contact with them, load calculations and the type of electrical system to be used, in accordance with section 26.5 (Distribution Systems), along with proposed location of service entrance.

Coordinate the location of service entrance and location of FPL transformers, switchgears, meters, right of way and any other equipment with the architect and civil engineer to avoid conflicts. Consider all FPL requirements, especially clearance and accessibility, when locating the entry of service. It is preferred to locate utility transformers located on UM property the preferred within a vault, which shall must comply with FPL requirements; including vehicular accessibility. No aerial conductors shall be used.

26.4.1 Short circuit calculations

The symmetrical fault current shall be calculated from the maximum available fault at the service entrance, according to utility and the specific building electrical system.

The short circuit withstands and/or interrupting capacity for any electrical equipment will be selected according the values of the short circuit calculations, above mentioned, at the location of the specific equipment.

26.4.2 Service entrance

1. Service entrance shall be by bus-duct from vaults or underground conduits. In the case of underground conduits, provide underground service entrance conduits of Rigid Metal Conduit (RMC) or Rigid Polyvinyl Chloride Conduit (PVC) Schedule 40 encased in concrete.
 - a. Concrete encasement shall be 2 inches on all sides with 1 inch minimum separation between power conduits. If conduits from different systems share the same concrete encasement, the minimum separation between power conduits and signal conduits shall be 3 inches.
 - b. The minimum depth of underground conduits beyond the building perimeter shall be 24" to the top of the concrete encasement.

26.5 Distribution System

Distribution Systems Voltage

1. Design the system voltage depending on specific project needs.

26.6 Electrical Rooms

Design Standards

1. Electrical Rooms are to be locked and accessible only to qualified persons. They shall not be accessible to faculty, students or for used for storage.

2. Electrical rooms shall be sized to accommodate all specified electrical equipment, with dimensions as outlined in the applicable Codes, but never smaller than 6'-0" x 8'-0". Room doors shall swing out.
3. Access to electrical room shall permit for the replacement of electrical equipment.
4. Provide 40% additional wall space for future equipment.
5. Electrical rooms shall be clear of columns, shear walls, stairways, duct shafts, elevators and other obstructions to allow for secondary distribution of electrical to assigned spaces.
6. Electrical rooms shall be centrally located, close to larger loads.
7. Satellite electric rooms (minimum of one per floor) shall be provided throughout the facility spaced at an interval of no greater than 300 feet.
8. Where electrical rooms occur in fully sprinklered buildings, they too shall be fully sprinklered.
9. In multistory buildings, the electrical rooms shall be stacked.
10. Floor mounted switchboards and motor control centers shall be placed on 4" high concrete curbs.
11. Switchboards, panel boards, contactors, and any other electrical equipment shall be located within electrical rooms.

26.7 Specific requirements (organized by CSI MasterFormat® 2012 Numbers & Titles)

26 05 13	Medium-Voltage Cables
26 05 19	Low Voltage Electrical Power Conductors and Cables
26 05 23	Control Voltage Electrical Power Cables
26 05 26	Grounding and Bonding for Electrical Systems
26 05 29	Hangers and Supports for Electrical Systems
26 05 33	Raceways and Boxes for Electrical Systems
26 05 36	Cable Trays for Electrical Systems
26 05 39	Underfloor Raceways for Electrical Systems
26 05 43	Underground Ducts and Raceways for Electrical Systems
26 05 44	Sleeves and Sleeve Seals for Electrical Raceways and Cabling
26 05 48	Vibration and Seismic Controls for Electrical Systems
26 05 53	Identification for Electrical Systems
26 05 73	Overcurrent Protective Device Coordination Study

26 09 13	Electrical Power Monitoring and Control
26 11 16	Secondary Unit Substations
26 12 00	Medium-Voltage Transformers
26 13 00	Medium-Voltage Switchgear
26 22 00	Low Voltage Transformers
26 23 00	Low Voltage Switchgear
26 23 13	Paralleling Low-Voltage Switchgear
26 24 13	Switchboards
26 24 16	Panel boards
26 24 16.16	Electronically Operated Circuit-Breaker Panel boards
26 24 19	Motor-Control Centers
26 25 00	Enclosed Bus Assemblies
26 26 00	Power Distribution Units
26 27 13	Electricity Metering
26 27 26	Wiring Devices
26 28 13	Fuses
26 28 16	Enclosed Switches and Circuit Breakers
26 29 13	Enclosed Controllers
26 29 23	Variable-Frequency Motor Controllers
26 31 00	Photovoltaic Energy Equipment
26 32 13	Engine Generators
26 33 23	Central Battery Equipment
26 33 53	Static Uninterruptible Power Supply
26 35 33	Power Factor Correction Equipment
26 36 00	Transfer Switches
26 41 13	Lightning Protection for Structures
26 42 00	Cathodic Protection
26 43 13	Surge Protection for Low-Voltage Electrical Power Circuits
26 51 00	Interior Lighting
26 55 61	Theatrical Lighting
26 56 00	Exterior Lighting
26 56 68	Exterior Athletic Lighting

26 05 13 Medium-Voltage Cables

This section might be used in future projects including medium-voltage cables (Cables, splices, terminations, connectors, and fault indicators for 2001 to 35,000V). Verify with UMBS.

26 05 19 Low-Voltage Electrical Power Conductors and Cables

Design Standards

1. All conductors shall be copper. Insulation shall be provided where specified.

2. Conductors are to be solid for No. 10 AWG and smaller; stranded for No. 8 AWG and larger.
3. Provide bushings at the end of sleeves to avoid damage to conductor's insulation.

26 05 23 Control Voltage Electrical Power Cables

Coordinate control voltage electrical power cables with divisions on Integrated Automation, Communications (Division 27) and Electronic Safety and Security (Division 28).

26 05 26 Grounding and Bonding for Electrical Systems

Design Standards

1. Equipment Grounding
 - a. Install insulated equipment grounding conductors with all feeders and branch circuits.
 - b. Provide grounding bars in all electrical rooms.

26 05 29 Hangers and Supports for Electrical Systems

Design Standards

1. Only the use of steel hot-dip galvanized after fabrication or aluminum support systems are permitted. When using hangers and supports of steel hot-dip galvanized, care shall be taken during the installation to insure the integrity of corrosion protection. Damaged corrosion protection shall be repaired during or after installation.
2. Design supports for multiple raceways with the ability to support combined weight of the systems and its contents.
3. Design equipment with the ability to support the combined operating weight of the equipment and connected systems and components.
4. Rated Strength: Adequate in tension, shear, and pullout force to resist maximum loads calculated or imposed for this Project, with a minimum structural safety factor of five times the applied force.
5. Steel slotted support systems shall be implemented with use of threaded rod hangers.

26 05 33 Raceways and Boxes for Electrical Systems

Design Standards

1. Raceway Application

- a. Outdoors: Apply raceway products as specified below unless otherwise indicated:
 - (1) Exposed Conduit: RMC (Galvanized rigid steel conduit) or IMC.
 - (2) Concealed Conduit, Aboveground: RMC (Galvanized rigid steel conduit) or IMC.
 - (3) Underground Conduit: RNC, Type EPC-40-PVC.
 - (4) Connection to Vibrating Equipment (Including Transformers and Hydraulic, Pneumatic, Electric Solenoid, or Motor-Driven Equipment): LFMC.
 - (5) Boxes and Enclosures, Aboveground: NEMA 250, Type 3R.

- b. Indoors: Apply raceway products as specified below unless otherwise indicated:
 - (1) Exposed, Not Subject to Physical Damage: EMT.
 - (2) Exposed, Not Subject to Severe Physical Damage: EMT.
 - (3) Exposed and Subject to Severe Physical Damage: RMC (galvanized rigid steel conduit). Raceway locations include, but are limited to, the following:
 - (a) Loading dock.
 - (b) Corridors used for traffic of mechanized carts, forklifts, and pallet-handling units.
 - (c) Mechanical rooms.
 - (d) Gymnasiums.
 - (4) Concealed in Ceilings and Interior Walls and Partitions: EMT.
 - (5) Connection to Vibrating Equipment (Including Transformers and Hydraulic, Pneumatic, Electric Solenoid, or Motor-Driven Equipment): FMC, except use LFMC in damp or wet locations.
 - (6) Damp or Wet Locations: RMC (Galvanized rigid steel conduit)
 - (7) Boxes and Enclosures: NEMA 250, Type 1, except use NEMA 250, Type 4 stainless steel in commercial kitchens and damp or wet locations.
 - (8) Underground Conduit: RNC, Type EPC-40-PVC.

- c. Minimum Raceway Size: 3/4-inch (21-mm) trade size.

- d. Raceway Fittings: Compatible with raceways and suitable for use and location.
 - (1) Rigid and Intermediate Steel Conduit: Use threaded rigid steel conduit fittings unless otherwise indicated. Comply with NEMA FB 2.10.
 - (2) PVC Externally Coated, Rigid Steel Conduits: Use only fittings listed for use with this type of conduit. Patch and seal all joints, nicks, and scrapes in PVC coating after installing conduits and fittings. Use sealant recommended by fitting manufacturer and apply in thickness and number of coats recommended by manufacturer.

 - (3) EMT: Use setscrew or compression, steel fittings. Comply with NEMA FB 2.10.
 - (4) Flexible Conduit: Use only fittings listed for use with flexible conduit. Comply with NEMA FB 2.20.

- e. Do not install aluminum conduits, boxes, or fittings where they may come in contact with concrete or earth.
 - f. All raceways in public spaces shall be concealed.
2. Boxes, Enclosures, and Cabinets
- a. Boxes, enclosures, and cabinets installed in wet locations shall be UL listed for use in wet locations.
 - b. Sheet Metal Outlet and Device Boxes: Outlets boxes shall be pressed - stamped, not welded, without concentric or eccentric knockouts.
 - c. Gang boxes are prohibited.

26 05 36 Cable Trays for Electrical Systems

Design Standards

- 1. Only steel hot-dip galvanized after fabrication or aluminum cable trays systems are permitted.
- 2. Use ground cable trays according to NFPA 70 unless additional grounding is specified. Cable trays with electrical power conductors shall be bonded together with splice plates UL listed for grounding purposes or with UL listed bonding jumpers.

Product Standards

- 1. Cable Trays and Accessories are to be provided as defined in NFPA 70 and marked for intended location, application, and grounding.

26 05 39 Underfloor Raceways for Electrical Systems

This section shall be used in projects which include underfloor raceways including single-channel and multichannel flat-top, flush, three-cell, cellular metal, and trench types. This section shall also be used in projects specifying electrification products for structural cellular metal and concrete floor decks, and junction boxes and service fittings for the above products.

26 05 43 Underground Ducts and Raceways for Electrical Systems

Design Standards

- 1. Layout and installation of ducts, manholes, hand-holes, and boxes shall be coordinated with final arrangement of other utilities, site grading, and surface features as determined in the field. Verify field measurements, routing and termination locations of duct bank prior to excavation for rough-in. Coordinate duct bank installation with underground work, site work and other site improvement work specified in other divisions.

2. Actual routing of duct bank shall be included on Project record documents, and submitted to UM.
3. Duct Slope: Pitch ducts a minimum slope of 1:300 down toward manholes and hand-holes and away from buildings and equipment. Slope ducts from a high point in runs between two manholes to drain in both directions.
4. Earthwork
 - a. Excavation and Backfill: Comply with Section "Earth Moving", but do not use heavy-duty, hydraulic-operated, compaction equipment.
 - b. Prepare excavation, base material installation, and compaction necessary for the specific duct bank arrangement.
 - c. Verify that excavation, base material installation, and compaction is completed.
 - d. Backfill trenches as specified in Section "Earth Moving".
5. Concrete: Comply with ASTM C 858.

Product Standards

1. Conduit: RNC: Type EPC-40-PVC with matching fittings by same manufacturer as the conduit.
2. Duct Accessories
 - a. Duct Separators: Factory-fabricated rigid PVC interlocking spacers, sized for type and sizes of ducts with which used, and selected to provide minimum duct spacing indicated while supporting ducts during concreting or backfilling.
 - b. Warning Tape: Underground-line warning tape detectable and pigmented polyolefin, bright color, continuous printed with utility inscription, compounded for direct burial.
3. Concrete Warning Planks:
 - a. Nominal 12 by 24 by 3 inches (300 by 600 by 76 mm) in size, manufactured from 6000-psi (41-MPa) concrete.
 - b. Color: Red dye added to concrete during batching.
 - c. Mark each plank with "ELECTRIC" in 2-inch- (50-mm-) high, 3/8-inch- (10-mm-) deep letters.

26 05 44 Sleeves and Sleeve Seals for Electrical Raceways and Cabling

Design Standards

1. This Section shall specify penetration methods into and through unrated walls, ceilings, and floors, as well as the sealing of conduit penetrations against water. For rated walls, ceilings, and floors see Section 078413 "Penetration Fire stopping."
2. Sleeve installation must be closely coordinated with concrete and masonry work.

3. Sleeves are required in these conditions:
 - a. To prevent movement of air through a raceway from a warmer to a colder section (as in a raceway used to enclose lighting and refrigeration branch-circuit conductors for a walk-in cooler), which might lead to condensation within the raceway. This condition can be prevented by sealing the raceway with a suitable pliable compound before it enters the colder section.
 - b. In busway runs that have sections located in both the interior and exterior of buildings, these runs are required to have a vapor seal at the building wall to prevent interchange of air between interior and exterior sections.
4. Fire stopping is required for conduits, tubing, cables, and cable trays penetrating fire-resistant-rated walls, horizontal assemblies, or smoke barriers. See Section "Penetration Fire stopping" for fire stopping systems and installation requirements.
5. Sleeve-seal systems are required.

26 05 48 Vibration and Seismic Controls for Electrical Systems

This Section specifies seismic criteria, seismic restraints and supports, and vibration isolation devices. Seismic design shall conform to the current Florida Building Code and ASCE/SEI 7 (Minimum Design Loads for Buildings and Other Structures).

This Section does not specify basic hangers, supports, anchors, and concrete base construction required for electrical work. See Section 260529 "Hangers and Supports for Electrical Systems" for these items.

26 05 53 Identification for Electrical Systems

Design Standards

1. All electrical equipment shall be provided with permanent identification nameplates as follows:
 - a. The following identification markings shall be provided on each circuit breaker, disconnect switch, contactor, motor starter, etc.
 - (1) Equipment designation as shown on the drawings.
 - (2) Voltage and amperage.
 - (3) Load identification in sufficient detail to allow specific circuit to be distinguished unequivocally.
 - b. The following identification markings shall be provided on each transformer:
 - (1) Transformer designation as shown on the drawings.
 - (2) Voltage (primary/secondary).
 - (3) Transformer capacity.
 - (4) Name of panels supplied by the secondary of the transformer.

- c. The following alkyd paint, stenciled inscription markings shall be provided on the outside face and inside face of each feeder splice box, feeder junction box, and feeder pull box cover plate:
 - (1) Designation of source.
 - (2) Designation of item of equipment served.
 - (3) Voltage.
- d. The following identification markings shall be provided on each switchgear, paralleling switchgear, switchboards, and panel boards:
 - (1) Designation as shown on the drawings.
 - (2) Source of supply designation.
 - (3) Voltage (primary/secondary).
- e. Device plates for switches, toggle switch type manual starters, pilot lights, and other electrical items, whose function is not readily apparent, shall be provided with engraved inscriptions or plastic laminate nameplates describing the equipment controlled or indicated.
- f. Each wire and cable shall be labeled at terminals and at all accessible points in equipment, panel boards, manholes, hand-holes, and pull boxes. Labels shall be self-sticking wire markers.
- g. Conduits shall be tagged at the ends and in intermediate boxes, chambers, manholes, hand-holes, and other enclosures in accordance with the same inscriptions as shown on the drawings.
- h. Phase identification letters, in readily visible locations, shall be stamped into the main bus bars of switchgear, switchboards and panelboards.
- i. Provide on the exterior door of each vault or other room or enclosure containing equipment operating over 600 volts, a vitreous enameled metal sign, red or white, reading "Warning - High Voltage - Keep Out."
- j. Provide in each switchboard room, electrical closet, or other space containing electrical equipment, a vitreous enameled metal sign, red on white, reading "Electrical Equipment Room - No Storage Permitted". Signs shall be mounted at clearly visible locations within the rooms or on the inside of doors where wall space within the room is not available.
- k. Provide in all Electrical Rooms a framed, laminated or in Plexiglas cover, ONE LINE or RISER DIAGRAM drawings including the equipment located in the specific electrical room highlighted in yellow, complete with the feeder schedules. The print shall be made from the latest "Record" drawing at 100%. The preferred location of the drawings is the back of the door to avoid using usable space for future electrical equipment.
- l. Provide color-coded covers for each box and panel, for identification, as follows:
 - (1) Normal Power System: Gray (the use of the natural steel color is for boxes)

- (2) Emergency (essential for safety to human life) Power System: Pink
- (3) Standby Power System: Black
- (4) Uninterruptible Power Supply (UPS) system: Orange

- m. The following colors are reserved for other systems:
 - (1) Fire alarm: Red
 - (2) Security alarm: Blue
 - (3) Sound: Yellow
 - (4) Telephone/IT: Green
 - (5) TV: Brown
 - (6) Controls: Purple
 - (7) Clock: Beige or off-white

- n. Color-coded conductors:
 - (1) Wiring for 120/208 Volt System shall be color-coded as follows:
 - (a) Phase "A" - Black
 - (b) Phase "B" - Red
 - (c) Phase "C" - Blue
 - (d) Neutral - White
 - (e) Ground - Green

 - (2) Wiring for 277/480 Volt System shall be color-coded as follows:
 - (a) Phase "A" - Brown
 - (b) Phase "B" - Orange
 - (c) Phase "C" - Yellow
 - (d) Neutral - Natural Gray
 - (e) Ground - Green

- p. Colors on conductor 6 AWG and smaller shall be integral part of insulation. On conductor 4 AWG and larger conductors, use either color-coded tape or apply two coats of paint (see color-coded information above) at all terminals and connection points.

- 2. Equipment Identification Labels
 - a. Engraved, Laminated Acrylic or Melamine Label: Punched or drilled for non-corroding type screw mounting - white letters on a dark-gray background. Minimum letter height shall be 3/8 inch.
 - b. Stenciled Legend: Use nonfading, waterproof, black alkyd paint. Minimum letter height shall be 1 inch.

- 3. Power and Control Cable Identification Materials
 - a. Self-Adhesive, Self-Laminating Polyester Labels: Preprinted, 3-mil thick flexible label with acrylic pressure-sensitive adhesive to provide a clear, weather- and chemical-resistant, self-laminating, protective shield over the legend. Labels sized to fit the cable diameter such that the clear shield overlaps the entire printed legend.

- 4. Metal Tags
 - a. Brass or aluminum, 2 by 2 by 0.05 inch, with stamped legend, punched for use with self-locking cable tie fastener.

5. Color-Coded Conductor Tape
 - a. Colored, self-adhesive vinyl tape, not less than 3 mils thick by 1 to 2 inches wide.

26 05 73 Overcurrent Protective Device Coordination Study

Design Standards

1. The design engineer shall submit a preliminary Overcurrent Protective Co-ordination study along with the 100% Construction Documents.
2. A final coordination and analysis study shall be submitted once the provider for the over current protective devices has been selected. The final report, showing coordination, shall be sent to UM,
3. The coordination study will determine the selection and settings for the protective devices which will isolate short circuit or overloads to only the affected area. The coordination study shall include the closest upstream utility protective device down to the panel board main, branch, or feeder circuit breakers. The coordination study shall consider operation during normal conditions, alternate operation, and during emergency power conditions.

26 09 13 Electrical Power Monitoring and Control

Design Standards

1. Provide an electronic system for local and remote monitoring, metering, and control of electrical power distribution systems. This system shall be controllable and programmable by existing campus BMS using BACnet protocol.
2. At point of electrical service entrance provide metering connected to BMS.
3. Provide metering according Owner's program requirements and the project's programmed sustainability rating (LEED rating).
4. Provide independent metering for new parking lots and exterior lighting.

Performance Standards

1. Systems shall include the following:
 - a. Calculate and Record the Following:
 - (1) Load factor.
 - (2) Peak demand periods.
 - b. Power Quality Monitoring: Identify power system anomalies and measure, display, and record trends and alarms of the following power quality parameters:

- (1) Voltage regulation and imbalance.
 - (2) Continuous three-phase rms voltage.
 - (3) Periodic max. /min. /avg. voltage samples.
 - (4) Harmonics.
 - (5) Voltage excursions.
2. Metered Data: Display metered values in real time.
3. Remote Control:
 - a. Display circuit-breaker status and allow breaker control.
 - b. User defined with load-shedding automatically initiated and executed schemes responding to programmed time schedules, set points of metered demands, utility contracted load shedding, or combinations of these.
4. Waveform Data: Display and record waveforms on demand or automatically on an alarm or programmed event. Include the graphic displays of the following, based on user-specified criteria:
 - a. Phase voltages, phase currents, and residual current.
 - b. Waveforms ranging in length from 2 cycles to 5 minutes.
 - c. Disturbance and steady-state waveforms up to 512 points per cycle.
 - d. Calculated waveform, based on recorded data, on a minimum of four cycles of data of the following:
 - (1) THD (total harmonic distortion).
 - (2) rms (root mean square) magnitudes.
 - (3) Peak values.
 - (4) Crest factors.
 - (5) Magnitude of individual harmonics.
5. Data Sharing: Allow export of recorded displays and tabular data to third-party applications software.
6. Activity Billing Software:
 - a. Automatically compute and prepare activity demand and energy-use statements based on metering of energy use and peak demand integrated over user-defined interval.
 - b. Intervals shall be same as used by electric utilities, including current vendor.
 - c. Import metered data from saved records that were generated by metering and monitoring software.
 - d. Maintain separate directory for each activity's historical billing information.
 - e. Prepare summary reports in user-defined formats and time intervals.
7. Reporting: User commands initiate the reporting of a list of current alarm, supervisory, and trouble conditions in system or a log of past events.
 - a. Print a record of user-defined alarm, supervisory, and trouble events on workstation printer.
 - b. Sort and report by device name and by function.
 - c. Report type of signal (alarm, supervisory, or trouble), description, date, and time of occurrence.
 - d. Differentiate alarm signals from other indications.

- e. When system is reset, report reset event with same information concerning device, location, date, and time.

26 11 16 Secondary Unit Substations

In projects where secondary unit substations are used, this section shall be reviewed by University of Miami Building Standards Committee. (UMBSC)

26 12 00 Medium-Voltage Transformers

This section shall be used in projects requiring medium-voltage cables (Transformers 2.4 to 35 kV).

26 13 00 Medium-Voltage Switchgear

This section shall be used in projects requiring medium-voltage cables (Metal-enclosed interrupter and metal-clad CB type switchgear up to 34 kV class).

26 22 00 Low-Voltage Transformers

Product Standards

1. Provide one of the following (subject to compliance with requirements):
 - a. Eaton Electrical Inc.; Cutler-Hammer Business Unit.
 - b. General Electric Company; GE Consumer & Industrial - Electrical Distribution.
 - c. Siemens Energy & Automation, Inc.
 - d. Square D; a brand of Schneider Electric.
2. Provide K-1 transformers where expected non-linear load is < 25%.
3. Provide K-4 transformer where expected non-linear load is > 25% but < 75%.
4. Provide K-13 transformer where expected non-linear load is > 75%.

26 23 00 Low-Voltage Switchgear

Design Standards

1. All switchgears, whether new or existing to be modified during construction, shall be provided with a typewritten directory describing the loads connected to each circuit breaker. .
2. Phase-and-Neutral-Bus Material: Hard-drawn copper of 98 percent minimum conductivity, with copper feeder circuit-breaker line connections. Use copper for connecting circuit-breaker line to copper bus.

3. Contact Surfaces of Buses: Silver plated.
4. Feeder Circuit-Breaker Load Terminals: Silver-plated copper bus extensions equipped with pressure connectors for outgoing circuit conductors.
5. Ground Bus: Hard-drawn copper of 98 percent minimum conductivity, with pressure connector for feeder and branch-circuit ground conductors, minimum size 1/4 inch by 2 inches (6 by 50 mm).
6. Supports and Bracing for Buses: Adequate strength for indicated short-circuit currents.
7. Neutral bus equipped with pressure-connector terminations for outgoing circuit neutral conductors. Neutral-bus extensions for busway feeders are braced.
8. Multifunction Digital-Metering Monitor: UL-listed or recognized, microprocessor-based unit suitable for three or four wire systems and with the following features:
 - a. Inputs from sensors or 5-A current-transformer secondaries, and potential terminals rated to 600 V.
 - b. Switch-selectable digital display of the following:
 - (1) Phase Currents, Each Phase: Plus or minus 1 percent.
 - (2) Phase-to-Phase Voltages, Three Phase: Plus or minus 1 percent.
 - (3) Phase-to-Neutral Voltages, Three Phase: Plus or minus 1 percent.
 - (4) Three-Phase Real Power: Plus or minus 2 percent.
 - (5) Three-Phase Reactive Power: Plus or minus 2 percent.
 - (6) Power Factor: Plus or minus 2 percent.
 - (7) Frequency: Plus or minus 0.5 percent.
 - (8) Integrated Demand, with Demand Interval Selectable from 5 to 60 Minutes: Plus or minus 2 percent.
 - (9) Accumulated energy, in megawatt hours (joules), plus or minus 2 percent; stored values unaffected by power outages for up to 72 hours.
9. Mounting: Display and control unit flush or semi flush mounted in instrument compartment door.
10. Short-Circuit Current Rating: Fully rated to interrupt symmetrical short-circuit current available at terminals. All Molded-Case Circuit Breaker (MCCB) shall be specified with interrupting capacity to meet available fault currents.
11. Communication Capability: A communication module with functions and features compatible with existing UM power monitoring and control system in the BMS shall be provided.

Product Standards

1. Subject to compliance with requirements, provide product by one of the following:
 - a. Eaton Electrical Inc.; Cutler-Hammer Business Unit.
 - b. General Electric Company; GE Consumer & Industrial - Electrical Distribution.
 - c. Siemens Energy & Automation, Inc.
 - d. Square D; a brand of Schneider Electric.

26 23 13 Paralleling Low-Voltage Switchgear

This section might be used in future projects, including multiple generator operation. Verify with UMBSA.

26 24 13 Switchboards**Design Standards**

1. All switchboards, whether new or existing to be modified during construction, shall be provided with a typewritten directory describing the load connected to each circuit breaker.
2. Phase- and Neutral-Bus Material: Hard-drawn copper of 98 percent minimum conductivity, with copper feeder circuit-breaker line connections. Use copper for connecting circuit-breaker line to copper bus.
3. Contact Surfaces of Buses: Silver plated.
4. Feeder Circuit-Breaker Load Terminals: Silver-plated copper bus extensions equipped with pressure connectors for outgoing circuit conductors.
5. Ground Bus: Hard-drawn copper of 98 percent minimum conductivity, with pressure connector for feeder and branch-circuit ground conductors, minimum size 1/4 inch by 2 inches (6 mm by 50 mm).
6. Supports and Bracing for Buses: Adequate strength for indicated short-circuit currents.
7. Neutral bus equipped with pressure-connector terminations for outgoing circuit neutral conductors. Neutral-bus extensions for busway feeders shall be braced.
8. Multifunction Digital-Metering Monitor: UL-listed or recognized, microprocessor-based unit suitable for three or four wire systems, with the following features:
 - a. Inputs from sensors or 5-A current-transformer secondaries, and potential terminals rated to 600 V.
 - b. Switch-selectable digital display of the following:
 - (1) Phase Currents, Each Phase: Plus or minus 1 percent.
 - (2) Phase-to-Phase Voltages, Three Phase: Plus or minus 1 percent.
 - (3) Phase-to-Neutral Voltages, Three Phase: Plus or minus 1 percent.
 - (4) Three-Phase Real Power: Plus or minus 2 percent.
 - (5) Three-Phase Reactive Power: Plus or minus 2 percent.
 - (6) Power Factor: Plus or minus 2 percent.
 - (7) Frequency: Plus or minus 0.5 percent.
 - (8) Integrated Demand, with Demand Interval Selectable from 5 to 60 Minutes: Plus or minus 2 percent.

- (9) Accumulated energy, in megawatt hours (joules), plus or minus 2 percent; stored values unaffected by power outages for up to 72 hours.
9. Mounting: Display and control unit flush or semi flush mounted in instrument compartment door.
10. Short-Circuit Current Rating: Fully rated to interrupt symmetrical short-circuit current available at terminals. All Molded-Case Circuit Breaker (MCCB) shall be specified with interruption capacity to meet available fault currents.
11. Communication Capability: A communication module with functions and features compatible with existing UM power monitoring and control system in the BMS shall be provided.

Product Standards

1. Subject to compliance with requirements, provide product by one of the following:
 - a. Eaton Electrical Inc.; Cutler-Hammer Business Unit.
 - b. General Electric Company; GE Consumer & Industrial - Electrical Distribution.
 - c. Siemens Energy & Automation, Inc.
 - d. Square D; a brand of Schneider Electric.

26 24 16 Panel boards

Design Standards

1. All panel boards, whether new or existing modified during construction, shall be provided with a typewritten directory describing the load connected to each circuit breaker.
2. Phase-and-Neutral-Bus Material: Hard-drawn copper of 98 percent minimum conductivity, with copper feeder circuit-breaker line connections. Use copper for connecting circuit-breaker line to copper bus.
3. Contact Surfaces of Buses: Silver plated.
4. Feeder Circuit-Breaker Load Terminals: Silver-plated copper bus extensions equipped with pressure connectors for outgoing circuit conductors.
5. Ground Bus: Hard-drawn copper of 98 percent minimum conductivity.
6. Supports and Bracing for Buses: Adequate strength for indicated short-circuit currents.
6. Short-Circuit Current Rating: Fully rated to interrupt symmetrical short-circuit current available at terminals. All Molded-Case Circuit Breaker (MCCB) shall be specified with interrupting capacity to meet available fault currents.

Product Standards

1. Subject to compliance with requirements, provide product by one of the following:
 - a. Eaton Electrical Inc.; Cutler-Hammer Business Unit.
 - b. General Electric Company; GE Consumer & Industrial - Electrical Distribution.
 - c. Siemens Energy & Automation, Inc.
 - d. Square D; a brand of Schneider Electric.

26 24 16.16 Electronically Operated Circuit-Breaker Panel boards

This section might be used in future projects. Verify with UMBSC.

26 24 19 Motor-Control Centers**Design Standards**

1. All motor-control centers, whether new or existing to be modified during construction, shall be provided with engraved plastic labels, describing the load connected to each circuit breaker.
2. All motor controllers shall have an integral transformer with 120 volt secondary for control circuits.

Product Standards

1. Subject to compliance with requirements, provide product by one of the following:
 - a. Eaton Electrical Inc.; Cutler-Hammer Business Unit.
 - b. General Electric Company; GE Consumer & Industrial - Electrical Distribution.
 - c. Siemens Energy & Automation, Inc.
 - d. Square D; a brand of Schneider Electric.

26 25 00 Enclosed Bus Assemblies**Design Standards**

1. Enclosed bus assemblies shall be used when they provide savings for the specific project.
2. Obtain feeder-bus assemblies, plug-in bus assemblies and bus plug-in devices from a single manufacturer.
3. Enclosed bus assemblies shall have a maximum temperature rise of 55 deg. C above 40 deg. C ambient maximum for continuous rated current.

26 26 00 Power Distribution Units**Design Standards**

1. All power distribution units, whether new or existing to be modified during construction, shall be provided with a typewritten directory describing the load connected to each circuit breaker.

26 27 13 Electricity Metering**Design Standards**

1. Service: Coordinate types of meter enclosures to be used with FPL.
2. Owner metering:
 - a. Include metering for all new construction, and renovations impacting more than 50% of floor/bldg. Meter locations require approval by University of Miami Building Standards Committee. (UMBSC).
 - b. Kilowatt-hour Meter shall be electronic with voltage and phase configuration designed according metered circuit.
 - c. Display: LCD with characters not less than 0.25 inch (6 mm) high, indicating accumulative kilowatt-hours and current kilowatt load. Retain accumulated kilowatt-hour in a nonvolatile memory, until reset.
 - d. Activity Software: Automatically import energy-usage records to automatically compute and prepare activity demand and energy-use statements based on metering of energy use and peak demand. Maintain separate directory for each location's historical billing information. Prepare summary reports in user-defined formats and time intervals.
 - e. Meters shall connect through BACnet/MSTP
 - f. Meters shall be Square D or Veris Industries. Alternate manufacturers require approval by University of Miami Building Standards Committee. (UMBSC)

26 27 26 Wiring Devices**Design Standards**

1. Provide duplex receptacles at intervals not to exceed 50 feet in all corridors, for cleaning equipment.
2. Provide a weather proof, GFI receptacle within 25 feet of each trash compactor locations.

3. Do not locate outlets back to back in common walls.
4. A maximum of three adjacent switches may be ganged under a common faceplate. Should additional switches be required, provide in multiples of two and/or three.
5. Provide engraved inscriptions or plastic laminate nameplates on device plates for local toggle switches, toggle switch type manual starters, pilot lights, and other electrical items, where the function is not readily apparent, with a description of the equipment controlled or indicated.
6. Device Color:
 - a. Wiring Devices Connected to Normal Power System: Ivory.
 - b. Wiring Devices Connected to Emergency (essential for safety to human life) Power System: Red.
 - c. Wiring Devices Connected to Standby Power System: Gray.
 - d. Wiring Devices Connected to Uninterruptible Power Supply (UPS) system: Orange.
 - e. TVSS Devices: Blue.
 - f. Isolated-Ground Receptacles: Brown, with orange triangle on face
 - g. Wall Plate Color: Match device color.
7. Duplex receptacles shall be rated at 20A, 125V AC.
8. Plates shall be smooth, high-impact thermoplastic in all areas. Oversized plates are preferred.
9. Plate design shall be smooth and without ornamentation.
10. All wiring devices shall be specification grade.

Product Standards

1. Provide product by one of the following, (subject to compliance with requirements):
 - a. Cooper.
 - b. Hubbell.
 - c. Leviton.
 - d. Pass & Seymour.

Performance Standards

1. The engineer's specifications shall require the submittal and approval of shop drawings prior to purchase. The shop drawings shall include illustrations, dimensions and specifications for all devices. The specifications shall also require that samples be submitted if requested.
2. The installation of all wall outlets must be leveled, with faceplates flat and tight to the wall. All devices and plates must be thoroughly cleaned of paint and dirt prior to final acceptance of the project.

26 28 13 Fuses**Design Standards**

1. Install labels as specified in Section 260553 - "Identification for Electrical Systems" and indicating fuse replacement information on inside door of each fused switch and adjacent to each fuse block and holder.

26 28 16 Enclosed Switches and Circuit Breakers**Design Standards**

1. Provide heavy duty fusible switches and non-fusible switches.

Product Standards

1. Subject to compliance with requirements, provide product by one of the following:
 - a. Eaton Electrical Inc.; Cutler-Hammer Business Unit.
 - b. General Electric Company; GE Consumer & Industrial - Electrical Distribution.
 - c. Siemens Energy & Automation, Inc.
 - d. Square D; a brand of Schneider Electric.

26 29 13 Enclosed Controllers**Design Standards**

1. Provide motor controllers as required. Coordinate with other disciplines to confirm all necessary motor controllers are included in the design.
2. Solid state overload relay and phase loss protection will be provided with all magnetic motor starters.

26 29 23 Variable-Frequency Motor Controllers

1. Provide variable-frequency motor controllers as required. Coordinate with other disciplines to confirm all necessary variable-frequency motor controllers are included in the design.
2. Provide variable-frequency motor controllers compatible with the specified loads. Coordinate features of motors, load characteristics, installed units, and accessory devices to be compatible with the following:
 - a. Torque, speed, and horsepower requirements of the load.
 - b. Ratings and characteristics of supply circuit and required control sequence.
 - c. Ambient and environmental conditions of installation location.

3. Variable-frequency motor controllers' minimum efficiency shall be 97 percent at 60 Hz, full load.
4. Provide the following self-protection and reliability features:
 - a. Input transient protection by means of surge suppressors to provide three-phase protection against damage from supply voltage surges 10 percent or more above nominal line voltage.
 - b. Loss of Input Signal Protection: Selected response strategy, including speed default to a percent of the most recent speed, a preset speed, or stop; with alarm.
 - c. Under and overvoltage trips.
 - d. Inverter overcurrent trips.
 - e. Variable-frequency motor controller and Motor Overload/Over-temperature Protection: Microprocessor-based thermal protection system for monitoring variable-frequency motor controllers and motor thermal characteristics, and for providing variable-frequency motor controller over-temperature and motor overload alarm and trip; settings selectable via the keypad.
 - f. Critical frequency rejection, with three selectable, adjustable dead bands.
 - g. Instantaneous line-to-line and line-to-ground overcurrent trips.
 - h. Loss-of-phase protection.
 - i. Reverse-phase protection.
 - j. Short-circuit protection.
 - k. Motor over-temperature fault.

26 31 00 Photovoltaic Energy Equipment

Design Standards

1. Provide photovoltaic panels approved for use in Miami-Dade; in accordance with UM's program requirements.

26 32 13 Engine Generators

Design Standards

1. All projects shall include a connection for a portable generator, including all necessary equipment for connecting a portable generator (for example, Manual Transfer Equipment, Connection Point, and so on). The equipment for connecting the portable generator shall be designed to feed the following loads:
 - a. Security System
 - b. BMS
 - c. Elevators according UM's program requirements.
 - d. Computers and data processing equipment – U.P.S. according UM's program requirements.
 - e. Research Labs, selected circuits according UM's program requirements.
 - f. Food storage Refrigeration according UM's program requirements.

- g. Lighting (non-emergency) for selected offices/areas according UM's program requirements.
 - h. HVAC according UM's program requirements.
2. Connection points shall be coordinated to provide access to the portable generator and refueling service.
3. Portable Generators shall be monitored and controllable by existing campus BMS using BACnet protocol.
4. When an emergency generator is required by any code or regulation, the generator shall be sized to run all emergency (essential for safety to human life) loads. All legally required standby systems and the optional standby loads are as follows:
 - a. Security System
 - b. BMS
 - c. Elevators according UM's program requirements.
 - d. Computers and data processing equipment – U.P.S. according UM's program requirements.
 - e. Research Labs, selected circuits according UM's program requirements.
 - f. Food storage Refrigeration according UM's program requirements.
 - g. Lighting (non-emergency) for selected offices/areas according UM's program requirements.
 - h. HVAC according UM's program requirements.
 - i. Size generators to serve approximately 110% of design load.
 - j. Provide fuel storage according UM's program requirements in addition to that necessary for the generator working at full load per codes and regulations required loads.
5. Generators shall be monitored and controlled by existing campus BMS using BACnet protocol.
6. Generator/UPS Compatibility: When the project requires UPS's, coordinate compatibility with the specified UPS that will be used.
7. System shall be package of new and current equipment consisting of:
 - a. A diesel engine driven electric generating set to provide standby power.
 - b. An engine start-stop control system.
 - c. An automatic load transfer control to provide automatic starting and stopping of the engine and switching of the load.
8. Obtain package generator sets and auxiliary components from a single manufacturer, and a single source. Informational submittals shall include a certified summary of prototype-unit test report.
9. Prototype Testing: Factory test engine-generator sets using same engine model, constructed of identical or equivalent components and equipped with identical or equivalent accessories. Tests: Comply with NFPA 110, Level 1 Energy Converters and with IEEE 115.

10. Project-Specific Equipment Tests: Before shipment, factory test engine-generator sets and other system components and accessories manufactured specified for this Project. Perform tests at rated load and power factors, including the following tests:
 - a. Test components and accessories furnished with installed units, but which are not identical to those on tested prototype, to demonstrate compatibility and reliability.
 - b. Full load run.
 - c. Maximum power.
 - d. Voltage regulation.
 - e. Transient and steady-state governing.
 - f. Single-step load pickup.
 - g. Safety shutdown.
 - h. Provide 14 days' advance notice of tests to allow for observation by UM's representative.
 - i. Submit factory test results within 10 days of completion.
11. Installer Qualifications: The manufacturer's authorized representative shall be trained and approved for installation of units specified for this Project; and is located not more than four hours' normal travel time from Installer's place of business to Project site.
12. Source Limitations: Obtain packaged generator sets and auxiliary components from a single manufacturer and a single source.
13. Electrical Components, Devices, and Accessories: UL listed and labeled as defined in NFPA 70, Article 100, by a testing agency acceptable to authorities having jurisdiction, and marked for intended use.
14. Comply with ASME B15.1.
15. Comply with NFPA 37.
16. Comply with NFPA 70.
17. Comply with NFPA 110 requirements for Level 1 and 2 emergency power supply system.
18. Comply with UL 2200.
19. Engine Exhaust Emissions: Comply with applicable state and local government requirements.
20. Noise Emission: Comply with applicable state and local government requirements. Project criteria for maximum noise level at adjacent property boundaries due to sound emitted by generator set including engine, engine exhaust, engine cooling-air intake and discharge, and other components of installation shall not be more than 85 dBA.

Product Standards

1. Provide product by one of the following, subject to compliance with specifications:
 - a. Caterpillar; CAT Power Generation.
 - b. Generac Power Systems, Inc.
 - c. Kohler Co.; Generator Division.
 - d. Cummins Power Generation.
 - e. MTU On Site Energy.

2. Tests and Inspections
 - a. Perform tests recommended by manufacturer and each electrical test and visual and mechanical inspection for "AC Generators and for Emergency Systems" specified in NETA Acceptance Testing Specification. Certify compliance with test parameters.
 - b. NFPA 110 Acceptance Tests: Perform tests required by NFPA 110 that are additional to those specified here including, but not limited to, single-step full-load pickup test.
 - c. Battery Tests: Equalize charging of battery cells according to manufacturer's written instructions. Record individual cell voltages.
 - (1) Measure charging voltage and voltages between available battery terminals for full-charging and float-charging conditions. Check electrolyte level and specific gravity under both conditions.
 - (2) Test for contact integrity of all connectors. Perform an integrity load test and a capacity load test for the battery.
 - (3) Verify acceptance of charge for each element of the battery after discharge.
 - (4) Verify that measurements are within manufacturer's specifications.
 - d. Battery-Charger Tests: Verify specified rates of charge for both equalizing and float-charging conditions.
 - e. System Integrity Tests: Methodically verify proper installation, connection, and integrity of each element of engine-generator system before and during system operation. Check for air, exhaust, and fluid leaks.
 - f. Exhaust-System Back-Pressure Test: Use a manometer with a scale exceeding 40-inch wg (120 kPa). Connect to exhaust line close to engine exhaust manifold. Verify that back pressure at full-rated load is within manufacturer's written allowable limits for the engine.
 - g. Voltage and Frequency Transient Stability Tests: Use recording oscilloscope to measure voltage and frequency transients for 50 and 100 percent step-load increases and decreases, and verify that performance is as specified.
 - h. Harmonic-Content Tests: Measure harmonic content of output voltage below 25 percent and at 100 percent of rated linear load. Verify that harmonic content is within specified limits.
 - i. Noise Level Tests: Measure A-weighted level of noise emanating from generator-set installation, including engine exhaust and cooling-air intake and discharge, at four locations, and compare measured levels with required values.
 - j. Coordinate tests with tests for transfer switches and run them concurrently.

- k. Test instruments shall have been calibrated within the last 12 months, traceable to standards of NIST, and adequate for making positive observation of test results. Make calibration records available for examination on request.
- l. Leak Test: After installation, charge system and test for leaks. Repair leaks and retest until no leaks exist.
- m. Operational Test: After electrical circuitry has been energized, start units to confirm proper motor rotation and unit operation.
- n. Test and adjust controls and safeties. Replace damaged and malfunctioning controls and equipment.
- o. Remove and replace malfunctioning units and retest as specified above.
- p. Retest: Correct deficiencies identified by tests and observations and retest until specified requirements are met.
- q. Report results of tests and inspections in writing. Record adjustable relay settings and measured insulation resistances, time delays, and other values and observations. Attach a label or tag to each tested component indicating satisfactory completion of tests.
- r. Infrared Scanning: After Substantial Completion, but not more than 60 days after Final Acceptance, perform an infrared scan of each power wiring termination and each bus connection. Remove all access panels so terminations and are accessible to portable scanner.
- s. Follow-up Infrared Scanning: Perform an additional follow-up infrared scan 11 months after date of Substantial Completion.
- t. Instrument: Use an infrared scanning device designed to measure temperature or to detect significant deviations from normal values. Provide calibration record for device.
- u. Record of Infrared Scanning: Prepare a certified report that identifies terminations and connections checked and that describes scanning results. Include notation of deficiencies detected, remedial action taken and observations after remedial action.

Performance Standards

1. The electrical contractor shall be responsible to coordinate all trades to ensure the proper functioning of the entire system including but not limited to fuel supply, exhaust equipment and air transfer system. This coordination shall include furnishing all required information to other contractors with regard to fuel, exhaust and cooling system dimensions, pipe and duct sizes, etc. Electrical contractor shall furnish a dimensioned plan layout indicating all generator dimensions, roughing dimensions, piping layout, duct layout, tank locations and elevations and all required electrical wiring and interconnections. Provide a note to this effect in the project manual.
2. Provide operating and maintenance manuals complete with replacement parts data for standby emergency generator system.
3. Standby Emergency Generator shall be installed in accordance with the manufacturer's recommendations and in compliance with the requirements of NFPA and all pertaining codes.

4. Provide a 6 inch high concrete pad under the generator set.
5. Furnish owner with manufacturer's certification and warranty assuring each item of equipment is complete and in good condition, free from damage, properly installed, connected, adjusted and tested as to full power rating, stability and voltage and frequency regulation.
6. The electric generator set shall receive the manufacturer's standard testing. Prior to acceptance of the installation, the equipment shall be tested to show it will start automatically, subjected to full load test; or that load which is available at the job-site, shut down and reset. Prior to acceptance, the contractor at his expense shall correct any defects that become evident during this test.
7. On completion of the installation, an independent commissioning agent shall perform the initial start-up. At the time of start-up, operating instructions and maintenance procedures shall be thoroughly explained to operating personnel. Two copies of operating and maintenance instruction books shall be supplied for the electric set and such auxiliary equipment as may require it.
8. Warranty: Standby electric generating set shall be provided by manufacturer and shall be warranted for a period of five years from date of acceptance. Copy of written warranty shall be attached to shop drawing submittal.

26 33 23 Central Battery Equipment

This section might be used in future projects, including central battery equipment for supplying power to emergency and standby lighting and power circuits. Verify with UMBSC.

26 33 53 Static Uninterruptible Power Supply

Design Standards

1. Generator/UPS Compatibility: If the project includes powering the UPSs from a generator, coordinate compatibility with the specific generator that will be used.
2. Automatic operation includes the following:
 - a. Normal Conditions: Load is supplied with power flowing from the normal power input terminals, through the rectifier-charger and inverter, with the battery connected in parallel with the rectifier-charger output.
 - b. Abnormal Supply Conditions: If normal supply deviates from specified and adjustable voltage, voltage waveform, or frequency limits, the battery supplies energy to maintain constant, regulated inverter power output to the load without switching or disturbance.
 - c. If normal power fails, energy supplied by the battery through the inverter continues supply-regulated power to the load without switching or disturbance.
 - d. When power is restored at the normal supply terminals of the system, controls automatically synchronize the inverter with the external source before

- transferring the load. The rectifier-charger then supplies power to the load through the inverter and simultaneously recharges the battery.
- e. If the battery becomes discharged and normal supply is available, the rectifier-charger charges the battery. On reaching full charge, the rectifier-charger automatically shifts to float-charge mode.
 - f. If any element of the UPS system fails and power is available at the normal supply terminals of the system, the static bypass transfer switch switches the load to the normal ac supply circuit without disturbance or interruption.
 - g. If a fault occurs in the system supplied by the UPS, and current flows in excess of the overload rating of the UPS system, the static bypass transfer switch operates to bypass the fault current to the normal ac supply circuit for fault clearing.
 - h. When the fault has cleared, the static bypass transfer switch returns the load to the UPS system.
 - i. If the battery is disconnected, the UPS continues to supply power to the load with no degradation of its regulation of voltage and frequency of the output bus.
2. Manual operation includes the following:
- a. Turning the inverter off causes the static bypass transfer switch to transfer the load directly to the normal ac supply circuit without disturbance or interruption.
 - b. Turning the inverter on causes the static bypass transfer switch to transfer the load to the inverter.

Performance Standards

1. The UPS shall perform as specified while supplying rated full-load current, composed of any combination of linear and nonlinear load, up to 100 percent nonlinear load with a load crest factor of 3.0, under the following conditions or combinations of the following conditions:
 - a. Inverter is switched to battery source.
 - b. Steady-state ac input voltage deviates up to plus or minus 10 percent from nominal voltage.
 - c. Steady-state input frequency deviates up to plus or minus 5 percent from nominal frequency.
 - d. THD of input voltage is 15 percent or more with a minimum crest factor of 3.0, and the largest single harmonic component is a minimum of 5 percent of the fundamental value.
 - e. Load is 50 percent unbalanced continuously.
2. Minimum Duration of Supply: If battery is sole energy source supplying rated full UPS load current at 80 percent power factor, duration of supply shall be 10 minutes unless the Owner's program requirements require more time in which case the duration of supply shall be as indicated.
3. Input Voltage Tolerance: System steady-state and transient output performance remains within specified tolerances when steady-state ac input voltage varies plus 10, minus 15 percent from nominal voltage.

4. Overall UPS Efficiency: Equal to or greater than indicated in the following table:

Nominal Overall UPS Efficiency Ratings			
Size Range of UPS Units	Efficiency at 100% Rated Load	Efficiency at 75% Rated Load	Efficiency at 50% Rated Load
30 KVA and Smaller	86	85	84
37.5 to 74 KVA	89	88	87
75 to 124 KVA	90	88	87
125 to 224 KVA	90	89	88
225 KVA and Larger	90	89	88

5. Maximum Acoustical Noise: maximum allowable values indicated in the following table:

Nominal Overall UPS Audible Noise Ratings		
Size Range of UPS Units	Maximum Noise Value	Distance at which Measured
10 KVA and Smaller	58 dB	36 inches (900 mm)
20 to 125 KVA	60 dB	48 inches (1200 mm)
150 to 300 KVA	78 dB	48 inches (1200 mm)
300 KVA and Larger	83 dB	48 inches (1200 mm)

6. Maximum Energizing Inrush Current: Six times the full-load current.
7. Maximum AC Output-Voltage Regulation for Loads up to 50 Percent Unbalanced: Plus or minus 2 percent over the full range of battery voltage.
8. Output Frequency: 60 Hz, plus or minus 0.5 percent over the full range of input voltage, load, and battery voltage.
9. Limitation of harmonic distortion of input current to the UPS shall be as follows:
- a. Description: Either a tuned harmonic filter or an arrangement of rectifier-charger circuits shall limit THD to 5 percent, maximum, at rated full UPS load current, for power sources with X/R ratio between 2 and 30.
10. Maximum Harmonic Content of Output-Voltage Waveform: 5 percent rms total and 3 percent rms for any single harmonic, for 100 percent rated nonlinear load current with a load crest factor of 3.0.

11. Maximum Harmonic Content of Output-Voltage Waveform: 5 percent rms total and 3 percent rms for any single harmonic, for rated full load with total harmonic distortion up to 50 percent, with a load crest factor of 3.0.
12. Minimum Overload Capacity of UPS at Rated Voltage: 125 percent of rated full load for 10 minutes, and 150 percent for 30 seconds in all operating modes.
13. Maximum Output-Voltage Transient Excursions from Rated Value: For the following instantaneous load changes, stated as percentages of rated full UPS load, voltage shall remain within stated percentages of rated value and recover to, and remain within, plus or minus 2 percent of that value within 100 ms:
 - a. 50 Percent: Plus or minus 5 percent.
 - b. 100 Percent: Plus or minus 5 percent.
 - c. Loss of AC Input Power: Plus or minus 1 percent.
 - d. Restoration of AC Input Power: Plus or minus 1 percent.
14. Input Power Factor: A minimum of [0.70] [0.85] lagging when supply voltage and current are at nominal rated values and the UPS is supplying rated full-load current.
15. Electromagnetic interference emissions: Comply with FCC Rules and Regulations and with 47 CFR 15 for Class A equipment.

26 35 33 Power Factor Correction Equipment

This section might be used in future projects. Verify with UMBSC.

26 36 00 Transfer Switches

Design Standards

1. Provide automatic transfer switches, non-automatic transfer switches, remote annunciator, and control panels through one source from a single manufacturer.
2. Transfer switches shall be monitored by existing campus BMS using BACnet protocol.
3. Switch Characteristics: Designed for continuous-duty repetitive transfer of full-rated current between active power sources.
 - a. Limitation: Switches using molded-case switches or circuit breakers or insulated-case circuit-breaker components are not acceptable.
 - b. Switch Action: Double throw; mechanically held in both directions.
 - c. Contacts: Silver composition or silver alloy for load-current switching. Conventional automatic transfer-switch units, rated 225 A and higher, shall have separate arcing contacts.
4. Use four-pole switches (three phase poles and one neutral pole). Where ground-fault protection is used, a separately switched, fully rated neutral pole may be needed to insure proper operation of the ground-fault relay.

26 41 13 Lightning Protection for Structures**Design Standards**

1. Lightning protection systems shall be included in all new buildings.
2. Lightning protection systems shall be designed in accordance with NFPA 780; UL 96 and UL 96A.
3. Down conductors shall be protected against physical damage with approved raceways. Raceways shall be bonded to down conductors at both ends.
4. All grounding systems (electric, telephone, lightning protection, etc.) are to be interconnected.
5. All metallic raceways, enclosures, frames and other non-current carrying metal parts of electric equipment located within 6'-0" of lightning rod conductors are to be bonded to same. Include a note in the project specifications to cover this.

Product Standards

1. All air terminals, conductors, fasteners, air terminal supports, etc. are to be manufactured from copper.
2. Ground rods shall be $\frac{3}{4}$ " minimum diameter, 8 ft. long copper clad steel.

Performance Standards

1. Installation of the lightning protection system is to be performed by qualified personnel certified by UL or LPI as a Master Installer/Designer, trained and approved for installation of units required for this Project.
2. The lightning protection systems shall be installed in accordance with NFPA 78 and UL 96A standards.
3. Inspection and Certification: Upon completion of the installation, the contractor shall furnish the Master Label issued by Underwriters Laboratories, Inc. for this system. If the protected structure is an addition to or is attached to an existing structure that does not have a lightning protection system, the contractor shall advise the Owner of installation requirements on the existing structure to obtain the Master Label. If the existing structure does have a lightning protection system, the contractor shall advise the Owner of any additional work required on the existing system to achieve compliance with current UL Master Label requirements.

26 42 00 Cathodic Protection

This section might be used in future projects. Verify with UMBS.

26 43 13 Surge Protection for Low-Voltage Electrical Power Circuits**Design Standards**

1. Transient Voltage Surge Suppression (TVSS) shall be provided in all switchboards and panel boards.

26 51 00 Interior Lighting**Design Standards**

1. Use current IES standards and recommendations as the basis of design. Provide lower range recommended levels of even, ambient illumination throughout the space with local task lights providing greater luminance at the task. Power density (watts / SF) shall comply with current FBC and current ASHRAE 90.1 used by USGBC (LEED).
2. Careful consideration must be taken in the design of lighting systems regarding accessibility for servicing of the fixtures and replacement of lamps.
3. Required illumination shall be in the lower range of the current IES recommended levels found in 'The Lighting Handbook.'
4. All lighting projects shall include photometric study.
5. No incandescent or tungsten / halogen lamps are allowed.
6. Provide 4100K color temperature.
7. 2'x2' ceiling layout is preferred at offices, classrooms, and public areas.
8. LED luminaires are preferred, as follows:
 - a. 4,000K light color temperatures at offices, classrooms and general circulation spaces.
 - b. 3,500K light color temperatures at lobbies, lounges, dining, study areas, residential rooms, and similar areas.
 - c. Use the highest CRI whenever possible.
 - d. Select fixtures with the lowest possible glare.
 - e. All fixtures selected by the design professional shall ensure compatibility with Lutron Wireless Maestro controls and sensors.
 - f. Low glare "Wave Stream" technology is preferred for LED panel type fixtures.
 - g. Preferred fixture is Metalux Encounter. Other luminaires with similar performance may be accepted with UMBS Committee approval.
9. Incandescent lamps and halogen are not allowed LED is preferred.

10. Lighting design shall be per IES recommendations. Incorporate task lighting in photometric design.

Product Standards

1. General requirements for lighting fixtures and components:
 - a. Recessed Fixtures: Comply with NEMA LE 4 for ceiling compatibility for recessed fixtures. Fluorescent fixtures must be fully front serviceable.
 - b. Metal Parts: Free of burrs and sharp corners and edges.
 - c. Sheet Metal Components: Steel unless otherwise indicated. Form and support to prevent warping and sagging.
 - d. Doors, Frames, and Other Internal Access: Smooth operating, free of light leakage under operating conditions, and designed to permit re-lamping without use of tools. Designed to prevent doors, frames, lenses, diffusers, and other components from falling accidentally during re-lamping and when secured in operating position.
 - e. Diffusers and Globes:
 - (1) Acrylic Lighting Diffusers: 100 percent virgin acrylic plastic. High resistance to yellowing and other changes due to aging, exposure to heat, and UV radiation.
 - (a) Lens Thickness: At least 0.125 inch minimum unless otherwise indicated.
 - (b) UV stabilized.
 - (2) Glass: Annealed crystal glass unless otherwise indicated.
 - f. Factory-Applied Labels: Comply with UL 1598. Include recommended lamps and ballasts. Labels shall be located where they will be readily visible to service personnel, but not seen from normal viewing angles when lamps are in place.
2. Exit Signs.
 - a. General Requirements for Exit Signs: Comply with UL 924; for sign colors, visibility, luminance, and lettering size, comply with authorities having jurisdiction. At all renovations and additions scopes, use the letter color prevailing in the existing building for consistency and uniform appearance.
 - b. Internally Lighted Signs:
 - (1) Lamps for AC Operation: LEDs, 50,000 hours minimum rated lamp life.
 - (2) Self-Powered Exit Signs (Battery Type): Integral automatic charger in a self-contained power pack.

- a.) Battery: Sealed, maintenance-free, nickel-cadmium type.
 - b.) Charger: Fully automatic, solid-state type with sealed transfer relay.
 - c.) Operation: Relay automatically energizes lamp from battery when circuit voltage drops to 80 percent of nominal voltage or below. When normal voltage is restored, relay disconnects lamps from battery, and battery is automatically recharged and floated on charger.
 - d.) Test Push Button: Push-to-test type, in unit housing, simulates loss of normal power and demonstrates unit operability.
 - e.) LED Indicator Light: Indicates normal power on. Normal glow indicates trickle charge; bright glow indicates charging at end of discharge cycle.
3. Emergency lighting units.
- a. General Requirements for Emergency Lighting Units: Self-contained LED units complying with UL 924.
 - (1) Battery: Sealed, maintenance-free, lead-acid type.
 - (2) Charger: Fully automatic, solid-state type with sealed transfer relay.
 - (3) Operation: Relay automatically turns lamp on when power-supply circuit voltage drops to 80 percent of nominal voltage or below. Lamp automatically disconnects from battery when voltage approaches deep-discharge level. When normal voltage is restored, relay disconnects lamps from battery, and battery is automatically recharged and floated on charger.
 - (4) Test Push Button: Push-to-test type, in unit housing, simulates loss of normal power and demonstrates unit operability.
4. LED Interior Lighting.
- a. Luminaire requirements.
 - (1) Electrical Components, Devices and Accessories: Listed and label as defined in NFPA 70.
 - (2) Factory-Applied Labels: Comply with UL 1598.
 - (3) Recessed luminaires shall comply with NEMA LE 4.
 - (4) NRTL Compliance: Luminaires for hazardous locations shall be listed and labeled for indicated class and division of hazard.
 - (5) California Title 24 compliant.
 - (6) Minimum allowable efficacy of 80 lumens per watt.
 - (7) CRI of minimum 80. CCT of 4100K.
 - (8) Useful life: more than 50,000 hours.

- b. Factory-applied labels.
 - (1) Manufacturer and catalog number.
 - (2) CRI.
 - (3) Color temperature.
 - (4) Listing.

- c. Luminaire Support.
 - (1) Manufacturer and catalog number.
 - (2) CRI.
 - (3) Color temperature.
 - (4) Lighting.

26 55 61 Theatrical Lighting

This section might be used in future projects. Verify with UMBSC.

26 56 00 Exterior Lighting

Design Standards

1. Open parking lots, access thereto, and pedestrian walkways shall be provided with a maintained minimum of 1 foot-candle on the parking surface from dusk until dawn. However, the lighting level may be reduced by fifty (50) percent on non-business days and commencing thirty (30) minutes after the termination of business on each operating day. The uniformity ratio shall not exceed a twelve to one ratio (10:1) maximum to minimum foot-candles (per I.E.S).
 - a. Design exterior lighting so that all site and building-mounted luminaires produce a maximum initial illuminance value no greater than 0.10 horizontal and vertical foot candles at UM property boundary and, no greater than 0.01 horizontal foot candles 10 feet beyond UM property boundary. Document that no more than 2% of the total initial designed fixture lumens (sum total of all fixtures on site) are emitted at an angle of 90 degrees or higher from nadir (straight down). (per LEED v2009 - Confirm with current version at project time).
 - b. All campus signage including building names shall be illuminated. Light levels shall be per current IES Standards. Lighting power densities shall comply with current Florida Building Code and current ASHRAE 90.1 used by USGBC (LEED).
 - c. Outdoor automatic teller machines (ATMs) shall comply with Florida Statute 655.960.

- (1) There shall be a minimum of 10 candle foot power at the face of the automated teller machine, extending in an unobstructed direction outward 5 feet.
 - (2) There shall be a minimum of 2 candle foot power within 50 feet in all unobstructed directions from the face of the automated teller machine. If the automated teller machine is located within 10 feet of the corner of the building and the automated teller machine is generally accessible from the adjacent side, there shall be a minimum of 2 candle foot power along the first 40 unobstructed feet of the adjacent side of the building.
 - (3) There shall be a minimum of 2 candle foot power in that portion of the defined parking area within 60 feet of the automated teller machine.
 - (4) The operator shall provide reflective mirrors or surfaces at each automated teller machine which provide the customer with a rear view while the customer is engaged in using the automated teller machine.
 - (5) The operator, or other person responsible pursuant to ss. 655.960-655.965 for an automated teller machine, shall ensure that the height of any landscaping, vegetation, or other physical obstructions in the area required to be lighted pursuant to subsection (1) for any open and operating automated teller machine shall not exceed 3 feet, except that trees trimmed to a height of 10 feet and whose diameters are less than 2 feet and manmade physical obstructions required by statute, law, code, ordinance, or other governmental regulation shall not be affected by this subsection. (per 2010 Florida Statutes 655.962).
2. All lighting projects shall include photometric studies.
 3. Provide independent service meters for new parking lots and campus lighting zones.
 4. No incandescent or sodium lamps allowed.
 5. All exterior light to be full cut-off, horizontal mount, zero sky pollution, glare free. BUG rating shall be B1 U0 G0; alternate BUG rating luminaires require approval by UMBSC.
 6. Parking lots and streets 4100K light color temperature.
 7. Pathways and plazas: 4100K light color temperature.
 8. Landscape lighting: 3500K light color temperature.
 9. Tree limb mounted LED "moonlighting" (6000K or higher) shall be considered on a per project basis.
 10. Minimize the number of transformers/drivers in the landscape lighting design.
 11. Pathway fixture: basis-of-design: CREE LEDWay, Type II (preferred), 60' o.c. (to be confirmed by photometrics), 18" horizontal aluminum tube arm. The use of alternate fixtures requires the approval of the UMBSC.
 12. Plaza fixture: basis-of-design: CREE LEDWay; Type and power requirements as per photometrics. The use of alternate fixtures requires the approval of the UMBSC.

13. Parking lot/street fixture: basis-of design: CREE LEDWay; Type and power requirements as per photometrics. The use of alternate fixtures requires the approval of the UMBSC.
14. Parking structure: basis-of-design: CREE VG pendant, type V medium, 4,000k, silver finish, programmable multi-level; Type and power requirements as per photometrics. The use of alternate fixtures requires the approval of the UMBSC.
15. Fountains: Base of design: Philips LED, low voltage submerged luminaires.
16. New exterior light fixtures and arms shall receive factory applied coating color: RAL 6012.
17. Small quantity partial retrofit of fixtures and/ or poles at parking lots, street, plaza, and walkways, shall match the prevailing existing conditions. In the case of substantial or complete retrofits, fixtures and arms shall have a custom factory coat using, RAL 6012 color.
18. Bollard light fixtures: Basis of design: Landscape forms Annapolis, 6" DIA, 42" H, silver finish, fixed or removable according to program requirements. The use of alternate fixtures require the approval of the UMBSC.
19. Landscape up-lights: provide 8" diameter, mounted 12" AFF on concrete base.

Product Standards

1. All poles shall be precast concrete 15' high above finish grade with 2 internal 3/4" or 1" conduits (verify conduit size with UM project manager), 2-3/8" dia. tenon, and a secondary J.B. 36" below the top for CCTV use.
Paint flat Sherwin Williams #SW 2809.
2. All exterior lighting sources shall be LED, CRI 80 (minimum) 4100 K, 50,000 hours minimum.
3. All exterior lighting fixtures subject to physical damage shall be vandal and windstorm resistant. Fixtures shall be classified by the fixture manufacturer as "vandal resistant."
4. Photocells used for operating exterior lighting shall be solid state, with dry contacts, to operate connected relay, contactor coils, or microprocessor input. They shall comply with UL 773A, and the following requirements:
 - a. Listed and labeled as defined in NFPA 70, by a qualified testing agency, and marked for intended location and application.
 - b. Light-Level Monitoring Range: 1.5 to 10 fc (16.14 to 108 lux), with an adjustment for turn-on and turn-off levels within that range, and a directional lens in front of the photocell to prevent fixed light sources from causing turn-off.
 - c. Time Delay: Fifteen second minimum, to prevent false operation.
 - d. Surge Protection: Metal-oxide varistor.
 - e. Mounting: Twist lock complies with NEMA C136.10, with base-and-stem mounting or stem-and-swivel mounting accessories as required to direct sensor to the north sky exposure.

Performance Standards

1. A drawing is required, depicting computer generated photometric foot candle calculations showing maintained light levels on a 10' x 10' grid for all parking and pedestrian area projects.
2. Exterior or parking garage lighting shall not be placed in permanent use until a letter of compliance from a registered professional engineer has been provided stating that the installation has been field checked and meets Miami-Dade County requirements.

26 56 68 Exterior Athletic Lighting

This section might be used in future projects. Verify with UMBSC.

UNIVERSITY
OF MIAMI



DIVISION 27 COMMUNICATIONS

NOTE: Division 27 content is current as of 11/2018; the format will be updated in the next UMBS revision, to match the other divisions.

Telecommunication Wiring Standards

Rev Date: January 3, 2019

Contents

1. Introduction.....	3
2. Standards and Codes	4
3. Cable Pathway and Spaces	7
3.1 Outside Conduit.....	7
3.2 Intra-Building Conduit and Cable Support Structures	8
3.3 Telecommunication Spaces	10
4. Cabling and Wiring, For Reference Only	14
4.1 Copper Distribution Cable	14
4.2 Fiber Optic Cable	16
4.3 Horizontal Station Wiring.....	17
5. FIRE-STOPPING	22
5.1 Riser Cables.....	22
5.2 Entrance Cable.....	22
5.3 Firewall Penetrations.....	22
5.4 Material and Installation	22

1. Introduction

The University of Miami Information Technology (UMIT) department provides design requirements for the telecommunications infrastructure. UMIT gives its comments to the architects through the Facilities Design and Construction office's project manager. The following are the tasks, but not limited to;

- UMIT designs both outside plant (OSP) and structured cabling system (SCS) telecommunications cabling schemes for the building.
- UMIT gives Facilities Design and Construction (FD&C) a cost estimate for the cabling. This estimate includes OSP, SCS, voice/ data cabling and networking equipment budget for new buildings. UMIT specifies the networking equipment, sees that it is included in the budget, orders it and installs it once the building is complete. The architect is not concerned with any aspects of the networking equipment, aside from providing sufficient space, environmental considerations and power (at UMIT's direction).
- When a building project is planned for the University of Miami, FD&C architects, engineers and their consultants design physical pathways for the telecommunications cables by following these specific guidelines.
- These guidelines address specific requirements for the design of telecommunications infrastructure in new buildings for the University of Miami. It does not include Fire Alarm Systems, Distributed Antenna Systems, Access Control/Security Systems, Energy Management, Environmental Control, Paging Systems, and Audio Visual
- The purpose of this document is to provide the FD&C project managers, architects, engineers and consultants with guidelines to use in the early planning stages of a project that are relevant to the design of telecommunications pathways and the University of Miami Facilities Management may also use these guidelines. Use the information in this document to make design-related decisions that meet the requirements of the University of Miami and meet the needs of the building and its future occupants with respect to telecommunications.
- Coordinate with UMIT telecommunications representative any deviation from standards- based Comply with code requirements completely.

2. Standards and Codes

All recommended media and installation procedures shall, wherever applicable, meet and/or exceed all accepted industry codes and standards, including those presented by the following organizations:

- American Insurance Association: National Building Code (NBC)
- Building Officials and Code Administrators (BOCA): The BOCA Basic Building Code
- Institute of Electrical and Electronics Engineers (IEEE): National Electric Safety Code
- International Conference of Building Officials (ICBO): Uniform Building Code (UBC)
- National Fire Protection Association (NFPA): Life Safety Code, Lightning Protection Code, National Electric Code (NEC)
- Southern Building Code Congress International, Inc.: Standard Building Code (SBC)
- Building Industry Consulting Service International (BICSI): Telecommunications Distribution Methods Manual Eleventh Edition
- National Electrical Manufacturers Association (NEMA)
- National Society of Professional Engineers (NSPE)
- Underwriters Laboratories (UL)
- State, County, and City Codes
- Manufacturers Recommendations
- ANSI/TIA/EIA-568-C.0 "Generic Telecommunications Cabling for Customer Premises" and addenda
- ANSI/TIA/EIA-568-C.1 "Commercial Building Telecommunications Cabling Standard" and addenda
- ANSI/TIA/EIA-568-C.2 "Balanced Twisted-Pair Telecommunications Cabling and Components Standard" and addenda
- ANSI/TIA/EIA-568-C.3 "Optical Fiber Cabling Components Standard" and addenda
- ANSI/TIA/EIA-568-C.4 "Broadband Coaxial Cabling and Components Standard" and addenda
- ANSI/TIA/EIA-569-C "Telecommunications Pathways and Spaces" and addenda
- ANSI/TIA/EIA-598-C "Optical Fiber Cable Color Coding" and addenda

- ANSI/TIA/EIA-606-B” Administration Standard for the Telecommunications Infrastructure” and addenda
- ANSI/TIA/EIA-607-B” Commercial Building Grounding (Earthing) and Bonding Requirements for Telecommunications” and addenda
- ANSI/TIA/EIA-758-B” Customer-Owned Outside Plant Telecommunications Infrastructure Standard” and addenda
- ANSI/TIA/EIA-862-A” Building Automation Systems Cabling Standard” and addenda
- ANSI/TIA/EIA-942-A” Telecommunications Infrastructure Standard for Data Centers” and addenda
- ANSI/TIA/EIA-526-7 ”Measurement of Optical Power Loss of Installed Single-Mode Fiber Cable Plant” and addenda
- ANSI/TIA/EIA-526-14-B-2010 ” Optical Power Loss Measurements of Installed Multimode Fiber Cable Plant; IEC 61280-4-1 Edition 2, Fiber-Optic Communications Subsystem Test Procedure- Part 4-1: Installed Cable Plant- Multimode Attenuation Measurement.” and addenda
- ANSI/TIA-1152–2009, “Requirements for Field Test Instruments and Measurements for Balanced Twisted-Pair Cabling” and addenda
- ANSI/TIA-1179–2010, Healthcare Facility Telecommunications Infrastructure Standard” and addenda
- IEC/TR3 61000-5-2 - Ed. 1.0 “Electromagnetic compatibility (EMC) - Part 5: Installation and mitigation guidelines - Section 2: Earthing and cabling” and addenda
- ISO/IEC 11801-1:2017” Information technology - Generic cabling for customer premises” and addenda
- CENELEC EN 50173:2011” Information Technology - Generic cabling systems” and addenda
- Install cabling in accordance with the most recent edition of BICSI® and INFOCOMM publications:
 - BICSI – Telecommunications Distribution Methods Manual
 - BICSI – Information Technology Systems Installation Methods Manual
 - BICSI – Outside Plant Design Reference Manual
 - ANSI/BICSI– Electronic Safety and Security Design and Implementation Best Practices

- ANSI/BICSI 001-2017, Information and Communication Technology Systems Design and Implementation Best Practices for Educational Institutions and Facilities
- ANSI/BICSI 004-2012, Information Technology Systems Design and Implementation Best Practices for Healthcare Institutions and Facilities
- INFOCOMM, AV/IT Infrastructure Guidelines for Higher Education

Where discrepancies exist as to applicability of the codes and standards, the most stringent requirements will be adhered to by the successful contractor.

3. Cable Pathway and Spaces

3.1 Outside Conduit

3.1.1 Underground Conduit

New buildings must be connected to the UMIT Telecommunications underground conduit system. The project may need to install new manholes and/or hand holes. A UMIT representative will advise where the point of connection should be and will recommend a route for the new conduits.

- In some circumstances, new additional conduits may need to be installed to augment an existing conduit run.
- Design entrance conduits so that they slope away from the building to prevent water from entering the If this is not practical then provide the manhole with a drainage system.
- Where underground ducts are required, the duct type will be a minimum of (4)-4 inch of corrosion resistant conduit (fiber, fiberglass, concrete, rigid galvanized metal or rigid and non-rigid non-metallic) for entrance into the building. All ducts are to contain a 3/8" plastic or nylon line with a minimum of 200 lbs. of pulling tension. Below grade entry point to extend 4" above finished floor.
- Conduit runs shall have no more than (2) 90 degree of bends between pulling points which should not exceed 450 feet. Bend radiuses must be no less than 10 times the inside diameter of the conduit except where specified.
- Conduits should have a minimum of 24 inches of covered earth with a spacing of 1 inch between conduits filled in with sand or pea rock. A protective blanket of at least 2 inches of sand or pea rock must be above and below the conduit(s).
- A buried marker tape is to be placed 12 inches below grade. The warning tape can be non-detectable or detectable.
- Separation Requirement of communication conduit from power is 3 inches of concrete or 12 inches of well-tempered earth and the separation requirement from pipes (gas, oil, water) is 6 inches when crossing and 12 inches when parallel.

3.1.2 Inner duct, Existing Installations

- Inner ducts will be 1 inch, Optic-Gard/PE Polyethylene Corrugated Conduit or equivalent product, and are to contain a 1/4" poly-rope or Aramid Yarn Tape.
- Inner ducts shall be color coded to aid the localization of cables.
- Inner ducts are to be free of kinks and are to be one continuous piece from access point to access point.

3.1.21 MaxCell, New Installations

For use in 4" or conduits, the 3" 3-Cell product with detectable meal tape is the standard.

3.1.3 Man Holes and Hand Holes

Man-holes (MH) should be of a minimum of 6 feet by 12 feet with a depth of 9 feet. All frames and covers used to be used in roads or driveways must be traffic rated. All covers must have the appropriate identifications (e.g. T-Telephone).

The concrete strength used for MH's should be at a minimum of 3480 psi and the MH's are to be placed on 6 inches of rock or sand to ensure uniform distribution of soil pressure on floor.

All MH hardware must be galvanized and equipped with bonding inserts, struts for racking pulling eyes with a minimum of 7/8 inch in diameter, a slump of a minimum 8 inch diameter an entry ladder and noncorrosive metal tag in MH collar that denotes MH size and volume. All holes must have plugs in place when not being occupied and properly sealed when occupied.

Most hand-holes (HH) will be Brooks series 200 48" x 30" or equivalent. All HH's are to be placed on 6 inches of rock or sand to ensure uniform distribution of soil pressure on floor. All frames and covers used to be used in roads or driveways must be traffic rated.

Butterfly Details will be provided for all new manholes installed. The manhole number will be painted on each interior wall as well as the cardinal compass directions.

3.2 Intra-Building Conduit and Cable Support Structures

3.2.1 Backbone Riser Conduit

Conduit systems within a building are to be constructed using EMT or IMC (where applicable) type pipe. Systems shall consist of no bend greater than 90 degrees or no more that (2) 90 degree bends between pull points or pull boxes. Conduits must be bonded to ground on one or both ends. On runs of more than 100 feet in lengths pull boxes or pull points should be inserted. The pull point must be a pull-box, constructed of galvanized steel that will accommodate a worst case bend radius of 10 x the diameter of the conduit. (Example: for a 4" conduit the smallest pull box radius would be 40").

Vertically aligned communications riser closets should have a minimum of 4-4" for 40,000 sq. ft. of usable floor space between each closet. Slots are to have a minimum of 1 inch high curb and sleeves are to extend 1 inch above the floor level and will be located adjacent to a wall on to which the cable can be supported. The proper fire stopping is to be maintained at all times.

3.2.2 Cable Tray

Size and type of cable tray to be determined by amount of cable required by project. It is important that the path for the cable tray is clear of obstructions, such as HVAC ducts, large pipes, and structural beams within the building. Where fire or smoke barriers are penetrated by the cable tray, they shall be fire stopped to maintain the rating of the barrier. Alternatively, conduit sleeves may be used through the penetrations. They must be fire stopped as well. The number of sleeves required depends on the number of cables and size of the tray. Use 40% fill ratio to

determine the number of sleeves. Two additional spare sleeves should be installed to accommodate future cable placement.

Place cable trays above drop ceilings in corridors. Do not place them above offices or inaccessible spaces. There must be at least 4 inches of vertical space between the suspended ceiling tile and the bottom of the cable tray; 12 inches of vertical clearance from the top of the cable tray is required; and 2' total side clearance (meaning, if the cable tray is wall mounted and there is no clearance on one side, then minimum clearance on the other side should be 2').

To connect the TR to the cable tray, 4" conduits should be used. The number of 4" conduits required depends on the number of cables and size of tray. Use 40% fill ratio to determine the number of 4" conduits. Two additional spare conduits should be installed to accommodate future cable placement.

3.2.3 Station Conduits

Station location conduits are to be 1 inch or 1 ½" with 4"x4" by 2 ½" deep 1900 type outlet boxes. It is preferred not to have these located on outside walls.

The station conduits must comply with one of the following:

- Home run to the Communications Closet serving the location. If using this method, the conduit shall have no more than (2) pull points. Each section between pull points shall have no more than (2) 90 degree of bends and shall not exceed a maximum length of 100 feet. Conduits must have a pull string in each section. (NO CONDULETS, LBs, Flex or Smurf pipe)
- Stubbed up above the drop ceiling within 1'- 3' to the nearest cable tray.
- Placed in the slab with no more than 180 degrees of bend, with a maximum length of 100 feet.
- The bend radius must be at least six times the inside diameter of the conduit for conduits under 2 inches.
- All conduit ends should have connectors, bushings and be equipped with a pull string in each section.
- All conduits must be home run, no "Daisy Chaining".
- All conduits and boxes should be painted green for easy identification.
- All conduits must accommodate future Cat 6A cabling

3.2.4 Miscellaneous

3.2.4.1 Elevator Conduits

- We will require a 6"x6"x6" box to house electronics in or near the elevator controls, from there a 1' conduit to the elevator controls home run to the nearest Communications Closet serving the location. The conduit shall have no more than (2) pull points. Each section between pull points shall have no more than (2) 90 degree of bends and shall not exceed a maximum

length of 100 feet. Conduits must have a pull string in each section. (NO CONDULETS, LBs, Flex or Smurf pipe)

3.2.4.2 Fire Alarm Conduits.

- We will require a 4"x4" by 2 1/2" deep 1900 box to house electronics near the Fire Alarm Panel, from there a 1' conduit to the Fire Alarm Panel home run to the nearest Communications Closet serving the location. The conduit shall have no more than (2) pull points. Each section between pull points shall have no more than (2) 90 degree of bends and shall not exceed a maximum length of 100 feet. Conduits must have a pull string in each section. (NO CONDULETS, LBs or Smurf pipe)

3.2.4.3 Floor Boxes.

- Size and type of floor box will be determined by amount of cables required, each trade will have its own conduit, Electrical, Telecom and A/V...
- Will be fed via 1" minimum conduit from floor box to the accessible ceiling space on floor it serves.

3.3 Telecommunication Spaces

3.3.1 Equipment Room (ER) / Main Distribution Frame (MDF)

The equipment room (ER) must meet EIA/TIA 569 Commercial Building Standard for Telecommunications Pathways and Spaces and will be capable of accommodating future growth, spaced for required equipment. The space allotted for the ER should be at least 10 feet by 16 feet. The ER should have access for the delivery and installation of large equipment and cables with proximity to electrical services mechanical equipment. The ER room must also provide an environment that supports the data network distribution such as switches, routers...etc. The location of the ER should have access to service entrances for telecommunications and electrical power. There shall not be any other conduits or services passing vertically or horizontally in the Equipment room. An example would be a roof drain or water pipe entering and leaving our Equipment room.

The minimum requirements are as follows;

1) Floor Requirements

- a) Minimum commercial floor loading of 50 to 250 pounds per square foot and for distributed loading it must be greater than 100 pounds per square foot. The rating for concentrated loading is 2,000 pound per feet. The floor must be level within 1/8 inch over 8 linear feet.
- b) Floor surface must be free be within the EIA/TIA 569 Vibration design limits of 5-22 Hz .01 inches double amplitude displacement, 22-500 Hz 0.25 g peak acceleration and 500-22 and 22-5 Hz 0.25 g peak acceleration inches double amplitude displacement.
- c) The surface should be covered with a material that is durable and dust free (linoleum or paint), no carpet.

- 2) Uniform illumination of 50 foot-candles at a height of 3 feet (0.9m) above the floor. Suspended overhead lighting should, when possible, maintain 11 inch (279.4 mm) clearance from the communications equipment including cable supporting hardware. Lighting fixtures should be at a minimum of 8.5 feet AFF.
- 3) Walls and ceiling must be sealed and dust free. They must be painted a light color as to aid in the illumination of the room, white is the preferred color. All the walls must be covered from 18" AFF maximum to 8' AFF minimum with $\frac{3}{4}$ inch A/C grade or better, void free plywood back board with the C grade facing the wall. The plywood backboard should be painted on all six sides with a fire retardant paint light color; light gray is the preferred color. No drop ceiling are allowed in the room.
- 4) Doors must have a minimum height of 84 inches (2,134 mm) and a minimum width of 36 inches (914 mm). The door and frame should provide adequate security and prevent outside dust from entering the room. When possible the door should swing out so as to allow maximum use of the interior of the telecommunications room.
- 5) All ER's require a controlled environment in which the heating and A/C will provide an ambient temperature between 64° F and 70° F with a relative humidity range of between 30 and 55 percent, 24 hours a day 7 days a week
- 6) A grounding bar must be installed in an accessible location and attached to the building common ground of #0 or larger. (The UM Dept. of Telecommunications will provide the ground bus bar).
- 7) Electrical
 - a) The room must have a minimum of (4) dedicated, 20 amp 120 Volt non-switched alternating current (ac) duplex receptacles for equipment power. Separate duplex convenience receptacles for use by technicians for tools, instruments...etc. These should be 6 inches above finished floor (AFF) and placed at 6 feet intervals around inner walls. The room must have a minimum of (2) L5-30, 30 amp 120 Volt receptacle, (2) L6-30, 30 amp 208 Volt receptacle and (1) 70 amp 208 hardwired outlet. When a UPS is provided the outlets should be fed from the specified Power Distribution Unit (PDU), which is purchased and installed by UM Telecom. Each and every Equipment room shall have an appropriate access to the building common ground. This is a baseline estimate and will vary depending on amount of network equipment deployed.
 - b) Any equipment within the ER must be in accordance with the manufactures specifications.
 - c) If the building has a backup generator with sufficient capacity, the room's electrical service should be included in the generator's configuration.
- 8) Fire Suppression
 - a) Sprinkler Heads: must be set to operate at temperatures of 212° F or higher.
 - b) It is preferred that the supply pipe to the sprinkler heads have a Pre-Action System installed.

3.3.2 Telecommunication Room

The telecommunications room (TR) must meet EIA/TIA 569 Commercial Building Standard for Telecommunications Pathways and Spaces and will be capable of housing voice X-connect systems and Data Network Equipment as specified by the University of Miami or its designate. The room may also provide an environment that supports but not limited to security equipment, energy management equipment. The room location must be kept free from electromagnetic radiation such as X-ray equipment, radio transmitters or radar transmitters. The default measurements for the TR are 8 feet wide and 10 feet long. The rooms must align vertically. The TR should only serve 10,000 square feet of usable space unless the horizontal cable lengths do not exceed the required 295 feet length. There shall not be any other conduits or services passing vertically or horizontally in the TR. An example would be a roof drain or water pipe entering and leaving our TR.

The minimum requirements are as follows;

- 1) Floor Requirements-
 - a) Minimum commercial floor loading of 50 pounds per square foot. The floor must be level within 1/8 inch over 8 linear feet.
 - b) Floor surface must be free and within the EIA/TIA 569. Vibration design limits of 5-22 Hz .01inches double amplitude displacement, 22-500 Hz 0.25 g peak acceleration and 500-22 and 22-5 Hz 0.25 g peak acceleration inches double amplitude displacement
 - c) The surface should be covered with a material that is durable and dust free tiled or painted no carpet.
- 2) Uniform illumination of 50 foot-candles at a height of 3 feet above the floor. Suspended overhead lighting should, when possible, maintain 11 inch clearance from the communications equipment including cable supporting hardware. Lighting fixtures must be at a minimum of 8.5 feet AFF.
- 3) Walls and ceiling must be sealed and dust free. They must be painted a light color as to aid in the illumination of the room, white is the preferred color. All the walls must be covered from 18" AFF maximum to 8' AFF minimum with ¾ inch A/C grade or better, void free plywood back board with the C grade facing the wall. The plywood backboard should be painted on all six sides with a fire retardant light colored paint, light gray is the preferred color. No drop ceiling is allowed in the room.
- 4) Doors must have a minimum height of 84 inches and a minimum width of 36 inches. The door and frame should provide adequate security and prevent outside dust from entering the room. Double doors are to be without a center post. When possible the door should swing out so as to allow maximum use of the interior of the telecommunications room.
- 5) All TR's require a controlled environment in which the heating and A/C will provide an ambient temperature between 64° F and 70° F with a relative humidity range of between 30 and 55 percent, 24 hours a day 7 days a week.
- 6) A 12 lug grounding bar must be installed in an accessible location and attached to the building common ground with a number 6 AWG solid or larger wire.
- 7) Electrical
 - a) The room must have a minimum of (4) dedicated, 20 amp 120 Volt non-switched alternating current (ac) duplex receptacles for equipment power. Separate duplex

convenience receptacles for use by technicians for tools, instruments...etc. These should be 6 inches above finished floor (AFF) and placed at 6 feet intervals around inner walls. The room must have a minimum of (2) L5-30, 30 amp 120 Volt receptacle, (2) L6-30, 30 amp 208 Volt receptacle and (1) 70 amp 208 hardwired outlet. When a UPS is provided the outlets should be feed from the specified Power Distribution Unit (PDU), which is purchased and installed by UM Telecom. Each and every communications room shall have an appropriate access to the building common ground. This is a baseline estimate and will vary depending on amount of network equipment deployed.

- b) Any equipment within the ER must be in accordance with the manufactures specifications.
 - c) If the building has a backup generator with sufficient capacity, the room's electrical service should be included in the generator's configuration.
- 8) Fire Suppression
- a) Sprinkler Heads: must be set to operate at temperatures of 212 degrees F or higher.
 - b) It is preferred that the supply pipe to the sprinkler heads have a Pre-Action System installed.

4. Cabling and Wiring, For Reference Only

4.1 Copper Distribution Cable

4.1.1 Copper Distribution Cable Specifications:

All telephone voice grade cable is to be solid bare copper 24 AWG wire with an inner layer of foam insulation covered by an outer layer of telephone industry accepted color coded solid colored polyolefin jacket. The outer sheath must have an identification marker including Manufacturing ID, pair, count and gage and footage. The identification marker must appear every 2 ft.

In buried or underground applications the cable is to be filled with a compound that aids in the prevention of moisture penetration, an electrically continuous corrugated metallic turn-plate, and an outer black polyethylene sheath.

Riser cables shall have the proper UL fire rating sheath (riser rated in conduit or stacked riser system and plenum rated when installed in a return air plenum area) and an electrically continuous corrugated metallic turn-plate.

4.1.2 Placing Copper Distribution Cable:

Placement of copper cable shall be performed in compliance with manufacturer's recommendations. Any cable damaged during placement will be replaced by the contractor at no cost to the University of Miami. Bend radius should not be less than eight times the diameter of the cable.

4.1.3 Splicing and Termination of Copper Distribution Cable:

- All copper splicing shall be performed with Lucent Technologies 710 splicing modules.
- Splices must be properly bonded, cased, and encapsulated when applicable.
- All cables must be properly supported in buildings & man-holes according to industry standards.
- Splices shall be set up using the fold-back method.
- All splices will be pressure tested before encapsulate is poured

The termination of entrance cables will be done as follows:

1. In Building Entrances, where required, 190 type protector tails will terminate on 66M1-50's mounted to 183-A-2 or 183-B-2 green backboards equipped with 89B brackets unless otherwise noted.
2. In the MDF's 190 type protector tails will terminate on 110 blocks mounted to a distribution frame. (Refer to Approved Material List)

3. Splice closures must have vacant holes plugged and cable entrances must be sealed properly with washers, sealing tape and cord.

4.1.4 Grounding and Bonding

Grounding shall meet the appropriate NEC requirements and practices except where other authorities or codes impose a more stringent requirement or practice. When compatible with required electrical codes, the grounding instructions and requirements of the equipment manufacturer should also be followed. Each and every communications closet shall have an appropriate access to the building common ground. All equipment and hardware must be connected to the building common ground in accordance with manufactures specifications a minimum number 6 AWG solid wire must be used in grounding applications.

4.1.5 Entrance Cable Protection

All copper telephone cables, underground buried or aerial ,that are placed between unattached buildings must be protected on each end with the use of proper cable pair protection equipment. Cable pair protection must be Circa 190 Type or if an entrance cable is 100 pairs or less 189 type protectors may be used. All protectors must be properly grounded and bonded.

4.1.6 Tagging and Labeling

- All cables entering a building must be tagged and labeled.
- All cables entering a communication closet must be tagged and labeled.
- All cables placed underground will be tagged and labeled in each Man-hole or Hand-hole through which it passes.
- The tag shall contain such information as cable designation and count; example: Centrex 5 cable, pairs 1 to 300 would read CEN 05:1-300 as well as date installed.
- A riser diagram in Visio depicting all copper cables and their labels will be provided upon job completion

4.1.7 Testing & Acceptance

- An end-to-end continuity test must be performed on all cable pairs.
- A loop resistance test must be performed on one pair in each 25 pair compliment. Loop resistance shall not exceed 27.3 ohms per kft.
- An insertion loss test must be performed on one pair in each 100 pair compliment. Attenuation loss shall not exceed 5.6 dB per kft @ 68° F on filled cable and 5.9 dB per kft on air core riser cable.
- Test results are to be furnished in spread sheet form to the University of Miami Department of Telecommunications

4.2 Fiber Optic Cable

4.2.1 Fiber Optic Cables Specifications

Fiber optic cables may contain a different configuration of Multi-Mode and Single-Mode fibers within the same outer sheath.

In buried or underground applications the cable is to be of loose tube construction with the tubes having a fill compound that aids in the prevention of moisture penetration. The cable must have a dielectric strength member that is continuous. The outer sheath shall be a black polyethylene sheath.

The fibers in the cable may be comprised of one or both of the following types:

- Multi-Mode fibers 62.5 micron core with 125 micron cladding dual window.
- Multi-Mode fiber 50 micron 50 micron core 125 micron core cladding
- Single-Mode Fibers must be 8.3 micron core with 125 micron cladding.

4.2.2 Placing

Placement of fiber cable shall be performed in compliance with manufacturer's recommendations. Any cable damaged during placement will be replaced by the contractor at no cost to the University of Miami. It is required to have 20 foot slack loop in each Man-hole and a 30 foot slack loop in each end.

4.2.3 Fiber Optic Connectors & Termination Methodology

All fiber optic connectors will be Corning, ceramic or composite, "ST", "SC or other to be specified by the specific use", Epoxy Heat, UV Cured or mechanical. All fiber optic connecting hardware, connectors, cable, etc., will be installed and terminated abiding with all pertinent standards, codes and manufacturers recommended installation procedures. The termination methodologies acceptable are UV, Heat Cured or Cam Locking Mechanical. Only a dB loss of 0.75 or less per connector or 1.5 dB per connector pair will be acceptable.

4.2.4 Fiber Optic Connecting Hardware

All fiber optic connecting hardware will be Corning and will be identified in the scope of work. (Refer to Hardware and Material specifications) Example: WCH, CCH, PCH etc.

4.2.5 Tagging and Labeling

Fiber cables entering a building or entering a Communication Closet will be tagged and labeled. Cables placed in the underground will be tagged and labeled in each Man-hole or Hand-hole

through which it passes. The tag shall contain such information as cable designation and count. The tags are to be yellow and shall read in bold letters "FIBER OPTIC CABLE".

A riser diagram in Visio depicting all fiber cables and their labels will be provided upon job completion.

4.2.6 Testing & Acceptance

4.2.6.1 MULTIMODE BACKBONE FIBER

Unidirectional insertion loss (Power Meter) attenuation test; @ 850 nm and 1330 nm wavelength and unidirectional OTDR test @ 850 nm and 1330 nm wavelength on each Multimode fiber. Each fiber shall not exceed 3.5 dB per km and must provide a minimum of 160 MHz of bandwidth per km @ 850 nm. Also, each fiber shall not exceed 1.5 dB per km and must provide a minimum of 500 MHz of bandwidth per km @ 1330 nm.

4.2.6.2 SINGLEMODE BACKBONE FIBER

Unidirectional insertion loss (Power Meter) attenuation test; @ 1300 nm and 1550 nm wavelength and unidirectional OTDR test @ 1300 nm and 1550 nm wavelength on each Single mode fiber. Each fiber shall not exceed 1.5 dB per km @ 1300 nm. Also each fiber shall not exceed 1.25 dB per km @ 1550 nm.

Premises optical fiber links should be tested bi-directionally and at their two corresponding wavelengths (multimode at 850 nm and 1300 nm; single mode at 1310 and 1550nm). Because length and potential number of connections and splices vary depending on site conditions, an attenuation equation is used to determine worst-case acceptance values based on standard component requirements at applicable wavelength.

Test results are to be furnished to The University of Miami Department of Telecommunications in spread sheet form.

4.2.7 Warranty

Fiber optic cable will be Corning or the manufactures and the contractor must be able to provide Manufacture extended warranty

4.3 Horizontal Station Wiring

4.3.1 Voice Cable

All voice station wiring shall be Cat 6 four pair with plenum jacket and conform to EIA / TIA 568 "Commercial Building Wiring Standard". The jacket must be gray in color.

4.3.2 Voice Cable Termination:

Voice station cables are to be terminated in the communications closet on 66M1-50 blocks, the termination blocks are to be mounted to 183-A-1 or 183-B-1 (Blue) back boards. 110 style terminations are also permitted. Cables are to be neatly routed with the use of D Rings. Wire management shall be provided above and/or below the termination field.

The station end of the cable will be terminated on an "Information Outlet" in compliance with the 568B wiring standard using the hardware specified in the scope of work. (Refer to UM Hardware and Material Specifications.)

4.3.3 Voice Cable Testing & Acceptance:

Voice cables are to be tested end-to-end for continuity and compliance to 568B wiring pin configuration standard.

4.4 Data Cat 6 Cables

4.4.1 Data Cat 6 Cable:

All Data Cat 6 cables shall have a plenum jacket, blue in color and comply with and be installed in accordance with EIA/TIA 568 "Commercial Building Wiring Standard" and EIA/TIA TBS 36 "Telecommunications Systems Bulletin-Additional Transmission Specifications for Unshielded Twisted Pair Connecting Hardware"

4.4.2 Data CAT 6 Cable Termination:

Data cables are to be terminated in the communication closet onto a CAT 6 angled High Density (HD) patch panels. On the station side they are to be terminated in an "Information Outlet" equipped with Cat 6 RJ45 Outlet using the 568B wiring standard.

4.4.3 Data CAT 6 Cable Termination:

4.4.3.1 PATCH PANELS:

Cat 6 patch panels shall be equipped with 8 pin RJ45 CAT 6 modular jacks and comply with EIA/TIA 568 "Commercial Building Wiring Standard" and EIA/TIA TBS 36 "Telecommunications Systems Bulletin-Additional Transmission Specifications for Unshielded Twisted Pair Connecting Hardware." The wiring scheme is to be 568 B.

4.4.3.2 INFORMATION OUTLETS:

"Information Outlets" will use 8 pin RJ45 non-keyed modular jacks for voice cables and CATEGORY 6, 8 pin RJ45 non keyed modular jacks for data cables. Only twelve inches of slack should exist at the Information Outlet with no more than 2.5 inches of sheath (jacket) removed for termination. The individual cable pairs must not be untwisted more than 1/2 inch from termination block. If ICONS are used, gray will designate voice and blue will designate data. The wiring scheme is to be 568 B.

4.4.4 Data Cat 6 Cable Testing & Acceptance

Category 6 cables are to be tested end-to-end for continuity and compliance with EIA/TIA specifications and to 568-A standards. Category 6 must meet the Basic Link Test. at a length of 90 meters, cable attenuation, using 1 mw, should not exceed the dB loss table:

ATTENUATION

NEXT (worst Pair to Pair)

Frequency MHz	Loss dB
1.0	2.1
4.0	4.0
8.0	5.7
10.0	6.3
16.0	8.2
20.0	9.2
25.0	10.3
31.25	11.5
62.5	16.7
100.0	21.6

Frequency MHz	Loss dB
1.0	60.0
4.0	51.8
8.0	47.1
10.0	45.5
16.0	42.3
20.0	40.7
25.0	39.1
31.25	37.6
62.5	32.7
100.0	29.3

4.5 Data Multimode Fiber to the Station

4.5.1 Data Multimode Fiber Optic Cable:

Data fiber cable to the station is to be Corning cable with plenum jacket contain two 62.5/125 micron Multimode fibers.

4.5.2 Data Multimode Fiber Optic Cable Termination:

Terminations will be made with ST-type or SC-type connectors. In the communication closet connectors are to be terminated onto a fiber optic patch panel. The station end connectors are to be terminated onto an IO (information outlet). Fiber terminations are to be done with Corning, ST type or SC-type connectors.

4.5.3 Data Multimode Fiber Optic Cable Testing & Acceptance:

Unidirectional insertion loss (Power Meter) attenuation test; @ 850 nm. Each fiber shall not exceed 3.5 dB per km and must provide a minimum of 160 MHz of bandwidth per km @ 850 nm. Only a dB loss of 0.75 or less per connector or 1.5 dB per connector pair will be acceptable.

Test results are to be furnished to The University of Miami Department of Telecommunications in spread sheet form.

4.5.4 Tagging and Labeling

All Voice and Data cables shall be tagged and labeled within 6 inches of each end. Labeling must conform to the University of Miami labeling scheme.

JACK FIELD POSITION DEFINITION

POSITIONS: 1 - 5 Building Room Number

All rooms will be entered as five digits. This is to accommodate the room numbers at the Medical School where they use four numbers and an

alpha character. If a building uses a three digit numbering scheme then leading zeroes will be added to the room number.

6 A Period “.”

7 Jack Type Code

“V” - Voice

VOICE (V):

- The **first, second** and **third** position contain the jack number.
- The three digit number will be assigned to the jack by the technicians.
- Positions four, five and six currently not used.

Example: TR00235.V017
 TR: 00235
 Jack Type: V
 Jack Number: 17

DATA (D): Five digit alphanumeric code will be assigned to the jack by the technicians.

- The first digit will define the type of service being fed to the jack.
- The second digit will contain a letter designation assigned to the patch panel by the technician.
- The third and fourth two digit jack number.

Example: TR00235.D.A.94
 Room: 00235
 Jack Type: D
 Patch Panel #: A
 Jack Number: 94

Coax (TV): Five digit alphanumeric code will be assigned to the jack by the technicians.

- The first two digits will define the type of service being fed to the jack.
- The third, fourth and fifth digit is the three digit jack number.

Example: TR00235.TV.094
 Room: 00235
 Jack Type: TV
 Jack Number: 094

Proper labeling is required on Information Outlets (Jacks), Voice termination blocks and Data termination hardware.

Any non-compliant cables and hardware will be replaced at no cost to the University of Miami.

4.6 As Built Drawings

- 4.6.1** As Built drawings in the file format of Visio will be provided showing each cable run, origination point, termination point as well cable identification information.

5. FIRE-STOPPING

5.1 Riser Cables

All riser cables are required to be fire stopped using mineral or ceramic fiber and fire clay or putty. A cementitious material may also be used.

5.2 Entrance Cable

All entrance cables are required to be fire stopped using mineral or ceramic fiber and fire clay or putty. A cementitious material may also be used.

5.3 Firewall Penetrations

All firewall penetrations must be done in accordance with practices as not to violate the rating of the wall.

5.4 Material and Installation

All Fire-stop material must be UL classified, and installed in compliance with NEC, NFPA and any applicable building codes.

DIVISION 28 ELECTRONIC SAFETY AND SECURITY

This chapter identifies criteria for the design of electronic safety and security systems in University of Miami (UM) buildings with the purpose of establishing minimum standards, acceptable to UM, to be used as the basis of design for UM Coral Gables Campus buildings.

- 28.1 General Requirements
 - 28.1.1 Submittals
 - 28.1.2 Workmanship requirements
- 28.2 Codes and Standards
- 28.3 Design Criteria
- 28.4 Specific requirements (organized by CSI Master Format® 2012 Numbers & Titles)

28.1 General Requirements

“Electronic Safety and Security” systems/products must be selected to provide a safe, secure and controlled campus environment to all students, employees and users of the University of Miami facilities in a manner that strives to enhance safety by applying the principles of “Crime Prevention Through Environmental Design (CPTED) as well as the use of technology for access control, surveillance lance and intrusion detection where appropriate.

UMBS Coral Gables Campus and UM buildings electronic safety and security systems/products must be designed to comply with the following objectives for both renovations and new facilities:

1. Sustainable Design (Reduction of total building energy consumption).
2. Users ease and comfort.
3. Ease of maintenance.
4. Solutions with the best value considering a life cycle cost analysis to account for total project cost.

The design of the electronic safety and security systems/products, in concert with other building components, shall produce a building that meets the programmed sustainability rating (LEED rating) of the specific project, when applicable and possible under the proposed design solution.

At the University’s discretion: before start of construction on new buildings and/ or major renovations, Contractor shall provide a drawing for each building floor level showing coordination of all structural, architectural and MEP items. This includes but is not limited to: Structural members, floor plates, architectural ceilings, soffits, smoke barriers, fire walls, vertical shafts, sleeves, fire dampers, HVAC ductwork and equipment, plumbing piping and equipment, fire protection piping and equipment, alarm systems, communications, electrical distribution and equipment, lighting, controls, BMS, lighting protection, security systems, etc.

28.1.1 Submittals

Submittals shall include product data, samples, and shop drawings which are coordinated with all corresponding disciplines.

28.1.2 Workmanship requirements

Refer to specific requirements under each section included herein.

28.2 Codes and Standards

Electronic Safety and Security systems/ products shall comply with the requirements of the applicable authorities having jurisdiction including but not limited to the following:

1. Florida Building Code 2014
2. National Electrical Code (NEC)-2008 (NFPA 70).
3. Florida Fire prevention Code (FFPC)-2010
4. City of Coral Gables Building Code and Ordinances.
5. Standards included under each section.

28.3 Design Criteria

Refer to specific requirements under each section included herein.

28.4 Specific requirements (organized by CSI Master Format® 2012 Numbers & Titles)

28 16 00	Intrusion Detection and Access Control
28 23 00	Video Surveillance
28 31 11	Digital Addressable Fire Alarm System
28 35 00	Refrigerant Detection and Alarm

28 16 00 Intrusion Detection

Design Standards

1. The intent of these standards is to provide general guidelines for the design and provisions for electronic safety and security components of the site and building scope. These standards shall not supersede the prevailing codes and regulations, nor relieve the Architects from their professional responsibility.
2. Reference and coordinate the design effort with the requirements of the Campus Crime Prevention Working Group (CCPWG). All projects shall incorporate the prescribed access control, surveillance, intrusion detection and physical security and other environmental requirements.
3. Low voltage security and fire alarm systems are in this division due to the special expertise and coordination required for proper installation and full operation of systems.

4. The intrusion detection and access control system shall be design to include card readers at entrance doors, electric hardware and monitoring at each door, microprocessor based intelligent controllers, dual reader controller wiring between controllers in building, and software, hardware and firmware for the microprocessor based controllers and the host computer.
5. The requirements for intrusion detection and access control shall be included in the project's program statement. After consulting the building's occupants, University Police (UMPD), and Facilities Management Design & Construction Department, the requirements shall be refined during the project's design phase. In order to completely integrate this system into a construction project, the details shall be developed for inclusion to the design review.
6. All intrusion detection and access control hardware, firmware, and software furnished shall be the manufacturer's latest revision or product version, at the time of final acceptance.
7. All intrusion detection and access control components, material and equipment shall be new and unused.
8. All intrusion detection and access control components, material and equipment shall comply with local and state building code provisions.
9. Any device activated during non-standard operating hours shall alert UMPD unless otherwise discussed and documents by Facilities Management Design & Construction Department.
10. Specifications shall include the programming and interface to UM that is to be performed by the Contractors.
11. All points of entry from the exterior shall incorporate electronic intrusion and access control systems integrated with either new or existing university systems and shall provide instant remote lock-down by the UMPD communication center when necessary.

Product Standards

1. Specifications for recommended products and systems shall be provided by a single manufacturer, with the ability to interface with existing or future equipment as necessary and required.

Quality Assurance

1. Installer Qualifications:
 - a. The Contractor shall use personnel who are manufacturer-certified, thoroughly trained and experienced with the specific requirements and methods needed for the proper performance of the work.

2. Manufacturer Qualifications:
 - a. Manufacturer must have completed a minimum of 5 projects of a scope equal to the systems described herein. The manufacturer shall have a minimum of 5 years' experience supplying and installing specified type of systems.
3. Fabricator Qualifications Mock-ups:
 - a. Fabricator must have completed a minimum of 5 projects of a scope equal to the systems described herein. The fabricator shall have a minimum of 5 years' experience supplying and installing specified type of systems.

Warranty Requirements:

1. All materials furnished shall be free from defects of materials for a period of one (1) year excluding specific items of work that require a warranty of a greater period that may be set forth in the specifications. Contractor shall warrant workmanship for a period of one (1) year from date of substantial completion, excluding specific items of work that require a warranty of a greater period that may be set forth in this specification. Immediately upon receipt or written notice from the owner, the Contractor shall repair or replace at no expense to the owner, any defective material or work that may be discovered before final acceptance of work or within the warranty period; any material or work damaged thereby; and adjacent material or work that may be displaced in repair or replacement. Examination of or failure to examine work by the owner shall not relieve Contractor from these obligations.

Performance Standards-Minimum for Intrusion Detection Systems

1. Intrusion Detection System.
 - a. A (UL) listed intrusion detection control panels, extended zone modules and supervised remote power supplies as required.
 - b. All components must be shown on the construction documents.
 - c. The intrusion alarm system shall be zoned to annunciate the location within the complex initiating the signal.
 - d. Any device activated during non-standard operating hours shall alert UMPD unless otherwise discussed and documents by Facilities Management Design & Construction Department.
 - e. In addition to standard functions, include the capability in the intrusion detection system to bypass any zone or use time delay operations.
 - f. Specify the programming and interface to Facilities Management Design & Construction shall be performed by the Contractor.
 - g. Door Contacts:
 - 1) Provide door contacts and related devices at exterior doors, roof scuttles and interior doors to high security spaces including but not limited to student records, audiovisual equipment, instructional media equipment, computer equipment, chemical storage, facility operations and management equipment and other similar valuables or necessary spaces as identified by the Facilities Management Design & Construction and UMPD.

- 2) Rooms with both interior corridor access and motion detectors do not require interior door contacts.
- h. Motion Detectors
- 1) At ground floor and other spaces at floors with potential access from adjacent roofs, covered walkways or overhangs, provide motion detectors in each area or space with windows, fixed glass, or glass block to the exterior and at any room with vision panels.
 - 2) Provide motion detectors at enclosed stairway towers at all floors above the ground floor to protect the egress doors to the stairs.
 - 3) Provide motion detectors at exterior accessed storage rooms.
 - 4) Provide individual zones for each motion detector.
 - 5) Motion detectors shall have dual technology (PIR/ microwave).
- i. The system shall provide for the separate partitioning of dining, cafeterias, food service areas, auditoriums, gymnasiums/ locker rooms, media centers, library, administration areas, music rooms, theatre, and any other areas according to program requirements. A building may have multiple partitions but one partition should not include multiple buildings.
- j. A maximum of 4 associated doors switches may be grouped in one zone. Provide independent wiring for each switch from a junction box located next to the expansion zone module (EZM) before converting to a zone.
- k. Next to each card reader of a card reader access control system and inside the partitioned location, provide an intrusion detection keypad within 5'-0" of the entrance door.
2. Card Access Control System:
- a. Provide a microprocessor card access control system in new construction and designated renovation projects to monitor and control access to specific areas requiring secured access. UMPD will review and approve card reader locations during project initiation portion of the project with the Facilities Management Design & Construction Department.
 - b. Card Access controls systems shall be separate and independent from intrusion detection systems and fire alarms. The system shall be an internet-based control system, connected to UMPD main security control center
 - c. The design shall include a necessary component to provide a complete functional operable system that includes but is not limited to wiring, for power and control to sensors, card access controls, locks and other door hardware items or devices, uninterruptable power supply system (UPS) and capable of interfacing with existing AMAG software for a complete operable and fully integrated system capable of control through the internet
 - d. Raceway systems shall consist of conduit, J-hooks, sleeves, boxes and wiring for an automatic card access system.
 - e. Card Access Controls shall include the following:
 - 1) A proximity card reader installed adjacent to the exterior entrance of the program required areas for the identification of the authorized personnel.

- Verify an intrusion detection key pad is within 5'-0" of the entrance door and within the partitioned location.
- 2) Magnetic strikes as specified in finish hardware specifications. Mag locks shall be framed mounted. Provide signal switch in exit device and a motion or proximity sensor to release mag lock. Door strikes shall be normally closed type.
 - 3) The main cabinet shall be surface mounted steel construction, connected to existing software at the UMPD Security Command Center, installed on a plywood backboard. Main cabinet shall be installed in the MDF room, including all required power supplies, batteries, integral charger and the software for a complete fully operational system.
 - 4) Capability to control two access controlled doors with hardware and software to accomplish the following within a distance of 500 feet from the controller:
 - a) Two card readers
 - b) Two latch position switches
 - c) Two electric strikes
 - d) Two door position switches
 - e) Two sets of panic hardware
 - 5) The unit shall have the following electrical characteristics:
 - a) Normal 120 volt A.C. power supply; 2. 12 volt batteries for two hours of standby operation. 3. 12 volt D.C. fused at one amp, for control of electric strikes.
 - b) If a separate 120 V feed is needed at any device, a separate conduit will be needed.
 - 6) The system shall operate and allow controlled card access without connection to the host computer. It shall have a memory capacity to handle 2000 cards in this non communicating mode of operation.
 - 7) Modems shall be furnished and installed to connect the intelligent controllers to the host computer when the total wire distance between units is over 4000 feet. Two modems shall be furnished and installed: one at the intelligent controller; and one at the host computer site.
 - 8) Modems shall be furnished as part of the hardware/software/firmware package to insure system compatibility.
- f. Backboard: plywood, ½" thick, AC grade, covered with two coats of UL classified fire retardant intumescent paint, light gray color, painted front, rear and four sides.
- 1) Backboard shall be clearly labeled with the name of the backboard manufacturer, UL Classification of the fire retardant coating with NFPA 255 coating flame index and the APA grade of the plywood. Backboard shall be securely fastened to wall in order to support any and all attached equipment.
- g. Security System Boxes:
- 1) Individual outlet boxes shall consist of a standard 2" x 4" x 2-1/8" inch square outlet box with appropriate single gang mud rings and weatherproof covers where required in walls. Mounting height shall be as indicated on drawings.
 - 2) Cover plates: The contractor shall provide a blank weatherproof stainless steel cover plate for all outlet boxes.

- h. Pull String:
 - 1) A nylon pull string shall be installed in all future or empty conduits installed for the card access control system.

- i. Raceway:
 - 1) Raceway shall be EMT and shall be sized as shown on the contract documents. Minimum size of conduit shall be 1". Use only compression couplings designed specifically for the type of conduit or raceway utilized. Use 1/2 inch minimum flexible metallic conduit when running conduit in door frames. Provide insulated bushings at conduit termination.
 - 2) Install interior raceway system with maximum of 270 degrees of total bends, or 150 feet of total distance, between outlets or junction boxes. Raceways for the card access system shall not share raceways or cable trays with other systems such as power, telecommunications, and fire alarm. Or department operated network systems.
 - 3) Install conduit at the location shown on the drawings. Where plywood backboard is shown, stub conduit up to a level two inches above bottom of backboard and secure to backboard.
 - 4) Extend raceway from each security wall outlet directly to the serving Diebold 1000 card access controller.
 - 5) All security conduits shall be concealed and all boxes flush mounted.
 - 6) See contract documents and shop drawings for mounting heights of devices and equipment. This contractor shall be assigned the responsibility to coordinate the mounting heights and details of the components of the card access system. No surface mounted raceways shall be allowed unless specifically defined in the contract documents.

- j. Conduit Sizing:
 - 1) Conduit sizes shall be as shown on the drawings, however, all conduit sizes shall be verified with the Architect/Engineer before rough in for proper size.

- k. Boxes:
 - 1) Install one box for each security outlet and junction point. All Boxes shall be flush mounted. This contractor shall be assigned the responsibility to coordinate the mounting heights and details of the components of the card access system. No surface mounted boxes shall be allowed unless specifically defined in the contract documents.

- l. Equipment Mounting and Location:
 - 1) The card access controller shall be mounted in electrical closets as indicated on the contract documents. All mounting locations shall be readily accessible and within locked spaces. Mounting above ceilings and other inaccessible spaces shall not be allowed.
 - 2) Control and other panels shall be mounted with sufficient clearance for observation and testing. All security system junction boxes shall be clearly marked. All wiring shall be in conduit.

- m. Card Access Controller Firmware:
 - 1) Furnish all firmware necessary for a complete and fully functioning system, including firmware for complete communication with the Host computer.

- n. Host Computer Software:

- 1) Provide all software necessary for configuring this new system to the University of Miami existing system for complete and fully functioning system.
- o. Card Readers:
 - 1) Card readers shall be furnished and installed by the contractor. The exact quantity and type shall be determined during the project's preliminary design phase. The final configuration for card readers shall be determined after consultation with the occupying department, University Police, and Facilities Management.
 - 2) Do not install card readers in the direct path of egress. Install in a secured location, i.e. electrical closet, as approved by the University.
- p. Wiring:
 - 1) All wiring shall be shielded per manufacturer direction, checked and testing to insure that there are no grounds, opens, or shorts.
 - 2) No wiring other than that directly associated with card access system or its auxiliary functions shall be in card access system conduits. Wiring splices shall be avoided to the extent possible, and if needed they shall be made only in junction boxes, and enclosed by plastic wire nut type connectors. Transposing or changing color coding of wires shall not be permitted. All conductors in conduit containing more than one wire shall be labeled on each end, in all junction boxes, and at each device with "E-Z Markers" or equivalent. Conductors in cabinets shall be carefully formed and harnessed so that each drops off directly opposite to its terminal. Cabinet terminals shall be numbered and coded, and no undetermined conductors are permitted in cabinets or control panels. All controls, function switches, etc., shall be clearly labeled on all equipment panels.
 - 3) Provide, as required, audible suppression devices for interference-free and properly operational system and that both audible and multiplex wiring be run in same raceway.
 - 4) Raceway shall not exceed 400'-0" without a pull box.
 - 5) A 2" raceway from the main cabinet to the next building & floor distribution cabinet shall be used.
- q. Final Test
 - 1) Tests:
 - a) The contractor shall perform all electrical, software, hardware, and mechanical tests required by the equipment manufacturer's standard check out procedure.
 - b) The system final test shall be conducted under the direction of a technician certified by the manufacturer.
 - 2) Required Submissions:
 - a) At the time the system is tested, the Contractor shall supply the following items to the University of Miami before the test is started:
 - b) Drawings showing the floor plan of the building, all device locations, and device addresses, Card Access Controller locations, wiring between the units, and the location of the modem.

- r. Scheduling and Sequencing of Tests:
- 1) Final testing of the system shall not occur until the entire system is 100% complete and fully functioning. In the event that phased construction schedules require partial system operation, portions of the system may be tested. However, the entire system must be operating and fully functional before final testing; final acceptance and substantial completion shall be allowed to occur.
 - 2) The final test shall be scheduled so that it may be witnessed by the Architect/Engineer and Facilities Management Design & Construction personnel. This shall require notifying the above referenced groups, in writing, a minimum of seven working days in advance of the final test.
- s. Final Report Contents:
- 1) The report shall include:
 - a) A complete list of installed and wired equipment.
 - b) Indication and demonstration that all equipment is properly installed and functions and conforms to these specifications.
 - c) Tests of each individual device.
 - d) Voltage and current settings for each device while in operation or in each state (such as open or closed).
 - e) Demonstration of communication, alarm transmission, monitoring, and remote programming of the local units from the Host Computer.
 - f) Technician's name, address, telephone, FAX, ID Number, and date.
 - 2) After completion of all the tests and adjustments listed above, the contractor shall submit the following information to the architect and the Facilities Management Design & Construction:
 - a) "As-built" conduit layout diagrams including wire color code and/or tag number.
 - b) Complete "as-built" wiring diagrams.
 - c) Detailed catalog data on all installed system components.
 - d) Copy of the final test report.
 - e) Drawings showing the floor plan of the building, device locations, and device addresses.
 - 3) Final tests and inspection shall be held in the presence of Architect, University Project Management and Facilities Management Representative and conducted to their satisfaction. The contractor shall supply personnel and required auxiliary equipment for this test without additional cost. Any problems identified during system testing must be corrected by reprogramming or other corrective work. After the reprogramming or other work is complete, the Contractor shall submit corrected documentation to the University.
 - 4) The completed access control system shall be demonstrated to insure its proper operation. This demonstration shall consist of activating the installed system and all its features. The card access system shall be demonstrated with a several cards. All door monitoring functions shall also be demonstrated. The test shall include the observation of all host software functions and their accurate reporting of the field conditions. The test must

include accessing the system software in the existing Host Computer. The contractor shall furnish all system passwords, communication software, and system software to demonstrate. The software and passwords shall remain with the University for use in the continuing operation and maintenance of the system.

- t. Final Acceptance:
 - 1) Final Acceptance of the system shall also require a demonstration of the stability of the system. This shall be adequately demonstrated if the system operates for a 90-day test period without any unwarranted or false alarms. Should an unwarranted or false alarm occur, the contractor shall readjust or replace the faulty component and begin another 90-day test period. As required by the Architect/Engineer, the contractor shall recheck and retest the replaced components after each readjustment or replacement. This test shall not start until the owner has obtained beneficial use of the building under test.
 - 2) Before final acceptance of work, the contractor shall deliver five copies of a composite "Operating and Shop Maintenance Manual". Each manual shall contain a statement of guarantee including date of termination and name and phone number of the person to be called in the event of equipment failure, including individual factory issued manuals containing all technical information on each piece of equipment installed. In the event such manuals are not obtainable from the factory it shall be the responsibility of the contractor to compile and include them. Advertising brochures or operational instructions shall not be used in lieu of the required technical manuals.
- u. Training:
 - 1) Training shall be included in the testing phase of the system installation. The manufacturer's technician shall instruct the University personnel in all aspects of the system. The manufacturer's technician shall be available to answer all questions and provide explanations as requested by the University personnel.
 - 2) Provide three (3), three-hour training sessions, with one session per day for three consecutive days, for campus Electrical Department personnel. Also, provide one four-hour session of training in operation and maintenance. Training times indicated are actual times exclusive of travel.

28 23 00 Video Surveillance

Design Standards

1. The intent of these standards is to provide general guidelines for the design and provisions for video surveillance security components of the site and building scope. These standards shall not supersede the prevailing codes and regulations, nor relieve the Architects from their professional responsibility.

2. Reference and coordinate the design effort with the requirements of the Campus Crime Prevention Working Group (CCPWG). All projects shall incorporate the prescribed surveillance and other environmental requirements to the facility.
3. The requirements for intrusion detection will be included in the project's program statement. Upon consultation with the building's occupants, University Police (UMPD), and Facilities Management Design & Construction Department, the requirements shall be refined during the project's design phase. In order to completely integrate this system into a construction project the details shall be developed for inclusion to the design review.
4. All video surveillance hardware, firmware, and software furnished shall be the manufacturer's latest revision or product version, at the time of final acceptance.
5. All video surveillance components, material and equipment shall be new and unused.
6. All video surveillance components, material and equipment shall comply with local and state building code provisions.
7. Any device activated during non-standard operating hours shall alert UMPD unless otherwise discussed and documents by Facilities Management Design & Construction Department.
8. Specifications shall include the programming and interface to UM that are to be performed by the Contractors.
9. All points of entry from the exterior shall incorporate electronic intrusion and access control systems integrated with either new or existing university systems and shall provide instant remote lock-down by the UMPD communication center when necessary.

Product Standards

Specifications for recommended products and systems shall be provided by a single manufacturer, with the ability to interface with existing or future equipment as necessary and required.

Quality Assurance

1. Installer Qualifications:
 - a. The Contractor shall use personnel who are manufacturer-certified, thoroughly trained and experienced with the specific requirements and methods needed for the proper performance of the work.
2. Manufacturer Qualifications:
 - a. Manufacturer must have completed a minimum of 5 projects of a scope equal to the systems described herein. The manufacturer shall have a minimum of 5 years' experience supplying and installing specified type of systems.

3. Fabricator Qualifications Mock-ups:
 - a. Fabricator must have completed a minimum of 5 projects of a scope equal to the systems described herein. The fabricator shall have a minimum of 5 years' experience supplying and installing specified type of systems.

Warranty Requirements:

1. Contractor shall warrant that all materials furnished shall be free from defects of materials for a period of one (1) year excluding specific items of work that require a warranty of a greater period that may be set forth in the specifications. Contractor shall warrant workmanship for a period of one (1) year from date of substantial completion, excluding specific items of work that require a warranty of a greater period that may be set forth in this specification. Immediately upon receipt or written notice from the owner, the Contractor shall repair or replace at no expense to the owner, any defective material or work that may be discovered before final acceptance of work or within the warranty period; any material or work damaged thereby; and adjacent material or work that may be displaced in repair or replacement. Examination of or failure to examine work by the owner shall not relieve Contractor from these obligations.

Performance Standards-Minimum

Video Surveillance Cameras and Systems:

1. Surveillance Cameras:
 - a. Cameras shall have a minimum of at least 480 line of resolution.
 - b. Cameras shall be high resolution color, daylight night mini domes cameras.
 - c. Cameras shall be equipped with lenses that have an automatic iris and variable focal length of 4 to 8 millimeters.
 - d. Cameras housing shall be vandal resistant.
 - e. Camera domes shall be clear.
 - f. Exterior mounted cameras shall be pendant mounted.
 - g. Exterior cameras shall include integral infrared illumination consistent with desired field of view.
2. The Contractor shall provide, install, and program a functionally complete video surveillance system per Manufacturer's guidelines, codes, described, and the University of Miami Building Standards.
3. Security contractor scope of work shall include swing-over of all existing analog cameras and specified HDVR programming. This includes programming any PTZ cameras that are connected and programming new HDVR per specifications.
4. System Wiring:
 - a. All system wiring shall be plenum rated.
 - b. Video transmission cable shall be plenum rated CAT6 or greater for all camera runs up to 100 meters. Lengths exceeding 100 meters will require an Ethernet extender or other transmission formats such as UTP (Unshielded Twisted Pair) wire, IP, or fiber-optic cable with encoders and decoders as required.
 - c. Wire gauge and shielding shall follow the manufacturer's installation guidelines.

- d. All wiring shall be installed in accordance with the National Electric Code (NEC) and the National Fire Protection Agency (NFPA).
 - e. Verify all terminations at HDVR as well as at cameras.
 - f. Cables penetrating floors and firewalls must be routed through a metallic sleeve and properly fire stopped to meet national and local fire codes. All walls and floors shall maintain their existing fire rating.
 - g. The Contractor shall adjust cameras (aim and focus) and verify with UMPD that the field of view and line of sight is acceptable.
 - h. The Contractor shall not data lock any security equipment to prevent University personnel or any university authorized vendor from editing or revising program.
 - i. Surveillance cameras shall be wired from the device back to the video recording equipment located in the nearest IDF.
 - j. Design Selection: Cable shall be RG-6U composite coaxial with 18/2 for runs greater than 1000'-0" (Belden 539945 or 639948 plenum rated or approved equal); RG 59U composite coaxial with 18/2 for shorter runs less than 1000'-0" (Belden 549946 or 649948 plenum rated or approved equal) with ten (10) feet slack at each end. Cameras mounted on poles for parking areas or site surveillance are to be serviced by fiber optic cable with am 18/2 for power (cable will be sized for distance).
4. Recommended Manufacturer's for video Surveillance cameras:
- a. Bosch
 - b. American Dynamics
 - c. Arecont
 - d. Panasonic
 - e. Pelco
 - f. Axis
- Any substitutions shall be submitted to UMBS Committee for approval.
5. Additional Equipment
- a. HP Pro Curve POE 24-Port Ethernet Switch;
 - b. CAT6 cable from video recorders to SecLAN switch.
 - c. 120 VAC N/E electric power for NVR and Ethernet Switch.
6. Video Surveillance Scope/Equipment Location/Unit Specification
See Scope and Drawings
7. Hybrid Network Video Recorder (HDVR)
- a. The HDVR server shall have recording resolutions of CIF, 2CIF, and D1 and shall be user selectable for each individual analog camera attached to the server. Standard resolution and high resolution mega-pixel IP cameras shall also be selectable. H.264 or MJPEG video compression format shall be user selectable on any analog camera. Video recording shall be available at up to 30 images per second per input channel depending on IP camera type and server model selected.

- b. The Hybrid Digital Video Recorder (HDVR) shall have Video Surveillance Management System (VSMS) software for viewing live and recorded video from analog and IP cameras and video encoders connected to a local and wide area network. The VSMS software shall have a Client-Server based architecture that can be configured as a standalone VSMS system with the Client software running on the server hardware and/or the Client running on any network connected TCP/IP PC workstation. Multiple client workstations shall be capable of simultaneously viewing live and/or recorded video from a single or multiple servers. Multiple servers shall also be able to simultaneously provide live and/or recorded video to a single or multiple workstation(s). Included in the cost of the software are an unlimited number of client software applications.
 - c. The VSMS software running on the HDVR shall have an open architecture supporting IP cameras and encoders from multiple manufacturers providing best of breed solutions from low-cost entry-level features to high resolution megapixel features. A minimum of five (5) IP camera manufacturers must be supported from leading companies such as Bosch, ACTi, Arecont Vision, Axis, IQinvision, Panasonic, Sony and Vivotek.
8. HDVR programming
 - a. System Name: Shall be the abbreviated building name (followed by a number, if multiple DVRs are in the building)
 - b. Time server shall be synched to University of Miami Time Server (clock.psu.edu or 128.118.25.3)
 - c. Network Settings: When available in building, HDVR shall be connected to the SecLAN network. IP address will need to be obtained through A.C.E.S.
 - d. Camera setup and recording camera resolutions shall vary depending on the cameras selected and added to the HDVR server. Cameras shall be set to record and live stream at full resolution. Frame rates shall be set for 1 fps normal, 10 fps on alarm. Alarm parameters shall be set to mask motions other than intended targets. A.C.E.S. will determine which cameras are intended for facial recognition and general area surveillance. A.C.E.S. shall provide camera names. All cameras must be named prior to placing system into operation.
9. Programming of the system shall include the following tasks:
 - a. Programming system configuration parameters (hardware and software, camera location/number, communication parameters);
10. Other programming tasks required by the Owner. These additional programming requirements shall be coordinated between the Owner and the Contractor.
11. Testing
 - a. Operational Testing: The contractor shall perform thorough operational testing and verify that all system components are fully operational.
 - b. Hard-copy System Printout: The contractor shall submit a hard-copy system printout of all components tested and certify 100 percent operation indicating all devices / panels / units have passed the test criteria set forth by the manufacturer.
 - c. Acceptance Test Plan Form: An acceptance test plan form shall be prepared /

provided by the contractor prior to the acceptance walk through. This form shall include separate sections for each device/panel/unit as well as a column indicating the manufacturer's performance allowance/margin, a column indicating the result of the testing performed by the contractor (pass/fail), and an empty column for recording findings during the walk-through.

12. **Commissioning**
The Contractor shall certify completion in writing and schedule the commissioning walk-through. The contractor shall provide all of the tools and personal needed to conduct an efficient commissioning process.
13. **Training**
The Contractor shall provide up to 16 hours of on-site training shall be provided which shall include training on the proper installation and programming of all related hardware and software and training of departmental end-user.
14. **Field Quality Control**

28 31 11 Addressable Fire Alarm Detection System

Design Standards

1. The intent of these standards is to provide general guidelines and specifications for an Addressable Fire Alarm Detection System at University of Miami. It is not intended to be an all-inclusive specification in and of itself, in that; it is supplemental to other specifying tools such as Masterspec. It is also not the intent of this Design Criteria to supersede other regulations contained in federal, state and local codes.
2. The purpose of this Design Criteria is two-fold:
 - a. Identify an acceptable quality of Addressable Fire Alarm Detection System for use in University of Miami facilities.
 - b. Establish a minimum of three (3) acceptable manufacturers of that quality level in order to inspire competition.
3. The work described herein and on the drawings consists of all labor, materials, equipment, and services necessary and required to provide and test automatic fire detection and alarm system. Any material not specifically mentioned in this specification or not shown on the drawings but required for proper performance and operation shall be provided.
4. Drawings and specifications herein are to comply to the best of the engineer's knowledge with all applicable codes at the time of design. However, it is this contractor's responsibility to coordinate/verify (prior to bid) the requirements of the authority having jurisdiction over this project and bring any discrepancies to the engineer's attention at least seven (7) days prior to bid. No changes in contract cost will be acceptable, after the bid, for work and/or equipment required to comply with the authority having jurisdiction.

5. Advised that circuit routing for this system is not necessarily shown on the project drawings. Provide and install all raceways, wiring and cabling required for a complete and fully functional system as intended by these specifications. All wiring and/or cabling shall be in conduit. Provide and install a properly sized, flush mounted outlet box for every device. Raceways are to be sized and routed to accommodate the proper installation of the system cabling. T-Tapped cabling shall not be acceptable. In locations where raceway and/or conduit is not accessible after completion of the project, conduit shall be routed from device to device or fire rated access panels shall be installed to provide access to junction and pull boxes. Routing of raceway from device to device shall only be acceptable where the wiring scheme of the system, as recommended by the manufacturer, requires cable to pass from device to device. Properly terminate each device according to the manufacturer's recommendations. Provide and install firestopping where penetrations are made through rated walls and floors.
6. This Specification describes a fully addressable, common fire alarm system, with remote power supplies for various buildings and portables.
7. Provide and install the Fire Alarm system (including all equipment, wiring, etc.) in accordance with the Manufacturer's recommendations.
 - a. Installation of devices shall be in accordance with the Manufacturer's requirements as well as the requirements of the Contract Documents. Recommendations by the Manufacturer for the proper installation of the Fire Alarm system and its equipment shall not preclude the requirement for the Contractor to comply with the requirements of the Contract Documents.
 - b. Termination of Fire Alarm circuits shall be in accordance with the Manufacturer's recommendations, applicable requirements of the National Electric Code (NFPA 70), National Fire Alarm Code (NFPA 72), ADA, other applicable Codes and the Contract Documents.
 - c. Voice evacuation audio circuits (25 or 70V) shall be run in separate raceways from Fire Alarm data loops and other system circuits where the potential exists for interference or adverse effect upon the proper operation of the any Fire Alarm equipment, circuit or the system as a whole.
 - d. Fire Alarm Installer shall be responsible for ensuring that prior to bidding the project the Electrical Contractor understands the raceway requirements for the project. Claims by the Contractor after award of the project in regard to additional raceway required either by the Fire Alarm System Manufacturer's recommendations for proper installation of the system and its associated equipment, or for compliance with the requirements of the Contract Documents, shall not be allowed.
 - e. Contractor shall note that the drawings show Fire Alarm Remote Panels (FARP) in various locations. FARP's are intended to be equipment (remote control panels, power supplies, addressable modules, power, grounding, and any other equipment or materials) necessary for a remote extension of the Fire Alarm System. FARP's shall be connected to the campus FACP via a Signal Line Circuit (SLC) and other circuits specifically recommended by the Fire Alarm manufacturer and required to meet the intent of the project documents. An individual FARP shall provide the necessary circuitry (Notification Appliance Circuits (NAC), Initiating Device Circuits (IDC), DC power circuits required by various devices, etc.) to the

Fire Alarm devices within its coverage area. The FARP shall provide interconnection services between the device circuits in its area of coverage and the FACP just as if those device circuits were directly connected to the FACP.

Performance Standards

1. The Contractor shall furnish and install a complete Addressable Analog Fire Detection [System] or [Network]. The system shall include but not be limited to:
 - a. Main Fire Alarm Control Panel (FACP) including all required power supplies
 - b. Fire Alarm Annunciator Panel (FAAP)
 - c. Manual Pull Stations
 - d. Smoke Detectors
 - e. Duct Detectors
 - f. Heat Detectors
 - g. Combination Audible/Visual devices (indoor and outdoor weatherproof as indicated on the drawings)
 - h. Visual devices (indoor and outdoor weatherproof as indicated on the drawings)
 - i. Remote fire alarm control panels (Network Nodes)
 - j. Remote power supplies (Remote power supplies shall be in a UL Listed assembly and be provided by the same manufacturer as the Fire Alarm Control Panel (FACP)).
 - k. "Do not use elevator" warning lights.
 - l. UL Listed Communicator (DMP: iComSL).
 - m. "Areas of Rescue Assistance" Equipment (Areas of Rescue Assistance Equipment shall be provided and installed by the Fire Alarm System Installer).
 - n. Surge Suppression
 - o. Programming.
 - p. Grounding
 - q. Firestopping (See Division 7 Section)
 - r. Wire and cable labeling.
 - s. Electrical power required to comply with all functions and operations called for in this section of the specifications. Contractor shall provide and install all 120 VAC circuits as required.
 - t. Conduit, wire, wire fittings, terminal cabinets with plywood and terminal strips, and all accessories required to provide a complete operating system.
 - u. A complete and accurate schematic/drawing of the fire alarm system to be placed Adjacent to the fire alarm annunciator panel and the main fire alarm panel.

2. Furnish and install all equipment (raceways, wire/cable, circuit breakers, modules, relays, etc.) necessary, and as required by applicable code, to accomplish incidental functions of the fire alarm system including but not limited to the following:
 - a. Elevator recall, control, and/or shutdown.
 - b. Monitoring of Sprinkler System and/or Fire Protection System Flow and Tamper switches.
 - c. Monitoring of Sprinkler System and/or Fire Protection System Valve Supervisory switches.
 - d. Monitoring of Post Indicator Valve (PIV) switches.

- e. Gas/Fuel valve shut-off.
 - f. Escalator shutdown.
 - g. HVAC system control and/or shutdown.
 - h. Ventilation system (supply fans, exhaust fans, fan terminal boxes, etc.) control and/or shutdown.
 - i. Smoke Control system control and/or shutdown.
 - j. Control of fire, smoke, and/or combination fire/smoke dampers.
 - k. Fire suppression and or extinguishing systems.
 - l. Monitoring of kitchen hood fire suppression systems
 - m. Control of fire and/or smoke doors, dampers, shutters, etc.
 - n. Computer room power panels and air conditioning control and/or shutdown.
 - o. Control of door hold open devices.
 - p. Control of time out room door lock devices.
 - q. Connection to the internet via a local data drop.
3. System shall operate as a non-coded, continuous ringing system which will sound all audible devices and activate all visual devices until it is manually silenced.
 4. System shall be wired as a Class B system for all circuits.
 5. System is to be a complete analog addressable system except for portables. Portables shall be wired as hard-wired circuits.
 6. All portions of fire alarm system shall be installed in conduit; conduit and boxes shall be installed by electrical contractor.
 7. Fire alarm system shall not share a raceway, junction box, enclosure, manhole or device with any other system.
 8. Advise owner of requirements for monitoring the fire alarm system by owner's monitoring company and provide all electrical required for remote monitoring, including tie to security cabinet.
 9. Provide and install wiring, equipment, etc. for connection to devices furnished under other divisions of the work.
 10. Provide and install wiring, equipment, etc. as required to deactivate power in the elevator rooms by heat detectors via shunt trip breakers and arm sprinkler pre-action system.
 11. Provide and install wiring, equipment, etc. as required to deactivate power to computer power panels and air conditioning equipment by automatic or manual devices as shown on plans.
 12. In buildings, two or more floors not fully sprinkled, provide communication equipment, in accordance with all applicable codes, for Areas of Rescue Assistance.

13. Although they may not be indicated on the Fire Alarm system diagram and/or drawings, all required control and interlock wiring between the Fire Alarm system and building equipment shall be provided hereunder. Controls are required to/for/from:
 - a. Fire/smoke air and duct detectors
 - b. Fire, smoke and/or combination fire/smoke dampers.
 - c. Supply/Return fans, Exhaust fans, and/or Fan Terminal Boxes (FTB)
 - d. Automatic fire extinguishing systems
 - e. Smoke evacuation equipment
 - f. Sprinkler and/or Fire Protection system components
14. Provide wiring for Post Indicator Valve Alarms, in each instance in which these are provided under work of Other Trades, connected to Fire Alarm System.
15. Provide and install all relays (electric-electric, electric-pneumatic, and/or pneumatic-electric) as required for a complete and operational fire alarm system, complying with all applicable codes and all requirements, and coordinated with all divisions of these specifications.
16. Provide terminal cabinets sized to house terminal strips and surge suppression equipment.
17. Surge Suppression
 - a. The contractor shall have equipment installed on the AC voltage supply and other lines taking care to arrest damaging electrical transient and spikes which can cause damage to the microprocessor components of the system. Central office telephone lines shall have equipment installed to arrest high voltages from electrical and/or lightning from entering the system and causing damage.
 - b. Provide and install all materials, labor and auxiliaries required to furnish and install complete surge suppression for the protection of building fire alarm system from the effects of induced transient voltage surge and lightning discharge as indicated on drawings or specified in this section.
 - c. Provide surge suppression equipment at the following locations:
 - 1) On each conductor pair and cable sheath entering or leaving a building.
 - 2) On each conductor associated with fire protection (sprinkler) system fire alarm connections.
 - 3) On any and all telephone lines.
 - 4) In other locations where equipment sensitivity to surges and transients requires additional protection beyond that inherent to the design of the equipment. Where equipment being protected has internal surge suppression equipment, the surge protection equipment herein specified is required to be installed in addition to internal equipment protection.

Standards, Codes, References, and Regulatory Requirements

1. Equipment and installation shall comply with the current or applicable provisions of the following standards:
 - a. ANSI S3.41 American National Standard Audible Emergency Evacuation Signal
 - b. National Fire Protection Association Standards:

- 1) NFPA 70 National Electrical Code [NEC] (including but not limited to Article 760, Fire Alarm Systems, Article 770 and Article 800)
 - 2) NFPA 72 National Fire Alarm Code
 - 3) NFPA 101 Code for Safety to Life from Fire in Buildings and Structures
 - 4) NFPA 90A Installation of Air Conditioning and Ventilating Systems
 - 5) NFPA 96 Ventilation Control and Fire Protection of Commercial Cooking Operations
- c. Underwriters Laboratories Inc. System and all components shall be listed by Underwriters Laboratories Inc. for use in fire protective signaling system under the following standards as applicable:
- 1) UL 864 (Category UOJZ) APOU Control Units for Fire Protective Signaling Systems. All Control Equipment shall be listed under UL category UOJZ.
 - 2) UL 268 Smoke Detectors for Fire Protective Signaling Systems
 - 3) UL 268A Smoke Detectors for Duct Applications
 - 4) UL 217 Smoke Detectors Single Station
 - 5) UL 521 Heat Detectors for Fire Protective Signaling Systems
 - 6) UL 228 Door Holders for Fire Protective Signaling Systems
 - 7) UL 464 Audible Signaling Appliances
 - 8) UL 1638 Visual Signaling Appliances
 - 9) UL 1481 Power Supplies for Fire Protective Signaling Systems
 - 10) UL 1480 Speakers
 - 11) UL 1424 Cables
 - 12) UL 1971 Signaling Devices for the Hearing Impaired
 - 13) UL 1449 Standard for Safety, Transient Voltage Surge Suppressors.
 - 14) UL 497, UL 497A, UL 497B.
- d. All fire alarm equipment, including accessories to the system and including all wires and cable unless otherwise noted, shall be listed by the Underwriters' Laboratories product directory called Fire Protection Equipment and/or the Electrical Construction Materials List.
- e. Each item of the fire alarm system shall be listed and classified by UL and FM as suitable for purpose specified and indicated.
- f. System controls shall be UL listed for Power Limited Applications per NEC 760. All circuits must be marked in accordance with NEC article 760.
- g. All equipment supplied as part of the Fire Alarm System shall be provided by a single manufacturer and shall comprise a complete UL Listed Fire Alarm System.
- h. IEEE: Fire alarm system includes solid state electronic components. Therefore, the equipment manufacturer shall provide certification that all such equipment is internally protected from, or can withstand, power line surge voltages and currents as specified in Table 1, Location Category a High Exposure of ANSI/IEEE Standard C62.41-2002 (formerly IEEE Standard 587).
2. Equipment and installation shall comply with the current or applicable provisions of the following codes and laws:
- a. Americans with Disabilities Act (ADA): The fire alarm system shall comply with ADA, Public Law 101-336, 1990. The system shall comply with ADA Accessibility Guidelines (ADAAG).

- b. Federal Register - Rules and Regulations - Non-discrimination on the basis of Disability by Public Accommodations and in Commercial Facilities.
 - c. ASME/ANSI A17.1 - 1997 Elevator Code.
 - d. Local and State Building Codes.
 - 1) Florida Building Code: Latest adopted edition.
 - 2) Florida Administrative Code. All applicable chapters including but not limited to:
 - a) Chapter 4A Rules, including but not limited to:
 - Ch 4A-3 Fire Prevention - General Provisions.
 - Ch 4A-19 Fire Prevention - Garages.
 - Ch 4A-27 Fire Prevention - Places of Assembly.
 - Ch 4A-43 (Florida Handicap Code - Lodging)
 - Ch 4A-46 Fire Protection System Contractors and Systems.
 - Ch 4A-47 Uniform Fire Safety Standards for Elevators.
 - Ch 4A-48 Fire Safety Standards for the Fire Alarm Systems.
 - b) Florida Administrative Code 10A-12 (Florida Handicap Code - Hospice)
 - 3) Florida Fire Prevention Code
 - 4) Florida Department of Insurance:
 - a) Insurance Code: The fire alarm system and installation thereof shall comply with the State of Florida Department of Insurance rules. The requirements of the Florida State Department of Insurance shall be as promulgated by the Division of State Fire Marshal.
 - b) Fire Alarm Rules: The fire alarm system and installation thereof shall comply with the Fire Safety Rules promulgated by the Florida State Fire Marshal.
 - 5) Authority Having Jurisdiction:
 - a) General: The system shall comply with all applicable Codes, Ordinances and Standards as interpreted and enforced by the local authority having jurisdiction.
 - b) Fire Department: City of Coral Gables Fire Department
 - c) Building Official: City of Coral Gables Building Department
 - d) State of Florida: Division of State Fire Marshal.
3. Surge Suppression:
- a. Equipment Certification: When available by any one manufacturer, all surge suppression equipment shall be listed by Underwriters' Laboratories, shall bear the UL seal and be marked in accordance with referenced standard. Such surge suppression equipment shall be UL listed and labeled for intended use.
 - b. Comply with all standards and guides as listed under "References" above.

Related Sections

- 1. All applicable sections of Division 0, Division 1, and Division 16.

2. Applicable sections of these specifications with regard to, but not limited to:
 - a. Doors
 - b. Exhaust hoods
 - c. Elevators
 - d. Standpipe and fire hose systems
 - e. Sprinkler systems
 - f. Extinguishing systems
 - g. Ductwork accessories: smoke dampers
 - h. Building control systems
 - i. Theatrical lighting systems
 - j. School intercom system with time program clock
 - k. Local area sound system
 - l. Intrusions detection system(Note: Engineer shall provide above specification if required by scope of work.)

Quality Assurance

1. Manufacturer: Company specializing in manufacturing the products specified in this section with minimum ten (10) years' experience and with service facilities within 50 miles of Project.
2. Installer:
 - a. Company specializing in installing the products specified in this section with minimum ten (10) years' experience.
 - b. The Installer shall be currently licensed by the Electrical Contractors' Licensing Board as a Certified Alarm System Contractor I (EF).
 - c. The installing Contractor shall be a direct sales division of, or the authorized and designated distributor for, a fire alarm system manufacturer.
 - d. Installing Contractor shall maintain a local staff of specialists, including a Fire Alarm Planning Superintendent, for planning, installation, and service.
 - e. The installing Contractor shall maintain an office within fifty (50) miles of the project with capability to provide emergency service 7-days-a-week, 24 hour days. The installing Contractor shall have been actively engaged in the business of selling, installing and servicing fire alarm systems for at least ten (10) consecutive years going back from date of bid.
3. Surge Suppression
 - a. All surge suppression devices shall be manufactured by a company normally engaged in the design, development, and manufacture of such devices for electronics/communications systems equipment.
 - b. The surge suppressor manufacturer shall offer technical assistance through support by a factory representative and local stocking distributor.
 - c. Verify proper clearances, space, etc. is available for surge suppressor.
4. Coordination/Project Conditions
 - a. Verify proper grounding is in place.

- b. In installations where the electrical contractor does not provide a counterpoise system in conjunction with the underground raceway system, the fire alarm contractor shall provide a coupling conductor within the fire alarm underground raceway system to run alongside fire alarm conductors. Coupling conductors shall be sized according to applicable codes and standards.
5. To establish the type and operating characteristics of the fire alarm system, the equipment specified herein is used as a guide in determining the functions of the fire alarm system. Other equipment will be considered for approval provided the following is submitted in writing by the system installer to the engineer (See Section 16010 on Substitutions):
 - a. Contractor qualifications (as listed above).
 - b. Complete lists, descriptions and drawings of materials to be used.
 - c. A complete drawing showing conduit, conduit sizes, back boxes, number of wires and wire sizes.
 - d. A complete riser diagram of Fire Alarm System.
6. Acceptable Manufacturers:
 - a. Basis of Design
 - 1) Edwards Systems Technology EST-3
 - b. Acceptable Substitution:
 - 1) Notifier
 - 2) Fire Control Instruments, Inc.

Submittals

1. Submit in accordance with Division 01 Section and 20 02 00 and 26 05 05.
 - a. Narrative of operation of System as provided. (Submittal will not be reviewed by the A/E without this narrative.)
 - b. Manufacturer's data on all products, including but not limited to:
 - 1) Catalog cut sheets.
 - 2) Roughing-in diagrams.
 - 3) Installation instructions. Indicate application conditions and limitations of use stipulated by product testing agency. Include instructions for storage, handling, protection, examination, preparation, installation, and starting of product.
 - 4) Operation and maintenance manuals.
 - 5) Typical wiring diagrams and risers.
 - 6) The contractor shall submit test reports, manufacturers' specifications and any other information necessary to determine compliance with material and equipment specifications described herein.
 - c. Submit floor plans to locate all devices. Wiring diagrams shall include wire and raceway sizes, fire alarm control panels, riser wiring and associated raceway sizes, wiring details, connections and terminal identification. All devices shall be identified by the same applied identification symbol as shown on the contract documents.
 - d. Submit all load calculations and cable/wire sizing for each branch of the individual fire alarm field circuits. Wire sizing calculations to prove maximum three percent

- (3%) voltage drop at all AC voltages and maximum eight percent (8%) voltage drop at all DC voltages.
- e. Battery sizing calculations.
 - f. Submit a detailed step by step testing procedure for a component by component system functional checkout and test.
 - g. Point to point wiring diagrams and block diagrams of system to be installed. Point to point wiring diagrams may be submitted at time of operation and maintenance manuals in lieu of in submittal brochure. Block diagrams shall be required with Submittals.
 - h. Riser diagrams and floor plans showing conduit runs and number of wires. All devices shall be identified by the same applied identification symbol as shown on the drawings.
 - i. Surge Suppression
 - 1) Surge protective data for 120 volt power source, power circuit, outside signaling circuit, and exterior incoming circuits from other buildings (if any), and outgoing circuits to other buildings (if any).
 - 2) Submit Product Data for each type of suppressor:
 - a) Dimensions.
 - b) Means of mounting.
 - c) Compliance with UL Standards referenced.
 - d) Compliance with IEEE Standards referenced.
 - e) Design type (Hybrid, MOV).
 - f) Size of wire leads.
 - g) Warrantee.
 - h) Performance data showing compliance with performance as specified herein.
 - i) Complete schematic data on each suppressor type indicating component values, part number, conductor sizes, etc.
 - j) Manufacturer's certified test data on each suppressor type.
 - k) Test data from an independent test laboratory.
 - j. Name, qualifications, etc. of company providing and installing system.
 - k. Qualifications of installer. Submit proof installer meets specified requirements.
 - l. Proof of UL Listing. Indicate the UL listing, the UL classification, and NEC insulation type used for each type of wire to be used in installation of fire alarm and communications system.
 - m. Manufacturer's drawings showing all dimensions (height, width, and depth) for all cabinets used to house system components. Provide catalog pages, mounting details and specification sheets for all fire alarm system components and rough-in boxes.
 - n. Submit Florida Registered Firm certificate number.
 - o. Submit Florida Fire Alarm Contractor's license number.
 - p. Submit Fire Alarm Technician(s) Manufacturer's certification.
 - q. Detailed drawing of the Fire Alarm Control Panels layout indicating the exact arrangement of all zones, including expansion zones.
 - r. Coordination Drawing: Coordination CAD drawing of building Fire Command room and equipment layout as shown on drawings, with all panel and rack footprints, using actual manufacturer's dimensions, indicating proper clearances.

- s. Network:
 - 1) Complete description data indicating UL listing for all network components.
 - 2) Complete sequence of operation of all functions of the network.
 - 3) A list of every network node address.
 - 4) A list of every address of every device connected to a network node that is provided for purposes of alarm initiation, status monitoring, supervised notification appliance circuits, and auxiliary control.
 - 5) Complete network wiring diagrams for all components and interfaces to equipment supplied by others.
- t. All drawings required herein shall be on AutoCAD Release 2009 or higher.
- u. Where required by Authority Having Jurisdiction submits signed and sealed documents as required by Authority Having Jurisdiction. Where Authority Having Jurisdiction requires shop drawings to be signed and sealed by a Registered Engineer, Contractor is required to submit same and include in his bid all costs associated with having a Registered Engineer other than the design Engineer of Record perform signing and sealing.

Project Record Documents

- 1. Submit in accordance with Section 01 77 00.
 - a. Updated and revised contract documents to record actual locations (as-installed) of all equipment, devices, initiating devices, signaling appliances, and end-of-line devices.
 - b. Record actual type, size, and routing of cables installed.
 - c. Record all cable identifications.
 - d. Drawings required herein are in addition to those required under "OPERATION AND MAINTENANCE DATA".
 - e. All drawings required herein to be on AutoCAD Release 2009 or higher.

Operation and Maintenance Data

- 1. Submit in accordance with Sections 01 77 00 and 26 02 00.
 - a. A complete as-installed equipment list, listed by room, with manufacturers' names, model numbers, serial numbers, and quantities of each item.
 - b. A complete and correct system schematic, showing detailed connections for all parts of the system, including wire numbers, terminal block numbers and layouts, and other designations and codings (point-to-point wiring diagrams). System performance measurements shall be documented as noted elsewhere in this specification.
 - c. Riser diagrams showing as-installed conduit with pull boxes, outlet boxes, physical cable layouts, part numbers of cable types used, and number of circuits in each conduit.
 - d. Repair parts list for each and every major equipment item furnished.
 - e. Service manuals for each and every major equipment item furnished.
 - f. Manufacturer's warranties and operating instructions for each and every equipment item furnished. Include a copy of the certificate of warranty, signed by both parties.

- g. Technical Systems Operations Manual, custom-written by the Contractor, for the purpose of instructing the Owner's operating personnel in the detailed step-by-step operation of the system and preventive maintenance procedures. This manual shall include descriptions of the system components and their relationship to system function. This manual shall be bound separately and labeled appropriately.
 - h. Surge Suppression
 - a) O & M data to include:
 - 1) All accepted shop drawings, product data, and/or cut sheets.
 - 2) Installation, connection, and maintenance information on each type of surge suppression.
 - 3) Procedure and/or time table for recommended periodic inspection of devices to determine continued usefulness.
 - i. Complete equipment rack layouts showing locations of all rack mounted equipment items.
 - j. CAD floor plans, prepared at a scale of not less than 1/16" = 1'-0" showing detectors, speaker locations and orientation, rack locations, and all other related device locations.
 - k. The Contractor/Installer shall videotape the entire training session(s), and submit the video tape with the Operational Manual.
2. Drawings required herein are in addition to those required under "PROJECT RECORD DOCUMENTS".
- a. All drawings required herein shall be on AutoCAD Release 2009 or higher.

Warranty Requirements:

- 1. Contractor shall warrant the equipment to be new and free from defects in material and workmanship, and will, within one year from date of acceptance by owner, repair or replace any equipment found to be defective.
 - a. No charges shall be made by the installer for any labor, equipment, or transportation during this period to maintain functions.
 - b. Respond to trouble call within twenty-four (24) hours after receipt of such a call.
- 2. Contractor shall guarantee all wiring and raceways to be free from inherent mechanical or electrical defects for one (1) year from date of final acceptance of the system.
- 3. Surge Suppression
 - a. All surge suppression devices shall be warranted to be free from defects in materials and workmanship for a period of five (5) years.
 - b. Any suppressor which shows evidence of failure or incorrect operation during the warranty period shall be repaired or replaced by the manufacturer and installer at no cost to the owner.
 - c. Equipment that is damaged by surges during warrantee period shall be replaced at no expense to Owner.

Additional Devices for Jurisdictional Compliance:

1. Prior to bid, review plans and specifications carefully for compliance with all codes and in particular, the ADA Requirements and NFPA 72. Include in bid price any devices required to provide a fully compliant system. Said additional devices shall be shown on shop drawings submitted by contractor.
2. In addition to the above-mentioned devices, include in his bid price the cost of installing twenty additional audible/visual notification devices (over and above those shown on drawings, required by specifications, or determined by system installed to be required) whose location/need may not become apparent until just prior substantial completion date. At least two weeks prior to substantial completion; system shall be fully operational. After system is operational University of Miami Safety Representative and the system installer shall review the placement of and coverage provided by visual and audible signals throughout the facility for compliance with all codes and in particular, the ADA Requirements and NFPA 72. System installer shall provide the additional devices at locations where the Architect/Engineer requests for complete coverage. The additional devices shall be installed and fully operational prior to date of Substantial Completion.
3. After the project has had its first annual safety inspection the system installer shall install within one weeks' notice any additional audible/visual signals that have been determined to be required during said inspection from the balance of the (20) twenty additional devices noted above. There shall be at no costs for these added devices provided the total does not exceed the balance remaining of the (20) twenty devices noted above. The final balance of the twenty additional devices included in bid price shall be turned over to the owner as spare material after any fire alarm issues identified during the first annual safety inspection are resolved.

Maintenance Service

1. Furnish service and maintenance of fire alarm system for one (1) year from date of Substantial Completion.
 - a. No charge shall be made by the installer and/or contractor for any labor, equipment, or transportation during this period to maintain functions.
 - b. Respond to trouble call within twenty-four (24) hours after receipt of such call.
2. Provide annual testing and inspection of fire alarm system at end of first year in accordance with NFPA 72. Correct any deficiencies found at no cost to the Owner. Affix fire alarm tag to panel.

Maintenance Materials

1. Provide six (6) keys of each type.
2. Provide three (3) of each type of automatic smoke detector without base.
3. Provide three (3) of each type of surge suppression device.

Programming

1. Provide all programming (one (1) original copy on disk or CD ROM of the programming software as provided by the manufacturer) EPROM burners, specialty hardware (excluding generic computer), all access codes and copyrighted software needed for adding, deleting and changing devices in the program, for the Owner's use.

Owner's Instruction:

1. Provide instruction to the Owner's designated personnel upon completion of the system installation. Instruction shall include a functional training session on fire alarm control panel operation and instruction on peripheral device operation, including what are normal indications and alarm indications of each type of new/added device. Videotape all training sessions and deliver (4) copies of tapes to Owner (for use in future training).
2. Include in his bid all expenses to send two (2) University of Miami designated personnel representatives to the "End-User Certification Factory Training Course," at the manufacturer's factory. The course shall be specifically designed to allow University of Miami representatives the skills they need to successfully design, input, and modify, a database that will control the Fire Alarm System. The course shall also provide the skills to install, service and maintain the Fire Alarm System; Factory training for University of Miami Representative shall be completed prior to substantial completion of the project. Training shall provide instructions, licensed software, access codes, and documentation program material, non-assignable and non-exclusive license for in-house Use of the licensed software, and any other requirement to allow University of Miami the capability to add, delete or change devices in the program for the Fire Alarm/Detection system.

System Operation

1. System operation shall meet the operation requirements of all codes and regulatory requirements.
2. Upon activation of the Fire Alarm System by a manual station, smoke detector, or any other new or existing automatic device the following shall take place:
 - a. Energize all alarm signaling devices.
 - b. Sound all audible alarms and flash visual signals throughout the campus.
 - c. Alert proprietary system.
 - d. Cause alarm to be displayed on the annunciator section of the control panel.
 - e. Cause alarm to be displayed on remote annunciator
 - f. Close all doors or fire shutters, held open by automatic release devices throughout the facility, (coordinate with architect and door hardware supplier, provide all electrical required).
 - g. Unlock all electrically locked time-out room doors (coordinate with the architect and door hardware supplier, provide all electrical required).
 - h. Shut down all air handlers, exhaust fans supplying or exhausting air, and fan terminal boxes (FTB).

- i. Shut all fire and/or smoke dampers in ducts associated with the air handling units and exhaust fans which are shut down.
 - j. Transmit signals to the building elevator control panel to initiate return to the main floor or alternate floor.
 - k. Transmit signals to the building automation system to tell system that the fire alarm system has taken control of respective mechanical system.
 - l. Send a signal to all dimming and lighting relay/control systems. Fire alarm signal shall initiate dimming system controls to drive all dimmed circuits to immediate full-on output. Fire alarm signal shall initiate lighting relay/control system to turn on all emergency lighting circuits.
 - m. Send a signal to all non-fire alarm sound reinforcement systems (i.e. Cafeteria, Gymnasium, Multi-Purpose Room, Theater, etc.). Fire alarm signals shall override all other sound systems. Alarm notification signals shall take precedence over all other signals. Operation of other sound systems shall resume after fire alarm system clears alarm.
 - n. Activate the system dialer and transmit the signal to the monitoring contractor, to notify the local Fire Department.
3. System operation shall meet the operation requirements of all codes and regulatory requirements.
 4. Elevator: Smoke detectors associated with elevator lobbies, hoist ways and machine rooms shall be types accepted by the Florida State Fire Marshal under F.A.C. Chapter 4A-47 Uniform Fire Safety Standards for Elevators. Elevator recall shall be initiated ONLY by elevator lobby, hoist ways and machine room smoke detectors. In addition to those functions outlined in "A" above, elevator detector(s) shall initiate the following functions.
 - a. Operation of any one Elevator Lobby or Hoist way Product of Combustion Detectors associated with a single bank of elevators shall signal the elevator controls to commence required procedures for that bank of elevators. Refer to Division 14 for required procedures, floor(s) of recall, and alternate floor(s) of recall.
 - b. Operation of any elevator machine room Product of Combustion Detector that is part of this Fire Alarm System shall signal the elevator controls to commence required procedures for that bank of elevators. Refer to Division 14 for required procedures.
 - c. Activation of the smoke detector(s) in a machine room or hoist way shall cause a suitable warning light to flash. The light is to be located adjacent to the "Phase One" recall switch or elevator hall button at the designated and alternate fire department access level.
 5. System supervisory faults, such as shorts, opens, and grounds in conductors, operating power failure, or faults within supervised devices, shall place the system in the trouble mode, which causes the following system operations:
 - a. Visual and audible trouble signal indicated by zone at the fire alarm control panel.
 - b. Visual and audible trouble signal indicated at remote annunciator panel.
 - c. Trouble signal transmitted to central station.
 - d. Manual acknowledgement function at fire alarm control panel shall silence audible trouble signal; visual signal shall be displayed until initiating failure or circuit trouble is cleared.

6. Alarm Reset: The system shall remain in the alarm mode until manually reset with a key accessible reset function. The system shall reset only if the initiating circuits are cleared.
7. Lamp Test: manual lamp test function causes alarm indication at each lamp on the fire alarm control panel and the remote annunciator.
8. When the fire alarm system is activated as a drill, all incidental functions shall be exercised including notification of the fire department.
9. Where required by codes or authority having jurisdiction:
 - a. When system is silenced by silence switch in control panel, audible alarm is to silence but visual alarm devices are to continue to operate.
10. Fire sprinkler valve tamper switch, when closed, shall annunciate a supervision signal at the fire alarm control panel and annunciator panels, if any. This supervision signal shall not cause a general alarm.
11. Operation of auxiliary contacts in control panel to shut all smoke dampers in ducts associated with air handling units and exhaust fans which are shut down. (These shall not be controlled from detector unit contacts.)

Zoning

1. Alarm Zones
 - a. Regardless of the number of zones shown on drawings, the minimum alarm zones required are:
 - 1) One per building, per floor for pull stations.
 - 2) One per building, per floor for automatic devices.
 - 3) One for each duct smoke detector).
 - 4) Each device shall be individually annunciated/addressable.
2. Notification Zones
 - a. Regardless of the number of zones shown on drawings the minimum notification zones (horns and strobe lights) required are:
 - 1) One (or more) circuit(s) for administration building
 - 2) One (or more) circuit(s) for exterior horns
 - 3) One (or more) circuit(s) for remainder of campus.
 - b. Breakdown circuits as required for load and distances involved.

Materials, Products, Equipment, Manufactured Units**General Equipment and Material Requirements**

1. All equipment shall be new and unused. All components and systems shall be designed for uninterrupted duty. All equipment, materials, accessories, devices, and other facilities covered by this specification or noted on the contract drawings shall be the best suited for the intended use and shall be provided by a single manufacturer.

Raceways

1. General:
 - a. All raceways (conduit, wireways, pull boxes, outlet boxes, etc.) shall comply with applicable requirements of sections within Division 16 of these specifications.
 - b. All raceways (conduit, wireways, pull boxes, outlet boxes, etc.) shall comply with all requirements of the manufacturer of the fire alarm system.
2. Conduit: Comply with Section 16111 except as noted below:
 - a. Pull Cords: Install pull cords in all raceway runs that are installed without cable.
 - b. Size: Minimum size shall be 3/4" conduit.
3. Boxes:
 - a. All outlet boxes, junction boxes, pull boxes, etc. shall comply with applicable section of these specifications.
 - b. Boxes shall be sized as required by the fire alarm system manufacturer and NEC for cables and/or device installed.

Termination Cabinets

- 1, Terminal cabinets are to comply with applicable sections of these specifications.

"Systems" and "Local" Ground Bus

1. Bus to comply with applicable sections of these specifications.

Fire Alarm Control Panel (FACP)

1. General
 - a. Fire alarm control panel shall be of dead front construction and be modular in design. Control panel shall be capable of future expansion and shall provide active signal initiating as noted on drawings (or as herein) specified with zones as noted on drawings (or as herein specified). Control panel shall provide provisions for future expansion. Fire alarm control panel shall be semi-flush mounted (unless otherwise noted on drawings) and located as shown on the drawings.

2. System Capability

- a. Communication with addressable devices: The system must provide communication with all initiating and control devices individually. All of these devices are to be individually annunciated at the control panel. Annunciation shall include "Alarm", "Trouble", "Open", "Short", "Ground", "Device Fail" or "Incorrect Device" conditions for each point.
- b. All addressable devices are to have the capability of being disabled or enabled individually.
- c. Each Signal Line Circuit (SLC) two-wire loop shall be capable of addressing a minimum of ninety-nine (99) addressable devices and ninety-eight (98) monitor or control modules.
- d. Identification of Addressable Devices: Each addressable device must be uniquely identified by an address code entered on each device at time of installation. The use of jumpers to set address will not be acceptable due to the potential of vibration and poor contact.
- e. Wiring Type, Distances, Survivability and Configurations: The system must allow up to 2,500 feet wire length to the furthest addressable device. Style 4 Signaling Line Circuit (as defined by NFPA-72) communications will be provided.
- f. System shall be capable of addressable devices and conventional devices within the same system.
- g. All system circuits shall be inherently power limited per NEC 760.
- h. System shall be capable of communication with a minimum of fifteen (15) remote module locations.

3. Master Controller

- a. Master controller shall be an integral part of the control panel and be microprocessor-based.
- b. Master controller shall store all programming in non-volatile memory.
- c. Master controller shall have an event log capable of storing a minimum of two hundred fifty-five (255) events in non-volatile memory.
- d. Master controller shall include an eighty (80) character Liquid Crystal Display.
- e. Master controller shall include, as a minimum, switches to accomplish Alarm/Trouble Acknowledge, Alarm Silence, Trouble Silence and System Reset.
- f. Master controller shall include, as a minimum, LED's to indicate System Alarm, System Trouble, Supervisory Alarm and System Silence.
- g. Master controller shall support connection of serial remote annunciators.
- h. Master controller shall provide a minimum of two (2) notification appliance circuits (Class A or B, Style Z or Y).
- i. Master controller shall be capable of being expanded as necessary to accommodate all required modules.

4. Notification Appliance Circuits

- a. Notification Appliance Circuits Module shall provide fully supervised style Z or Y (Class A or B) indicating circuits. These circuits shall supervise and power polarity reversing loops containing up to 1.75 amperes of 24 Volt notification devices.

- b. Module shall be provided with pluggable contact wiring terminal strips for ease of installation and service. The terminal strips shall be UL listed for 12 AWG wiring.
 - c. Control panel shall include all equipment required to alert fire department and/or owner's monitoring service.
5. Power Supply
- a. Power supply for the panel and all fire alarms peripheral shall be integral to the control panel. Power supply shall provide all control panel and peripheral power needs as well as 3.0 amperes of unregulated 24 VDC power for external audio-visual devices. Audio-visual power may be increased as needed by adding additional modular expansion power suppliers. All power supplies shall be designed to meet UL and NFPA requirements for power-limited operation on all external signaling lines, including initiating circuits and indicating circuits.
 - b. All power supplies shall be provided by the same manufacturer as the fire alarm control panel (FACP). Power supplies provided by manufacturers other than the manufacturer of the fire alarm control panel (FACP) shall not be acceptable.
 - c. Circuit breakers, or other over-current protection on all power outputs.
 - d. Input power shall be 120 VAC, 60 Hz. Power supply shall provide internal batteries and charger. Internal battery capacity shall be as required.
 - e. Battery pack shall provide maximum normal operating and supervisory power for:
 - 1) 24 hours per NFPA 72
 - 2) Provide low maintenance gel cell type batteries with sufficient ampere-hour rating to meet the above NFPA Standard and to operate all alarm signals for duration of 5 minutes at the end of the required period of time.
6. Modem
- a. A modem shall be provided as an integral part of the fire alarm control panel (FACP). The modem shall provide the Owner with the ability to accomplish the following functions:
 - 1) View device sensitivity information.
 - 2) View system activity in real time.
 - 3) Access and view the system history log.
 - b. Modem shall not allow changes to system programming.
 - c. Modem shall operate at a minimum speed of 9600 baud.
 - d. Modem shall provide an RJ-11 connector for connection to a telephone line.
 - e. Fire alarm contractor shall coordinate with the Premise Distribution System (PDS) contractor and/or the Telephone System contractor for interconnection to a telephone line. Telephone interconnection wiring up to the modem shall be provided by the PDS or Telephone contractor.
 - f. The modem shall mount inside the fire alarm control panel (FACP).
7. Wall Mount Equipment Enclosure
- a. The control panel, and all associated equipment, shall be housed in an enclosure designed for mounting directly to a wall or vertical surface. The back box and door shall be constructed of 16 gauge steel with provisions for electrical conduit connections into the sides and top. The door shall provide a key lock and shall include a glass or other transparent opening for viewing of all indicators.

- b. The enclosure(s) shall be of sufficient size to house all equipment required for this project. All equipment shall be mounted in the enclosure(s) as designed by the manufacturer. Provide enclosures in quantities as required to provide a complete, UL Listed Fire Alarm system.

Remote Annunciator

1. Fire Alarm Annunciator Panel (FAAP) shall be a serial annunciator panel and must be capable of being mounted in a remote location.
2. Annunciator shall be modular using low current circuitry. The annunciator shall be capable of operating on nominal 24 V/DC and be battery backed up.
3. Annunciator modules shall be capable of activating local or remote LED's, relays or graphic panels.
4. All switches shall be a point in the system and be capable of controlling any system output or functions. All LED's and outputs shall be capable of being controlled by any change of state in the system or as a result of a time control, sequence or logic function. LED's and switches shall be able to be clearly marked by the end user.
5. Modular components of the annunciator shall be mounted in a recessed cabinet with hinged door and a Lexan window with key lock.

Manual Station (Non-Break Glass)

1. Manual fire alarm station shall be non-code, non break glass type providing non-coded signals and operating with a double action motion. Upon actuation, they shall not be restorable to normal except by use of a key. The key shall also allow stations to be tested nondestructively. The stations shall be constructed of metal, with operating directions provided on the cover in highlighted, embossed lettering. The words "FIRE ALARM" shall appear on the door in embossed letters one-half inch high or larger. Mount at 48" above finished floor to top and in accordance with NFPA and handicap standards. Manual stations shall be U.L. listed. Unit shall be equipped with an addressable interface module. Stations constructed of plastic will not be acceptable.

Photoelectric Smoke Detector

1. Furnish and install Analog addressable photoelectric smoke detectors, as called for on drawings. The combination detector head and twist-lock base shall be UL-listed compatible with a UL-listed fire alarm panel.
2. Smoke detector shall have a flashing, status-indicating LED for visual supervision. When the detector is actuated, the flashing LED will latch on steady and at full brilliance. The detector may be reset by actuating the control panel reset switch.

3. Sensitivity of the detector shall be monitored without removal of the detector head. Metering test points shall be accessible on the exterior of the detector head. Field adjustment of the sensitivity shall be possible when conditions require a change.
4. Vandal-resistant, security locking feature shall be used in those areas as indicated on the drawings. Locking feature shall be field removable when not required.
5. It shall be possible to perform a functional test of the detector without the need of generating smoke. Test method must simulate effects of products of combustion in the chamber to ensure testing of all detector circuits.
6. To facilitate installation, detector shall be non-polarized. By using a furnished wire jumper, it shall be possible to check circuit loop continuity prior to installing the detector head.
7. Voltage and RF transient suppression techniques shall be employed to minimize false alarm potential. A gated alarm output shall be used for additional detector stability.

Duct Mounted Smoke Detector

1. Duct Mounted Smoke Detector for the fire and smoke detection system shall be a high velocity rated Analog addressable series smoke detector intended for use with ventilation and conditioning ducts.
2. Detector shall provide detection of combustion gases and smoke in air conditioning ducts in compliance with NFPA 90A. Detector shall be UL-listed specifically for the use in air handling systems.
3. Detector shall operate at air velocities ranging from 300 feet per minute to 4000 feet per minute without requiring compensation for operation at specific air velocities. Sampling tubes of proper length shall be provided and installed to match duct width at the installed location.
4. Whether shown on drawings or not, a remote alarm indicator/test station shall be provided for each duct mounted smoke detector to annunciate smoke detector operation remotely. Mount unit in ceiling or wall near respective remote smoke detectors (in an occupied space).

Projected Beam Smoke Detector

1. Furnish and install Projected Beam smoke detectors, as called for on drawings. Detector shall include both the emitter and the receiver and be UL-listed compatible with a UL-listed fire alarm panel. Detector shall provide a Form A dry contact for alarm and Form B contact for trouble.

2. Smoke detector shall have a status-indicating red LED for visual supervision. When the detector is actuated, the LED will illuminate on steady and at full brilliance. Detector may be reset by actuating the control panel reset switch.
3. Detector shall have a range of 35 feet to 320 feet. Detector shall be field adjustable to one of the obscuration settings of 25%, 50% or 70% per span. These settings shall be capable of being verified with calibrated filters.
4. Projected Beam smoke detector shall possess circuitry that automatically compensates for normal ambient changes in the intensity of the emitted beam strength. The microprocessor shall provide compensation for a change in received signal value, over time, caused by contamination of the optics. When this compensating capability reaches a limit, the microprocessor automatically generates a trouble signal.
5. Projected beam smoke detector shall also signal a trouble condition if the beam has a blockage of 90% for more than twenty (20) seconds and automatically reset to normal when the blockage is removed.
6. It shall be possible to perform a functional test of the detector without the need of generating smoke. The test method must simulate effects of products of combustion in the chamber to ensure testing of all detector circuits.
7. To facilitate installation, the detector shall employ signal strength indicating LEDs. Alignment is facilitated by turning an alignment adjustment wheel and monitoring the relative signal strength based upon which LED is lit. The detector shall be installed in accordance with the instructions provided with every unit and the listed Installation, Operation and Maintenance Manual, and the applicable NFPA standards.
8. Projected Beam smoke detector shall include an Addressable Monitor module and a Power Supervisory relay.
9. Voltage and RF transient suppression techniques shall be internal circuitry of the detector to minimize false alarm potential.

Heat Detectors

1. Furnish and install Analog addressable heat detectors, as called for on drawings. Combination detector head and twist-lock base shall be UL-listed compatible with a UL-listed fire alarm panel.
2. Heat detector shall have a flashing, status-indicating LED for visual supervision. When the detector is actuated, the flashing LED will latch on steady and at full brilliance. Detector may be reset by actuating the control panel reset switch.

3. Fixed temperature automatic heat detectors shall be rated at 135 F (unless otherwise noted or required due to ambient conditions; i.e., Kiln Room). Fixed temperature element shall use dual Thermistor technology. Detectors shall have a smooth ceiling rating of 900 square feet. When required, detectors shall be equipped with two (2) Forms 'A' contacts with rating of 3 amps at 6 to 125 volts A.C. and 1 amp at 6 to 28 volts D.C.
4. Detectors shall be installed in accordance with appropriate articles of National Fire Protection Association and the spacing rating assigned by the Underwriters' Laboratories and located as shown on the drawings. Automatic heat detectors shall be Underwriters Laboratories and Factory Mutual approved.
5. Where indicated on the drawings the contractor shall provide heat detectors rated, by the manufacturer, as explosion proof. If not an integral part of the heat detector assembly, the addressable module shall be located outside the area protected by the explosion proof heat detector (but interior to the building) in an accessible area. If the addressable module is located above a gypsum board ceiling the contractor shall provide a fire rated access panel.

Addressable Module

1. Analog addressable device shall be furnished as required to monitor fire alarm or supervisory initiating devices or control auxiliary functions. Each module shall contain address switches to assign a unique input point for programming or control by the system.

Relays

1. Relays required for control (i.e. Air Handler shutdown, Supply Fan shutdown, Exhaust Fan shutdown, Fan Terminal Box shutdown, Door Lock release, Fire Shutter release, Smoke Damper closure, Fire Damper closure, Smoke/Fire Damper closure, or any other interface required by these specifications or applicable codes) shall be UL Listed relays suitable for use in Fire Alarm systems.
2. Per NFPA, relays used for control of other systems shall be located within three feet (3') of the device to be controlled.
3. Relays shall be analog addressable devices powered and controlled from the fire alarm system. Each relay shall contain address switches to assign a unique input point for programming or control by the system.
4. Each relay shall provide at least one set of Form "C" dry relay contacts.

Audible Notification Devices

1. Audible notification devices shall be wall mounted at each location designated on the drawings and/or as specified herein.

2. The audible notification device shall include screw terminals for in-out field wiring. The device shall surface mount to a standard 4" sq. x 2 -1/8" back box.
3. The audible notification devices shall be UL listed for fire protective service and shall provide 24 VDC inputs and sound output of not less than 75 dBA at 10 feet, or more than 120 dBA at the minimum hearing distance from the audible appliance.
 - a. Audible notification device shall compliant with ANSI S3.41 for signal character conformance.
4. Audible notification devices located on the exterior of a building, or in a damp or wet location, shall be a weatherproof version and rated, by the manufacturer, for use in wet locations.

Audible/Visual Notification Devices

1. Audible/visual notification devices shall be wall mounted at each location designated on the drawings and/or as specified herein.
2. Audible/visual notification device shall include screw terminals for in-out field wiring. The device shall surface mount to a standard 4" sq. x 2 -1/8" back box.
3. Audible portion of the audible/visual notification devices shall be UL listed for fire protective service and shall provide 24 VDC inputs and sound output of not less than 75 dBA at 10 feet, or more than 120 dBA at the minimum hearing distance from the audible appliance.
 - a. Audible portion of the audible/visual notification device shall compliant with ANSI S3.41 for signal character conformance.
4. Audible portion of audible/visual notification devices located on the exterior of a building, or in a damp or wet location, shall be a weatherproof version and rated, by the manufacturer, for use in wet locations.
5. Visual portion of the audible/visual notification devices shall comply with the Americans with Disabilities Act which includes the following:
 - a. Lamp shall be a xenon strobe type or equivalent.
 - b. Color shall be clear or nominal white (i.e. unfiltered or clear filtered white light).
 - c. Maximum pulse duration shall be two-tenths of one second (0.2 sec) with a maximum duty cycle of 40 percent. Pulse duration is defined as the time interval between initial and final points of 10 percent of maximum signal.
 - d. Intensity shall be a minimum of 75 candela. Use of visual devices rated at 15/75, 15 or 30 candela shall not be acceptable.
 - e. Flash rate shall be a minimum of 1 Hz and a maximum of 3 Hz.
 - f. More than two visible notification appliances in the same room or adjacent space within the field of view must flash in synchronization. This requirement shall not preclude synchronization of appliances that are not within the same field of view.
6. A suitable polycarbonate cover shall be provided to protect devices at locations where they may be subject to damage such as Gymnasiums.

Visual Notification Devices

1. Visual notification devices shall be wall mounted at each location designated on the drawings and/or as specified herein. Visual notification devices shall be of the flashing type in compliance with Americans with Disabilities Act.
2. Visual notification devices shall comply with the Americans with Disabilities Act which includes the following:
 - a. Lamp shall be a xenon strobe type or equivalent.
 - b. Color shall be clear or nominal white (i.e. unfiltered or clear filtered white light).
 - c. Maximum pulse duration shall be two-tenths of one second (0.2 sec) with a maximum duty cycle of 40 percent. Pulse duration is defined as the time interval between initial and final points of 10 percent of maximum signal.
 - d. Intensity shall be a minimum of 75 candela. The use of visual devices rated at 15/75, 15 or 30 candela shall not be acceptable.
 - e. Flash rate shall be a minimum of 1 Hz and a maximum of 3 Hz.
 - f. Fire alarm system strobes within same room shall flash in synchronization as required by NFPA.
 - g. More than two visible notification appliances in the same room or adjacent space within the field of view must flash in synchronization. This requirement shall not preclude synchronization of appliances that are not within the same field of view.
3. A suitable polycarbonate cover shall be provided to protect devices at locations where they may be subject to damage such as Gymnasiums.

Elevator Warning Light with Flasher

1. Provide complete, indicating light with flasher per F.A.C. 4A-47. Install label as required.

Weatherproof Cover (for Audible and/or Visual Devices)

1. Constructed of clear polycarbonate.
2. For flush or surface mount devices.
3. Provide slotted version for audible/visual devices.
 - a. Maximum of 5 dB loss.
 - b. Provide with brass weep hole.
4. Provide un slotted version for visual only devices.
 - a. Maximum of 3 candela light intensity loss up to 110 candela light source.
 - b. Provide without weep hole.
5. Provide with weather gasket.
6. Spacers for additional depth as required.

7. Provide with tamper proof screws.
8. Design criteria:
 - a. Safety Technology International, Inc. #1220 (audible/visual) or #1221 (visual) series.

Pull Station Security Cover

1. Provide where pull station devices are required to be protected as indicated on the drawings.
2. Shall be UL Listed.
3. Constructed of clear polycarbonate.
4. Provide with battery operated warning horn.
5. For flush or surface mount devices.
6. Provide with weather gasket.
7. Spacers for additional depth as required.
8. Provide with tamper proof screws.
9. Design criteria:
 - a. Safety Technology International, Inc. #1100 Series.

Areas of Rescue Assistance

1. General
 - a. Each Area of Rescue Assistance shall be a single zone.
 - b. Each Area of Rescue Assistance system shall be provided with primary power from the building emergency power system.
 - c. Each Area of Rescue Assistance system shall be provided with battery backup power sufficient to operate the system for a minimum of two hours.
 - d. Each Area of Rescue Assistance master station and call station shall be provided with an "Area of Rescue Assistance Instructions" sign mounted next to the device. This sign shall provide clear and sufficient instructions as to the proper operation of the system. All instructions shall be in compliance with all ADA requirements for size and type and shall be accompanied with Grade 2 Braille.
 - e. System wiring shall consist of 22 gauge (minimum) wire. Four conductors shall be required between the master panel and each call station not to exceed 3000 feet. Five conductors shall be required between the master panel and the control module.
 - f. Power wire shall be 18 gauge (minimum). Two conductors are required between the power supply and the master panel.

2. Master Panel
 - a. Areas of Rescue Assistance communication system master panel shall include one alternate action switch with internal LED indicator for each zone. An audible alarm will be mounted on the master panel which will emit a minimum sound level of 90 dB at 30 cm. A yellow LED light on the master panel will illuminate and the alarm will emit a repeating sound if any of the supervised lines are faulted.
 - b. Master panel shall be constructed of .125" thick anodized aluminum with permanently silk-screened zone designations on the panel as well as a designation strip.
3. Control Module
 - a. Control module shall provide a set of contacts and a fault indicator light for each zone.
4. Call Station
 - a. Call station shall consist of one momentary switch with LED and one audible alarm device with a sound level minimum of 90 dB at 30 cm. Call station will be wall mounted of a flush, stainless steel plate.
5. Design Criteria
 - a. Cornell Communications Series #4100 Rescue Assistance System

Door Holders

1. Electromagnetic door holder/releases shall be installed on each door as detailed on the drawings and/or as specified herein. Holder/releases shall consist of wall mounted and floor mounted electromagnets and a door mounted armature with an adjustable contact plate. Electromagnets shall have a force of attraction of 24 pounds when energized and less than 3 pounds residual power disconnected. Armature contact plates shall have a horizontal adjustment of 25 degrees. The holding force of holder/releases shall be totally Electromagnetic and without the use of mechanical linkage or other moving parts, and they shall normally be energized, and a release accomplished, by interrupting the circuit. Electromagnetic holder/releases shall be controlled by either automatic or manual alarm. Operating voltage shall be 24 volt DC.
2. Electromagnetic door holder/releases, where required, to be supplied and installed by the Contractor and wired in to fire alarm system by systems contractor. Electromagnetic holder/releases shall be controlled by either automatic or manual alarm. Operating voltage shall be 24 volt DC.

Surge Suppression

1. Non-Addressable Initiation Devices:
 - a. Plug-in replacement modular design with associated female wiring connector.
 - b. UL 497B listed and labeled.
 - c. Multi-stage hybrid protection circuit.
 - d. Fail short/fail safe.
 - e. Surge Capacity: 10KA with 8 x 20 waveform, 500A per line with 10 x 700 waveform.
 - f. Clamp Voltage: 150% of circuit peak operating voltage with 100 amp 10 x 700 waveform.
 - g. Maximum Continuous Operating Voltage: 125% of peak operating voltage, minimum.
 - h. Capacitance: 1500 pf.
 - i. Manufacturer:
 - 1) EDCO #PC642C series with #PCBIB base.

2. Addressable Initiation Devices and Data Loops:
 - a. Plug-in replacement modular design with associated female wiring connector.
 - b. UL 497B listed and labeled.
 - c. Multi-stage hybrid protection circuit.
 - d. Fail short/fail safe.
 - e. Surge Capacity: 10KA with 8 x 20 waveform, 500A per line with 10 x 700 waveform.
 - f. Clamp Voltage: 150% of circuit peak operating voltage with 100 amp 10 x 700 waveform.
 - g. Maximum Continuous Operating Voltage: 125% of peak operating voltage, minimum.
 - h. Capacitance: 50 pf.
 - i. Manufacturer:
 - 1) EDCO #PC642C-LC series with #PCBIB base.

3. Horn, Strobe, and Control Power (Low Voltage):
 - a. Plug-in replacement modular design with associated female wiring connector.
 - b. UL 497B listed and labeled.
 - c. Multi-stage hybrid protection circuit.
 - d. Fail short/fail safe.
 - e. Surge Capacity: 5KA with 8 x 20 waveform.
 - f. Clamp Voltage: 150% of circuit peak operating voltage with 100 amp 10 x 700 waveform.
 - g. Maximum Continuous Operating Voltage: 125% of peak operating voltage, minimum.
 - h. Series Resistance: 0.2 ohms total per pair.
 - i. Manufacturer:
 - 1) EDCO #P164 series (1 pair); #P264 series (2 pair), each with #SD12-PC base.

4. Power Circuit (120 volt):
 - a. UL 1449 listed.
 - b. 15 amp, 120V rated.
 - c. Suppressors shall be tested per IEEE, C62.41-1991 for Categories A and B.
 - d. Normal mode (L-N), and common mode (L+N-G) protection.
 - e. Internal fusing.
 - f. Hybrid design.
 - g. Indicators for normal operation and failure indication.
 - h. Enclosure:
 - a) Fire retardant high impact, Phenolic or plastic housing or metal enclosure.
 - i. Clamping voltage UL 1449, Line to Neutral, Category B Impulse At (3KA, 8 x 20 μ s): 385V @ 120V.
 - j. Maximum Surge Capacity: 20,000 amps.
 - k. Maximum Continuous Operating Voltage: 115% of line voltage.
 - l. Provide hardwire connection or add 15 amp receptacle devices to hardwired devices to match equipment being protected and maintain UL listing.
 - m. Provide additional 15 amp in-line fusing as required to comply with UL and the NEC when connected to a 20 amp, 120V circuit.
 - n. Manufacturers:
 - 1) Leviton #51020-WM (hardwired).
 - 2) EDCO #HSP-121BL2.

5. Terminations
 - a. Provide terminals sized for circuits required on project.
 - b. Where surge suppression modules are for mounting on 'M' block assembly, provide M block assembly complete with grounding system that mates with surge suppression equipment.

6. Terminal Cabinets
 - a. Provide terminal cabinets for all terminations and surge suppression equipment including 120VAC power surge suppressor as required in Section 16289. Size terminal cabinets as required to facilitate installation of terminations and surge suppression in a neat and workmanlike manner.
 - b. Terminal cabinet to meet specifications in Section 16160 unless specifically manufactured for use.
 - c. Manufacturers:
 - 1) Interior.
 - a) Square "D"
 - b) Hoffman
 - c) BUD
 - 2) Exterior.
 - a) Hoffman
 - b) BUD
 - c) Carlon

Cable

1. Contractor shall provide and install cable as required by the manufacturer, as specified elsewhere in these specifications, and to provide a complete, fully operational, UL Listed Fire Alarm system.
2. Fire alarm system cables installed in interior, exterior and/or underground raceways shall comply with the applicable sections of NEC Articles 760, 770 and 800.
3. Zip and zip type cables (e.g. West Penn 970, 971, 972, 974 or similarly constructed cables from other manufacturers) shall not be acceptable.
4. Wiring color code shall be as follows:

a.	Horns/Strobes	Black/Red
b.	Door Holders	White
c.	A.H.S.D.	Purple
d.	Gas Shut-Off Pull Stations	Orange
e.	Addressable	Twisted Pair Data Wire
f.	Hard-Wired	Brown/Blue

Water flow Detector

1. Water flow switches to be supplied and installed by the mechanical contractor and wired in to Fire Alarm System by systems contractor. Zone as shown on zone schedule.

Sprinkler Supervisory Switches

1. Supervisory Switch to be supplied and installed by mechanical contractor and wired in to Fire Alarm System by systems contractor. Zone as shown on zone schedule.

Pressurization

1. Upon alarm from the Fire Alarm System, the Fire Alarm Control Panel shall activate pressurization fans for both stairwells and the elevator shaft. Systems contractor shall provide control relay, 24 V.D.C. coil, one per fan, to accomplish this action. Smoke dampers on the roof shall be closed in order for pressurization to be accomplished.

Field Quality Control

Installation

1. Contractor is advised that circuit routing for this system is not necessarily shown on the project drawings. The contractor shall provide and install all raceways, wiring and cabling required for a complete and fully functional system as intended by these specifications. All wiring and/or cabling shall be in conduit. Contractor shall provide and install a properly sized, flush mounted outlet box for every device. Contractor shall size and route raceways

to accommodate the proper installation of the system cabling. T-Tapped cabling shall not be acceptable. In locations where raceway and/or conduit is not accessible after completion of the project, conduit shall be routed from device to device or fire rated access panels shall be installed to provide access to junction and pull boxes. Routing of raceway from device to device shall only be acceptable where the wiring scheme of the system, as recommended by the manufacturer, requires cable to pass from device to device. Contractor shall properly terminate each device according to the manufacturer's recommendations. Firestopping, where penetrations are made through rated walls and floors, shall be required (See Division 7 Section).

2. Locate, install, and test fire alarm and detection systems in accordance with the equipment manufacturer's written instructions, and the latest editions of the National Electric Code, the National Electrical Contractors Association publication "Standard of Installation" and all applicable codes and standards referenced in this specification.
3. Provide all work required for a complete system including complete system testing and checkout. All components shall be properly mounted and wired. The installation of this system shall comply with the directions and recommendations of authorized factory representatives.
4. Provide wiring, cabling, raceways, and electrical boxes in accordance with manufacturer's written instructions.
5. Components shall be electrically "burned-in" by operating the component at full power for a period as recommended by the manufacturer.
6. Installation shall be done in a neat workmanlike fashion by a firm regularly engaged in Fire Alarm Installation and Service.
7. The installation and inspection of all fire detection and fire alarm devices and systems shall be performed by, or under the direct on-site supervision of, a licensed fire alarm technician or a fire alarm planning superintendent who shall certify the work upon completion of the activity. The certifying licensee shall be present for the final test prior to certification.
8. As-built plans and wiring diagrams shall bear the signature and license number of the licensed fire alarm planning superintendent, the date of installation and the name, address, and certificate-of-registration number of the registered firm.
9. All components shall be completely wired. System shall be fully operable when main power service has failed and the Emergency Standby Generator has assumed emergency system loads. This shall require that any devices which required 120 volt power shall receive supply from an emergency 120 volt source.
10. Installation of detectors:
 - a. All ceiling mounted detectors shall be installed in accordance with the requirements of NFPA 72.

- b. All concealed detectors shall be provided with a remote indicating lamp and test switch installed in an occupied space (corridor, etc.) on wall or on the ceiling grid indicating the type of detector and the zone to which it is connected. Label shall be red with white lettering.
- c. Duct detectors shall be installed in accordance with NFPA 90A. All brackets and hardware shall be provided as required to install detector housing in correct position. All detector housings shall be sealed as required to prevent air leakage between duct and housing. Sampling tubes of proper length shall be provided and installed to match duct width at the installed location.

Raceways and Boxes

1. Provide dedicated raceway with applicable boxes for all fire alarm wiring in accordance with applicable sections of these specifications.
2. All initiating, indicating and auxiliary control devices shall be mounted on UL listed outlet boxes.
3. Provide supporting devices per Section 16190.
(Note: Engineer shall provide specification if required by scope of work.)
4. Identify raceways and boxes per Section 16195.
(Note: Engineer shall provide specification if required by scope of work.)

Wire/Cable

1. Conductor: 98% conductivity, stranded copper with maximum of 7 strands. Stranded conductors shall have a compression lug installed at every end. Wrapping twisted strands at terminal block screw is not acceptable. As an acceptable equivalent, stranded conductors without crimp-on lugs may be terminated into terminal strips of box-lug connectors. Solid copper is not acceptable.
2. Insulation: A type accepted by NEC for the application. All cable shall be UL listed for fire-protective signaling application. Communication, Class 3 or Multi-Purpose cables shall not be substituted for FP cable types.
3. Size: All conductors shall be sized as prescribed by the system manufacturer, with following minimums:
 - a. Multiplex Signaling Line Circuit: AWG #14 shielded twisted pair.
 - b. Notification Circuits, Devices: AWG #14.
 - c. Initiating Circuits, Hard-Wired Devices: AWG #14.
 - d. Initiating Circuits, Addressable Devices: AWG #14 shielded twisted pair.
 - e. Provide larger conductors where required to maintain voltage drop or signal strength within acceptable limits.

4. The above wire sizes shall be increased to size as required to comply with authority having jurisdiction or as required for voltage drop, load, etc.
5. Color Coded:
 - a. Wiring shall be color coded as required to match existing system.
 - b. Permanent wire materials shall be used to identify all splices and terminations for each circuit at all junction boxes, outlet boxes, and terminations.
6. UL:
 - a. General: Fire-protective signaling cable shall be UL listed as non-power limited or power limited as needed to match the output of the fire alarm equipment.
 - b. Non-Power Limited: Fire protective signaling circuits classified as non-power limited shall use cable listed under UL Electrical Construction Materials Directory. Category HNHT, "NON-POWER LIMITED FIRE-PROTECTIVE SIGNALING CABLE". all such cable shall have fire resistance, listing and markings as described in NEC 760-17. Minimum cable marking shall be NPLF.
 - c. Power Limited: Fire protective signaling circuits classified as power limited shall use cable listed under UL Category HNIR, "POWER LIMITED FIRE-PROTECTIVE SIGNALING CABLE". All such circuits shall be durably marked where plainly visible at terminations to indicate that it is a power-limited fire protective signaling circuit. Refer to paragraph titled "Fire Resistance of Cables" for additional requirements.
 - d. Fire Resistance of Cables: Power-limited fire-protective signaling circuit cables shall be UL listed as described in NEC 760. All such cable shall bear a cable marking that includes a Type designation as given in NEC 760. Provide Type FPL.
7. Connections of Installation Wiring:
 - a. Connections to Equipment: In accordance with NFPA for monitoring integrity and with the equipment manufacturer's instructions.
 - b. Connections of installation wiring to alarm initiating devices and alarm indicating appliances shall be monitored for integrity.
 - c. Interconnecting means shall be arranged so that a single break or single ground fault will not cause an alarm signal.
 - d. Apply a compression lug, similar to T&B Sta-Kon Terminal, to all stranded conductors at terminations or use box-lug terminal strips.
 - e. There shall be no wire splices. All wiring shall be continuous, uncut between devices and terminal blocks.
8. Rated Enclosures:
 - a. All vertical fire alarm wiring traversing more than one level shall be routed in rated enclosures. In addition, all horizontal wiring serving devices located on floors other than where wiring originates shall be routed in 2-inch concrete encasement, suitable rated building construction, or 2-hour wrap application enclosure accepted by local authority having jurisdiction.

Manual Pull Stations

1. Install at 48 inches to top above finished floor.
2. All manual stations shall be in unobstructed locations.
3. Install to comply with NFPA, ADA, and all handicap/accessibility code requirements.
4. Provide, install, and connect additional pull stations (from that shown on drawings) as required to comply with above requirements.

Audible Signal Devices, Visual Signal Devices or Combination Audible/Visual Signal Devices

1. Shall comply with NFPA, the Americans with Disabilities Act and other applicable handicap/accessibility codes including but not limited to the following:
 - a. Wall mounted devices shall have their bottom edge at heights above the finished floor of not less than 80 inches and no greater than 96 inches.
 - b. In general, no place in any room or space required to have a visual signal appliance shall be more than 50 ft. (15 m) from the signal (in the horizontal plane). In large rooms and spaces exceeding 100 ft. (30 m) across, without obstructions 6 ft. (2 m) above the finished floor, such as auditoriums, devices may be placed around the perimeter, spaced a maximum 100 ft. (30 m) apart, in lieu of suspending appliances from the ceiling. Placement of visual devices shall not be less than the requirements as specified by NFPA 72.
 - c. No place in common corridors or hallways in which visual alarm signaling appliances are required shall be more than 50 ft. (15 m) from the signal. Placement of visual devices shall not be less than the requirements as specified by NFPA 72.

End-Of-Line Device

- A. Mount end-of-line device box with last device or separate box adjacent to last device in circuit.

Auxiliary Control Relays

1. An auxiliary fire alarm relay used to control an emergency control device, e.g. motor controller for HVAC system fan or elevator controller shall be located within 3 ft. of the emergency control device.
2. The installation wiring between the system panel and the auxiliary fire alarm relay shall be monitored for integrity.
3. Auxiliary control relays shall be listed for use with fire alarm systems.

Sprinkler Flow Switches

1. Coordinate the electrical and operating characteristics of the flow switches with the fire alarm panel.
2. Run conduit and wiring to the flow switches, and connect them so as to provide an operable supervised sprinkler alarm system per NFPA standards, and state and local codes.
3. Provide all electrical including zones as required by authority having jurisdiction and codes.

Sprinkler Valve Supervisory Switches

1. Coordinate the electrical and operating characteristics of the supervisory switches with the fire alarm panel.
2. Run conduit and wiring to the supervisory switches, and connect them so as to provide an operable supervised sprinkler alarm system per NFPA standards, and state and local codes.
3. Provide all electrical including zones as required by authority having jurisdiction and codes.

Door Electric Lock and Hold-Open Power Systems

1. General: Provide 24V-dc low voltage power to all building doors with openers, hold-open devices, closers or electric locks. Refer to Architectural door hardware schedule for doors that may have electric holders or locks. Low voltage power supplies for door hardware shall be furnished separately from the fire alarm system. The fire alarm system shall only provide the unlocking or release control signals and auxiliary control relays at power supplies, in order to reduce power draw on fire alarm system power supplies and batteries.
2. Low Voltage Power: Provide a low voltage transformer on each floor having doors with electric hardware. Transformer shall be 120-24V ac, sized as required to handle load served. Mount in a NEMA 1 enclosure above accessible corridor ceiling outside the first door closest to fire alarm riser. Provide transformer primary fusing to comply with NEC. Provide a 24V ac-24V dc rectifier on the secondary side of the transformer. Provide dedicated branch circuit from closest 120V normal power panel. Provide necessary interposing auxiliary control relay(s) to accept unlocking/release and restore signals from the fire alarm system.
3. Wiring: Electric hardware shall be connected for fail-safe operation. Upon loss of normal power hardware shall unlock without unlatching. Hold-open doors shall release for closure. Restoration of hardware power shall be automatic after the fire alarm system unlock control is reset. Provide all wiring necessary to connect transformer. Provide all low voltage wiring to connect electric locks. Extend wiring down hinge side of stair door jamb through hinge plate into door and through door to electric lock mechanism.

4. Fire Alarm Unlocking Control: All door hardware circuits shall be controlled by fire alarm system. Upon receipt of signal from fire alarm system all door holders shall release and stair/egress door electric locks power system shall be disabled allowing all locks to unlock (without unlatching). Signal to activate shall be automatic fire alarm signal or manual command initiated in the building Fire Control Room. Manual unlock override command shall be through override system. Reference paragraph entitled "FIRE DEPARTMENT OVERRIDE CONTROL PANEL". Provide pilot light and 3-position override switch. ON position (illuminated red pilot light) shall initiate fail-safe operation. OFF position shall restore low voltage power. Provide separate override switch for door openers associated with Atrium Smoke Exhaust System.
5. Mount outlet box for electric door holder to withstand 80 pounds (36.4 kg) pulling force.

Gas/Fuel Shut-Offs

1. Whether shown on drawings or not provide gas/fuel shut-off systems for each and every gas/fuel supply as required by the applicable codes and standards.

Elevators

1. Operation of elevators under fire or other emergency conditions - elevators having a travel distance of 25 feet or more shall conform to the requirements of ANSI A17.1, Safety Code for Elevators and Escalators, Rule 211.3, 1997 Edition, as incorporated herein by reference.
2. When an automatic sprinkler system is required to be installed throughout a building for complete fire protection coverage, the provisions of ANSI A17.1, Rule 102.2 (1997), which is incorporated herein by reference, shall be applicable. When an automatic sprinkler system is required to be installed, the automatic sprinkler system shall be a pre-action sprinkler system and the pre-action sprinkler shall be installed in the elevator machine room and elevator hoist way. An accepted fixed temperature (135 degrees F.) heat detector shall be installed in the elevator machine room, elevator pit, and elevator hoist way as an integral part of the pre-action sprinkler system to automatically disconnect the main power supply to the affected elevator(s) prior to the application of water. The main power supply shall not be self-resetting. The activation of sprinklers outside of the hoist way or machine room shall not disconnect the main power supply. The sprinkler head located in the elevator machine room and elevator hoist way shall have an activation temperature greater than the accepted fixed temperature heat detector.
3. In addition to the requirements of ANSI A17.1, Rule 211.3(b) (1997), an accepted smoke detector(s) shall be installed in the elevator hoist way, and the machine room meeting the requirements of Rule 4A-47.008. The activation of the smoke detector(s) in the machine room or the elevator hoist way shall cause a suitable warning light to flash. The light is to be located adjacent to the "phase one" recall switch required by ANSI A17.1 Rule 211.3(a) (1997) or elevator hall button. The warning light shall be red, and a minimum diameter of 1/8 inch. A sign shall be incorporated with or adjacent to the light and contain the following wording "DO NOT USE ELEVATOR". The minimum size for the letters on the sign shall be 1/8 inch. Provide supervised fire alarm system wiring and power to elevator warning

lights. Lights shall function per elevator bank. Provide and install light at first floor and alternate floor as directed by authority having jurisdiction.

4. Provide detectors with auxiliary relay complete with tie into elevator controller as required by all codes, or provide separate zone.

Cable Identification

1. Provide and install permanent cable markers on all cables/wire lines, telephone lines, etc. at terminal strips, terminal cabinets and at main equipment.

Internet Connection

1. Provide new connection from a data outlet (RJ45 connection) mounted adjacent to the FACP to the nearest PDS rack for connection to the internet. Provide the iComSL as required for communication to the fire alarm monitoring contractor.

Surge Protection

1. General
 - a. Provide, install and connect new surge suppression equipment as specified herein, including protection of equipment power source, cable/wire entering or leaving building housing, main fire alarm system equipment, ground lugs, and #6 copper ground wire in 3/4" c. to existing main building service ground.
 - b. Extreme care shall be taken by contractor to assure a properly surge protected system.
 - c. Surge protection equipment must be selected by contractor to match the equipment being protected including wire sizes, operating volts, amps, and circuit impedance.
 - d. Installation of surge protection equipment and its grounding must be per manufacturer's recommendations to assure short and proper ground paths.
2. Equipment Selection
 - a. Contractor to coordinate with suppliers and installers of all equipment being protected and provide surge suppression equipment which meets these specifications on respective equipment, wires, etc.
3. Equipment Installation
 - a. Install surge suppression equipment per manufacturer's recommendation at each wire terminal as noted under Part 1.
 - b. Install in surge suppression equipment terminal cabinets, etc. as required to facilitate installation of surge protection equipment and terminal points. Increase size of terminal cabinets (from that shown on drawings) to size required to facilitate installation of surge suppression equipment and terminal blocks.
 - c. Locate surge suppression equipment in terminal cabinet nearest main equipment cabinet (FACP).
 - d. Coordinate with Section 16289 contractor to assure that surge suppression for 120VAC power circuit and surge suppression required by this section are all installed in same terminal cabinet and bonded together.

4. Ground Installation
 - a. Ground Bus Connections
 - 1) Provide "local" ground bus in each terminal cabinet housing surge protection equipment (with lugs, etc. as required).
 - 2) Bond "local" ground bus to terminal cabinet with minimum #6 copper wire.
 - 3) Connect terminal cabinet "local" ground bus to "systems" ground bus installed per 16170 with minimum #6 copper insulated wire (unless otherwise noted) in conduit.
 - 4) Note that "systems" ground bar is also to be used for power transformation ground (480V to 208V) where applicable.
 - b. Surge suppression equipment grounding.
 - 1) Connect each surge suppressor to local ground bus in terminal cabinet with wire sized as recommended by manufacturer. Where "M" block type terminations/surge suppressors are used, bond ground rail to local ground bar with wire as recommended by manufacturer.
 - 2) Coordinate with Section 16289 contractor to assure that 120VAC power source/supply surge suppressor is also grounded to same local ground bus as surge suppressors provided in this section for same system (i.e. fire alarm, intercom, television, etc.).
 - c. Conductors
 - 1) Conductors shall meet requirements of Section 16123. Minimum size to be #12 THWN.
 - 2) Bends in excess of 90 degrees in any grounding conductor shall not be permitted. A radius of 6 inches or greater shall be maintained on all bends.
 - 3) Do not bundle unprotected conductors with protected conductors.
 - 4) Conductors shall be kept as short as possible.
 - 5) Conductors shall be secured at 12" intervals with an accepted copper clamp.
 - 6) Grounding conductors shall be properly connected to the building service ground by accepted clamps.
 - d. Grounding Connectors
 - 1) Connectors, splices, and other fittings used to interconnect grounding conductors, bond to equipment or grounding bars, shall be accepted by NEC or UL for the purpose.
 - 2) All connectors and fittings shall be of the Nicopress crimp or compression set screw type.
 - 3) Special treatment to fittings, lugs, or other connectors of dissimilar material shall be applied to prevent electro-galvanic action.

Conduit/Box Identification

1. Contractor shall identify fire alarm conduit and boxes with red paint in exposed locations. Identify conduit in concealed locations with 4" mark of red paint every 4'-0" O.C.

Demonstration

1. When system is complete it shall be demonstrated to Owner's Representative who shall be given complete instructions, spare parts, manuals and maintenance information.

System Testing

1. Prior to certification of the fire alarm system the contractor shall accomplish a complete test of the fire alarm system in accordance with NFPA 72, Test Methods.
2. Perform a complete, functional, component by component test of the entire fire alarm and detection system. Provide a detailed step by step testing procedure which is unique to this project, reflecting the type of system and the number and location of all components.
3. Perform a sensitivity test of all smoke detectors and duct detectors. Perform a calibration / test of heat sensors.
4. Demonstrate the proper operation of each component as follows:
 - a. Photoelectric, and duct smoke detectors: activate the detector with a "false smoke" product which has been specifically formulated for testing smoke detection systems.
 - b. Heat detectors: activate the detector by utilizing the detector check button.
 - c. Pull Stations: activate the station by operating the station in its normal mode.
 - d. Audible and Visual Alarms: verify proper operation when the system is put into the alarm mode.
 - e. Sprinkler Flow Switches: open the sprinkler system's inspection test valve. Verify that the flow switch sends an alarm signal within the allowed time corresponding to the switch's time delay setting.
 - f. Fire Alarm Panels: functionally check-out and test the panel per the manufacturer's written instructions. Demonstrate the proper operation of each modular component. Demonstrate automatic power change to batteries and back to building power upon a drop in voltage below the voltage threshold as specified by the panel manufacturer.
5. Demonstrate the supervisory function at each device loop circuit, and at all single component wiring runs such as for the sprinkler valve supervisory switches.

Certification

1. After completion of the installation of the system, the licensee shall complete a NFPA Inspection and Testing form. The Inspection and Testing form format shall be as indicated in NFPA 72, Inspection and Testing Form. When an Inspection and Testing form has been completed, legible copies shall be distributed as directed by the Authority Having Jurisdiction.
2. After an installation has been complete, affix a Fire Alarm Tag to the control panel. The Fire Alarm Tag is in addition to the Inspection and Testing form. Protect the Fire Alarm Tag from vandalism by applying pressure sensitive label; do not use a "tie-on" tag. It shall be as required in the Fire Safety Rules.

Final Drawings

1. As-built drawings shall be given to the Owner's representative, at time of instruction, in addition to those to be supplied as general requirements of the job.

Authority Having Jurisdiction

1. The drawings and specifications herein comply to the best of the engineer's knowledge with all applicable codes at time of design. However, it is this contractor's responsibility to coordinate/verify (prior to bid) the requirements of the authority having jurisdiction over this project and bring any discrepancies to the engineer's attention at least 7 days prior to bid. No changes in contract cost will be acceptable after the bid for work/equipment required to comply with the authority having jurisdiction.

28 35 00 Refrigerant Detection and Alarm**System Description**

1. Provide a refrigerant gas detection system where indicated in Contract Documents containing a series of detection points located in areas where refrigerant from a leak is likely to accumulate and / or be sensed. Include analyzer, sequencer and interface control panels(s), filters, sensors, alarm signaling devices, piping and all components necessary for a complete operational system.
2. System shall provide various stages of alarming and control chiller room mechanical ventilation in accordance with sequence of operation at values not to exceed specified TLV. System shall be capable of detecting the presence of the refrigerant(s) actually used on this project. System shall be capable of detecting, indicating, alarming, shutting down equipment, interfacing to building automation and security systems, as specified below, on contract documents, and per applicable codes, standards, and regulations.
3. Under circumstances directed by regulations for mechanical equipment room design, refrigerants requiring LEL monitoring below 4% by volume, shall employ the appropriate sensing technology and conform to Class 1, Division 2, National Electrical Code requirements. When refrigerant groups A2, A3, B2 other than NH3, and B3 are used, follow appropriate guidelines indicated in regulations concerning area classification requirements.
4. Monitoring shall be employed to provide minimum two (2) points of area sampling and (1) point of relief vent monitoring for each chiller. Additionally, monitoring shall be provided for any pit areas located in the chiller mechanical room. Diluted samples due to ventilation air flow currents shall employ multi-point monitoring techniques strategically located according to regulation guidelines. System design considerations shall also incorporate leak detection monitoring sensing locations for early warning indication to prevent a major loss of refrigerant without alarm, should a leak occur. Where multiple refrigerant types are used, it is the system suppliers responsibility to properly select the quantity and type of refrigerant detectors and multi-point sequential sampling systems required to safely

monitor the equipment room. Provide components and system safety and interface logic as outlined following without exception. Provide number of sampling points as indicated on plans with 20% spare sample point capability on analyzer and expansion module.

Submittals

1. Product Data:
 - a. For each type of refrigerant monitor, include refrigerant sensing range in ppm, temperature and humidity range, alarm outputs, display range, furnished specialties, installation requirements, and electric power requirement.
2. Shop Drawings:
 - a. Air-Sampling Tubing: Size, routing, and termination including elevation above finished floor.
 - b. Wiring Diagrams: Power, signal, and control wiring.
3. Coordination Drawings: Include machinery-room layout showing location of monitoring devices and air-sampling tubing with filter/inlet locations in relation to refrigerant equipment.
4. Product Certificates: For monitoring devices, signed by product manufacturer.
5. Field quality-control test reports.
6. Operation and Maintenance Data: For refrigerant monitoring equipment to include in emergency, operation, and maintenance manuals.

Coordination

1. Coordinate refrigerant detection and alarm system with refrigerant contained in refrigeration equipment for compatibility.

Extra Materials

1. Provide all necessary calibration gas and hardware for two years operation in a portable case. Turn over to owner after successful system start up.

Products / Manufacturers

1. Subject to compliance with requirements, provide products by one of the following:
 - a. Ino-Tek, Romeo, Michigan.

Control Panel and Control Panel Equipment

1. Analyzer: Provide NEMA 4 wall mount enclosure. Analyzer shall employ infrared sensor macro light pipe gas cell technology, to provide sensing down to one (1) part per million (ppm) and shall be compound specific and calibrated for refrigerant as specified below or required per chiller manufacturer's requirement. Analyzer shall have capability to be switched to monitor, at a future date, another refrigerant type by changing one part and

recalibration. (i.e. CFC-11 to HCFC-123, etc.) Provide menu driven microprocessor based electronics with user friendly programming allowing operator to select alarm set points, auto zero frequency, latched or unlatched alarms, and to program sample distance in feet for each sample point. Analyzer shall automatically select sequencing and sample dwell time based on programmed distance to each sample point. First level warning alarm shall comply with recommended AEL of 10 ppm +/- 1 ppm. Base analyzer unit shall be capable of monitoring one (1) or four (4) sample points with expansion capability to four (4), seven (7) or eleven (11) sample points. LCD digital display shall show concentration levels from all four sample points simultaneously. Readout for seven (7) or eleven (11) point monitoring systems shall sequence with sample point being monitored. Flashing alarm LCD indication shall be provided for alarm level #1, #2, #3, malfunction, flow loss, and zero cycle. Auto zero calibration can be initiated manually at the monitor or automatically at preprogrammed user selectable intervals, or remotely from a dry contact input. Analyzer shall automatically zero by drawing air from an uncontaminated air source. Include built in sample pump. Differential pressure flow loss indication will occur when flow goes below 500 ml/min. Analyzer outputs available shall be Common Alarm Level 1, 2, and 3 contacts, Malfunction, (4) 4-20 mADC analog signals (1 for each channel) and a RS-485 output of refrigerant level available for input into BMS. Analyzer inputs shall be external zero initiate and external alarm reset. Contact rating 240 v/ac, 5 amp resistive or 2 amp inductive. Power requirements 75 watts. Unit shall be insensitive to vibration and shall provide for a continuous sample. Intermittent dump and purge, batch type sampling with long response times shall not be acceptable. Response time shall be twenty (20) seconds to ninety-nine (99%) percent minimum. Malfunction relay is de-energized on heater out of control, chopper failure, pump flow loss, analyzer low flow or malfunction alarm. Provide expansion card with three (3) alarm contacts for each channel. Group common alarm contacts so as to make most common operating sense. Common alarm output signal shall be provided for relief vent monitoring. All sample points shall have individual alarm set point adjustment capability whether standard common alarms or individual expansion board is used.

2. Local Interface Panel: Include all alarm logic, system interlocks, interface relays, alarm reset with remote capability, alarm test, trouble relay, etc. as outlined below and on drawings. All control system interlocks and logic shall be provided in local interface panel.
3. System shall be configured to provide additional dry contact alarm contacts and output signals for control or for interface as follows and noted on drawings:
 - a. With building management system:
 - 1) Maintenance dry alarm contact.
 - 2) AEL level; low leak warning dry alarm (first level) contact.
 - 3) TLV - TWA level; high level danger dry alarm (second level) contact.
 - 4) STEL level; high level danger dry alarm (third level) contact available; use only when noted.
 - 5) (1) 4-20 ma/dc process concentration signal for each channel.
 - 6) On systems greater than four (4) channels (1) 4-20 ma/dc signal shall provide for continuous ppm readout and (1) 4-20 ma/dc signal shall provide for stepped channel indication.
 - 7) RS - 485 signals.
 - 8) Common chiller relief vent alarm as grouped per analyzer.

- b. With chiller room ventilation system direct interlock required:
 - 1) Direct interlock to Purge Air Supply and Exhaust Fan starter control circuit. Purge Mode.
 - 2) Direct interlock to Purge Mode damper controls.
 - c. With combustion equipment located in chiller room direct:
 - 1) Direct interlock to shut down at TLV-TWA level.
4. Alarms shall be provided at the AEL and TLV-TWA level, and also for malfunction. At the AEL level, the system shall actuate the warning amber beacon and the audible horn and an alarm signal shall be sent to MSU Physical Plant Central Control. At the TLV-TWA level, the system shall activate the purge ventilation system, energize the red beacon, sound the refrigerant leak audible alarm, shut down area combustion equipment, and send an alarm signal to MSU Police and Public Safety to contact ORCBS via page. If a system malfunction shall occur, a blue beacon shall be energized at the locations indicated on the drawings and at the interface panel with no audible alarm at this level, and a trouble alarm signal shall be sent to MSU Physical Plant Central Control. Provide dry alarm contacts for each alarm level for interface to the BMS. All control system interlocks and logic shall be provided in local interface panel. Where indicated; third level contacts shall be used to initiate area ventilation prior to TLV level so as to prevent shutdown of combustion equipment. Relief vent alarm shall indicate via common contact to the BMS and provide for local alarm horn only at interface panel and interface panel pilot light indication. No alarm beacons shall be energized on relief vent alarm. Analyzer display shall indicate which channel is in alarm.
5. Purge Ventilation: Upon system reset, the alarm beacons shall be deactivated only if the area monitored has returned to a safe condition. The purge ventilation system shall remain activated for 30 minutes after the alarm condition has cleared. A panel mounted pilot light shall indicate that the purge ventilation system is still activated. Provide a manual selector switch for "Auto - Manual On" purge fan control.
6. Alarm Relays: Provide plug in type, two (2) per channel (level 1 & 2) wired to DPDT isolated 5 amp terminal. Relays shall be de-energized during normal operation and shall energize upon alarm. Alarm contacts shall be available for each point of alarm from each sensing point back to the BMS and shall be used to energize various devices and equipment as outlined above and on the drawings. Alarm levels shall be field adjustable. Alarms will be provided at the AEL level, TLV-TWA level, and for malfunction from the interface panel.
7. Alarm Reset: Provide push button reset switch on front of interface control panel to acknowledge and silence or reset the self latching alarm circuit. The alarm beacons and horns shall remain on until the system is reset from the panel face or from remote reset pushbutton. The alarms shall stay latched to prevent them from automatically resetting when the toxic condition goes away. This control logic shall be provided for in the interface panel.
8. Alarm Test: Provide push button switch inside interface control panel to test alarm circuitry and panel indicators. During test function, output signals to the BMS and combustion shutdown shall be disabled.

9. Trouble Relay: Provide one (1) common malfunction relay for system interface to building security or BMS. Relay shall be energized in normal operation, de-energized due to malfunction at any channel.
10. Pilot Light Indication: Provide panel indication for power on, zone alarm status where applicable, alarm status for relief vent alarms, and purge fan status.
11. Power Supply: Provide terminals for dedicated 115 v/ac, 60 Hz. input power supply. Power all alarm and warning devices and remote indication control panel from this control panel circuit. All remote field devices associated with this system shall be 120 vac or as indicated.
12. Tagging: Provide "Lamacoid" tag, red background with 1/2" high white letters at each remote visual and audible device. Anchor tag to wall adjacent to wall mounted devices, suspend with brass security chain adjacent to ceiling mounted devices.
13. Tags located inside and outside mechanical room shall be inscribed as follows:
 - a. DANGER - REFRIGERANT R-____
 - b. BLUE - REFRIGERANT LEAK DETECTION MALFUNCTION.
 - c. AMBER - CAUTION - REFRIGERANT LEAK DETECTED.
 - d. RED - DANGER - REFRIGERANT LEAK DETECTED. UNSAFE TO ENTER ROOM WITHOUT PROPER BREATHING APPARATUS.
 - e. NOTIFY BUILDING ENGINEER OR SECURITY IMMEDIATELY UPON INDICATION OF ANY ALARM.
14. Tags located near horn inside mechanical room shall be inscribed as follows:
 - a. DANGER - REFRIGERANT R-____
 - b. LEAVE ROOM IMMEDIATELY IF HORN SOUNDS.
 - c. NOTIFY BUILDING ENGINEER OR SECURITY IMMEDIATELY UPON INDICATION OF ANY ALARM.
15. Balance of tag information must comply with CFR requirements and provide emergency action required upon entering or leaving the premises. Indicate on tag the remote reset pushbuttons. All tag information shall be provided by the system supplier.
16. Provide alarm horns and beacons equal to Federal Signal where indicated on drawings. Beacons shall be strobe, three color; blue, amber, and red in mechanical room; amber and red in areas outside mechanical room and outdoors. Alarm beacons shall be located at each entrance to mechanical room and in clear view in event of alarm. Beacon assemblies outdoors shall be NEMA 4 rated. Where pilot lights are used for annunciation purposes use Allen - Bradley; push-to-test or equal.
17. Remote Reset: Provide minimum (1) remote reset pushbutton assembly at main entrance to mechanical room and additional where indicated on drawings to allow reset / silence from safe location. Remote pushbutton station shall be compatible with room decor. Signs at remote reset assembly shall denote a safe and unsafe@ response action relating to local beacons and entrance to monitored area upon depressing remote reset pushbutton. Upon reset, if the area monitored has been purged to a safe level the beacons shall be deactivated and safe entry shall be permitted.

18. Calibration Gas 3-Way Valve Assembly: Provide between analyzer and sequencing assembly or sample line when all analyzer sample lines are utilized, clearly identified and tagged, to allow admission of calibration zero and span gas directly into analyzer without disconnecting sample tubing.
19. Portable Leak Check Stations: System shall be supplied with device to pinpoint specific refrigerant leak location after system has alarmed and identified leak has occurred. Device shall allow maintenance personnel to pinpoint exact location of refrigerant leak to perform required repairs. One (1) portable leak check station shall be mounted at each chiller and at locations as indicated on drawings. Provide portable leak check station device Model #LC-10 as manufactured by Ino-Tek, Romeo, MI or approved equal.
20. Filters: Inlet sample filter shall be mounted at each area sample point and each relief vent sample point. Provide two (2) years of spare filter elements figuring one (1) element per sample point for every (3) months of operation. Provide wall or uni-strut mountable filter bracket assembly with sample filter and direct compression fitting connection to installer supplied 1/4" o.d. copper sample line as indicated on the drawings.

Execution Installation

1. Comply with ASHRAE 15.
2. Install air-sampling inlets, or diffusion type monitors in pits, tunnels, or trenches in machinery room that are accessible to personnel.
3. Floor mount diffusion-type monitor, sensor/transmitters, or air-sampling inlets on slotted channel frame 12 to 18 inches (300 to 450 mm) above the floor in a location near the refrigerant source or between the refrigerant source and the ventilation duct inlet.
4. Wall mount air-sampling multiple-point monitors with top of unit 60 inches (1525 mm) above finished floor.
5. Run air-sampling tubing from monitor to air-sampling point, in size as required by monitor manufacturer. Install tubing with maximum unsupported length of 36 inches (915 mm), for tubing exposed to view. Terminate air-sampling tubing at sampling point with filter recommended by monitor manufacturer.
6. Install air-sampling tubing with sufficient slack and flexible connections to allow for vibration of tubing and movement of equipment.
7. Purge air-sampling tubing with dry, oil-free compressed air before connecting to monitor.
8. Number-code or color-code air-sampling tubing for future identification and service of air-sampling multiple-point monitors.
9. Extend air-sampling tubing from exhaust part of multiple-point monitors to outside.

10. Extend air-sampling tubing from outdoors to outdoor inlet connection of NDIR monitors. Terminate air-sampling tubing at outdoor inlet location with filter recommended by monitor manufacturer.
11. Place warning signs inside and outside each door to the refrigeration equipment room. Sample wording: "AUDIBLE AND VISUAL ALARM SOUNDING INDICATES REFRIGERANT DETECTION - ENTRY REQUIRES SCBA."
12. Audible Alarm-Indicating Devices: Install at each entry door to refrigeration equipment room, and position not less than 6 inches (150 mm) below the ceiling. Install horns on flush-mounted back boxes with the device-operating mechanism concealed behind a grille.
13. Visible Alarm-Indicating Devices: Install adjacent to each alarm horn at each entry door to refrigeration equipment room, and position at least 6 inches (150 mm) below the ceiling.
14. System supplier shall have turnkey responsibility to provide mechanical and electrical installation, provide on-site installation supervision, and properly locate sampling points after review of chiller room air flow and ventilation patterns.
15. Sample locations indicated on drawings are approximate and must be field verified by system manufacturer with air flow profile tests. Air flow profile tests shall be turned over to owner as part of the safety certification documentation. Final location of sample points shall be determined after all chiller room ventilation systems and equipment have been installed, and properly balanced. It is the system supplier's responsibility to insure that enough sample points exist to properly monitor air samples both under normal ventilation conditions and under purge ventilation conditions. Air profile test should indicate air flow pattern prior to alarm and after alarm to insure that safe monitoring exists under both conditions.
16. Install equipment in accordance with applicable codes and manufacturer's printed instructions. Route conduits and tubing as required to make neat and operating system. Sample inlet tubing shall be 1/4" o.d. rigid copper, properly supported, and run neatly parallel with, or at right angles to building construction. Tubing shall be void of kinks, sags and other irregularities. All bends shall be made with a tube bender.

Field Quality Control

1. General:
 - a. Prior to project completion and when directed by Owner's Representative, manufacturer factory trained representative shall program, start up, thoroughly test and calibrate, set alarm threshold levels, and verify that system is in compliance with operational sequence. Should corrections be required to any system, and after corrections have been completed, system shall be re-tested.
 - b. Assist MSU ORCBS and Physical Plant Maintenance Department in development of emergency procedures.
 - c. Tests shall be witnessed by Owner or his designated representative and a letter shall be submitted certifying system performance.

2. Safety Certification:
 - a. Furnish Owner with written report certifying that work has been accomplished with results. Provide Safety Certification documentation to the owner including the following: Air Flow Profile Report for each sample point location, Calibration Report with before and after results of each analyzer, Alarm / Interface Report stating all threshold levels, alarm and interface action at each level of alarm with field verification report, Safety Training Checklist, and List of all owner attendees.
 - b. Near end of warranty period of operation, provide similar service as described above complete with written report. Should a control or device be suspect in its operation or function, this deficiency shall be reported to operating personnel, documented in report, and replaced.
 - c. Post Construction On Site Service: Each six months after final acceptance until warranty expires, systematically inspect, examine, clean and adjust when necessary, detector, panels, relays, self-contained breathing apparatus, and accessories pertaining to system. Provide updated pertinent reports.

Demonstration

1. Engage a factory-authorized service representative to train University of Miami Owner's maintenance personnel to adjust, operate, and maintain refrigerant detection devices. Refer to requirements in Division 01 Section "Demonstration and Training."

DIVISION 31 EARTHWORK

This chapter identifies criteria for earthwork design with the purpose of establishing minimum standards, acceptable to UM, to be used as the basis of design for UM Coral Gables campus buildings.

- 31.1 General Requirements
 - 31.1.1 Submittals
- 31.2 Codes and Standards
 - 31.2.1 Earthwork
 - 31.2.2 Structural Design Standards
- 31.3 Design Criteria
 - 31.3.1 Earthwork
 - 31.3.2 Termite Control
 - 31.3.3 Auger Piles Design
- 31.4 Specific Earthwork Requirements (organized by CSI MasterFormat® 2012 Numbers & Titles)

31.1 General Requirements

All work shall be designed by a Professional Civil Engineer licensed in the State of Florida.

The Design Professional shall obtain from the UM Project Manager the following information:

1. Site surveys
2. Underground utilities information
3. Geotechnical investigation reports
4. Traffic studies
5. Transportation routes and drop-off locations.

The design of the Earthwork must be implemented so there is minimum impact on adjacent buildings, paved areas, vegetation or existing waterways and aquifer. The Design Professional shall specify that all excavation be implemented safely and in compliance with the Trench Safety Act. The Design Professional shall specify the Termite Control and note that all work shall comply with EPA Regulations. The Design Professional must ensure that design of the Auger Piles shall conform to all applicable codes

The Design Professional shall obtain a copy and become familiar with the University of Miami Campus Area Development Plan (UMCAD). In addition, the Design Professional shall adhere to the Edges of Spatial Definition guidelines described in the UMCAD and shall follow the design intent described in UMCAD. The intent should achieve an enduring regional equivalent to other campuses mentioned in UMCAD.

The design of the Earthwork and Auger Piles shall complement other disciplines designs in a sustainable and reliable fashion.

UM Coral Gables Campus and UM Buildings Earthwork and Structural Systems must be designed to comply with the following objectives:

1. Sustainable Design
2. Minimum elevations of finished on-site grading and building lowest finished floor elevations shall comply with highest elevation requirements of:
 - a. Federal Emergency Management Agency (FEMA)
 - b. Federal Standard 44 CFR (National Flood Insurance Program)
 - c. Miami-Dade County Permitting, Environment and Regulatory Affairs - Natural Resources Regulation & Restoration Division
3. Solutions with the best value considering a life cycle cost analysis to account for total project cost

These objectives are in line with the objectives of all Divisions and should be coordinated with all disciplines in a holistic way.

During the life span of a typical UM building, many minor and major alterations are necessary. The flexibility to adjust to alterations easily must be designed into the building and underground systems from the outset. The design of the Underground systems shall provide enough capacity for future additions or renovations and allow modifications to be made in one area without causing major disruptions in other areas of the site. It is the UMBS Committee's goal to build facilities equipped with the latest advances in technology. Making this concept a reality requires a comprehensive design for engineering systems that goes beyond the requirements of the immediate building program. It also requires a higher level of integration between architecture and engineering systems than one would usually expect in an office building. The design of the underground systems and other building components shall all be combined together to produce a building that meets the programmed sustainability rating (LEED rating) of the specific project. In addition, the design work shall be done in accordance with all rules, regulations, and requirements of all authorities having jurisdiction.

31.1.1 Submittals

The Design Professional must ensure that all submittals and shop drawings are coordinated with other disciplines.

31.2 Codes and Standards

31.2.1 Earthwork

Site clearing, dewatering, earthwork, excavation and termite control shall comply with the requirements of the applicable authorities having jurisdiction and with the in-force edition at the time of the project of the following codes and standards:

1. Trench Safety Act - Florida Statutes, Chapter 553, Part VI
2. Occupational Safety and Health Administration (OSHA) - Excavation Safety Standards

3. American Society of Testing and Materials (ASTM) Standards
4. Miami-Dade County Permitting, Environment and Regulatory Affairs
5. City of Coral Gables Department of Public Works
6. State of Florida Department of Environmental Protection (FDEP)
7. Environmental Protection Agency (EPA) Regulations

31.2.2 Structural Design Standards

Auger Pile Design shall comply with the requirements of the applicable authorities having jurisdiction and with the in-force edition at the time of the project of following codes and standards:

1. American Society of Civil Engineers– ASCE-705
2. American Concrete Institute – ACI-301 and ACI-318

31.3 Design Criteria

31.3.1 Earthwork

The Design Professional shall specify the Earthwork covered in this section, which include Clearing and Grubbing, Earth Moving, Dewatering and Excavation Support and Protection.

1. Clearing and grubbing should include the following:
 - a. Removing from site or transplanting of all required vegetation within the construction area.
 - b. Protecting of all vegetation to remain.
 - c. Removing from site all undesirable materials.
 - d. Stripping and stockpiling for later re-use all clean topsoil encountered.
 - e. Capping of all required utilities
 - f. Implementing all necessary erosion and sedimentation control measures.
2. Earth Moving should include the following:
 - a. Preparing subgrades and sub base courses including cutting or filling and compacting for slabs-on-grade, sidewalks and asphaltic and concrete pavements.
 - b. Excavating, backfilling and compacting for buildings foundations, piping and underground structures.
 - c. Sub bases for grass areas and planting areas.
 - d. Subsurface drainage backfill for walls and trenches.
3. Dewatering shall be designed and provided by contractor. Contractor to comply with the regulations of Miami-Dade County Permitting, Environment and Regulatory Affairs and the City of Coral Gables Department of Public Works.
4. The Contractor shall engage the services of a Professional Engineer licensed in the State of Florida to design the excavation support and protection.

31.3.2 Termite Control

1. The Design Professional shall specify the termicide installation and ensure it complies with all the requirement of the regulations of the Environmental Protection Agency (EPA) .

31.3.3 Auger Pile Design

1. The Design Professional shall design the Auger intrusion mortar cast in place piles. These piles shall be installed under the supervision of a qualified professional geotechnical engineer.

31.4 Specific requirements (organized by CSI MasterFormat® 2012 Numbers & Titles)

31 10 00	Site Clearing
31 20 00	Earth Moving
31 23 19	Dewatering
31 31 16	Termite Control
31 50 00	Excavation Support and Protection
31 62 13	Concrete Piles

31 10 00 Site Clearing

Design Standards

1. The Design Professional shall design the site clearing to include the following:
 - a. Protection of all vegetation to remain. If an endangered plant species is found, provide an undisturbed area around it as required by FDEP.
 - b. Removal of vegetation as required.
 - c. The clearing and grubbing of obstructions, trees, shrubs and other vegetation, including grinding stumps and removing roots and debris.
 - d. The stripping and stockpiling of topsoil and the removal of surplus topsoil.
 - e. The removal of existing above and below grade site improvements.
 - f. The disconnection, capping or sealing, and removal of site utilities.
 - g. The installation of temporary erosion and sedimentation control measures.

31 20 00 Earth Moving

Design Standards

1. The Design Professional shall design the Earth Moving as follows:

- a. Design the preparation of subgrades including cutting and filling, as necessary, and compaction for slabs-on-grade, sidewalks, pavements, turf and grasses, and plants.
 - b. Specify the methods for excavation, backfill and compaction for buildings and structures.
 - c. Design of Sub base course, including compaction for concrete walks and concrete pavements.
 - d. Design of Sub base course and base course, including compaction, for asphalt paving.
 - e. Design of Subsurface drainage backfill for walls and trenches.
 - f. Specify the methods for excavation, backfill and compaction of trenches for utilities and pits for buried utility structures.
 - g. Specify that explosives are not allowed.
 - h. Geotextiles:
Design of usage of drainage geotextiles and separation geotextiles wherever are necessary.
 - i. Excavation:
 - (1) Excavation design shall cause minimal disturbances to adjacent occupied areas.
 - (2) Specify hand-excavation in tree and plant protection zones.
 - (3) Specify the disposal of Surplus and Waste Materials:
Satisfactory soil to designated storage areas on Owner's property;
waste materials and unsatisfactory soil off Owner's property.
2. Compaction as recommended by the geotechnical report or as follows:
- a. Required compaction of sub base, sub base courses and surfaces as a percentage of maximum density as obtained by test procedures of ASTM D1557.
 - b. Compaction shall be as follows:

Under structures and building slabs, except footings, each layer.	95%
Under footings, top one foot of cut each layer of fill.	100%
Under pavements and sidewalk areas, top 12 inches, each layer.	95%
Under pavements and sidewalk areas, below 12 inches, each layer.	90%
Under landscaped areas, each layer.	85%

- 3. Testing requirements.
 - a. Testing: By Owner engaged agency.

31 23 19 Dewatering**Design Standards**

1. Dewatering shall be designed by the Contractor as follows:
 - a. Contractor to be supplied with a copy of the geotechnical report.
 - b. Contractor to survey adjacent construction for settlement before and during dewatering.
 - c. Contractor to maintain water level as deep as necessary below bottom of excavation.
 - d. Contractor to comply with the regulations of Miami-Dade County Permitting, Environment and Regulatory Affairs and the City of Coral Gables Department of Public Works.

31 31 16 Termite Control**Design Standards**

1. Termite Control as follows:
 - a. The installer shall be licensed according to regulations of authorities having jurisdiction.
 - b. Termicide installation shall comply with all required EPA regulations.
 - c. The Warranty Period shall be five (5) years.
 - d. Maintenance shall continue for twelve (12) months.

31 50 00 Excavation Support and Protection**Design Standards**

1. Contractor shall engage a design professional to design excavation support and protection whenever trench depth exceeds five (5) feet as follows:
 - a. Contractor to be supplied with a copy of the geotechnical report
 - b. Contractor's design professional to specify required materials.
 - c. Remove excavation support and protection to a minimum depth of 48 inches below overlying construction.

31 62 13 Concrete Piles**Design Standards**

1. Design Professional shall design the auger intrusion mortar cast in place piles as follows:
 - a. Design Loads: As required for particular application.
 - b. Quality Assurance:
 - (1) Grout cubes during construction.
 - (2) Evidence auger weight is sufficient to penetrate soil profile.

- c. Materials
 - (1) Steel Reinforcement: Deformed reinforcing bars.
 - (2) Pile Accessories:
 - (a) Sheet metal collars at cut-off.
 - (b) Spacers to maintain vertical reinforcing in position.
- d. Concrete: As required by pile capacity.
- e. Installation:
 - (1) Static pile tests to verify augering criteria and pile lengths and to confirm allowable load of piles.
 - (2) Damaged or defective piles withdrawn.
 - (3) Pile installation records compiled by qualified professional geotechnical engineer.
- f. Field quality control
 - (1) Special Inspections: Pile foundations.
 - (2) Testing: By Owner engaged agency.
 - (3) Pile installation records compiled by qualified professional geotechnical engineer.

DIVISION 32 EXTERIOR IMPROVEMENTS

This chapter identifies criteria exterior improvements design with the purpose of establishing minimum standards, acceptable to UM, to be used as the basis of design for UM Coral Gables campus buildings.

- 32.1 General Requirements
 - 32.1.1 Required site information
 - 32.1.2 Submittals
- 32.2 Codes and Standards
 - 32.2.1 Exterior Site Furnishings
 - 32.2.2 Asphalt Pavement, Concrete Paving, Decorative Concrete Paving, Concrete Paving Joint Sealant, Unit Paving, Permeable Unit Paving, Parking Bumpers, Pavement Markings and Manufactured Traffic Calming Devices
 - 32.2.3 Planting Irrigation,
 - 32.2.4 Turf and Grasses, Plants and Transplanting
 - 32.2.5 Chain Link Fences and Gates
 - 32.2.6 Decorative Fences and Gates
- 32.3 Design Criteria
 - 32.3.1 Exterior Site Furnishings
 - 32.3.2 Asphalt Pavement, Concrete Paving, Decorative Concrete Paving, Concrete Paving Joint Sealant, Unit Paving, Permeable Unit Paving, Parking Bumpers, Pavement Markings and Manufactured Traffic Calming Devices
 - 32.3.3 Planting Irrigation
 - 32.3.4 Turf and Grasses, Plants and Transplanting
 - 32.3.5 Chain Link Fences and Gates
 - 32.3.6 Decorative Fences and Gates
- 32.4 Specific exterior improvements Requirements (organized by CSI MasterFormat® 2012 Numbers & Titles)

32.1 General Requirements

All work shall be designed by a Professional Civil Engineer licensed in the State of Florida and a Registered Landscape Architect licensed in the State of Florida, as required. Improvements will be constructed in accordance with the expected standard of design professionals within the State of Florida.

The design and of the exterior Improvements shall:

1. Be implemented in such a way so existing structures, hardscape, landscape, or improvements to remain are not damaged.
2. The design shall take into account that access to or the functioning of improvements to remain shall not be hindered during the construction period. Specify that the contractor

- is responsible for creating a 'maintenance of operations' plan for approval by UM's project manager prior to the commencement of any demolition or construction activities. This plan will also identify all safety measures proposed to protect pedestrians around and within the construction area as well as maintenance of traffic schedules and plans.
3. The design shall compliment existing improvements in character and scale to enhance the collegiate atmosphere and shall adhere to the 'Edges of Spatial Definition Guidelines' and other applicable sections of the University Campus District (UCD), per Coral Gables Zoning requirements.
 4. The design shall comply with the Americans with Disabilities Act as codified within the latest edition of the Florida Building Code, Chapter 11, 'Florida Accessibility Code for Building Construction' to create an inviting and accessible campus.
 5. Follow 'Crime Prevention Through Environmental Design' (CPTED) principles to ensure a safe university environment.
 6. Coordinate with other disciplines on, adjacent to, or impacted by the proposed improvement project, including but not limited to utility companies.
 7. Design shall include sustainable design regarding construction methods and material choices, maintenance required, and water and fertilization requirements.
 8. Provide the best value to the University when considering the project's total life cycle cost.
 9. Prior to any excavation, locate, mark and ID all existing UG utilities/correlate to GIS data.
 10. Prior to covering new and/or exposed existing UG utilities, contact UM PM for update of UG utilities location database.
 11. Sidewalks shall be 6" thick with WWM and edge re-bar reinforcement.
 12. Sidewalks and concrete in general shall have fly ash content per LEED Silver criteria, whether or not the project is intended to be LEED certified.
 13. For veneer finishes, provide waterproofing prior to application of veneer, compatible with the bonding requirements of the finish system.
 14. Concrete pavers to be 12" x 12" or 6" x 6" shellstone (Oldcastle Coastal) in a grid pattern at pedestrian areas, or 4" x 6" (herringbone) at vehicular surfaces. Approved colors are cream, grey or Coral Gables beige. All three colors of pavers may be used with or without shellstone aggregate.
 15. Consider recycled materials for walkways.
 16. Coordinate exterior lighting with the UMBS Committee's lighting standards and standard fixtures as outlined in Division 26 Electrical of these Building Standards.

17. Wheel stops at parking stalls are not allowed, unless curb wheel stopping is not possible, or Zoning mandates otherwise.

The above objectives are in line with the objectives of all Divisions and should be coordinated with all disciplines in a holistic way.

The design of the Exterior Improvements shall complement other disciplines designs in a sustainable and reliable fashion.

32.1.1 Required Site Information

The Design Professional shall obtain from the UM Project Manager the following information:

1. Site surveys, current to existing improvements and specific to the site.
2. Tree surveys for all trees over 6 inches diameter breast height (DBH) and arborist reports regarding the health of trees.
3. Utilities information including above and below ground utilities.
4. Geotechnical investigation reports..

32.1.1 Submittals

The Design Professional must ensure that all submittals and shop drawings are coordinated with other disciplines.

32.2 Codes and Standards

32.2.1 Exterior Site Furnishings

The Design Professional shall specify that the Exterior Site Furnishings comply with the requirements of the applicable authorities having jurisdiction and with the in-force edition at the time of the project of the following codes and standards:

1. American Society of Testing and Materials (ASTM)
2. Consumer Product Safety Commission (CPSP)
3. City of Coral Gables Building and Zoning Department

32.2.2 Asphalt Pavement, Concrete Paving, Decorative Concrete Paving, Concrete Paving Joint Sealant, Concrete Curbs, Concrete Curbs and Gutters, Unit Paving, Permeable Unit Paving, Parking Bumpers, Pavement Markings and Manufactured Traffic Calming Devices,

The Design Professional shall specify that the Asphalt Pavement, Concrete Paving, Decorative Concrete Paving, Concrete Paving Joint Sealant, Concrete Curb, Concrete Curbs and Gutters, Unit Paving, Permeable Unit Paving, Parking Bumpers, Pavement Markings and Manufactured Traffic Calming Devices comply with the requirements of the applicable authorities having jurisdiction and with the in-force edition at the time of the project of the following codes and standards:

1. American Society of Testing and Materials (ASTM)
2. American Association of State Highway and Transportation Officials (AASHTO)
3. Coral Gables Department of Public Works
4. State of Florida Department of Transportation (FDOT)
5. American Concrete Institute (ACI)
6. Interlocking Concrete Pavement Institute (ICPI)
7. The Master Painters Institute (MPI)
8. Federal Specifications (FS)

32.2.3 Planting Irrigation

The Design Professional shall specify that the Planting Irrigation comply with the requirements of the applicable authorities having jurisdiction and with the in-force edition at the time of the project of the following codes and standards:

1. American Society of Testing and Materials (ASTM)
2. American Society of Mechanical Engineers (ASME)
3. Miami-Dade Water and Sewer Department (MDWASD)
4. American Water Works Association (AWWA)
5. City of Coral Gables Department of Public Works (CGDPW)
6. State of Florida Department of Transportation (FDOT)

32.2.4 Turf and Grasses, Plants and Transplanting

The Design Professional shall specify that the Planting Irrigation, Turf and Grasses, Plants and Transplanting comply with the requirements of the applicable authorities having jurisdiction and with the in-force edition at the time of the project of the following codes and standards:

1. American Society of Testing and Materials (ASTM)
2. United States Department of Agriculture (USDA)
3. Environmental Protection Agency (EPA)
4. American Society of Civil Engineers (ASCE)
5. Turfgrass Producers International (TPI)
7. American National Standards Institute (ANSI)
8. American Wood Protection Association (AWPA)
9. Grades and Standards Publications, Division of Plant Industries,
State of Florida Department of Agriculture
10. Standardized Plant Names, American Joint Committee on Horticultural
Nomenclature
11. International Society of Arboriculture (ISA)
12. American Society of Consulting Arborists (ASCA)
13. Americans with Disabilities Act (ADA)
14. City of Coral Gables Planning Department
15. State of Florida Department of Transportation (FDOT)

32.2.5 Chain Link Fences and Gates

The Design Professional shall specify that the Chain Link Fences and Gates comply with the requirements of the applicable authorities having jurisdiction and with the in-force edition at the time of the project of the following codes and standards:

1. American Society of Testing and Materials (ASTM)
2. American Society of Civil Engineers (ASCE)
3. Chain Link Fence Manufacturers Institute (CLFMI)
4. National Electrical Manufacturers Association (NEMA)
5. City of Coral Gables Zoning Department

32.2.6 Decorative Fences and Gates

The Design Professional shall specify that the Decorative Fences and Gates comply with the requirements of the applicable authorities having jurisdiction and with the in-force edition at the time of the project of the following codes and standards:

1. American Society of Testing and Materials (ASTM)
2. National Ornamental and Miscellaneous Metal Association (NOMMA)
3. Builders Hardware Manufacturers Association (BHMA)
4. City of Coral Gables Zoning Department

32.3 Design Criteria

32.3.1 Exterior Site Furnishings

The Design Professional shall specify the Exterior Site Furnishings covered in this section.

1. Exterior site furnishing shall be specified to match existing University standard furnishings whenever possible and appropriate.
 - a. Preferred Options:
 - 1) Chair, Manufacturer: Landscapeforms
Verona Chair
Size: Frame is 3/4" tubular steel
DxHxW = 25"x30"x20"
Weight is 30 lbs each
Stackable by 4 chairs only
Style: Perforated with no arms
Color: Silver
 - 2) Table, Manufacturer: Landscapeforms
Steelhead Perforated Tabletop w/ surface mount
Steelhead perforated metal table top w/ 1-1/2" diameter tube
(umbrella hole)

- Table top, 42" diameter
 - Height is 30"
 - Weight is 150 lbs each
 - Support/Mounting: Quad - Surface Mount
 - Table Top/ Supporting Base Color: Silver
 - 3) Umbrella, Manufacturer: Landscapeforms
Equinox Umbrella
Weight is 40 lbs each
Umbrella will be mounted to table support, not to the ground.
Style: Plain Edge cover
Fabric Color: Tuscan
Powdercoat Color: Silver
Mounting: Table Mount
Standard Features: 1 ½" diameter pole
Standard Fabric: Sunbrella® marine-grade fabric w/ stain
 - 4) Exterior trash Receptacle, Manufacturer: Landscapeforms
Sort Recycling System
Two bin set - two (2) 50 gallon polyethylene containers
Umbrella will be mounted to table support, not to the ground.
Color: To be selected by UM
Powdercoat Color: Silver:
- 2. The design of exterior site furnishings that are not standard University furnishings shall complement the existing and proposed character of the campus and landscape design. Site furnishings shall be constructed of durable materials and anchored in place in a concealed manner when appropriate.
- 3. Preferred Bike Rack: Bola by Landscapeforms. Rack mounting 36" on center, set in concrete foundation beneath concrete pavers on sand, or cored into existing concrete slab with non-shrink epoxy grout. Preferred bike rack area surface is concrete pavers on sand.

32.3.2 Asphalt Pavement, Concrete Paving, Decorative Concrete Paving, Concrete Paving Joint Sealant, Concrete Curbs, Concrete Curbs and Gutters, Unit Paving, Permeable Unit Paving, Parking Bumpers, Pavement Markings and Manufactured Traffic Calming Devices.

The Design Professional shall specify the Asphalt Pavement, Concrete Paving, Decorative Concrete Paving, Concrete Paving Joint Sealant, Concrete Curbs, Concrete Curbs and Gutters, Unit Paving, Permeable Unit Paving, Parking Bumpers, Pavement Markings and Manufactured Traffic Calming Devices covered in this section.

- 1. Asphaltic Pavement should include the following:
 - a. Design of the subgrade including compaction and stabilization if required by soil conditions. Specify minimum thickness.

- b. Design of limerock base including compaction as per FDOT Standards and Specifications. Specify minimum thickness.
 - c. Design of the asphaltic concrete surface as per FDOT Standards and Specifications. Specify minimum thickness.
 - d. Cold milling of existing asphaltic concrete surface when required. Specify depth.
 - e. Design of the asphaltic concrete overlay as per FDOT Standards and Specifications. Specify minimum thickness.
 - f. Compaction testing requirements.
2. Concrete paving should include the following:
- a. Includes concrete pavement, curbs, curb and gutter, valley gutter and concrete sidewalks.
 - 1) Walkways to be designed as per UMCAD.
 - 2) Provide walkways connecting drop-off zones, reserve parking and other facilities to building entrances.
 - 3) Where walkways exceed 150 feet in length, provide rest areas adjacent to walkway at convenient intervals with space for bench seats and wheelchair space, a minimum of 48 inches x 72 inches.
 - 4) Do not place grates or manholes in walkways.
 - 5) Curbs shall not create barriers for the handicap. Curb height shall not exceed six inches.
 - 6) Curb ramps shall be installed at all intersections and wherever walkways cross street or drives. When installed at intersections, a consistent pattern of orientation shall be observed to provide repetitive "cueing" to blind people. Locate and align curb ramps to direct pedestrian traffic into crosswalk areas.
 - 7) Curb ramps located adjacent to parking areas shall not be blocked by parked vehicles.
 - 8) Sidewalk slopes and curb cuts shall comply with MDCPW, Coral Gables ordinances and ADA.
 - 9) Provide sidewalks subject to maintenance trucks and other vehicular traffic with welded wire fabric and reinforced edges. Expansion joints shall not exceed fifteen (15) feet on center.
 - 10) All parking areas shall be fully curbed. Use cast-in-place concrete only. Depth of curb foundation: six (6) inch minimum.
 - 11) Extruded curbing is not permitted.
 - b. Design of the pavement subgrade including compaction and stabilization if required by soil conditions. Specify minimum thickness.
 - c. Design of pavement base:
 - 1) Limerock base as per FDOT Standards and Specifications. Specify minimum thickness.
 - d. Design of concrete pavement, curbs, curb and gutter, valley gutter and concrete sidewalks, shall include the following:
 - 1) Concrete strength or modulus of rupture.
 - 2) Specify reinforcing if any is required.
 - 3) Thickness as required.
 - 4) Spacing of joints and types of joints.
 - 5) Finishes.

- 6) Testing requirements.
3. Decorative concrete paving shall include the following designs:
 - a. Design of the subgrade including compaction and stabilization if required by soil conditions. Specify minimum thickness. Coordinate the sub-base design and compaction requirements with the civil engineering documents.
 - b. Design of the base:
 - 1) Limerock base as per FDOT Standards and Specifications. Specify minimum thickness.
 - c. Design of the concrete pavement including the following:
 - 1) Concrete strength or modulus of rupture.
 - 2) Specify reinforcing if any is required.
 - 3) Pavement Thickness.
 - 4) Spacing of joints and types of joints.
 - 5) Color and finishes.
 - 6) Mockups requirements.
 - 7) Testing requirements.
 4. Concrete paving joint sealant shall include the following designs:
 - a. Design and specification of joint sealants should include the following:
 - 1) Joint sealant application and location.
 - 2) Joint sealant manufacturer and product name.
 - 3) Joint sealant color.
 - 4) Surface preparation before joint sealant installation.
 - 5) Testing requirements of joint sealant.
 5. Unit paving shall include the following designs:
 - a. Design of the subgrade including compaction and stabilization if required by soil conditions. Specify minimum thickness. Coordinate the sub-base design and compaction requirements with the civil engineering documents.
 - b. Design of the base:
 - 1) Limerock base as per FDOT Standards and Specifications. Specify minimum thickness.
 - 2) Concrete base. Specify minimum thickness, concrete strength or modulus of rupture and reinforcing if any is required.
 - c. Specify setting bed and thickness.
 - d. Type of paver unit and color:
 - 1) Concrete pavers by Oldcastle Coastal.
 - 2) Color and unit sizes to match existing or as approved by University.
 - e. Specify joint pattern. Coordinate the paver pattern with the Traffic Engineer at vehicular drop-off areas.
 - f. Specify Mockups requirements.
 - g. Specify testing requirements.

6. Permeable unit paving shall include the following designs:
 - a. Design of the subgrade; open graded for stormwater storage. Specify minimum thickness.
 - b. Design of the base; well graded. Specify minimum thickness.
 - c. Design of leveling course. Specify minimum thickness.
 - d. Specify type of permeable paver unit and color.
 - e. Specify joint pattern.
 - f. Specify Mockups requirements
 - g. Specify testing requirements.
7. The Design Professional shall design the type, size and location of parking bumpers and specify the manufacturer.
8. Pavement markings design shall include the following:
 - a. Specify paint type:
 - 1) Alkyd.
 - 2) Latex.
 - b. Specify wet film thickness
 - c. Specify color and stripe width.
9. The Design Professional shall design the type, size and location of manufactured traffic calming devices and specify the manufacturer.

32.3.3 Planting Irrigation

The Design Professional shall design the Planting Irrigation as follows:

1. Planting Irrigation should include the following design.
 - a. Design of spacing and type of irrigation head.
 - b. Design of piping sizes to obtain the required pressures and flows.
 - c. Specify irrigation controls.
 - d. Specify backflow prevention devices if required.
 - e. Specify wells and pumps if required.

32.3.4 Turf and Grasses, Plants and Transplanting

The Design Professional shall design the Turf and Grasses, Plants and Transplanting as follows:

1. The design professional shall design the landscape to enhance the character of the campus, which is that of a visually pleasing, consistent lush landscape that responds to human and environmental needs, while being responsive to architectural and landscaping precedent and simplified maintenance with an emphasis on drought tolerance and native vegetation. Landscape design shall

abide by the Coral Gables Campus Master Plan and shall be carried out in consultation with the campus tree relocation program.

32.3.5 Chain Link Fences and Gates

The Design Professional shall design the chain link fences and gates. Including location, height, gage, hardware, footings and types of gates as follows:

1. PVC coated fence to match existing at UM. Green in color as approved by the UMBS Committee.
2. Chain link fencing shall have top, intermediate and bottom rails.
3. Fence layout and heights to follow UCD and UM Project Manager requirements.
4. Fence openings to follow UCD and UM Project Manager Requirements.
5. A fencing plan indicating post and fencing locations in relationship to existing to remain and proposed improvements shall be submitted to the UM Project Manager for approval prior to installation. The plan shall adhere to the following requirements:
 - a. Fencing shall be set a minimum of two (2) feet from any existing to remain or proposed tree trunk.
 - b. Fence posts shall be a minimum of two (2) feet from any edge of walk or pedestrian area and a minimum of four (4) feet from any edge of vehicular pavement or access route.
 - c. Fencing and posts shall be located outside of sight triangles at roadway intersections.
6. UM fencing shall comply with applicable Florida Building Code requirements, City of Coral Gables zoning requirements and UCD requirements. Fencing Plan shall be coordinated with appropriate agencies and UCD.

32.3.6 Decorative Fences and Gates

The Design Professional shall design the decorative fences and gates. Including style, location, height, hardware, footings or foundations, gage and types of gates as follows:

1. Acceptable materials:
 - a. Coral rock rubble or natural keystone veneer wall topped with factory coated aluminum metal picket fence similar to existing at UM.
 - b. Masonry wall with painted stucco finish and natural keystone coping similar to existing.
 - c. Masonry wall with natural keystone veneer similar to existing.
 - d. Factory coated aluminum picket fence to match existing at UM.

2. Fence layout and heights to follow UCD and UM Project Manager requirements.
3. Fence openings to follow UCD and UM Project Manager Requirements.
4. A fencing plan indicating post and fencing locations in relation to existing to remain and proposed improvements shall be submitted to the UM Project Manager for approval prior to installation. The plan shall adhere to the following requirements:
 - a. Fencing shall be set a minimum of two (2) feet from any existing to remain or proposed tree trunk. Consult with PM Project Manager and Landscape Architect when distant to tree trunk is less than 10 feet.
 - b. Fence posts or columns shall be a minimum of two (54) feet from any edge of walk or pedestrian area and a minimum of four (4) feet from any edge of vehicular pavement or access route.
 - c. Fencing, posts, and columns shall be located outside of sight triangles at roadway intersections, per Coral Gables Planning and Zoning requirements.
5. UM fencing shall comply with applicable Florida Building Code requirements, City of Coral Gables zoning requirements and UCD requirements. Fencing Plan shall be coordinated with appropriate agencies and UCD.

32.4 Specific requirements (organized by CSI MasterFormat® 2012 Numbers & Titles)

12 93 00	Site Furnishings
32 12 16	Asphalt Paving
32 13 13	Concrete Paving
32 13 16	Decorative Concrete Paving
32 13 73	Concrete Paving Joint Sealant
32 14 00	Unit Paving
32 14 43	Permeable Unit Paving
32 17 13	Parking Bumpers
32 17 23	Pavement Markings
32 17 29	Manufactured Traffic Calming Devices
32 31 13	Chain Link Fences and Gates
32 31 19	Decorative Fences and Gates
32 84 00	Planting Irrigation
32 91 00	Planting Topsoil
32 92 00	Turf and Grasses
32 93 00	Plants
32 96 00	Transplanting
32 97 00	Landscape Stone and Gravel

12 93 00 Site Furnishings**Design Standards**

1. The Design Professional shall design the exterior site furnishings as follows:
 - a. LEED submittals
 - 1) Product Data for Credit MR 4.1 and Credit MR 4.2
 - b. General requirements:
 - 1) At least 50% of the proposed site furnishings for a project shall be handicap accessible, if applicable. If only one of a particular furnishing is proposed, it shall be handicap accessible.
 - 2) All top-opening receptacles shall have a covered opening, via domed lid or bonnet type design to limit rainwater into the bin.
 - 3) All receptacles shall be installed with a liner.
 - 4) Receptacles shall not be located directly adjacent to benches.
 - 5) Bench pads shall have a clear area for adjacent wheelchair parking.
 - a. Benches, and other site items, shall be setback from the edge of the walkways a minimum of 3'-0".
 - 6) Movable seating shall be stackable.
 - 7) If umbrellas are provided, they shall be removable.
 - 8) Removable bollards shall have a locking mechanism.
 - 9) Bike racks shall be located to allow a six (6) foot length 'clear zone' for bike parking, centered on rack and in the direction of the rack. This clear zone shall fall outside of walk or building exit and entry areas. Individual racks shall be located no closer than two (2) feet six (6) inches from one another to allow for access between racks.
 - 10) Bike parking areas shall be lighted.
 - c. Products:
 - 1) Site furnishings shall be selected to be in character and of the same quality of the campus's existing furnishings.
 - 2) Bike racks shall be selected as those which hold the bike by the frame, making contact at two horizontally separate points, minimum.
 - d. Installation:
 - 1) Site furnishings shall be direct burial installation unless hardship from such method is identified to the UM project manager prior to the installation.
 - 2) Utilize tamper-resistant, stainless steel hardware.

32 12 16 Asphalt Paving**Design Standards**

1. The Design Professional shall design the asphalt paving as follows:
 - a. LEED submittals
 - 1) Product Data for Credit MR 4.

- b. Asphalt materials:
 - 1) Asphaltic concrete surface as per FDOT Section 916.
 - 2) Limerock base as per FDOT Section 911
- c. Design mixes:
 - 1) Asphaltic concrete pavement as per FDOT Section 334.
- d. Installation:
 - 1) General construction requirements as per FDOT Section 330.
 - 2) Milling of existing asphalt pavement as per FDOT Section 327.

32 13 13 Concrete Paving

Design Standards

- 1. The Design Professional shall design the concrete paving, which includes concrete pavement, curbs, curb and gutter, valley gutter and concrete sidewalks, as follows:
 - a. LEED submittals
 - 1) Product Data for Credit MR 4.
 - b. Materials:
 - 1) Portland cement, water, admixtures and curing materials as per FDOT Sections 921, 923, 924, and 925.
 - 2) Limerock base as per FDOT Section 911
 - c. Installation:
 - 1) Portland cement concrete as per FDOT Sections 346, 347 and 350.
 - 2) Sidewalks within vehicular use areas or subject to vehicular traffic:
 - a) Six (6) inches thick
 - b) Reinforced with welded wire fabric and reinforced edges
 - c) Expansion joints shall not exceed fifteen (15) feet
 - 3) Sidewalks for pedestrian use only:
 - a) Four (4) inches thick.
 - b) Unreinforced with troweled joints.
 - c) Expansion joints shall not exceed forty (40) feet and shall be the full thickness of the walk.
 - d) Control joints shall be not exceed five (5) feet and shall be troweled to a depth of 1/3 that of the thickness of the walk.
 - 4) Curbing to comply with FDOT Index No. 300.

32 13 16 Decorative Concrete Paving

Design Standards

- 1. The Design Professional shall design the decorative concrete paving as follows:
 - a. LEED submittals
 - 1) Product Data for Credit MR 4.

- b. Materials:
 - 1) Portland cement, water, admixtures and curing materials as per FDOT Sections 921, 923, 924, and 925.
 - 2) Limerock base as per FDOT Section 911
 - 3) Colors compatible with Portland cement admixtures and curing materials.
- c. Installation:
 - 1) Portland cement concrete as per FDOT Sections 346, 347 and 350.

32 13 73 Concrete Paving Joint Sealant

Design Standards

- 1. The Design Professional shall design the concrete paving joints materials as follows:
 - a. Materials and Installation:
 - 1) Concrete joint sealants as per FDOT Section 932.

32 14 00 Unit paving

Design Standards

- 1. The Design Professional shall design the unit paving as follows:
 - a. LEED submittal:
 - 1) Product certificates for Credit MR-5.
 - b. Materials:
 - 1) Standard paver shall be Oldcastle Coastal or approved equal by the UMBS Committee.
 - Colors:
 - a) Cream with shellstone aggregate.
 - b) Cream without aggregate.
 - c) Coral Gables Beige without aggregate.
 - d) Grey
 - Sizes:
 - a) Standard manufacture's square or rectangular sizes, no polygonal allowed.
 - Design requirements:
 - a) Color mixing allowed in borders, band or geometrical patterns, random mixing is prohibited.
 - b) Herringbone pattern using Coral Gables Beige pavers without aggregate is preferred where subject to vehicular traffic, paver size as required for best resistance to vehicular loads.
 - c) Design layouts to avoid or minimize paver cutting.

- d) A sampler paver must be submitted before work is approved to begin.
- c) Installation:
 - 1) Per manufacture specifications.
 - 2) Standard design can be changed only when authorized by the UMBS Committee. Joints should be broom in using round silica sand for compaction. The sand must be broom sweep into the paver’s joints to maintain their position in the hardscape. The pavers and the concrete band will evenly meet with no tolerance greater than an eighth (1/8) of an inch for conformance with ADA.
 - 3) Provide a one (1) inch sand bed.
 - 4) Simulate heavy rain conditions to judge uneven settlement, and re-level pavers as necessary. Inspect pavers again 30 days after acceptance by UM, and make further leveling adjustments if uneven settlement is detected.

32 14 43 Permeable Unit Paving

Design Standards

- 1. The Design Professional shall design the permeable unit paving as follows:
 - a. LEED submittal:
 - 1) Product certificates for Credit MR-5.
 - b. Materials:
 - 1) Standard paver shall be Oldcastle Coastal or approved equal by the UMBS Committee.
 - Colors:
 - a) Cream with shellstone aggregate.
 - b) Cream without aggregate.
 - c) Coral Gables Beige without aggregate.
 - Sizes:
 - a) Standard manufacture’s square or rectangular sizes, no polygonal allowed.
 - Design requirements:
 - a) Color mixing allowed in borders, band or geometrical patterns, random mixing is prohibited.
 - b) Herringbone pattern using Coral Gables Beige pavers without aggregate is preferred where subject to vehicular traffic, paver size as required for best resistance to vehicular loads.
 - c) Design layouts to avoid or minimize paver cutting.
 - d) A sampler paver must be submitted before work is approved to begin.

- c. Installation:
 - 1) Per manufacture specifications.
 - 2) Standard design can be changed only when authorized by the UMBS Committee. Joints should be broom in using granite chips for compaction. The granite chips must be broom sweep into the paver's joints to maintain their position in the hardscape. The pavers and the concrete band will evenly meet with no tolerance greater than an eighth (1/8) of an inch for conformance with ADA.

32 17 13 Parking Bumpers

Design Standards

The UMBS Committee prefers curb stops in lieu of parking bumpers. Design parking areas considering a 24" vehicular overhang over landscaped parking medians or parking lot edges. This area of overhang shall not contain vegetation, but rather mulch or gravel as approved by the UM project manager.

However, where curbs are not possible:

1. The Design Professional shall specify the parking bumpers as follows:
 - a. LEED Submittal:
 - 1) Product certificate for Credit MR 4.
 - b. Product: Parking bumpers:
 - 1) Concrete wheel stops:
 - a) 4,000 PSI minimum compressive strength.
 - b) 6 inches high by 8 inches wide by 72 inches long.
 - c) Provide chamfered corners, transverse drainage slots on the underside and a minimum of two factory-formed or drilled vertical holes through wheel stop for anchoring to substrate.
 - d) Units as made by Denmark Cast Stone Co., A. & R. Concrete or accepted equivalent.
 - e) Assigned/labeled parking bumpers must be indicated on drawings. Assigned/labeled parking bumpers will include but not limited to "SERVICE", VISITOR", "RESERVED". Coordinate with UM Public safety / Parking Department for additional requirements.
 - c. Installation:
 - 1) One parking bumper per parking stall.
 - 2) Five eighth (5/8) inch round reinforcing bars driven eighteen (18) inches into the ground.

32 17 23 Pavement Markings**Design Standards**

1. The Design Professional shall design the pavement markings as follows:
 - a. LEED submittal:
 - 1) Product certificates for Credit IEQ 4.2.
 - b. Materials:
 - 1) Pavement markings paint:
 - a) Alkyd-resin type as per AASHTO M248
 - b) Alkyd pavement marking paint as per MPI No. 32.
 - c) Latex pavement marking paint as per FS TT-P-1952 or MPI No. 97.
 - 2) Glass beads.
 - c. Installation:
 - 1) Specify color and stripe width.
 - 2) Pavement to age for 60 days before starting pavement markings.
 - 3) Provide a minimum wet film thickness of 0.15 mils.

Product Standards:

1. Flint Trading Company or approved equal by the UMBS Committee.

32 17 29 Manufactured Traffic Calming Devices**Design Standards**

1. The Design Professional shall specify the manufactured traffic calming devices as follows:
 - a. LEED Submittal:
 - 1) Product certificate for Credit MR 4.
 - b. Product: Traffic calming devices:
 - 1) Speed bumps and humps Solid, integrally colored, 96 percent postconsumer or commingled post-consumer and pre-consumer recycled rubber or plastic; UV stabilized. Provide factory-formed or drilled vertical holes for anchoring to substrate.
 - a) Speed bump: 2 inches high by 10 inches wide by 72 inches with tapered, square, or rounded ends.
 - b) Speed hump: Modular assembly 4 inches high by 14 feet in overall width with overall length as dimensioned on drawings; and with tapered, square or rounded ends.

- c. Installation:
 - 1) Galvanized steel spikes as per manufacturer written recommendation for heavy traffic.
 - 2) Bed of adhesive for adhesion to pavement with heavy traffic as per manufacturer written recommendation.

32 31 13 Chain Link Fences and Gates

Design Standards

1. The Design Professional shall design the chain link fences and gates as follows:
 - a. General requirements:
 - 1) Wind loading as per ASCE 7 and the Florida Building Code.
 - 2) Exposure category C.
 - 3) Fence height to match existing.
 - b. Materials:
 - 1) Fabric shall be in one-piece heights measured between top and bottom of outer edge of selvage knuckle or twist. Comply with CLFMI Product Manual and with requirements indicated below:
 - a) Fabric Height shall match existing UM fencing.
 - b) Steel Wire Fabric: Wire with a diameter of 0.148-inch (9-gauge) zinc coated.
 - c) Mesh size: Two (2) inches.
 - d) Selvage: Knuckled edge to be on top, twist on the bottom.
 - e) Fence and gate fabric to be PVC coated class 2b wire (green in color) as per ASTM F668. Thickness of coating 0.025 inch.
 - 2) Posts and rails: Strength requirements shall conform to ASTM F-699, and fence manufacturers written recommendations.
 - a) Pipe shall be straight, true to section, materials and sizes specified.
 - b) Post and rail coatings to comply with the heavy-duty industrial fence requirements in ASTM F668. Zinc coating and PVC coating shall be the same type, thickness and color as indicated for fabric.
 - 3) Fittings and accessories: Coating shall be the same as indicated for fence fabric.
 - 4) Gates:
 - a) Swing gates: Comply with ASTM F900.
 - b) Sliding gates: Comply ASTM F1184
 - c. Installation:
 - 1) The contractor shall examine areas and conditions, with installer present, for compliance with requirements for site clearing, earthwork, pavement work, and other conditions affecting the performance of the work.
 - 2) Installation will not begin before final grading is completed.
 - 3) Installation will not commence until unsatisfactory conditions have been corrected.

- 4) Installation of the chain-link fencing to comply with ASTM F 567.
- 5) Specify diameters and spacing for drilling or hand-excavation of holes for posts. These holes are to be in firm, undisturbed soil.
- 6) Specify post setting.
- 7) Specify concrete fill:
- 8) Specify terminal posts and line posts: Space line posts uniformly at 10 feet on center maximum. Tension Wire: Install according to ASTM F 567.
- 9) Chain-link fabric shall be applied to outside of enclosing framework. In addition, specify that 2 inches be left between finish grade and bottom selvage unless otherwise indicated. A bottom pipe is required.
- 10) Specify gates according to manufacturer's written instructions, level, plumb, and secure for full opening without interference. Attach hardware using tamper-resistant or concealed means. Specify that ground-set items be in concrete for anchorage. Specify hardware for smooth operation and be lubricated where necessary.
- 11) Design gates to operate smoothly, easily, and quietly, free of binding, warp, excessive deflection, distortion, nonalignment, misplacement, disruption, or malfunction, throughout entire operational range.
- 12) Provide a 6" concrete slab for motor operators, sloped and raised above grade sufficiently to prevent storm water ponding.

32 31 19 Decorative Fences and Gates

Design Standards

1. The Design Professional shall design the decorative fences and gates as follows:
 - a. General requirements:
 - 1) Wind loading as per ASCE 7 and the Florida Building Code.
 - 2) Exposure category C.
 - 3) If fencing exists adjacent to proposed fencing or site, proposed fence design, height, and materials to match existing unless otherwise directed by UM Project Manager. If existing fencing is not present, the UM Project Manager to advise on general requirements for design, height, and materials. The Design Professional is responsible for preparing final design and submitting signed and sealed structural drawings prepared by a structural engineer licensed in the state of Florida for approval prior to ordering of materials or installation of fence.
 - 4) New fencing shall intersect with existing fencing via the use of a column or post. No new fencing shall tie directly into existing fencing material.
 - b. Materials:
 - 1) Picket fences: Factory coated aluminum picket fence, materials, finish, color and design similar to of existing UM picket fences.
 - 2) Coral rock rubble wall topped with metal picket: Materials, finish, color and design similar to existing UM coral rock fences.

- 3) Masonry walls:
 - a) Masonry wall with painted stucco finish and natural keystone coping to match existing similar masonry wall fences.
 - b) Masonry wall with natural keystone veneer similar existing masonry wall fences.
- c. Installation:
 - 1) Contractor shall examine areas and conditions, with installer present, for compliance with requirements for site clearing, earthwork, pavement work, and other conditions affecting the performance of the work.
 - 2) Installation will not begin before final grading is completed.
 - 3) Installation will not commence until unsatisfactory conditions have been corrected.
 - 4) Design coral rock rubble wall topped with metal picket to match materials, finish, color and design of existing UM coral rock fences.
 - 5) Design masonry wall with painted stucco finish and natural keystone coping to similar existing masonry wall fences.
 - 6) Design masonry wall with natural keystone veneer to match similar existing masonry wall fences.
 - 7) Specify gates according to manufacturer's written instructions, level, plumb, and secure for full opening without interference. Attach hardware using tamper-resistant or concealed means. Specify that ground-set items be in concrete for anchorage. Specify hardware for smooth operation and be lubricated where necessary.
 - 8) Design gates to operate smoothly, easily, and quietly, free of binding, warp, excessive deflection, distortion, nonalignment, misplacement, disruption, or malfunction, throughout entire operational range.

32 84 00 Planting Irrigation

Design Standards

1. The Design Professional shall design the planting irrigation as follows:
 - a. General requirements:
 - 1) Irrigation shall be provided for all proposed landscape and turf areas, unless otherwise directed by UM Project Manager.
 - 2) Water use for irrigation must comply with the Miami-Dade County and SFWMD regulatory requirements as well as with the University's water use agreement with the SFWMD.
 - 2) All efforts should be made to connect irrigation to existing well water sources on the University campus. If access to an existing well is not feasible, efforts should be made to drill a new well, which must be tested for water salinity and approved by the UMBS Committee.
 - 3) Potable water may only be used for irrigation with prior authorization by the UMBS Committee.

- 4) Reclaimed or reuse water shall be utilized as much as possible for irrigation. If used, follow requirements of Florida Statutes Chapter 62-610, "Reuse of Reclaimed Water and Land Application", including use of purple for pipes, boxes, etc. as well as advisory signs indicating the use of reclaimed water.
 - 5) Drip irrigation shall be utilized as much as possible.
 - 6) The irrigation system shall be regulated by a rain-gauge or a moisture sensor.
 - 7) Irrigation to provide 100% "head-to-head" coverage.
 - 8) Turf areas shall be served by different zones than groundcover and shrub irrigation
 - 9) 'Rotor' type irrigation heads may not be used for groundcover or shrub irrigation.
 - 10) Rain Bird brand components or equal shall be specified for all irrigation systems unless otherwise authorized by the University.
- b. Materials as follows:
- 1) PVC Pipe: ASTM D 1785, PVC 1120 compound, Schedule 40.
 - a) PVC Socket Fittings: ASTM D 2466.
 - b) PVC Threaded Fittings: ASTM D 2464.
 - 2) Corporation Stops: AWWA C800.
 - a) NPS 1-1/4 to NPS 2 Minimum pressure rating 150 psig.
 - b) Body Material: Brass or bronze with ball or ground-key plug.
 - c) End Connections: Matching piping.
 - d) Stem: With wide-tee head.
 - 3) Tapping valves:
 - a) Cast Iron body compatible with drilling machine, 150 psig.
 - 4) Tapping sleeves:
 - a) Ductile iron sleeve compatible with drilling machine.
 - 5) Irrigation water meters:
 - a) Provided by MDWASD.
 - 6) Irrigation water meter boxes and vaults:
 - a) Water meter boxes and covers: Cast Iron.
 - b) Vaults: Precast concrete with galvanized steel hatches.
 - 7) Backflow preventers:
 - a) Reduced Pressure Backflow Preventers.
 - b) Pressure Vacuum Breakers.
 - 8) Bronze Automatic Control Valves: Cast-bronze body, normally closed, diaphragm type with manual-flow adjustment, and operated by 24-V ac solenoid.
 - 9) Plastic Automatic Control Valves: Molded-plastic body, normally closed, diaphragm type with manual-flow adjustment, and operated by 24-V ac solenoid.
 - 10) Sprinklers:
 - a) Plastic Pop-up, Gear-Drive Rotary Sprinklers: ABS body with pressure compensating fixed or adjustable nozzles, also capable of flow adjustment. Pop-up heights from 4 inches to 12 inches.

- b) Plastic, Spray Sprinklers: ABS body with pressure compensating fixed or adjustable nozzles, also capable of flow adjustment. Pop-up heights from 4 inches to 12 inches.
 - c) Plastic, Fixed Spray Sprinklers: ABS body with pressure compensating fixed or adjustable nozzles, also capable of flow adjustment. Sprinkler installed in riser.
- 11) Drip Irrigation:
- a) Emitters: Polyethylene or vinyl with flow control. They can be singled installed or in manifolds.
 - b) Drip tubes.
 - c) Pressure regulators.
 - d) Filter Units.
 - e) Air relief valves.
 - f) Vacuum relief valves.
- 12) Controllers for Automatic Control Valves (Outside installation). 24 volt interior transformer. Adjustable, 24-hour, 14-day clock, with automatic operations to skip operation any day in timer period, to operate every other day, or to operate two or more times daily:
- a) Specify number of stations. Stations can be programmed from approximately 5 to 60 minutes. Included with switch for manual or automatic operation of each station.
 - b) Exterior Control Enclosures: NEMA 250, Type 4, weatherproof, with locking cover and matching keys; included with provision for grounding.
 - c) Body Material: Enameled-steel sheet metal, stainless-steel sheet metal or molded plastic.
 - d) Mounting: Freestanding type for concrete base or surface type for wall installation.
- 13) Controllers for Automatic Control Valves (Inside installation). 24-volt interior transformer. Adjustable, 24-hour, 14-day clock, with automatic operations to skip operation any day in timer period, to operate every other day, or to operate two or more times daily:
- a) Specify number of stations. Stations can be programmed from approximately 5 to 60 minutes. Included with switch for manual or automatic operation of each station.
 - b) Exterior Control Enclosures: NEMA 250, Type 12, dripproof, with locking cover and matching keys; included with provision for grounding.
 - c) Body Material: Enameled-steel sheet metal, stainless-steel sheet metal or molded plastic.
 - d) Mounting: Wall installation.
- 14) Moisture Sensor: Adjustable from one to seven days, to shut off water flow during rain.
- 15) Wiring: As recommended by controller manufacturer.
- c. Installation:
- 1) Piping requirements:
 - a) Refer to DIVISION 31 EARTHWORK for excavating, trenching and backfilling.

- b) Irrigation main piping to be installed with 36-inch cover under pavements and walkways and 24-inch cover under landscaped areas.
- c) Irrigation circuit piping (to automatic valves) to be installed with 24-inch cover under pavements and walkways and 18-inch cover under landscaped areas.
- d) Piping to be installed as close as possible to the location indicated on the drawings.
- e) Warning tape to be installed directly over the piping.
- f) Piping to be installed within sleeves under parking lots, roadway and sidewalks.
- g) Drip tubes to be installed below ground.
- 2) Sprinklers requirements:
 - a) Pop-up sprinklers to be installed flush with proposed grade. Pop-up height will depend on the type of plants being irrigated.
 - b) Fixed sprinklers to be installed in risers. Riser height will depend on the type of plants being irrigated.
 - c) Sprinklers to be installed as close as possible to locations shown in drawings. If location adjustments are necessary a 100% coverage will need to be maintained.
- 3) Emitters shall be installed as shown on plan. Manifold emitters systems to have tubing to each single emitters.
- 4) Drip irrigation pressure regulators, filter units, air relief valves and vacuum valves shall be installed in control valve boxes.
- 5) Automatic control valves are be installed as close as possible to the irrigation main and within control valve boxes.
 - a) Wiring from automatic control valves to controller shall be installed to the side of the irrigation main.
- d. Testing:
 - 1) Test entire irrigation system at 100 psig for one hour without any loss of pressure.
- e. Connection to existing water mains.
 - 1) Refer to DIVISION 22SW PLUMBING.
 - 2) Provide backflow preventers and meters as required by MDWASD.
- f. Standards for storm water retention for irrigation, verify the UMBS Committee requirements.

32 91 00 Planting Topsoil

Design Standards

- 1. The Design Professional shall design planting topsoil as follows:
 - a. General requirements:
 - 1) All planting topsoil shall be tested by a soil testing laboratory prior to installation or amendment. Conduct soils tests as per standard commercial testing requirements to provide recommendations for soil

amendments, organic matter, and fertilizer mix with application rate and frequency for plant species specified.

- b. New planting topsoil:
 - 1) A mixture of sand, as outlined below, and Everglades Peat conforming to ASTM D 5268. Topsoil shall have a pH range of 5.5 to 7, and have a 4 percent organic material minimum composition. Topsoil shall be free of stones 1 inch or larger in any dimension, debris, salt, and any other extraneous materials harmful to plant growth.
- c. Amendment of existing topsoil for planting:
 - 1) All existing planting topsoil must be tested prior to amendment by a soil testing laboratory and shall be amended as recommended by the laboratory and as approved by the UMBS Committee.
 - 2) Acceptable soil amendments include the following:
 - a) Aluminum Sulfate: Commercial grade, unadulterated.
 - b) Sand: Clean, washed, natural or manufactured silica sand, free of salt, debris or other toxic or extraneous materials. "Concrete Sand" or crushed limestone will not be accepted.
 - c) Peat Humus: FS Q-P-166. Finely divided or granular texture, with a pH range of 6 to 7.5, composed of partially decomposed moss peat (other than sphagnum), peat humus, or reed-sedge peat.
 - d) Sawdust or Ground-Bark Humus: Decomposed, nitrogen-treated, of uniform texture, free of chips, stones, sticks, soil, or toxic materials.
 - e) Other Amendments: As recommended by testing agency and approved by the UMBS Committee.
- d. Typical planting topsoil mixes:
 - 1) Planting soil mixtures for trees, palms, and shrubs: 50% Everglades Peat, 50% coarse clean silica sand, by volume. Add amendments as recommended by testing laboratory.
 - 2) Planting topsoil for lawn areas: 25% Everglades Peat, 75% coarse clean silica sand, by volume. Add amendments as recommended by testing laboratory.
 - 3) Above mixtures are subject to adjustment based on testing laboratory's recommendations and as approved by the UMBS Committee.
- d. Typical planting topsoil depths:
 - 1) Turf and grasses: Planting topsoil depth for turf and grasses shall be installed or amended at a minimum depth of 6".
 - 2) Shrubs: Planting topsoil depth for shrubs shall be installed or amended at a minimum depth of 12"-18".
 - 3) Trees: Planting topsoil depth for trees shall be installed or amended at a minimum depth of 24"-36" within a minimum radius of 2.5 times the rootball diameter; the radius shall be enlarged to accommodate adequate root volume in areas with highly compacted soil.
- f. Compacted soil amendment:
 - 1) Compacted soil in all planting areas shall be remediated by tilling the soil to decompact the soil to a depth appropriate to provide suitable soil root volume for the plant material being planted, as outlined in the "Typical planting soil depths" section immediately above.

- g) Tree root soil volume systems:
 - 1) In areas requiring additional soil volume for tree roots under paved areas, the use of a soil volume system is encouraged. Examples of appropriate soil volume systems are “CU-Structural Soil” as manufactured by Amereq, Inc., or approved equal, and the “Silva Cell” system as manufactured by DeepRoot or approved equal.
- e. Fertilizer:
 - 1) Commercial-grade complete balanced fertilizer of neutral character, with 50 percent derived from natural organic sources of nitrogen, phosphorous, and potassium in the following composition, or as otherwise recommended by the testing laboratory and required by the UMBS Committee.
 - 2) The following forms of fertilizer shall be used. Composition shall be as recommended by testing lab and approved by the UMBS Committee.
 - a. Shrubs and ground covers shall receive a granular fertilizer such as Tri-nite or equal.
 - b. Palms shall receive a palm special mix containing magnesium, manganese, chelated iron and other minor elements such as that produced by Grace or Atlantic Fertilizer Companies, Miami, Florida or other approved source.
 - c. B&B Trees shall receive a time-released fertilizer in the form of packets or briquettes such as Agriform or approved equal.
 - d. Sod shall be fertilized with 10-10-10 fertilizer or as otherwise recommended by the soil testing laboratory and approved by the UMBS Committee.

32 92 00 Turf and Grasses

Design Standards

- 1. The Design Professional shall design turf and grasses as follows:
 - a. General requirements:
 - 1) All turf shall be provided as sod. Seeding is not acceptable.
 - 2) Sod shall comply with "Specifications for Turfgrass Sod Materials" in TPI's "Guideline Specifications to Turfgrass Sodding" and be free of pests.
 - 3) Sod shall be sand grown. Muck grown sod will not be accepted, unless authorized by the University in writing prior to installation.
 - b. Testing as follows:
 - 1) Conduct a soils test as per standard commercial testing requirements to provide recommendations for soil amendments, organic matter, and fertilizer mix with application rate and frequency for turf species specified.
 - c. Materials as follows:
 - 1) Sod shall be solid, either as fifteen (15) inch by eighteen (18) inch pieces or a roll.
 - 2) Acceptable species include the following:
 - a) St. Augustine grass, *Stenotaphrum secundatum*, varieties “Floritam”, “Palmetto”, and “Seville”.

- b) Bahia grass, *Paspalum notatum*, varieties “Argentine” and “Pensacola”.
 - c) Bermuda grass for specialty athletic fields. Variety to be approved by UM prior to installation.
 - 3) Bahia grass to be the only turf species used for non-irrigated areas. All species may be used for irrigated areas.
 - 4) Install planting soil and amendments as outlined in Division 32 91 00 of these Building Standards. Soil amendments and fertilizer shall be used as per the recommendations of the soil testing laboratory.
- c. Installation of the works:
 - 1) Lay sod within twenty-four (24) hours of harvesting. Do not lay sod if dormant or if ground is muddy
 - 2) Lay sod to form a solid mass with tightly fitted joints. Butt ends and sides of sod; do not stretch or overlap. Stagger sod to offset joints in adjacent courses.
 - 3) Water sod immediately after installation.
 - 4) Maintenance: The Contractor shall be responsible for all turf maintenance until Final Acceptance. Such maintenance shall include watering, mowing, weeding, pest treatment, replacement of dead material, and all other operations necessary to provide a viable and thriving landscape at the point of Final Acceptance.

32 93 00 Plants

Design Standards

- 1. The Design Professional shall design plants and vegetation as follows:
 - a. General requirements:
 - 1) Plant selection shall strive for use of Florida native or “Florida-Friendly” species as much as possible. The Florida-Friendly plant database can be found at <http://www.floridayards.org>
 - 2) Do not use category I exotic species, and avoid or use judiciously, category II exotic species, as listed within the Florida Exotic Pest Plant Council’s Invasive Plant Species List.
 - 3) Groundcovers or low growing shrubs shall be used wherever possible to reduce landscape maintenance. Examples include sloped areas, replacement of turf grass in inaccessible or highly shaded areas, erosion prone areas, and areas where mulch washes away or is otherwise difficult to maintain, such as parking lot islands.
 - 4) A minimum tree planting area or island shall be ten (10) feet wide by ten (10) feet long.
 - 5) Trees shall be located a minimum of ten (10) feet from any underground utility to remain and a minimum of fifteen (15) feet from any overhead utility to remain unless it can be demonstrated that the mature size of the tree will not interfere with the utility.
 - 6) Landscape overhanging walkways and plazas to be clear overhead = (10) feet min.

- b. Testing as follows:
 - 1) Conduct a soils test as per standard commercial testing requirements to provide recommendations for soil amendments, organic matter, and fertilizer mix with application rate and frequency for plant species specified.
- c. Materials:
 - 1) All plant material to be Florida No. 1 or better as specified within "Florida Grades and Standards for Nursery Plants".
 - 2) Trees with circling or girdling roots will not be permitted.
 - 3) Install planting soil and amendments as outlined in Division 32 91 00 of these Building Standards. Soil amendments and fertilizer shall be used as per the recommendations of the soil testing laboratory.
 - 4) Mulch:
 - a) Mulch shall be organic wood mulch, free from deleterious materials and suitable as a top dressing for planting bed areas.
 - b) Wood mulch shall be used for planting bed areas, as opposed to gravel or other inorganic mulches, as wood mulch inhibits weed germination and growth, holds in soil moisture, moderates soil-temperature fluctuations (reducing plant stress), improves the soil fertility through the decomposition of organic material, and decomposes at a moderate rate (reducing maintenance).
 - b) Mulch shall be installed at a depth of 2"-4" and shall be pulled back a minimum of 3 inches from the trunk of the tree or shrub so that the trunk and root flare are exposed.
 - b) Mulch shall be Florimulch by Forestry Resources, Inc. or approved equal Grade A Melaleuca mulch that is clean, bright, and free of weeds, moss, sticks, and other debris.
 - c) Other mulches such as pine straw or pine bark "Mini Nuggets" are acceptable if Florimulch is unavailable and if authorized by the UMBS Committee prior to installation.
 - d) Cypress and red color mulch will not be accepted.
 - 5) Staking and bracing systems:
 - a) Design professional shall be responsible for providing staking and bracing details specific to tree and palm sizes and types for review and approval prior to installation.
 - b) Braces for palms shall be made of sound, new pressure-preservative-treated softwood, free of knots, holes, cross grain, and other defects, 2 by 4 inches or 4 by 4 inches, and sized appropriately for the size of the palm.
 - b) Tree staking systems shall use a polypropylene material in green, Arbor Tie by Deep Root, or other approved equal protective material where in contact with branches.
 - c) Staking to occur in area of undisturbed soil surrounding tree.
 - d) For narrow planting areas or in areas where staking would be in conflict with access, use "Platipus" brand or equal type below-grade tree staking system. Ensure root ball sizes meet manufacturer's requirement for using such systems.

- e) Staking systems to be removed at one (1) year after Final Acceptance or longer if tree has not established at that point.
- d. Installation of the works:
 - 1) Tree Protection: All existing trees and specimen plants to remain shall be protected during construction activities.
 - a) Tree barricades shall be used to protect specimen plants and trees to remain larger than four (4) inches in diameter.
 - b) Barricades shall be four feet high, minimum, and constructed of 2" x 4" rails with 4" x 4" posts, minimum.
 - c) Barricades shall enclose the specimen plants, trees, or collective tree group's dripline or a fifteen (15) foot by fifteen (15) foot area, whichever is less.
 - d) No stockpiling of debris, trash, or materials shall be permitted within the barrier area.
 - e) No parking of vehicles or vehicular/equipment traffic shall be permitted within the dripline area or within the tree barricade once erected.
 - f) No grade changes shall occur within the barrier area at any time during construction, and grade changes within the dripline area should be minimized to the greatest extent possible.
 - g) If trimming of trees to remain is required, trimming shall be performed by a certified and licensed arborist as certified by the International Society of Arboriculture.
 - h) Penalties shall be charged to the contractor at a rate of \$500 per caliper inch for specimen plants and trees that are damaged due to construction activities.
 - 2) General requirements:
 - a) No landscape planting shall occur prior to a fully functioning irrigation system to support it.
 - 3) Planting of groundcover and shrubs as follows:
 - a) Planting shall be performed by a licensed contractor to the expected standards of care of landscape contractor professionals within the state of Florida.
 - (b) Plants shall be planted such that one (1) inch of the rootball is above finished grade.
 - (c) Mulch all planting areas with a three (3) inch layer of mulch. Do not mulch over rootballs.
 - 4) Planting of trees and palms:
 - a) Planting shall be performed by a licensed contractor to the expected standards of care of landscape contractor professionals within the state of Florida.
 - b) Trees and palms shall be planted such that two (2) inches of the rootball is above finished grade.
 - c) Trees and palms to be planted plumb.
 - d) Mulch all trees and palms with a three (3) inch layer of mulch. Lightly dust mulch over rootballs such that the depth is no more than one (1) inch. Mulch shall be pulled back a minimum of 3 inches from the trunk of the tree so that the trunk and root flare are exposed.

- 5) Maintenance:
 - a) The Contractor shall be responsible for all landscape maintenance until Final Acceptance. Such maintenance shall include watering, trimming, weeding, pest treatment, replacement of dead material, and all other operations necessary to provide a viable and thriving landscape at the point of Final Acceptance.

32 96 00 Transplanting

Design Standards

1. The Design Professional shall design the transplanting procedures as follows:
 - a. General requirements:
 - 1) Each tree proposed for transplanting to be inspected by a certified arborist, as certified by the International Society of Arboriculture, for recommendation of the tree's general health and expected success rate of transplanting. Arborist to prepare report with recommended preparation and relocation procedures and schedule.
 - 2) All transplanting and trimming activities to be performed by or directly overseen by a certified and licensed arborist.
 - 3) Contractor to submit a tree relocation plan and schedule identifying all required activities for the UM Project Manager's review and approval prior to initiation of any transplanting activities. If utilizing roadways or access ways, a maintenance of traffic plan shall be included within the relocation plan.
 - 4) Contractor to have experience with previous tree relocation of similar magnitude as proposed.
 - 5) Contractor responsible for all required permitting and coordination with utilities, FDOT, and City of Coral Gables as required.
 - b. Testing:
 - 1) A tissue test shall be performed on all trees proposed for relocation.
 - 2) A soils test shall be conducted at all proposed relocation points of the site.
 - 3) The testing agency and certified arborist shall be responsible for making recommendations as per soil amendments, fertilizers, and prepared planting soil for each tree as proposed for their specific transplanted location.
 - 4) Contractor to perform percolation tests at all proposed transplanted locations to ensure good drainage for transplanted trees.
 - c. Materials:
 - 1) Soil amendments, fertilizers, and prepared planting soil as per recommendation of soils and tissue tests.
 - d. Installation of the works:
 - 1) All crown and root pruning shall be conducted as per approved transplanting plan and schedule.
 - 2) Transplanting activities other than root and crown trimming will not occur within hurricane season, June 1st through November 30th.

- 3) Trees to be relocated either directly, within the same day of excavation, or held in a temporary nursery in a container, complete wrap, or temporary planting pit. Relocated trees to be moved a maximum of two times. Contractor is fully responsible for maintaining the health of held trees as per recommendation of certified arborist.
- 4) Contractor to warranty relocated trees for a two (2) year period.

32 97 00 Landscape Stone and Gravel

Design Standards

1. The Design Professional shall design the landscape stone and gravel as follows:
 - a. Stone and boulders:
 - 1) Stone and boulders shall be oolitic limestone or cap rock from Miami-Dade County region, similar in appearance, after weathering, to the native rock visible on the site. Obtain the UMBS Committee's approval of samples before obtaining stone.
 - a. Acceptable gravel types (3/4" maximum size) include the following:
 - 1) Crab orchard gravel.
 - 2) 3/4" Georgia grey granite.
 - 3) Other gravel types are acceptable if approved by the UMBS Committee prior to installation.

DIVISION 33 UTILITIES

- 33.1 General Requirements
 - 33.1.1 Submittals
- 33.2 Codes and Standards
 - 33.2.1 Water Supply Wells for Irrigation, Storm Utility Drainage Piping, and Subdrainage.
- 33.3 Design Criteria
 - 33.3.1 Water Supply Wells for Irrigation, Storm Utility Drainage Piping, and Subdrainage.
- 33.4 Specific Utilities Requirements (organized by CSI MasterFormat® 2013 Numbers & Titles)

33.1 General Requirements

This chapter identifies criteria for the utilities design with the purpose of establishing minimum standards, acceptable to UM, to be used as the basis of design for UM Coral Gables campus buildings.

All work shall be designed by a Professional Civil Engineer licensed in the State of Florida.

The Design Professional shall obtain from the UM Project Manager the following information:

1. Site surveys.
2. Underground utilities information.
3. Geotechnical investigation reports.

The Design Professional shall show in the construction documents plans and profiles of all the stormwater systems. Profiles to be drawn at a minimum of 1" = 50' horizontal and 1" = 5' vertical.

The design of the Utilities must be implemented so there is minimum impact on adjacent buildings, paved areas, vegetation or existing waterways and aquifer. The Design Professional shall specify that all excavation be implemented safely and in compliance with the Trench Safety Act, for those excavations deeper than five (5) feet. Interruption to existing working utilities shall be minimized. In those occasions where interruptions are necessary, UM must be notified 48 hours in advance.

1. Prior to any excavation, locate, mark and identify all existing UG utilities, correlate to GIS data.
2. Prior to covering new and/or exposed existing UG utilities, contact UM PM for update of UG utilities location database / GIS.

The design of the utilities, in concert with other building components, shall produce a building that meets the programmed sustainability rating (LEED rating) of the specified project.

UM Coral Gables Campus and UM Buildings Utilities must be designed to comply with the following objectives:

1. Sustainable Design.
2. Solutions with the best value considering a life cycle cost analysis to account for total project cost.
3. Flexibility to allow for major and minor alterations which will occur during the typical building's life span, without causing major disruptions to other areas of the building. The design of the underground systems shall provide enough capacity for future additions or renovations and allow modifications to be made in one area without causing major disruptions in other areas of the site
4. Design and build facilities equipped with the latest advances in technology, thus requiring a comprehensive design for engineering systems that goes beyond the requirements of the immediate building program.

33.1.1 Submittals

The Design Professional must ensure that all submittals and shop drawings are coordinated with other disciplines.

33.2 Codes and Standards

33.2.1 Water Supply Wells for Irrigation, Storm Utility Drainage Piping, and Subdrainage.

The Design Professional shall specify that the Water Supply Wells for irrigation, Storm Utility Drainage Piping, and Subdrainage comply with the requirements of the applicable authorities having jurisdiction and with the in-force edition at the time of the project of the following codes and standards:

1. Trench safety Act - Florida Statutes, Chapter 553, Part VI
2. Occupational Safety and Health Administration (OSHA) - Excavation Safety Standards
3. American Society of Testing and Materials (ASTM) Standards
4. American National Standards Institute (ANSI)
5. Hydraulic Institute (HI)
6. Miami-Dade County Permitting, Environment and Regulatory Affairs
7. City of Coral Gables Department of Public Works (CGDPW)
8. State of Florida Department of Environmental Protection (FDEP)
9. Environmental Protection Agency (EPA) Regulations

33.3 Design Criteria

33.3.1 Water Supply Wells for Irrigation, Storm Utility Drainage Piping, and Subdrainage.

The Design Professional shall specify the utilities covered in this section, which includes Water Supply Wells for Irrigation, Storm Utility Drainage Piping and Subdrainage.

1. Water supply wells for irrigation should include the following:
 - a. Compute required flow and pressure for irrigation requirements
 - b. Well driller qualifications.
 - c. Materials for well casing.
 - d. Pumps; submersible vertical-turbine pumps or centrifugal pumps.

2. Storm utility drainage piping should include the following:
 - a. Design stormwater system to comply with authorities having jurisdiction.
 - b. Piping materials, depth and location.
 - c. Precast concrete catch basins and manholes. Specify location and depth. Coordinate with water and sanitary sewer lines or other utilities.
 - d. Trench drains and their connections to the stormwater system.
 - e. Coordinate stormwater piping location and depth with water and sanitary sewer lines or other utilities.
 - f. Ensure that the rainwater leaders from the building are routed to catch basins. If they need to be routed to a manhole, then the manhole needs to be provided with a grate and not with a solid cover.

3. Subdrainage should include the following:
 - a. Drawings location of subdrainage.
 - b. Details of subdrainage.
 - c. Geotextile fabric and drainage course.
 - d. Locate connection points to stormwater system.

33.4 Specific requirements (organized by CSI MasterFormat® 2013 Numbers & Titles)

33 21 00	Water Supply Wells for Irrigation
33 41 00	Storm Utility Drainage Piping
33 46 00	Subdrainage

33 21 00 Water Supply Wells for Irrigation

Design Standards

1. The Design Professional shall design the water supply wells for irrigation as follows:
 - a. Required pressure and flows.
 - b. Electrical components devices and accessories as per NFPA 70.
 - c. Compliance of water supply well with AWWA A100.
 - d. Well casing as follows:
 - (1) Steel Casing: AWWA C200, single ply, steel pipe with threaded ends and threaded couplings for threaded joints.

- (2) PVC Casing: ASTM F 480 PVC, Schedule 40 bell-and-spigot pipe and couplings for solvent-cemented joints.
- e. Well seals: Casing cap, with holes for piping and cables, which fits into top of casing and is removable, waterproof, and vermin proof.
- f. Well screens.
- g. Pumps and their appurtenances including all electrical equipment.
- h. Well location and installation.
- i. Well driller is licensed in the State of Florida.
- j. Well installation comply with all applicable regulations.

33 41 00 Storm Utility Drainage Piping

Design Standards

1. The Design Professional shall specify the storm utility drainage piping as follows:
 - a. Piping materials:
 - (1) PVC Corrugated Sewer Piping:
 - (a) Pipe: ASTM F 949, PVC, corrugated pipe with bell-and-spigot ends for gasketed joints.
 - (b) Fittings: ASTM F 949, PVC molded or fabricated, socket type.
 - (c) Gaskets: ASTM F 477, elastomeric seals.
 - b. Drainage structures:
 - (1) Concrete catch basins and curb inlets:
 - (a) As per ASTM C478, for precast, reinforced concrete, of depth indicated, with provision for sealant joints.
 - (b) As per ASTM C913, for heavy traffic precast, reinforced concrete, of depth indicated, with provision for sealant joints.
 - (c) As per ASTM C890, for cast in place, reinforced concrete, of depth indicated, with provision for sealant joints.
 - (d) Size, wall thickness, top slab, base section (sized to prevent floatation). Comply with CGDPW specifications.
 - (e) Steps if depth is more than five (5) feet.
 - (f) Resilient pipe connectors as per ASTM C923.
 - (g) Joint sealant as per ASTM C990.
 - (h) Frame and grate as per ASTM A536 and CGDPW specifications. Grate to be sized according to its tributary area.
 - (i) Adjusting rings.
 - (2) Concrete manholes:
 - (a) As per ASTM C478, for precast, reinforced concrete, of depth indicated, with provision for sealant joints.
 - (b) As per ASTM C913, for heavy traffic precast, reinforced concrete, of depth indicated, with provision for sealant joints.
 - (c) As per ASTM C890, for cast in place, reinforced concrete, of depth indicated, with provision for sealant joints.
 - (d) Size, wall thickness, top slab, base section (sized to prevent floatation). Comply with CGDPW specifications.

- (e) Steps if depth is more than five (5) feet.
 - (f) Resilient pipe connectors as per ASTM C923.
 - (g) Joint sealant as per ASTM C990.
 - (h) Frame and cover.
 - (i) Adjusting rings.
- (3) Concrete control structures:
 - (a) As per ASTM C890, for cast in place, reinforced concrete, of depth indicated, with provision for sealant joints.
 - (b) Size, wall thickness, top slab, base section (sized to prevent floatation). Comply with CGDPW specifications.
 - (c) Steps if depth is more than five (5) feet.
 - (d) Resilient pipe connectors as per ASTM C923.
 - (e) Joint sealant as per ASTM C990.
 - (f) Frames and covers.
 - (g) Adjusting rings.
 - (4) Sloped invert polymer concrete channel drainage systems:
 - (a) Include interlocking-joint precast channel sections, medium or heavy-duty grates, covers and locking mechanism.
 - (5) Wide-width and narrow-width level invert polymer concrete channel drainage systems:
 - (a) Include interlocking-joint precast channel sections, medium or heavy-duty grates, covers and locking mechanism.
 - (6) Steel and stainless-steel, wide-width and narrow-width channel drainage systems:
 - (a) Include trench sections, grates, and vandal proof fasteners.
 - (7) Plastic channel drainage systems:
 - (a) Include interlocking-joint precast channel sections, medium or heavy-duty grates, covers and locking mechanism.
- c. Concrete:
- (1) Cast in place concrete shall be as per ACI 318 and ACI 350R.
 - (2) Concrete strength 4,000 PSI.
 - (3) Maximum water cement ratio of 0.45.
 - (4) Reinforcing fabric shall be as per ASTM A185 steel.
 - (5) Reinforcing bars shall be as per ASTM 615, Grade 60 deformed steel.
- d. Installation:
- (1) The installer shall have a minimum of three years experience in the field and a minimum of five projects completed with similar scope. The installer shall be licensed in the State of Florida.
 - (2) Contractor to examine field conditions prior to proceeding with the work.
 - (3) Contractor to submit shop drawings and product information as required.

33 46 00 Subdrainage**Design Standards**

1. The Design Professional shall specify the subdrainage for retaining walls as follows:
 - a. Piping materials:
 - (1) Perforated PE Pipe and Fittings: ASTM F405 or AASHTO M252, Type CP, corrugated, for coupled joints. Specify size.
 - b. Waterproofing felt:
 - (1) Comply with ASTM D226, Type I, asphalt or ASTM D227, coal-tar-saturated organic felt.
 - c. Geotextile filter fabrics:
 - (1) Description: Fabric of PP or polyester fibers or combination of both, with flow rate range from 110 to 330 gpm/sq. ft when tested according to ASTM D4491.
 - (2) Structure Type: Nonwoven, needle-punched continuous filament.
 - (a) Survivability: AASHTO M 288 Class 2.
 - (b) Styles: Sock or flat style.
 - d. Installation as required.
 - e. Connections with stormwater system:
 - (1) Connect low elevations of subdrainage system to storm drainage system.
 - f. Test and inspections:
 - (1) After installing drainage course to top of piping, test drain piping with water to ensure free flow before backfilling.
 - (2) Remove obstructions, replace damaged components, and repeat test until results are satisfactory.
 - (3) Drain piping will be considered defective if it does not pass tests and inspections.